

INSTRUCTION MANUAL

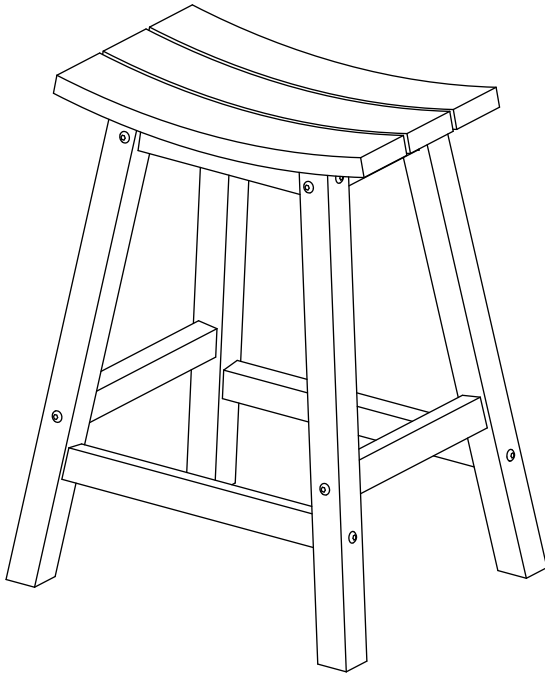

Laguna Contempo 24" Saddle Bar Stool
SKU: OP7002-24

V2.0

! NOTICE

Do not overtighten screws. (Insert all screws before tighten screws.)

- Please do not exceed the weight limitations of this item.
- Do not stand on or use any part of this item as a step ladder.
- Firmly secure all bolts, screws and nuts before use.
- Reconfirm that all bolts, screws, and nuts are secure every 90 days.
- Do not use or store this item in the proximity of open flame or flammable/combustible chemicals.
- Be aware that some parts are heavy and have sharp edges.

TOOLS REQUIRED

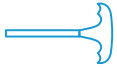

ALLEN WRENCH
(PROVIDED)



STOOL
330 LBS
CAPACITY



1 PERSON
ASSEMBLY



UP TO 20 MIN.
ASSEMBLY

HARDWARE

1

M6.3 x 70mm
BOLT



16 PCS

2

ALLEN
WRENCH



1 PC

PARTS

A

SADDLE

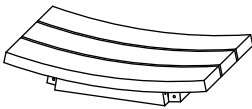

1 PC

B

STOOL LEG

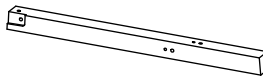

2 PCS

C

STOOL LEG

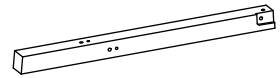

2 PCS

D

SHORT RAIL



2 PCS

E

LONG RAIL



2 PCS

PRODUCT ASSEMBLY

1

Attach part D Short Rail to part C and part B Stool Legs with 2 PCS of Hardware 1 Bolt.

Make sure the steps on the top of the legs are facing each other.

Remove the cap from the safety pin before you fix the Short Rail to Stool legs.

Do not tighten screws too much at this stage.

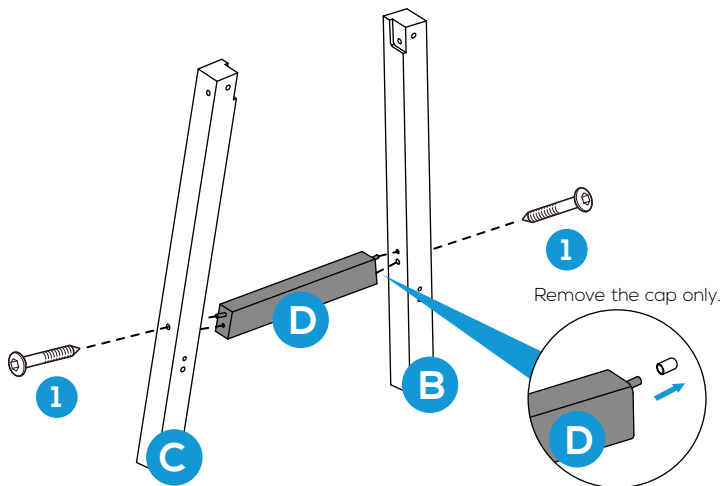

2

Do the same to another Short Rail and the other two Legs.

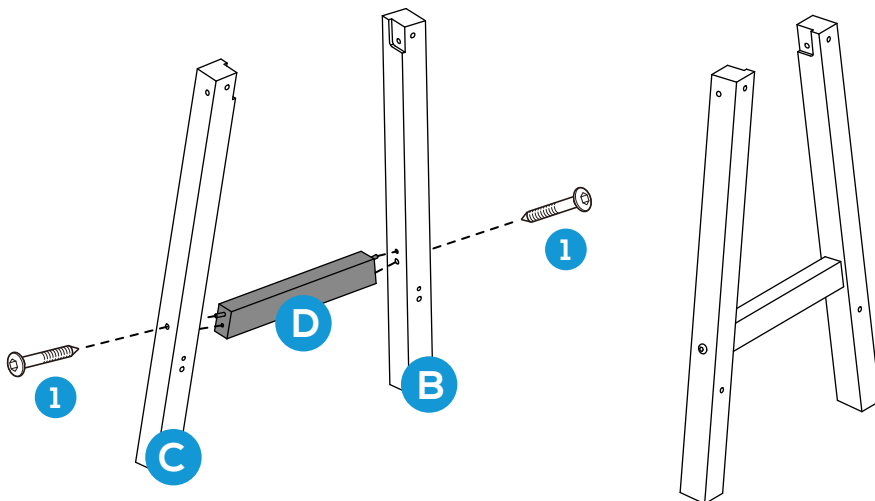

PRODUCT ASSEMBLY

3

Attach part E Long Rail to the combined legs (part C+D+B) as below with 4 PCS of Hardware 1 Bolts.
Remove the cap from the safety pin before you fix the Long Rail to Stool legs.

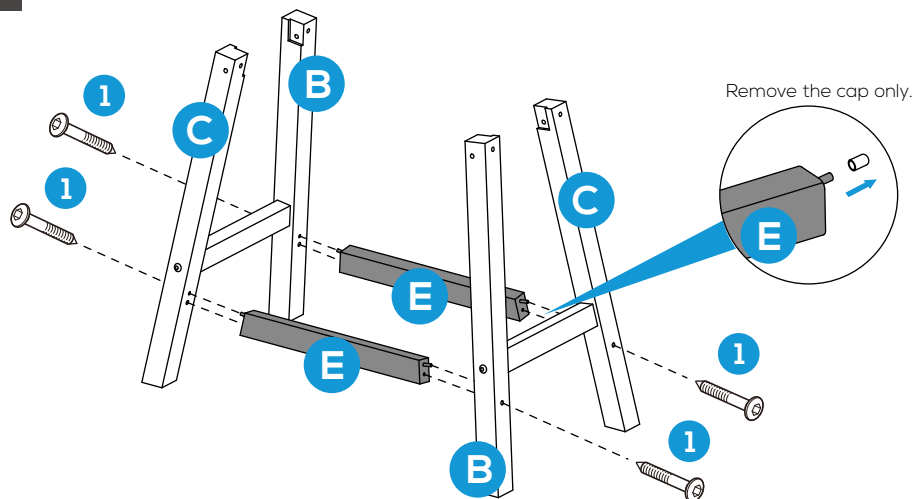

4

Attach part A the Saddle on to the assembled legs and fix them with 8 PCS of Hardware 1 Bolt.
Tighten all the bolts to secure the steady of this stool.

