

INSTRUCTION MANUAL

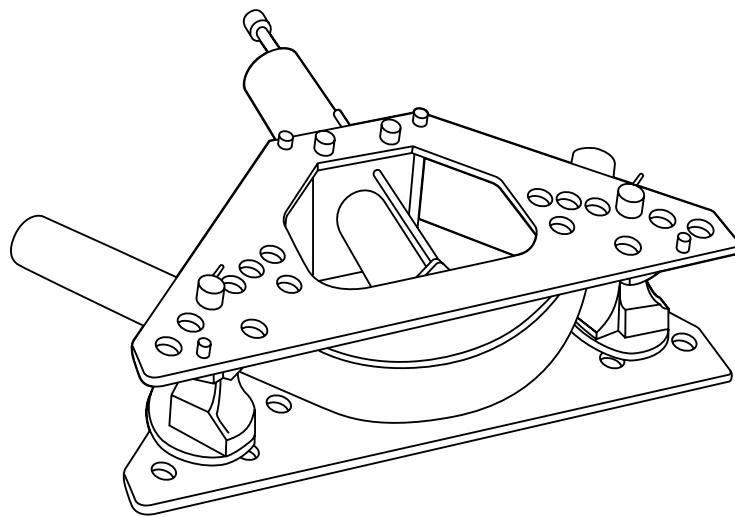

777 SEGMENT BENDER



Read and understand all of the instructions and safety information in this manual before operating or servicing this tool.

Table of Contents

Safe Operating Practices 3

Description and Purpose..... 3

Operating Instructions

 Set-up..... 4

 Bending Conduit..... 5

Bending Instructions

 Glossary of Bending Terms (with illustrations)..... 6

 Laying Out One-Shot 90° Bends..... 7

 Laying Out Offset Bends 8

 Calculating the Center-to-Center Distance 8

 Calculating Shrink..... 9

 Laying Out a Segment Bend 10-12

 Other Bending Information 13

Maintenance

 Exploded View and Parts List..... 14

 Frame Unit – Parts List 15

 Ram – Parts List 16-17

**SAFETY
ALERT
SYMBOL**

The symbol above is used to call your attention to hazards or unsafe practices which could result in an injury or property damage. The signal word, defined here, indicates the severity of the hazard. The message after the signal word provides information for preventing or avoiding the hazard.

⚠ DANGER

Immediate hazards which, if not avoided, **WILL** result in severe injury or death.

⚠ WARNING

Hazards which, if not avoided, **COULD** result in severe injury or death.

⚠ CAUTION

Hazards or unsafe practices which, if not avoided, **MAY** result in injury or property damage.

IMPORTANT SAFETY INSTRUCTIONS

	<p style="text-align: center;">⚠ WARNING</p> <p>Pinch points. Keep hands away from bending shoe, pipe supports, and conduit when bender is in use.</p>
---	---

	<p style="text-align: center;">⚠ WARNING</p> <p>Wear eye protection when operating the bender.</p>
---	---

<p style="font-size: 1.2em;">⚠ WARNING</p>
<ul style="list-style-type: none"> • Make sure all hose fittings are properly seated before starting a bend. Incomplete connections may not allow the ram to retract. It is very difficult to tighten a hose fitting while under pressure. • Do not stand in direct line with the hydraulic ram. <p>Failure to observe these warnings can result in severe personal injury or death.</p>

<p style="font-size: 1.2em;">⚠ CAUTION</p>
<ul style="list-style-type: none"> • Inspect the bender, pump, and hose before each use. Replace damaged, worn or missing parts with Greenlee replacement parts. • Some of the bender parts and accessories are heavy and may require more than one person to lift and assemble. • Conduit moves rapidly as it is bent. The path of the conduit must be clear of obstructions. Be sure clearance is adequate before starting the bend. • Do not operate while wearing loose clothing. <p>Failure to observe these precautions can result in injury or property damage.</p>

Description

The 777 Conduit Bender is intended to bend rigid conduit and Schedule 40 pipe when used with standard bending shoes. It is intended to bend Schedule 80 pipe through XX pipe when used with ductile iron bending shoes.

The bender can accomplish a 90° bend in one shot when using 1-1/2" - 2" shoes. Segment bending is required when using 2-1/2" - 4" shoes.

The bender is to be coupled to any Greenlee hydraulic pump capable of developing 10,000 psi. Suggested pumps are models 755, 975, 976-22PS, 980, and 960 SAPS.

Purpose

This instruction manual is intended to familiarize operators and maintenance personnel with the safe operation and maintenance procedures for the 777 Segment Bender.

KEEP THIS MANUAL

Operating Instructions

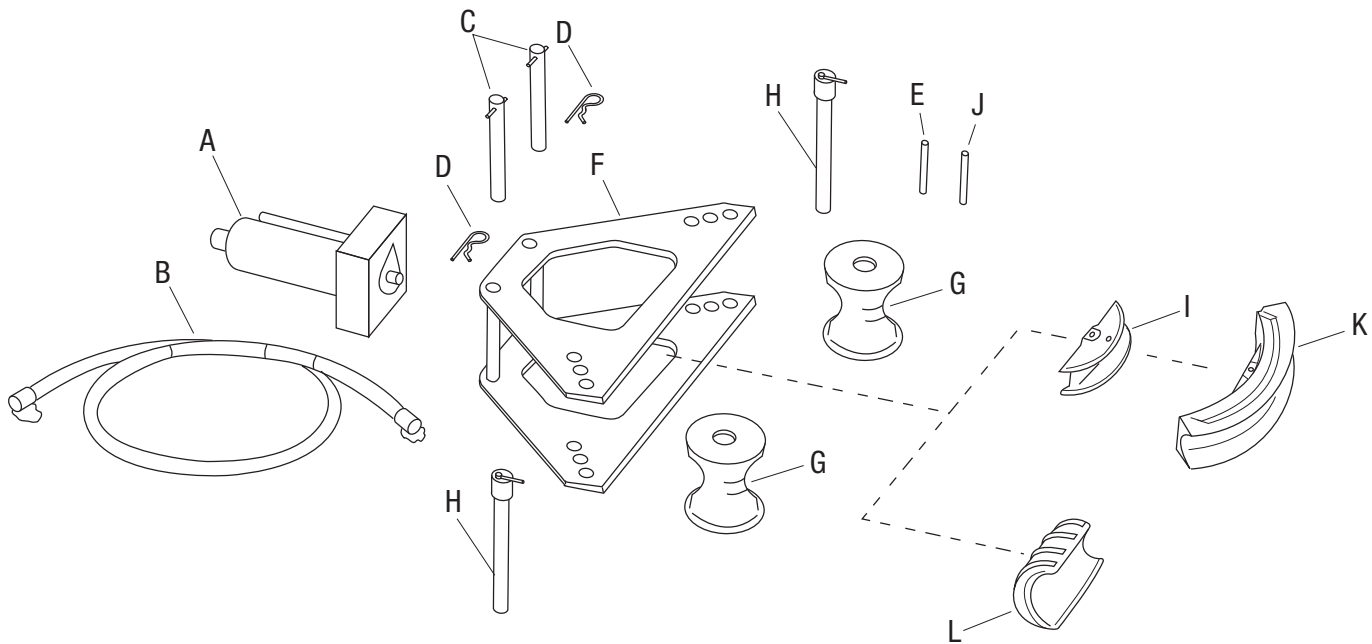

Set-Up

1. Place the ram (A) between the two halves of the frame unit (F).
2. Insert the cylinder head pins (C) through the frame unit (F) and ram (A). Secure the cylinder head pins in place with the spring clips (D).
3. Select the bending shoe (K or L) that corresponds to the size of conduit to be bent.
 - If using a 1-1/2" - 2" shoe (K), attach the shoe to the shoe support (I) with the shoe pin (J). Attach the shoe support to the ram (A) with the ram pin (E).
 - If using a 2-1/2" - 4" shoe (L), attach the shoe to the ram (A) with the shoe pin (J).
4. Place the pipe supports (G) into the frame, locating them in the hole positions that correspond to the size of conduit or pipe to be bent. Orient the pipe support so that the side of the pipe support facing the conduit corresponds to the size of conduit to be bent.
5. Insert the pipe support pins (H) through the upper frame, through the pipe support, and through the lower frame. Secure the pipe supports in place by turning the locking pin over the ball.

6. Connect the high-pressure hydraulic hose (B) to the ram (A) and to the pump (not shown).

Note: Clean the quick-change couplers before making the connections. Hand-tighten the coupling firmly until all of the threads are engaged. Do not use tools.

7. If using an electric pump, plug the electric cord into an appropriate power supply.

WARNING

Make sure all hose fittings are properly seated before starting a bend. Incomplete connections may not allow the ram to retract. It is very difficult to tighten a hose fitting while under pressure.

Failure to observe this warning can result in severe injury or death.

Bending Conduit

- Loosen the ram travel scale nut; set the ram travel scale, which is read at the edge of the block, to zero. Tighten the nut.
 - Mark the conduit. See the instructions for marking the conduit for the necessary bend in this manual.
 - Insert the conduit into the bender. Align the bending mark on the conduit with the center of the bending shoe.
 - Consult the Ram Travel Table to find the amount of ram travel necessary to accomplish the bend.
 - Use the hydraulic pump to advance the ram by the amount of ram travel found in Step 4.
 - Release the hydraulic pressure at the pump and move the conduit to the next bending position.
- Note: If making an offset bend, rotate the conduit 180° before making the second bend. If making a three-bend saddle, rotate the conduit 180° before making the second and third bends. If making a four-bend saddle, rotate the conduit 180° before making the second and fourth bends.*
- Repeat Steps 5 and 6 until the last bend is made.
 - Remove the conduit from the bender.

Ram Travel Table for Common Bends

		Angle of Bend					
		10°	15°	30°	45°	60°	90°
Conduit Size	1/2	1-5/8	1-7/8	2-3/4	3-1/2	4-3/8	5-7/8
	3/4	1-3/8	1-5/8	2-1/2	3-1/4	4	5-1/2
	1	1-1/2	1-7/8	2-13/16	3-3/4	4-1/2	6-1/4
	1-1/4	1-7/8	2-1/4	3-1/4	4-1/4	5-1/4	7
	1-1/2	1-1/4	1-5/8	2-5/8	3-5/8	4-7/16	5-15/16
	2	1-1/4	1-11/16	2-7/8	3-15/16	5	6-5/8

FIGURES ARE APPROXIMATE

Note: To use this table, find the size of the conduit to be bent in the leftmost column and find the desired angle of bend in the top row. The intersection of the appropriate column and row shows the approximate amount of ram travel necessary to accomplish the desired angle of bend.

RAM TRAVEL SCALE

READ SCALE AT EDGE OF BLOCK

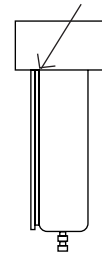

Centerline Bending Radii for the 777 Bender

Rigid Shoe Size (inches)	1-1/4	1-1/2	2	2-1/2	3	3-1/2	4
Bending Radius (inches)	7-1/4	8-1/4	9-1/2	11-7/16	13-3/4	16	18-1/4
Bending Radius (mm)	184.1	209.5	241.3	290.5	349.2	406.4	463.5

Glossary of Bending Terms with Illustrations

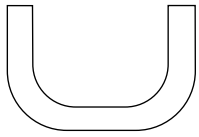

1. **amount of offset** — the distance that the conduit or pipe must be re-routed to avoid an obstruction; see *offset bend* in this glossary and *Offset Bending Instructions* in this manual

2. **back-to-back bend** — any U-shaped bend formed by two parallel 90-degree bends with a straight section of conduit or pipe between the bends

3. **center-to-center distance** — the distance between the successive bends that make up an offset or a three-bend saddle

4. **degrees per shot** — a segment-bending term which refers to the amount of bend accomplished each time the conduit is bent; to achieve a smooth bend, each shot must accomplish the same number of degrees of bend

5. **depth of offset** — same as *amount of offset*

6. **developed length** — the actual length of pipe that will be bent; see distance “C” in the following illustration

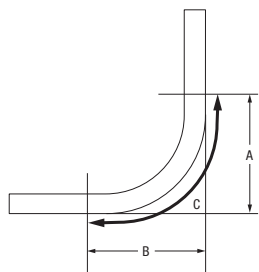

7. **gain** — because conduit and pipe are bent with a radius and not at right angles, the length of conduit or pipe needed for a bend is less than the straight-line measured length; gain is the difference between the right angle distance ($A + B$) and the shorter curved distance (C)

8. **height of offset** — same as *amount of offset*

9. **kick** — single bend of less than 90°

10. **leg length** — the distance from the end of a horizontal section of conduit or pipe to the bend; measured from the end to the outside edge of the conduit or pipe.

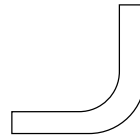
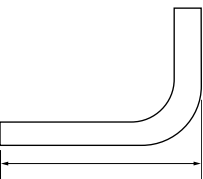

11. **90° bend** — any bend that changes the direction of the conduit or pipe by 90 degrees

12. **number of bending shots** — a segment bending term which refers to the total number of small bends that are required to make up a more gradual segment bend

13. **O.D.** — the size of any piece of conduit or pipe as measured by its outside diameter

14. **offset bend** — two bends with the same degree of bend; used to avoid an obstruction blocking the run of the conduit or pipe

15. **ram travel** — the distance that the ram of hydraulic bender moves to accomplish a particular bend; inches of ram travel are proportionate to degrees of bend

16. **rise** — the distance from the end of a vertical section of conduit or pipe to the bend; measured outside edge of the conduit or pipe.

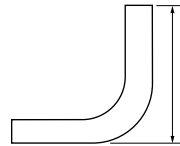

17. **segment bend** — any bend formed by a series of bends of a few degrees each, rather than a single bend; allows a more gradual bend

18. **shot** — a single bend; a shot may accomplish a complete bend or, when making a segment bend, several shots may be required to make a more gradual bend

19. **shrink** — the amount of conduit “lost” when laying out an offset bend working toward an obstruction; see the explanation under *Offset Bending* in this manual

20. **springback** — the amount, measured in degrees, that a conduit or pipe tends to straighten after being bent

21. **stub** — same as *rise*

22. **stub-up** — same as *rise*

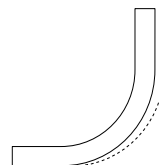

Laying Out One-Shot 90-Degree Bends

1. Measure the length of the required stub. See Figure 1.
2. Find the minimum stub length for that diameter of conduit on the Deduct and Minimum Stub Length Table. The stub you require must be equal to or longer than the minimum stub length.
3. Measure and mark the stub length on the conduit. This is mark 1. Subtract the deduct from the stub and mark the conduit. This is mark 2, or the bending mark. See Figure 2.
4. Insert the conduit into the bender so that mark 2, the bending mark, lies at the center of the shoe.
5. Bend the conduit. To achieve the desired angle, refer to the Ram Travel Table for Common Bends in this manual. See Figure 3.

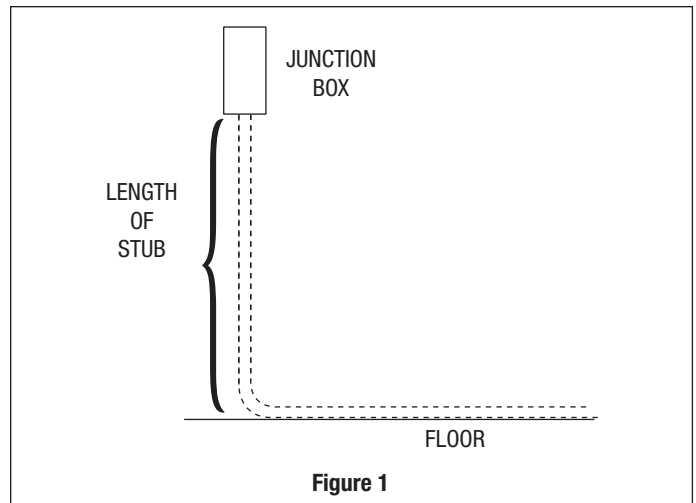
Deduct and Minimum Stub Length Table

CONDUIT SIZE	1/2	3/4	1	1-1/4	1-1/2	2
DEDUCT	1-5/16	1-1/2	1-7/8	2-3/8	2-3/4	3-1/4
MINIMUM STUB LENGTH	12-1/16	12-1/16	14-1/8	15-11/16	15-3/4	17-11/16

FIGURES ARE APPROXIMATE

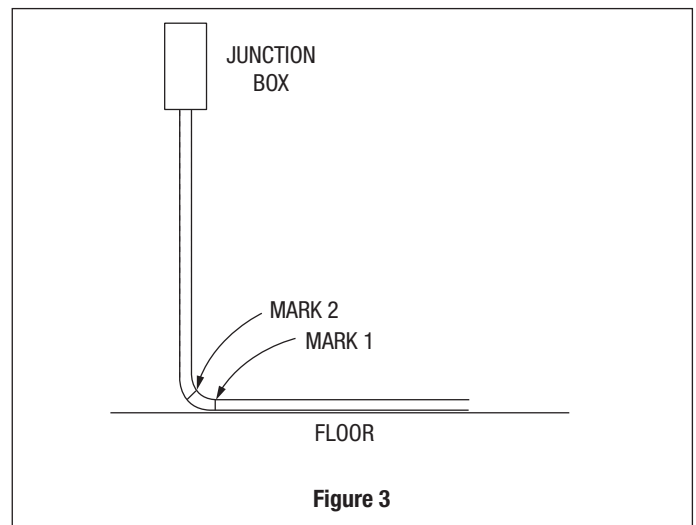
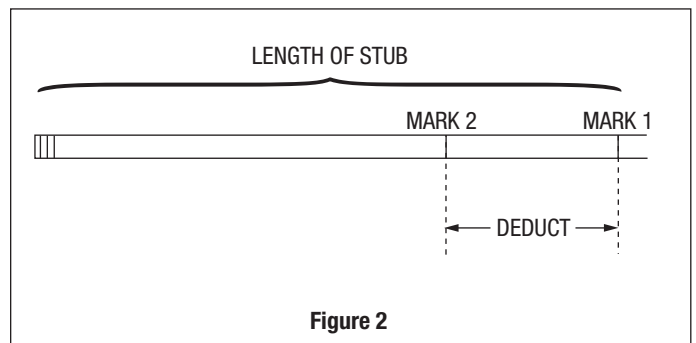

Laying Out Offset Bends

An offset bend is used to route the conduit around an obstruction. To make an offset, two bends are required. The operator must measure the height of the offset and select the angle of the offset. The distance between the two bends is the center-to-center distance.

1. Measure the obstruction.

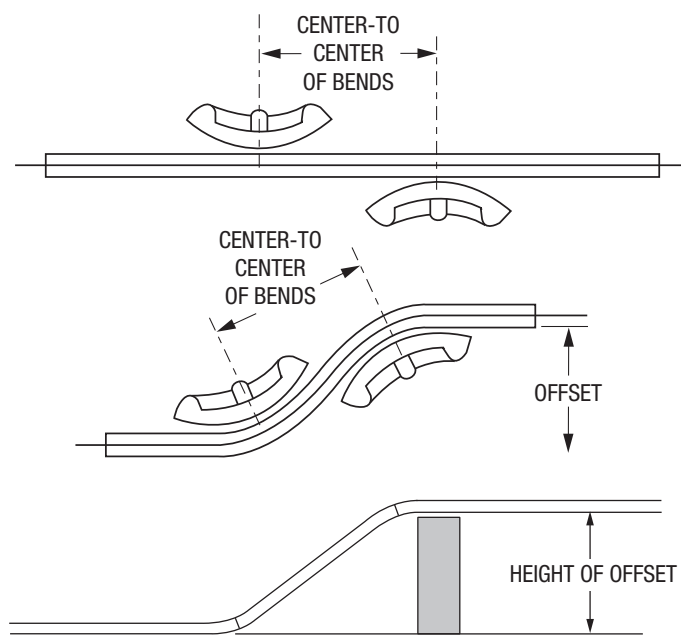

2. Determine the angle of the offset bends.
3. Calculate the center-to-center distance. See the Greenlee Offset Multiplier and Shrink Table.

Note: If working toward an obstruction, calculate the amount of shrink. See Calculating "Shrink" in this manual.

4. Mark the conduit.
5. See bending instructions under "Bending Conduit" in this manual.

Calculating the Center-to-Center Distance

To calculate the center-to-center distance of commonly used offset bends, multiply the amount of offset by the appropriate offset multiplier:

Offset Multipliers

15°	3.86
22-1/2°	2.6
30°	2
45°	1.4
60°	1.2

To use this table: Measure the obstruction and determine the angle of the offset. Find the angle of the offset in the left column; multiply the height of the obstruction by the corresponding multiplier in the right column to find the center-to-center distance.

*Example: 5 inches of offset
15-degree bend*

Multiplier for 15°: 3.86

Multiply the amount of offset by the multiplier to find the center-to-center distance:

$$5 \times 3.86 = 19.3$$

Round off to the nearest common fraction:

$$19\text{-}5/16$$

The following Offset Table shows the center-to-center distance for selected amounts of offset for commonly used bends.

Offset Table

OFFSET ↓		2	4	6	8	10	12	14	16	18	20	22	
		15°	MAX CONDUIT SIZE	3/4	1-1/2	2							
CENTER TO CENTER	7-3/4		15-7/16	23-3/16	30-15/16	38-5/8	46-3/8	54-1/16	61-13/16	69-9/16	77-1/4	85	
30°	MAX CONDUIT SIZE		3/4	1	1-1/2	2							
	CENTER TO CENTER		8	12	16	20	24	28	32	36	40	44	
45°	MAX CONDUIT SIZE			1/2	1	1-1/4	1-1/2	2					
	CENTER TO CENTER			8-1/2	11-15/16	14-1/8	16-15/16	19-13/16	22-5/8	25-7/16	28-1/4	31-1/8	

Laying Out Offset Bends Calculating "Shrink"

When making offsets, it is common practice to make the offset as close to the obstruction as possible. When laying out an offset and working away from an obstruction, no special provisions are required. However, when approaching an obstruction, the conduit "shrinks."

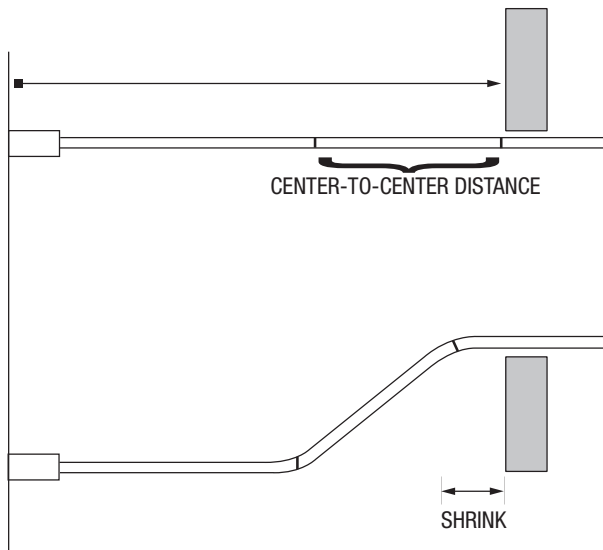

To get the second bend closer to the obstruction, both bends must be adjusted forward. The amount of this adjustment is referred to as *shrink*. The following illustration shows the same installation with shrink factored in.

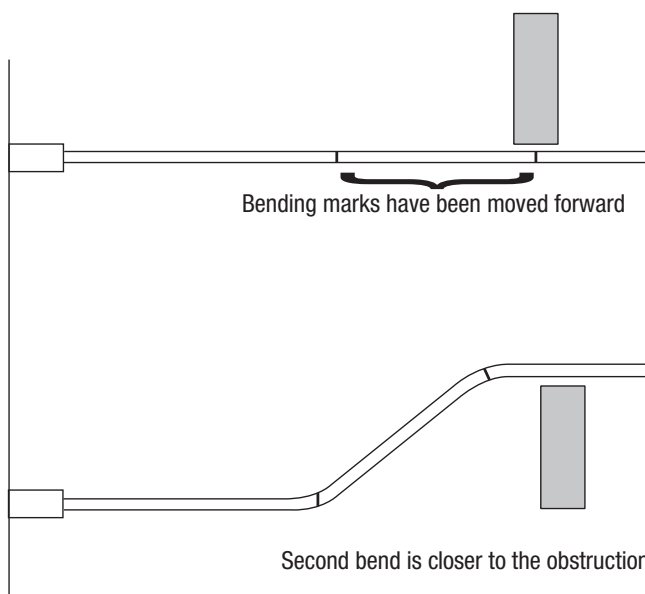

To find the center-to-center distance and the amount of shrink per inch of depth for a particular offset, consult the Greenlee Offset Multiplier and Shrink Table.

Greenlee Offset Multiplier and Shrink Table

OFFSET ANGLE	MULTIPLIER	SHRINK PER INCH OF OFFSET DEPTH
10°	6.0	1/16"
15°	3.86	1/8"
22-1/2°	2.6	3/16"
30°	2.0	1/4"
45°	1.4	3/8"
60°	1.2	1/2"

To use this table: Determine the depth of the offset and the degree of bend. Calculate the center-to-center distance by multiplying the amount of the offset by the multiplier (center column). Calculate the amount of shrink by multiplying the shrink per inch of offset depth (right-most column) by the offset depth.

Example: 6-inch offset
30-degree bend

Multiplier for 30°: 2

Multiply the amount of offset by the multiplier to find the center-to-center distance: $2 \times 6 = 12$

Find the amount of shrink per inch of offset in the table: 1/4"

Multiply the shrink per inch by the amount of the offset: $6 \times 1/4" = 1.5$ inches

Mark the conduit: Place the second bending mark 1.5 inches past the obstruction; measure back toward the starting point and place the first bending mark 12 inches before the second bending mark.

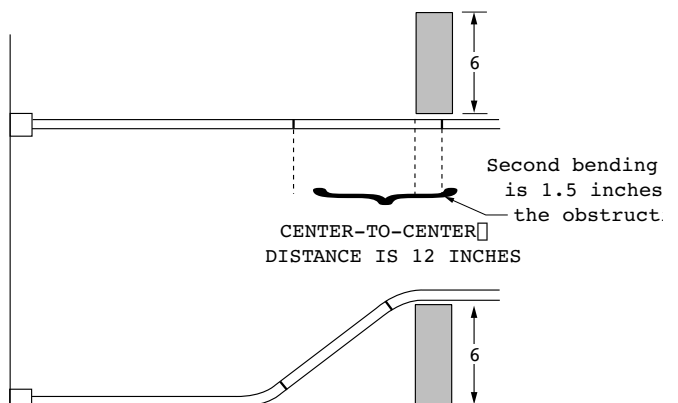

Laying Out a Segment Bend

When a bend with a large radius is necessary, segment bending is required. Segment bending requires a series of small bends, or shots, spaced closely together.

Use the formulas and tables that follow to mark the conduit. To easily and accurately make the bend, use a model 1802 Bending Table or a model 1807 Bending Degree Indicator.

1. Determine the size of conduit to be used, the length of stub needed, the degree of the bend, and the bending radius.

Example: 2" conduit 90° bend
 60" stub 46" radius

2. Find the total length of conduit needed, which is the *developed length*. Use the Developed Length Formula or, for a 90-degree bend, use the Developed Length for 90-Degree Bend Table.

Example: 90° bend, 46"
Formula: $0.01744 \times 90 \times 46 = 72.2$
Table: 72.22

3. Find the location of the center bend and mark the conduit. To find the location, see To Locate the Center of a 90-Degree Bend.

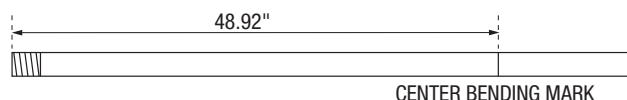

4. Refer to the Suggested Number of Bends Table. Based on the radius, find an appropriate number of bends. This is usually an odd number.

Developed Length: 72.22
Number of Bends: 15

5. Divide the developed length by the number of bends to find the distance between each bend.

Distance Between Bends: $72.22/15 = 4.81$
Round to the Nearest
Fraction or Whole Number: 4-13/16

6. Mark the conduit.

Place marks 4-13/16" apart

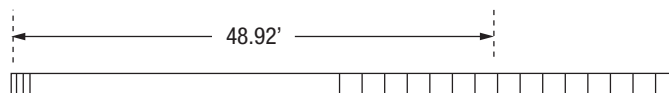

7. Use the Ram Travel Constants Table to find the approximate amount of ram travel per bend.

Ram Travel Constant: 6.2
Number of Bends: 15
Approximate Ram
Travel Per Bend: $6.2 \div 15 = 0.41$ inches

8. Bend the conduit.

Laying Out a Segment Bend (cont'd)
Developed Length

Formula for Any Bend

$$\text{developed length} = 0.01744 \times \text{degree of bend} \times \text{bending radius}$$

Developed Length Table

		RADIUS - Increments by Ones									
		0	1	2	3	4	5	6	7	8	9
RADIUS - Increments by Tens	0	0	1.57	3.14	4.71	6.28	7.85	9.42	10.99	12.56	14.13
	10	15.70	17.27	14.84	20.41	21.98	23.85	25.12	26.69	28.26	29.83
	20	31.40	32.97	34.54	36.11	37.68	39.25	40.82	42.39	43.96	45.53
	30	47.10	48.67	50.24	51.81	53.38	54.95	56.52	58.09	59.66	61.23
	40	62.80	64.37	65.94	67.50	69.03	70.65	72.22	73.79	75.36	76.93
	50	87.50	80.07	81.64	83.21	84.78	86.35	87.92	89.49	91.06	92.63
	60	94.20	95.77	97.34	98.91	100.48	102.05	103.62	105.19	106.76	108.33
	70	109.90	111.47	113.04	114.61	116.18	117.75	119.32	120.89	122.46	124.03
	80	125.60	127.17	128.74	130.31	131.88	133.45	135.02	136.59	138.16	139.73
	90	141.30	142.87	144.44	146.01	147.58	149.15	150.72			

To use this table: Determine the developed length by finding the intersection of the appropriate row ("tens" digit of the radius) and appropriate column ("ones" digit of the radius).

Example: radius is 46 inches

Find the appropriate row: row labeled "40"

Find the appropriate column: column labeled "6"

Find the Developed Length
at that intersection: 72.22

To Locate the Center of a 90° Bend

Measure and mark the length of the stub. Subtract the

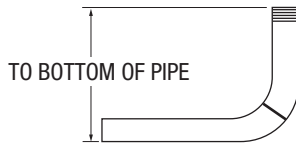

radius of the bend and 1/2 of the O.D. of the pipe. Add 1/2 of the developed length.

Example: 60" stub 46" radius 90° bend

Developed Length: $0.01744 \times 90 \times 46 = 72.2$

1/2 of Developed Length: $72.2 \times 1/2 = 36.1$

Center Mark: $60 - 46 - 1.18 + 36.1 = 48.92$

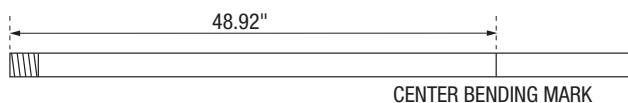

Laying Out a Segment Bend (cont'd)
Suggested Number of Bends Table

Radius	Suggested Number of Bends*	
	(minimum)	(maximum)
4" - 10"	2	3
10" - 20"	3	5
20" - 30"	5	9
30" - 40"	9	13
40" - 50"	13	19
50" - 60"	19	25

*The minimum and maximum number of bends are suggestions only. Using a larger number of bends will produce a smoother segment bend.

Ram Travel Constants Table

Conduit or Pipe Size	1/2"	3/4"	1"	1-1/4"	1-1/2"	2"	2-1/2"	3"	3-1/2"	4"
"D"	5.2	5.2	5.2	5.2	5.2	6.2	7.1	8.1	9.1	10.2

To use this table: Find the conduit or pipe size in the top row, and find the constant "D" that corresponds to that size. Divide constant "D" by the number of bends to be made. The result is the amount of ram travel per bend required AFTER the shoe contacts the conduit or pipe.

Outside Diameter of Galvanized Rigid Conduit or Schedule 40 Pipe

OUTSIDE DIAMETER PIPE AND RIGID CONDUIT		ONE-HALF THE OUTSIDE DIAMETER
SIZE	O.D. FRACTION	O.D. FRACTION
1/2" =	0.840 = 27/32	0.420 = 27/64
3/4" =	1.050 = 1-3/64	0.525 = 17/32
1" =	1.315 = 1-5/16	0.658 = 21/32
1-1/4" =	1.660 = 1-21/32	0.830 = 53/64
1-1/2" =	1.900 = 1-29/32	0.950 = 61/64
2" =	2.375 = 2-3/8	1.187 = 1-3/16
2-1/2" =	2.875 = 2-7/8	1.437 = 1-7/16
3" =	3.500 = 3-1/2	1.750 = 1-3/4
3-1/2" =	4.000 = 4	2.000 = 2
4" =	4.500 = 4-1/2	2.250 = 2-1/4
5" =	5.562 = 5-9/16	2.786 = 2-25/32
6" =	6.625 = 6-5/8	3.312 = 3-5/16

Gain Factor Table

		ANGLE - Increments by Ones									
		—	1°	2°	3°	4°	5°	6°	7°	8°	9°
ANGLE - Increments by Tens	0°	.0000	.0000	.0000	.0000	.0000	.0000	.0001	.0001	.0003	.0003
	10°	.0005	.0006	.0008	.0010	.0013	.0015	.0018	.0022	.0026	.0031
	20°	.0036	.0042	.0048	.0055	.0062	.0071	.0079	.0090	.0100	.0111
	30°	.0126	.0136	.0150	.0165	.0181	.0197	.0215	.0234	.0254	.0276
	40°	.0298	.0322	.0347	.0373	.0400	.0430	.0461	.0493	.0527	.0562
	50°	.0600	.0637	.0679	.0721	.0766	.0812	.0860	.0911	.0963	.1018
	60°	.1075	.1134	.1196	.1260	.1327	.1398	.1469	.1544	.1622	.1703
	70°	.1787	.1874	.1964	.2058	.2156	.2257	.2361	.2470	.2582	.2699
	80°	.2819	.2944	.3074	.3208	.3347	.3491	.3640	.3795	.3955	.4121
	90°	.4292	—	—	—	—	—	—	—	—	

To use this table: Find the gain factor by finding the intersection of the appropriate row (“tens” digit of the angle) and appropriate column (“ones” digit of the angle). See example below.

Example: 64° bend
 15-inch center line radius

Correct row: row labeled “60°”

Correct column column labeled “4°”

Gain Factor: 0.1327

Gain for total bend: 0.1327 x 15 = 1.9905
 round up to nearest whole
 number or common fraction

Gain for total bend: 2"

Additional Pipe Support Locations

The 777 has four unmarked holes in the frame. These permit bends closer to the end of the pipe or conduit. Figure 4 shows the bending of 4" conduit with the pipe supports in the normal position. Use these unmarked holes for bending a few degrees of offset, or kicks, in the conduit.

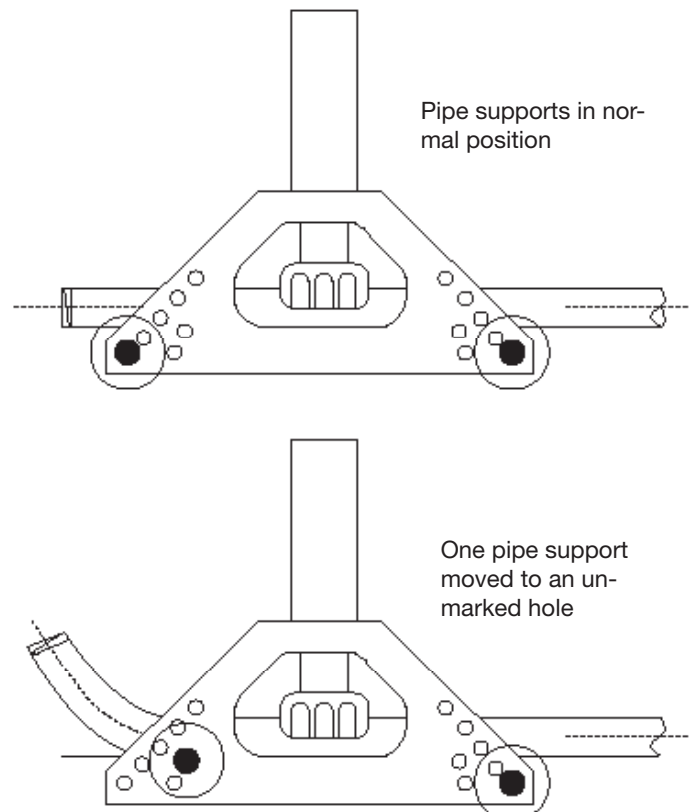
Figure 4

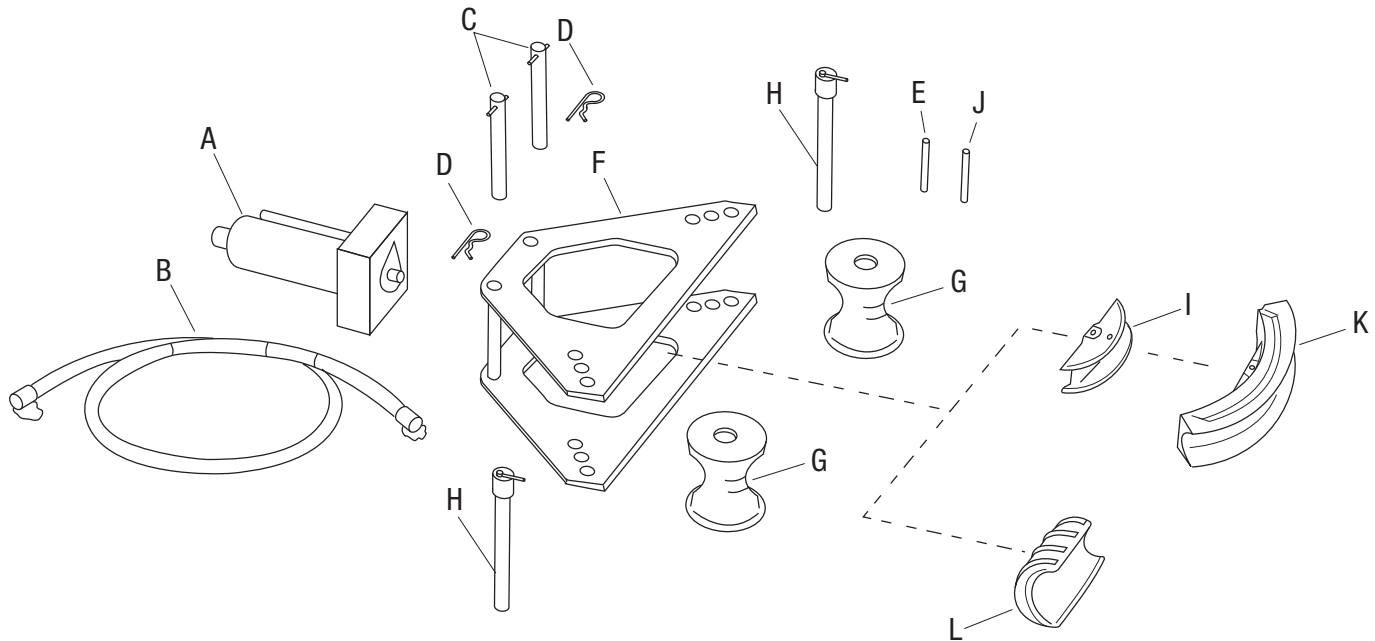
Parts List

Key	Cat No.	Part No.	Description	Qty
A	1736	501 3251.2	27-Ton Ram with 4018GB female quick coupler (includes C)	1
B	1 1289	501 1289.9	3/8" x 6' High Pressure Hose with two 4033GB male quick couplers.....	1
C	1 3252	501 3252.0	Cylinder head pin (includes D).....	2
D	2725AA	905 0302.3	Spring clip	2
E	1 0826	501 0826.3	Ram pin	1
F	1 3232	501 3252.0	Frame unit.....	1
G	1 3193	501 3193.1	Pipe support	2
H	1 4496	501 4496.0	Pipe support pin	2
I	1 0939	501 0939.1	Small shoe support (1/2" thru 2").....	1
J	1 0826	501 0826.3	Shoe pin	1
K			90° Aluminum Bending Shoe	
	1 0920	501 0920.0	1-1/4" Shoe — 7-1/4" centerline radius	
	1 0921	501 0921.9	1-1/2" Shoe — 8-1/4" centerline radius	
	1 0922	501 0922.7	2" Shoe — 9-1/2" centerline radius	
L			Aluminum Segment Bending Shoe	
	1 3208	501 3208.3	2-1/2" Shoe — 11-7/16" centerline radius	
	1 3209	501 3209.1	3" Shoe — 13-3/4" centerline radius	
	1 3210	501 3210.5	3-1/2" Shoe — 16" centerline radius	
	1 3211	501 3211.3	4" Shoe — 18-1/4" centerline radius	
M	1 3382	501 3382.9	Steel Storage Box (not shown)	

⚠ WARNING

Use ductile iron shoes for bending pipe heavier than schedule 40. See Greenlee catalog for details.

777 Frame Unit - Parts List

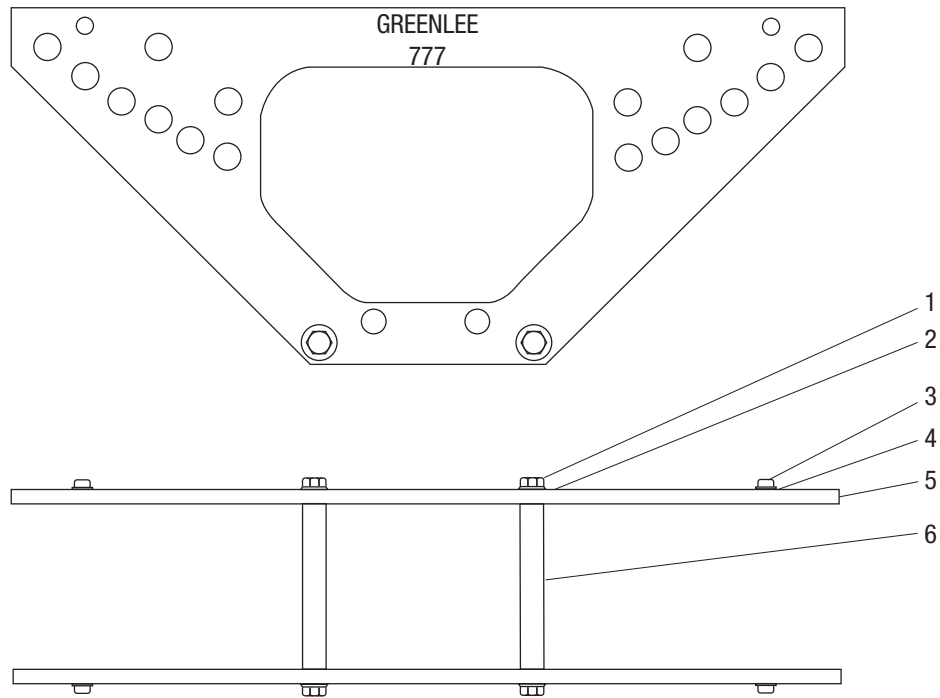

Key	Part No.	Description	Qty
1	905 0543.3	Hex Head Screw, 1/2-13 x 1-1/4.....	4
2	905 1510.2	Flat Washer, 17/32 x 1-1/16 x 3/32 SAE.....	4
3	905 0594.8	Socket Head Cap Screw, 3/8-16 x 1/2.....	4
4	905 0506.9	Lockwasher, 3/8 x .136 x .070.....	4
5	501 3231.8	Cross Frame Plate	2
6	501 3223.7	Frame Support Pin.....	2
	502 2345.3	Decal, Ram Travel.....	1
	502 1339.3	Decal, Offset.....	1

1736 Ram — Exploded View

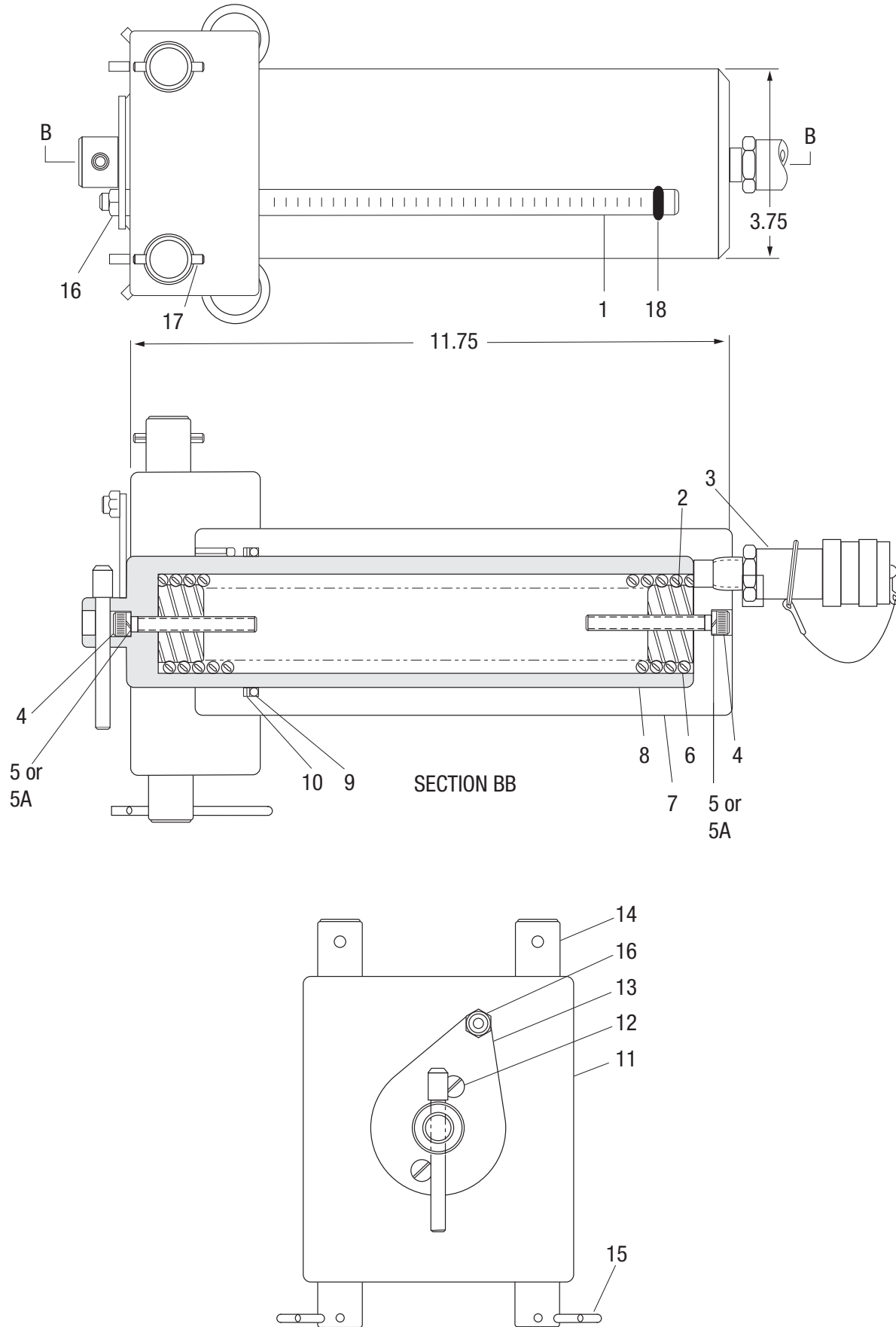

1736 Ram — Parts List

Key	Control No.	Description	Qty
1	500 6221.2	Scale.....	1
2	501 3220.2	Spring Retainer.....	2
3	905 0807.6	Quick Coupler.....	1
4#	500 1717.9	Spring Retainer Screw.....	2
5	501 3496.5	Nylon Washer.....	2
5A*	501 3420.0	Nylon Washer.....	2
6	501 3219.9	Spring.....	1
7	501 3229.6	Cylinder.....	1
8	501 4495.2	Piston.....	1
9	905 0192.6	O-Ring, 2-5/8 x 3 x 3/16.....	1
10	905 0193.4	Back-up Ring, 2-5/8 x 3.....	1
11	501 3228.8	Cylinder Block.....	1
12	905 0850.5	Flat Hd. Screw, 10-32 UNF x 5/16.....	2
13	502 1953.7	Scale Bracket.....	1
14	501 3252.0	Cylinder Head Pin Unit (includes 905 0302.3 and 905 0422.4).....	2
15	905 0302.3	Spring Clip.....	2
16	905 0848.3	Hex, Steel Light Jam Nut, 3/8-24 UNF.....	1
17	905 0422.4	Roll Pin, 7/32 x 1-3/8.....	2
18	905 1384.3	O-Ring, 3/8 x 1/2 x 1/16.....	1
19	501 0826.2	Ram pin.....	1
	501 2121.9	Safety Decal (not shown)	
	501 3799.9	Pkg. Repair Kit (not shown)	

* Use nylon washer (#5) if possible. If c'bore is too small (0.4425/.4375), use alternate washer (5A).

On units prior to August 1996, use Part No. 501 1341.0 (Rear Retainer Screw).



4455 Boeing Drive • Rockford, IL 61109-2988 • USA • 815-397-7070
©2019 Greenlee Tools, Inc. • An ISO 9001 Company

www.greenlee.com

USA Tel: 800-435-0786
Fax: 800-451-2632

Canada Tel: 800-435-0786
Fax: 800-524-2853

International Tel: +1-815-397-7070
Fax: +1-815-397-9247