

# Special Needs Series

## SUBMITTAL DATA

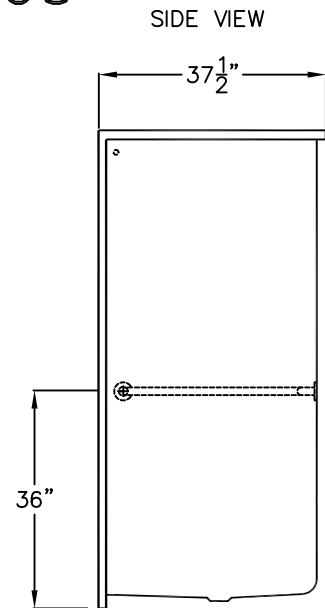
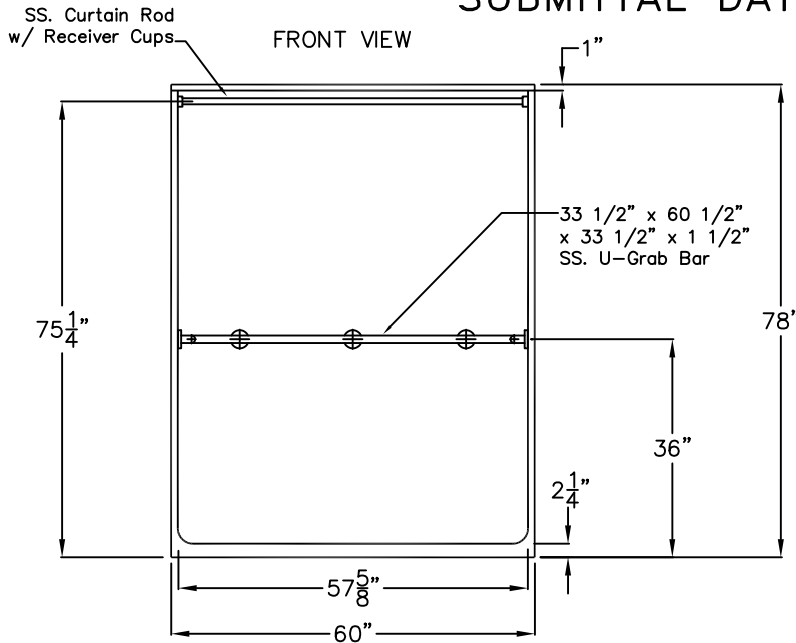

### Roll-In Shower Stall

The shower enclosure shall be Praxis Model HS 763 center, right or left. Finished surface shall be of a sanitary-grade polyester Gelcoat exhibiting a minimal thickness of 15 dry mils, and a finished cured Barcol hardness of 80-90 as tested with ASTM D-2583. Unit construction shall be of molded reinforced fiberglass with a 15% minimum fiberglass content. The unit shall have outside dimensions of 60" x 37 1/2" x 78". The base shall be attached to the sump of the unit in such a manner to form an integral part with an inner and outer coating of reinforced polyester resin. The unit shall meet ANSI 117.1, IAPMO Z124-2011, ADA, HUD, BOCA, Home Innovation Research Lab, UPC, and shall meet the requirements of the Southern Building Code.

The enclosure shall be equipped with the following installed accessories:

- 1) one 33 1/2" x 60 1/2" x 33 1/2" x 1 1/2" diameter, stainless steel U-grab bar, with 1 1/2" statute clearance, mounted with stainless steel bolts and secured from the rear with a 3" x 3" x 11 gauge metal mounting plate, 2) one inch diameter 18 gauge stainless steel curtain rod with receiver cups, 3) 2 1/4" threshold.

**NOTE: ROOM FLOOR MUST BE BUILT UP TO BE EVEN WITH TOP OF SHOWER THRESHOLD FOR A NON RECESS INSTALLATION OF THIS UNIT. (TAS COMPLIANCE. SEE BELOW)**

THIS UNIT FEATURES THE OUTSIDE DIMENSIONS OF 60" OF OVERALL WIDTH. THIS DOES NOT ALLOW FOR FULL ENCLOSURE OF THE BOLTS THAT ARE USED TO SECURE THE BARS AND SEAT IN PLACE. THE BOLT AND NUT COMBINATION SHOULD NOT PROTRUDE MORE THAN 3/4" ON EITHER SIDE.

THIS SHOULD NOT CREATE ANY TYPE OF INSTALLATION PROBLEMS EXCEPT FOR A DRY WALL ENCLOSED FIRE WALL INSTALLATION AREA THAT WOULD NOT ALLOW FOR ANY VARIATIONS. IN A STANDARD STUD OPENING, INSTALLATION OF THE EXTENSION OF THE HARDWARE SHOULD NOT CAUSE ANY TYPE OF PROBLEM.

**NOTE: THIS UNIT WILL NOT ACCEPT A DOOR!**

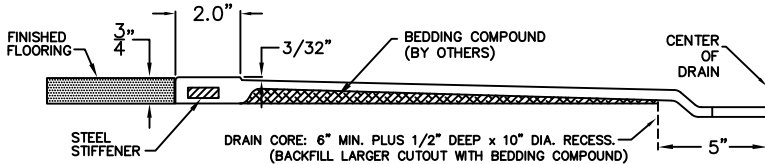

TOP VIEW

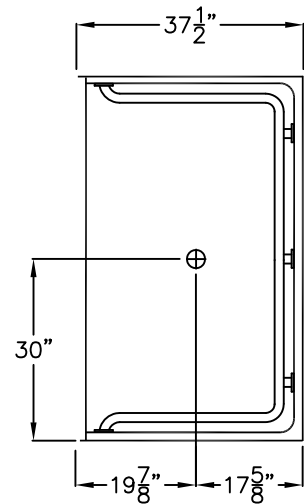

DUE TO THE NATURE OF THE MATERIALS DIMENSIONS MAY VARY ± 1/2"

## PRAXIS

Approved by Print Name

Drawing#: HS763 SUB CR

Approved by Signature:

Date Approved:

Date: 10-8-08

Revised: 6-4-14

Rep.:

Wholesaler:

Quote No.:

PRAXIS INDUSTRIES, LLC.  
435 INDUSTRIAL RD - SAVANNAH, TN 38372  
1 (800) 443-7269 - FAX (731) 925-4290