

# Installation Instructions

## Electronic Wall-Mount Faucet

Record your model number:

Noter le numéro de modèle:

Anote su número de modelo: \_\_\_\_\_

Français, page 19

Español, página 38

**KOHLER**®

# Thank You for Choosing KOHLER

---

Need help? Contact our Customer Care Center.

- USA/Canada: 1-800-4KOHLER (1-800-456-4537) Mexico: 001-800-456-4537
- Service parts: [kohler.com/serviceparts](https://www.kohler.com/serviceparts)
- Care and cleaning: [kohler.com/clean](https://www.kohler.com/clean)
- Patents: [kohlercompany.com/patents](https://www.kohlercompany.com/patents)

## Warranty

---

This product is covered under the **KOHLER® One-Year Limited Warranty**, found at [kohler.com/warranty](https://www.kohler.com/warranty). For a hardcopy of warranty terms, contact the Customer Care Center.

## Tools

---

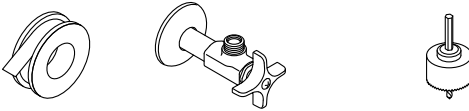
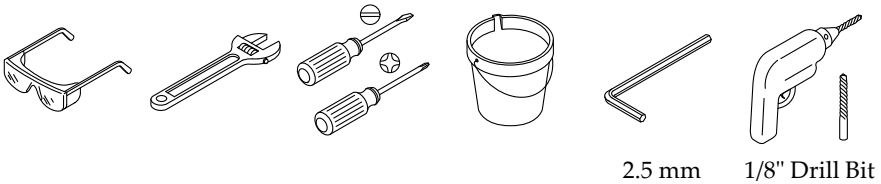

Sealant Tape   3/8" Supply Stop   1-1/4" to 1-1/2" Hole Bit

### Plus:

- Wire Fasteners
- Woodworking Tools
- Pipe Fitting Tools
- Wood Screws
- 2x4s
- PVC Tubing

## Before You Begin

---



**CAUTION: Risk of property damage.** Do not use lithium ion batteries with this product. Exposing lithium ion batteries to water can result in a fire.

Follow all local plumbing and building codes.

Turn OFF the water supplies.

Inspect the supply tubing for damage. Replace as necessary.

Site preparation and wall finishing may require additional tools and materials.

For installation with a mixing valve, two 3/8" compression supply hoses are required.

# 1. Install the Mounting Bracket

---

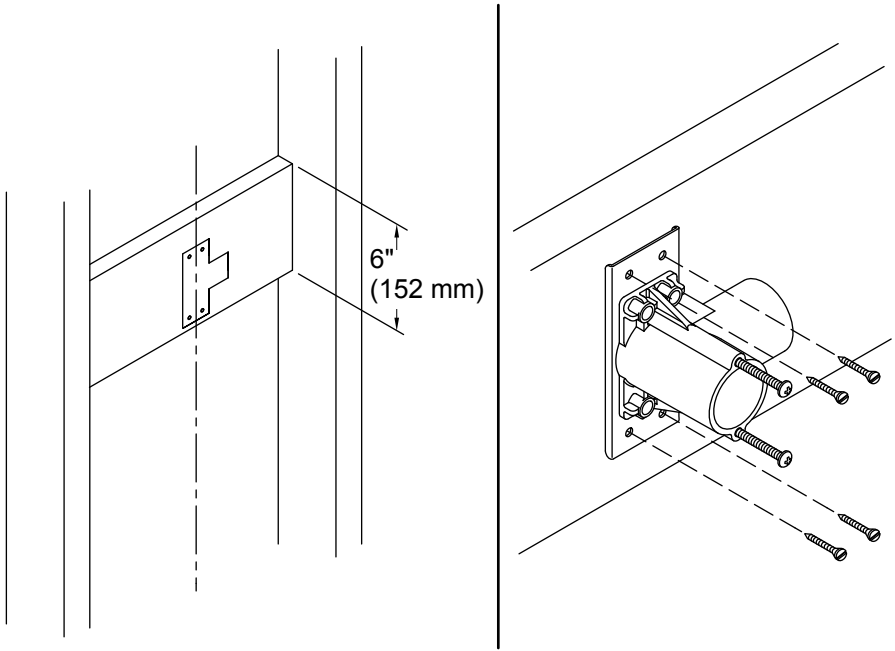

**IMPORTANT!** Verify that the location of the valve is correct before securing the valve in place. The centerline of the drain and faucet should be in line with each other.

**IMPORTANT!** Your faucet model may have different framing requirements other than those shown. Refer to the Specification Sheet for your faucet model.

- Construct the framing for your installation.
- Secure the mounting bracket to the framing using four wood screws.

## 2. Install Tubing (Recommended)

---

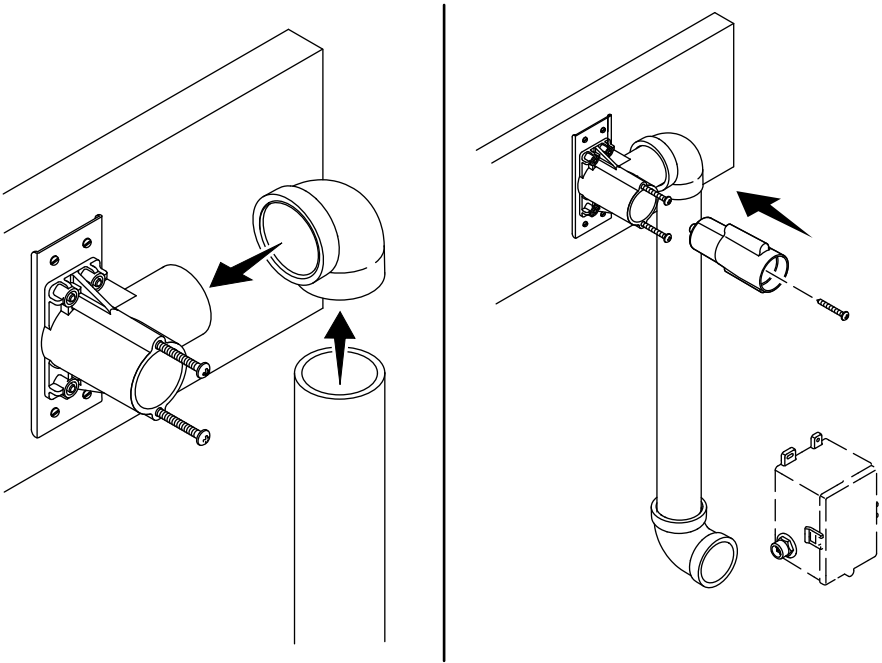

**NOTE:** Tubing (not provided) can be attached to the mounting bracket to route the cables and the spout tube to the control box. PVC fittings (not provided) are recommended.

**NOTE:** Refer to the Specification Sheet to determine the control box installation location.

- Connect a 90-degree elbow and a straight tube to the mounting bracket as shown. Verify that the tube is long enough to reach the control box.
- Connect another elbow to the end of the tube at the control box installation location.
- Install the plaster guard with the screw.

### 3. Route the Cables and Tube

---

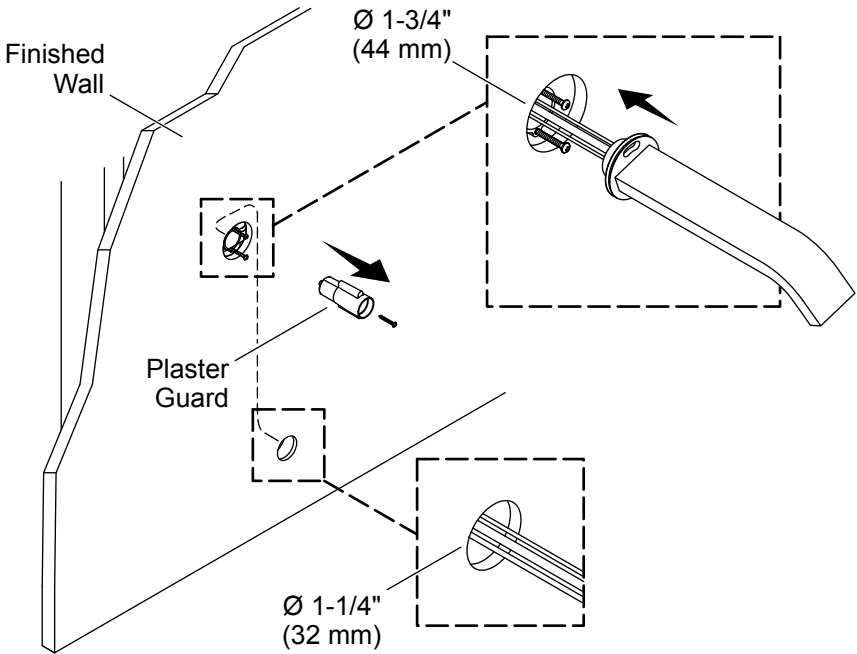

**NOTE:** Refer to the Specification Sheet to determine the control box installation location.

- Finish the wall with a 1-3/4" (44 mm) hole for the spout and a 1-1/4" (32 mm) hole for the sensor cables.
- Remove the plaster guard.
- Guide the sensor cables and tube from the spout through the mounting bracket and down to the hole for the control box.
- Take care to avoid kinking or damaging the cables and tube.

## 4. Install the Spout

---

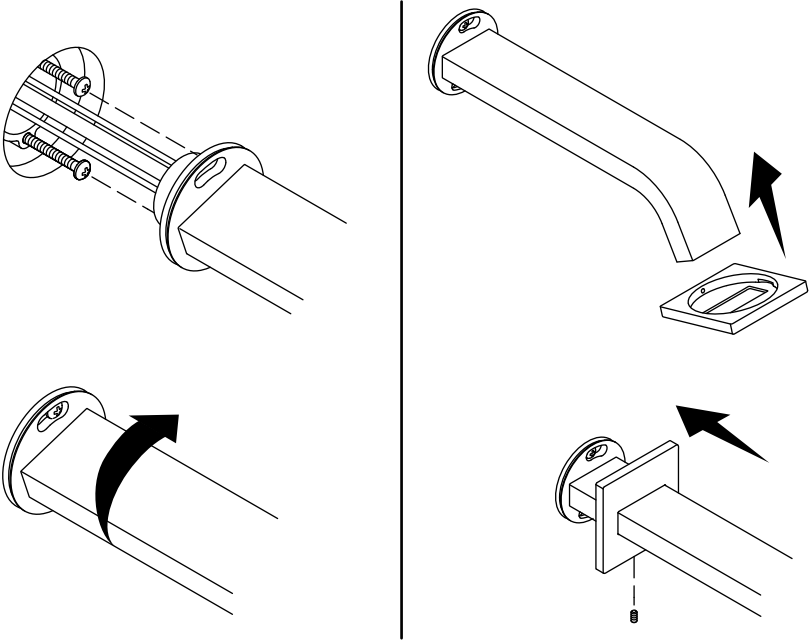

- Position the keyholes on the spout over the screwheads on the mounting bracket. Loosen the screws if needed.
- Align the spout by rotating clockwise.
- Tighten the screws to secure the spout to the mounting bracket.
- Remove the setscrew from the wall plate.
- Slide the wall plate over the spout until flush with the wall. Take care not to damage the finish.
- Secure the wall plate with the setscrew.

## 5. Install the Control Box

---

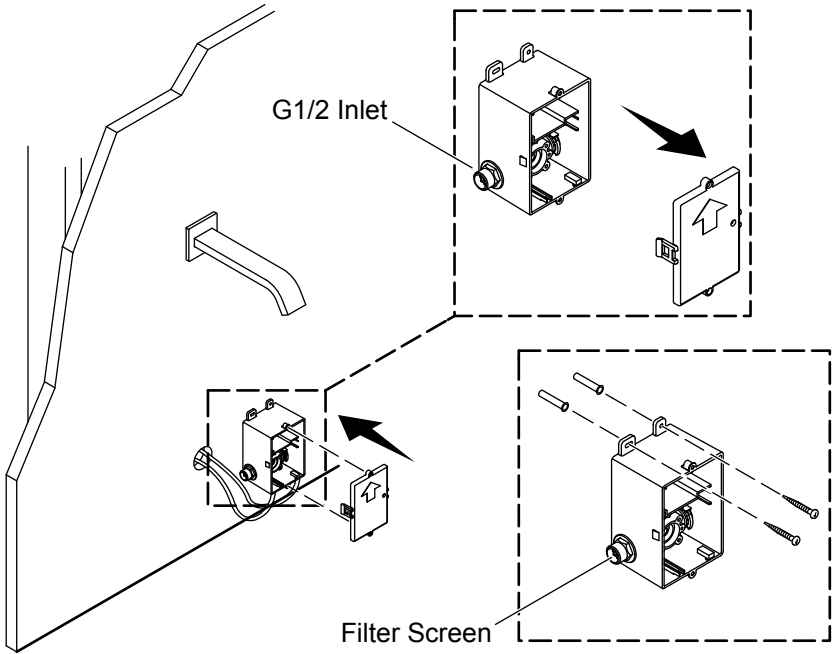

**NOTE:** Verify that the flex hose can be connected to the supply stop and the control box inlet before installing the control box to the wall.

- Position the control box next to the hole for the spout tube and sensor cables.
- Drill 1/8" (3 mm) pilot holes.
- Use the standard wall anchors (provided) depending on your wall material.
- Attach the control box to the wall with the arrow pointing upward. Secure with the two screws (provided).
- Unthread the control box screws to remove the cover.

## 6. Connect the Control Box

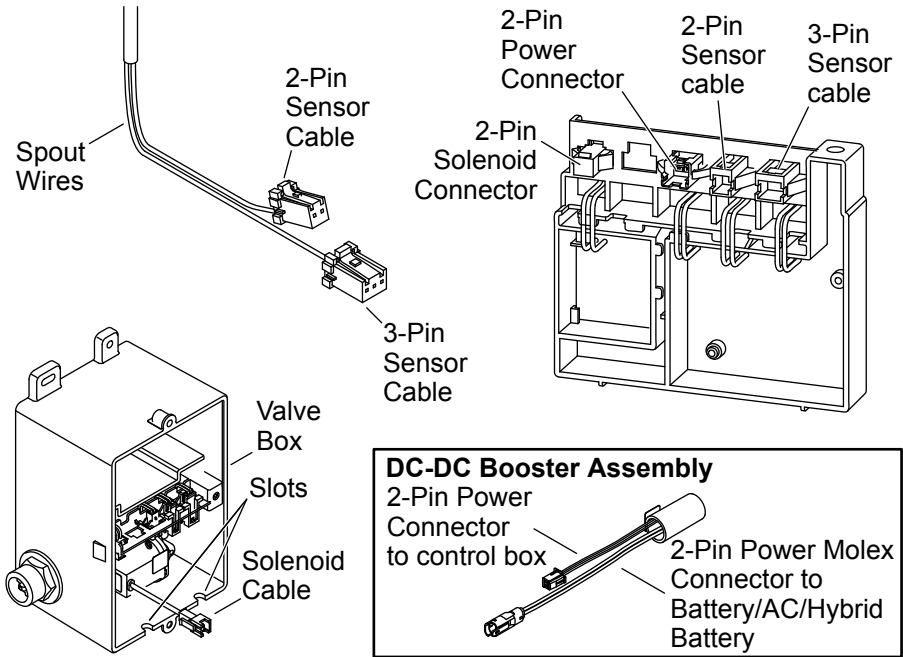

**IMPORTANT!** The control box and cover have slots for the sensor cables. Use care not to pinch the sensor cables when installing the cover.

- Connect the 2-pin power connector (white) from the DC-DC booster assembly to the 2-pin power connector (white) of the control box.
- Connect the 3-pin sensor cable from the valve cover to the 3-pin sensor cable from the spout (red, white, and green cables).
- Connect the 2-pin sensor cable from the valve cover to the 2-pin sensor cable from the spout (orange and black cables).
- Guide the sensor cables through the slots in the control box.
- Loosely secure the cover to the control box for future access.

## 7. Connect the Supplies

---

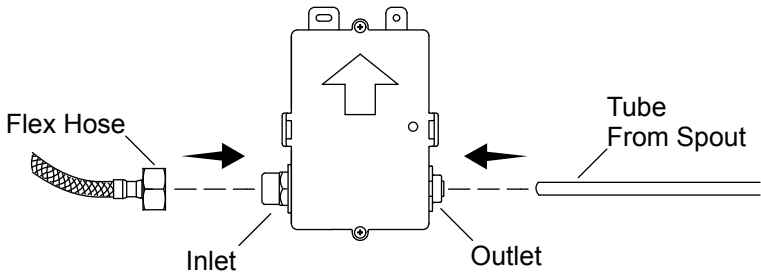
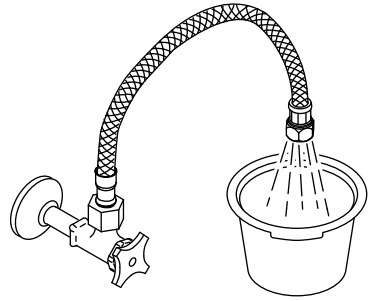
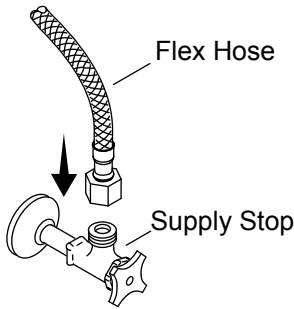

### Inlet Connections

- Connect the flex hose to the supply stop.
- Place a bucket under the supply stop and turn ON the water supply.
- Slowly open the supply stop to flush debris.
- Turn OFF the water.
- Connect the provided flex hose from the supply stop to the control box.

### Outlet Connections

- Verify that the tube from the spout is the appropriate length to reach the control box. Cut the tube if necessary. Remove any burrs and sharp edges.
- Insert the tube into the fitting (control box outlet end) until the tube stops.
- Verify that the tube is secure.

## 8. Install the Mixing Valve (If Included)

---

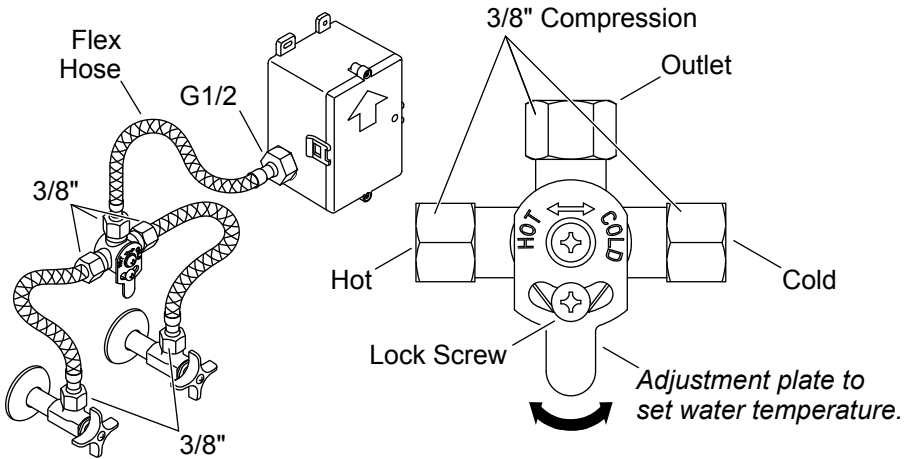

- If a mixing valve is included with your product, connect the flex hoses as shown.
- Attach the provided flex hose to the control box inlet and the outlet of the mixing valve.
- Use a 3/8" compression connection (not provided) to attach the cold supply to the cold inlet on the mixing valve (marked cold on the adjustment plate).
- Use a 3/8" compression connection (not provided) to attach the hot supply to the hot inlet on the mixing valve (marked hot on the adjustment plate).

### Temperature Adjustment

- Loosen the lock screw on the adjustment plate.
- Rotate the adjustment plate to adjust the temperature.
- Retighten the lock screw.

## 9. Install DC Power Unit

---

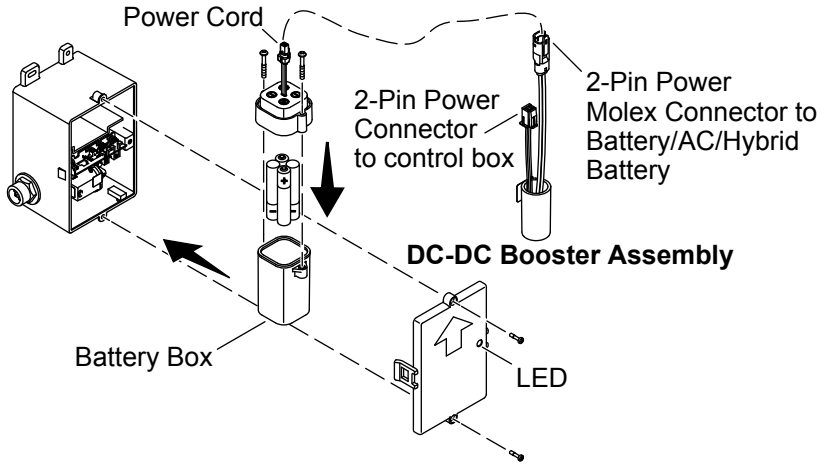

**IMPORTANT!** Verify that you are following the correct power system installation based on your model number. For a hybrid power unit installation, refer to "Install Hybrid Power Unit".

**IMPORTANT!** In the event of leaking batteries, replace the battery box and batteries.

**IMPORTANT!** Use care not to pinch the tube or cables when installing the cover.

**IMPORTANT!** The area in front of the sensor must be free of objects during the 2 minute learning cycle or the faucet may not function properly.

**NOTE:** Do not mix used and new batteries.

- Unthread the control box screws to remove the control box cover.
- Unthread the battery box screws to remove the battery box cover.
- Insert four AA batteries (LR06) (provided). Refer to the battery cover for battery orientation.
- Reinstall the battery box cover and secure with the screws.
- Connect the power cords.
- Place the battery box into the empty space within the control box.
- Secure the control box cover to the control box.
- Allow 2 minutes for the sensor to cycle through the automatic sensing distance.

## **LED Indicator**

**NOTE:** When the faucet is initially connected to an AC or DC power source, the LED will flash to indicate the sensor detection range is auto-adjusting. Do not place any objects in front of the sensor for approximately 2 minutes while the sensor auto-adjusts.

**NOTE:** The LED on the control valve assembly cover will flash RED every 2 seconds when the DC batteries are running low.

- The LED will flash every 6 seconds when the DC batteries are dead. Replace the batteries.

## 10. Install Hybrid Power Unit

---

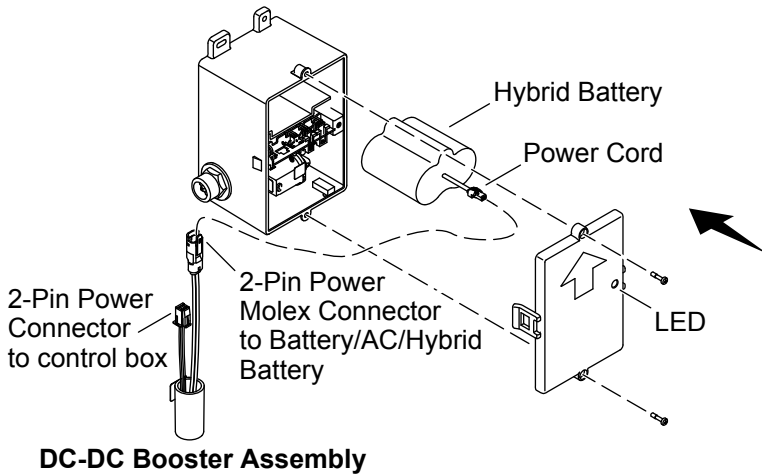

**IMPORTANT!** Verify that you are following the correct power system installation based on your model number. For a DC power unit installation, refer to "Install DC Power Unit."

**IMPORTANT!** In the event of leaking batteries, replace the battery box and batteries.

**IMPORTANT!** Use care not to pinch the tube or cables when installing the cover.

**IMPORTANT!** The area in front of the sensor must be free of objects during the 2 minute learning cycle or the faucet may not function properly.

- Unthread the control box screws to remove the control box cover.
- Connect the power cords.
- Place the hybrid battery into the empty space within the control box.
- Secure the control box cover to the control box.
- Allow 2 minutes for the sensor to cycle through the automatic sensing distance.

# 11. Install the Drain

---

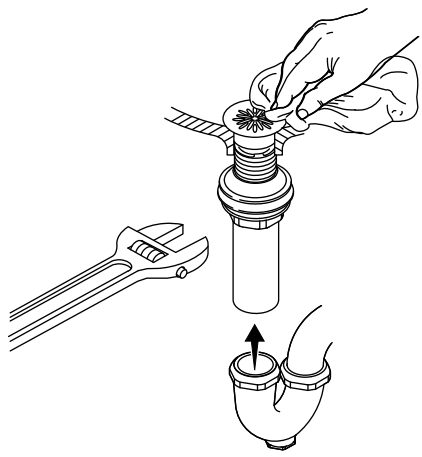
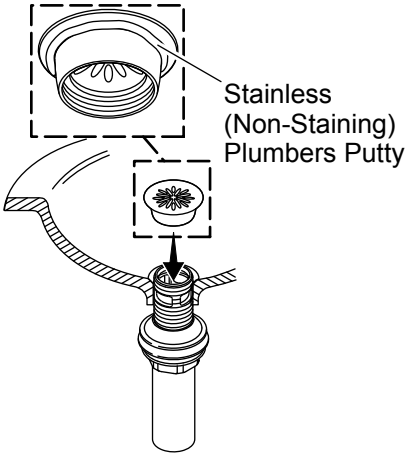

- Disassemble the drain.
- Apply plumbers putty to the underside of the flange and attach.
- Apply thread sealant tape to the drain pipe threads. Tighten the nut.
- Connect the trapway. Wipe away excess plumbers putty.

## Complete the Installation

**NOTE:** Avoid the area in front of the sensor for 2 minutes after connections are complete. The sensor will not function correctly if activated in the first 2 minutes. Disconnect and reconnect the power to reset the sensor.

- Install the faucet trim following the directions provided.
- Activate the faucet and check for leaks.

# Troubleshooting

This troubleshooting guide is for general aid only. For service and installation issues or concerns, call 1-800-4KOHLER.

Symptoms	Probable Cause	Recommended Action
1. No water flow.	<p><b>A.</b> The supply stops are shut OFF.</p> <p><b>B.</b> There is an object in sensing range.</p> <p><b>C.</b> The sensor lens is dirty.</p> <p><b>D.</b> There are no batteries or the batteries are installed in reverse.</p> <p><b>E.</b> There is no power supply or the wrong connections were made.</p> <p><b>F.</b> The filter screen is plugged.</p>	<p><b>A.</b> Turn ON the supply stops.</p> <p><b>B.</b> Remove the object that is in sensing range.</p> <p><b>C.</b> Wipe the sensor lens with a damp soft cloth. Wipe the sensor lens dry with a dry soft cloth.</p> <p><b>D.</b> Check the batteries and adjust the battery orientation.</p> <p><b>E.</b> Check the power supply and connection.</p> <p><b>F.</b> Remove and clean the filter screen.</p>
2. Low flow.	<p><b>A.</b> Supply pressure is low.</p> <p><b>B.</b> The aerator is plugged.</p> <p><b>C.</b> The filter screen is plugged.</p>	<p><b>A.</b> Check incoming water pressure. Pressure should be at least 20 psi (137 kPa).</p> <p><b>B.</b> Remove and clean the aerator. For calcium/mineral deposits, soak the aerator plastic insert in a 50:50 mixture of vinegar and water. Soak only the insert and no other components.</p> <p><b>C.</b> Remove and clean the filter screen.</p>
3. Constant water flow.	<p><b>A.</b> The solenoid is not working.</p>	<p><b>A.</b> Order and install a new solenoid assembly.</p>

Symptoms	Probable Cause	Recommended Action
4. Constant steady drip from the faucet.	A. The solenoid diaphragm is damaged.	A. Order and install a new solenoid diaphragm.
5. Intermittent activation.	A. The faucet is angled incorrectly to the deck or misaligned with the user area. B. The wires are pinched or damaged.	A. Verify that the faucet is mounted according to the installation directions. Verify that the faucet is installed in a position that is above the rim of the sink. B. Remove the spout and verify that the wires are tucked inside the spout before reassembling.
6. The sensor flashes once approximately every 2 seconds.	A. The batteries are out of power.	A. Replace the batteries.

## Compliance

---

This device complies with Part 15 of the FCC Rules. Operation is subject to the following two conditions: (1) this device may not cause harmful interference, and (2) this device must accept any interference received, including interference that may cause undesired operation.

Changes or modifications not expressly approved by the party responsible for compliance could void the user's authority to operate the equipment.

This equipment has been tested and found to comply with the limits for a Class B digital device, pursuant to Part 15 of the FCC Rules. These limits are designed to provide reasonable protection against harmful interference in a residential installation. This equipment generates, uses, and can radiate radio frequency energy and, if not installed and used in accordance with the instructions, may cause harmful interference to radio communications. However, there is no guarantee that interference will not occur in a particular installation. If this equipment does cause harmful interference to radio or television reception, which can be determined by

turning the equipment off and on, the user is encouraged to try to correct the interference by one of the following measures:

- Reorient or relocate the receiving antenna.
- Increase the separation between the equipment and receiver.
- Connect the equipment into an outlet on a circuit different from that to which the receiver is connected.
- Consult the dealer or an experienced radio/TV technician for help.

This Class B digital apparatus complies with Canadian ICES-003.