

SIDES	BOTTOM
4 1/2"-3/4" MOON KNOCKOUTS	3 1/2" KNOCKOUTS
	2 3/4" KNOCKOUTS
2 PCS #6-20×1-3/4 Type AB Screws Installed	
2 PCS 8-32×1/2 Screws Installed	
Material: Steel-0.0625"-G60 Galvanized	

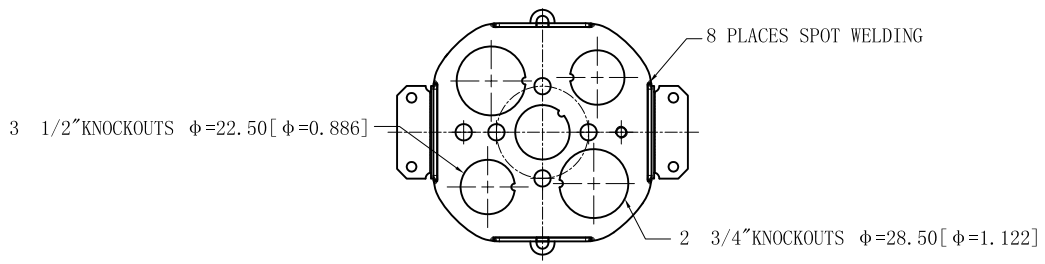
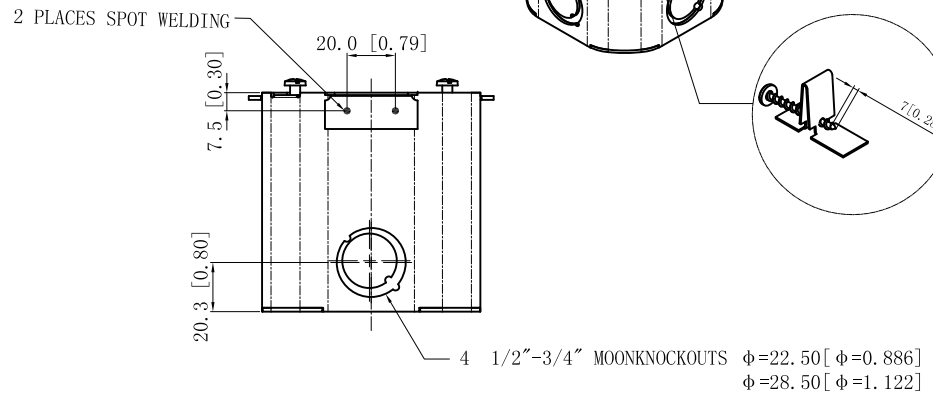
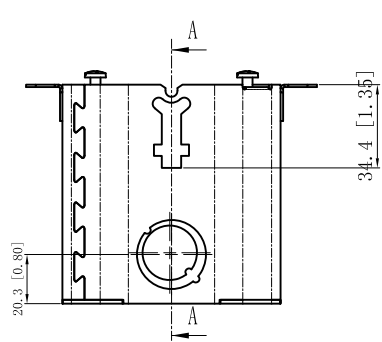
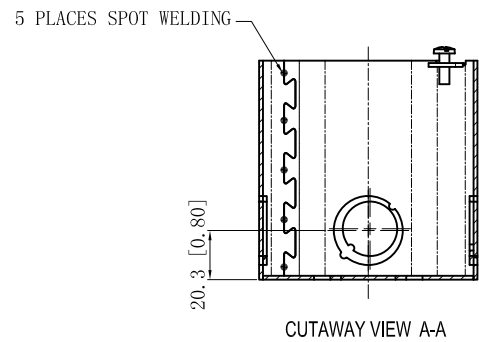
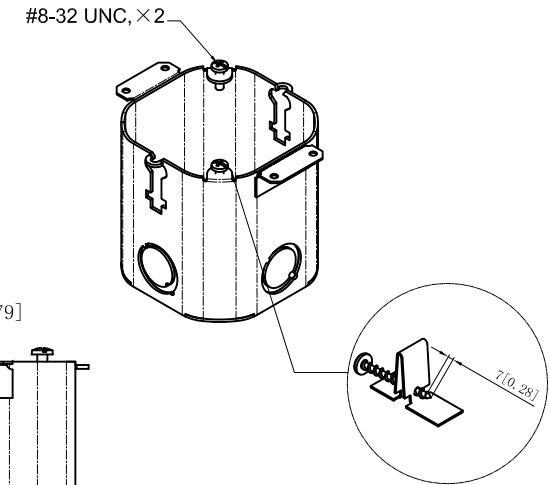
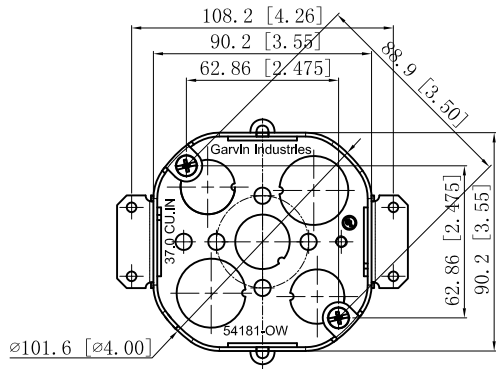

This data sheet is for reference only .GARVIN INDUSTRIES reserves the right to make changes to the design without prior notice.

TRADE REFERENCE TERMS	STANDARD PACKING	GARVIN INDUSTRIES		
	10 PCS			
		SIZE	DWG NO.	REV
	A4	54181-OW	D	
		DATA SHEET		
		www.garvinindustries.com		