

SIDES	BOTTOM
1 Pcs TWH-300 Sealing ring	
1 Pcs TWH-300 With Insulated throat	

REVISIONS			
SYM.	BY.	REVISIONS	DATE
A.			

TWH-300 Sealing ring

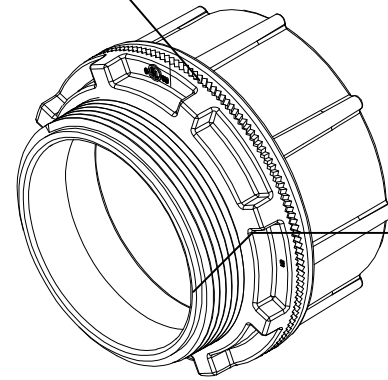

TWH-300 With Insulated throat

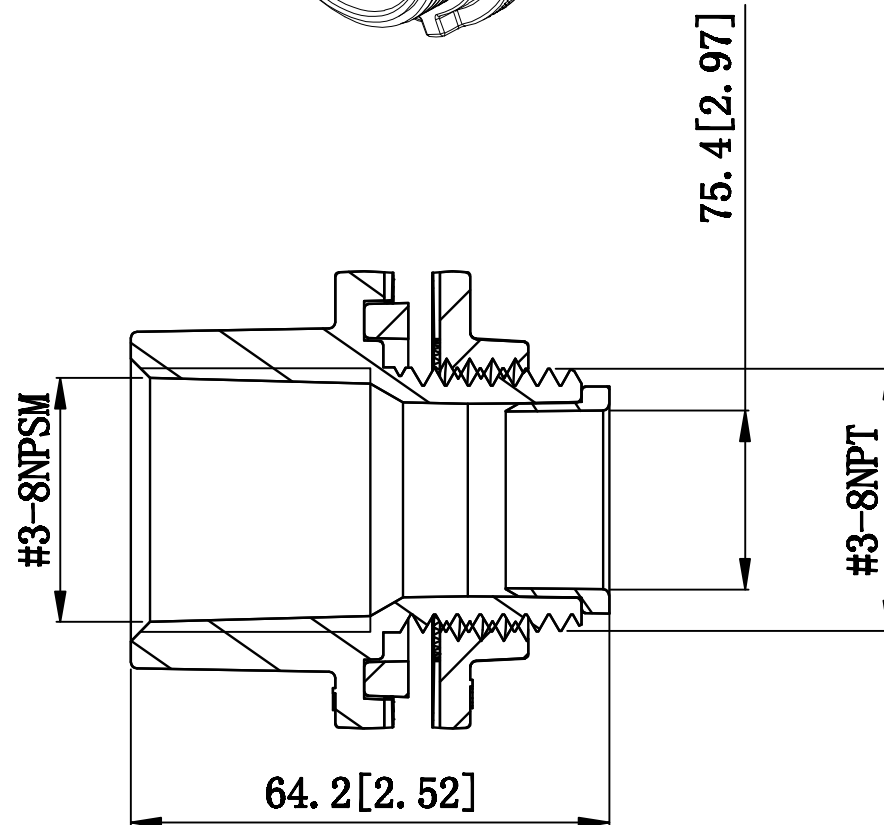
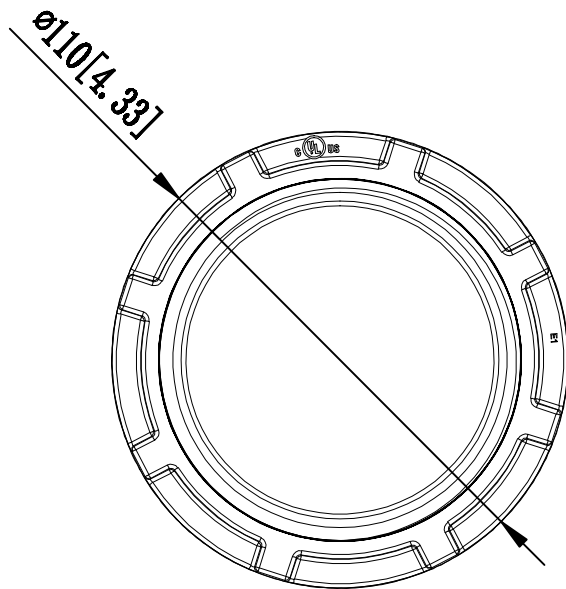

NOTES:
 1.All dimensions in millimeters and [inches];
 2.Free of sharp edge and burrs.max burr 0.5[0.0196].

UNLESS OTHERWISE SPECIFIED DIMENSIONS ARE IN INCHES TOLERANCES ARE: X.X: ±2.54[±0.1] X.XX: ±1.27[±0.05] X.XXX: ±0.203[±0.008]		NAME	DATE
	DRAWN		
	CHECKED		
	APPROVED (A)		
MATERIAL ZAMAK	APPROVED (Customer)		
FINISH	THIS DOCUMENT IS THE CONFIDENTIAL PROPERTY OF GARVIN INDUSTRIES AND IS LOANED SUBJECT TO RETURN UPON DEMAND. TITLE TO THIS DOCUMENT IS NEVER SOLD OR TRANSFERRED FOR ANY REASON. THIS DOCUMENT IS TO BE USED ONLY PURSUANT TO WRITTEN LICENSE OR WRITTEN AND TRUE TERMS OF GARVIN INDUSTRIES. ALL RIGHTS TO DESIGN AND INVENTIONS ARE RESERVED BY GARVIN INDUSTRIES. POSSESSION OF THE DOCUMENT IS ACCEPTED SUBJECT TO THE FOREGOING.		
DO NOT SCALE DRAWING INTERPRET PER ASME Y14.4M-1994			

GARVIN INDUSTRIES

TITLE			
SIZE A4	DWG NO. WH300	REV	
SCALE: 1:1	PRINT DATE	REFERENCES	SHEET 1 OF 1

