

HOOKER[®]

— FURNITURE —

ASSEMBLY INSTRUCTION

Item#: 5805-85001-80 Flip-Top Console

** Please make sure you have all parts indicated below prior to assembly.
 This table is heavy and can best be assembled with the help of two persons.

NO	HARDWARE LIST		Q'TY
A		$\frac{5}{16}$ " 30MM ALLEN BOLT	4
B		LOCK WASHER	14
C		22MM FLAT WASHER	4
D		ALLEN WRENCH	1
E		$\frac{5}{16}$ " 15MM ALLEN BOLT	10
F		16MM FLAT WASHER	10

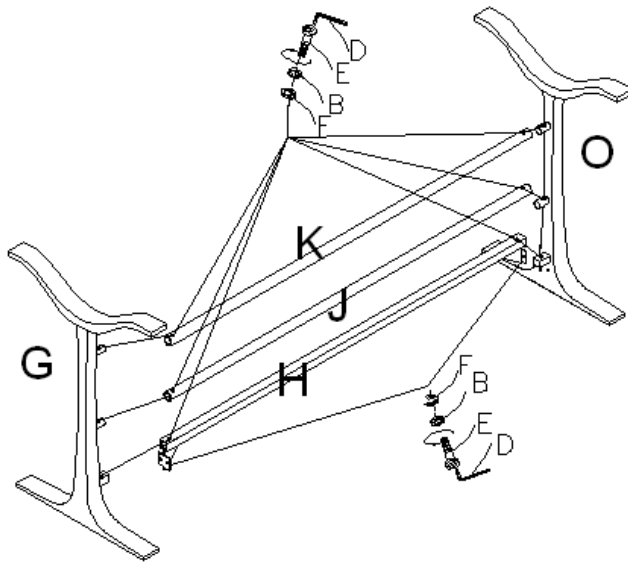
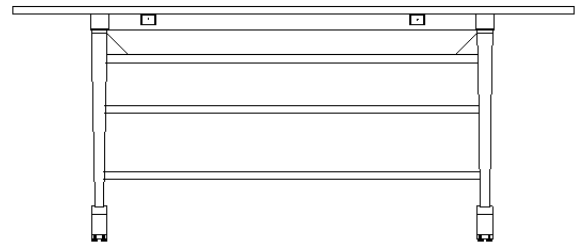

Diagram 1

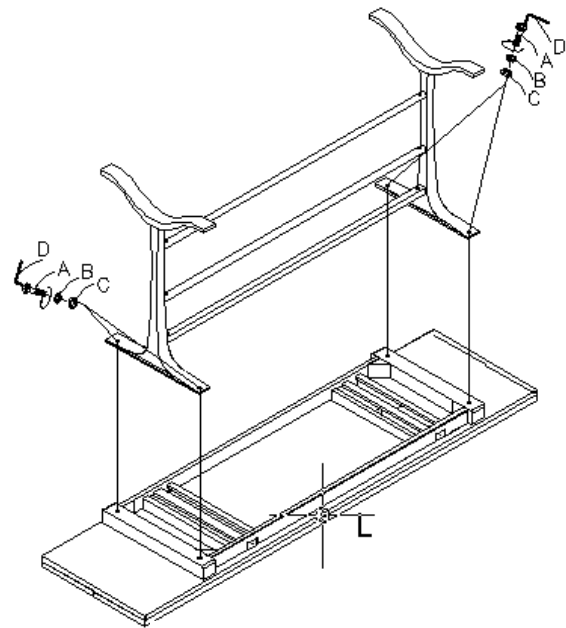
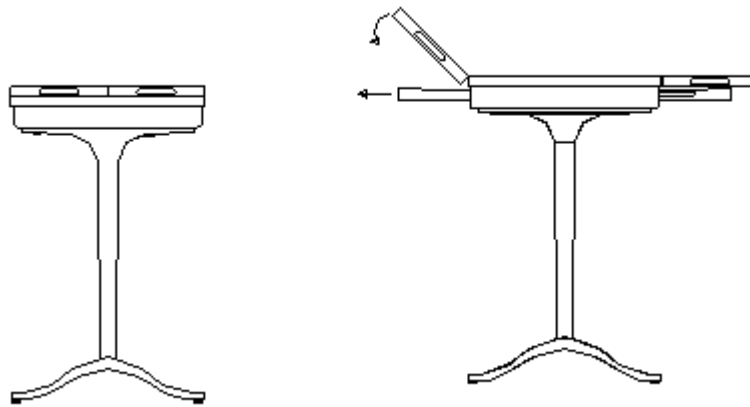

Diagram 2

Assembly Steps:

1. Put two leg frames (G&O) upside down on a soft surface to prevent it from being scratched (See Diagram 1).
2. Place the ends of top stretcher(H) , center stretcher (J) and bottom stretcher (K) into left & right leg frames (G&O) make sure all pre-drilled holes are in alignment.

3. First use bolts (E), lock washers (B) and flat washers (F) to secure all by turning with allen wrench (D) to assemble the top stretcher (H) from bottom and side (See Diagram 1).
4. Then use bolts (E), lock washers (B) and flat washers (F) to secure all by turning with allen wrench (D) to assemble the center stretcher (J) and bottom stretcher (K) from bottom (See Diagram 1).
5. Put table top (L) upside down on a soft surface to prevent it from being scratched (See Diagram 2).
6. Put whole base onto top to make sure all pre-drilled holes are in alignment, well insert bolts (A), lock washers (B) and flat washers (C), tighten bolts by turning with allen wrench (D) in clockwise direction (See Diagram 2).
7. Turn table upright.
8. Pull out the bars ,the table top can flip as below.



Cleaning Instruction: Clean finished parts with a damp cloth using a mild dishwashing liquid and water solution. Polish the finish with soft cloth and an industry recognized furniture polish.