

料号	客户
NET-901361	HILLS
NET-006305	KOA

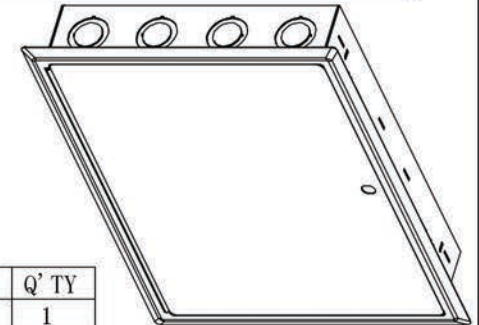

ITEM	PART NO.	MATERIAL	Q' TY
1	RS-300/A Frame+Base	STEEL PLATED WITH LACQUER(T=1.2mm)	1 set
2	lock	ZINC PLATED WITH NICKEL	1
3	NTLON MOVABLE	NYLON 66 UL94-V2	800mm
4	Tie Wrap Cable Mount	TDE WRAP	20
5	Adjuct Buckle	Nylon	10
6	KEY	BRASS PLATED WITH NICKEL	2
7	SCREW(6*46PA)	STEEL PLATED WITH ZINC	4
8	SCREW(4*18PM)	STEEL PLATED WITH ZINC	1
9	Special Screw(4.2*13)	Stainless Steel	4
10	LCS-5 fixed leg	Nylon	6

ITEM	PART NO.	MATERIAL	Q' TY
11	RS-300/A Bracket	STEEL PLATED WITH LACQUER(T=1.2mm)	1
12	The buckle of nylon	Nylon	4

				DESCRIPTION	FINISHED PRODUCTS	SCALE	FIT	UNITS:mm	3rd ANGLE
				MODEL NO,	RS-300/A	△			
APPROVED	CHECKED	DRAWING	DESIGNED	DRAWING NO,		△	2017/01/16		A2
Hgh		Hgh		FINISHING		△	2013/07/30		A1
				MATERIAL		SYM	DATE		REVISION