



---

**Extended Warranty  
Sign Up**

---

**E-1**

# Welcome home!

**ELG-501**

**TEAMSON HOME  
Martha Wall Cabinet  
2 Doors**

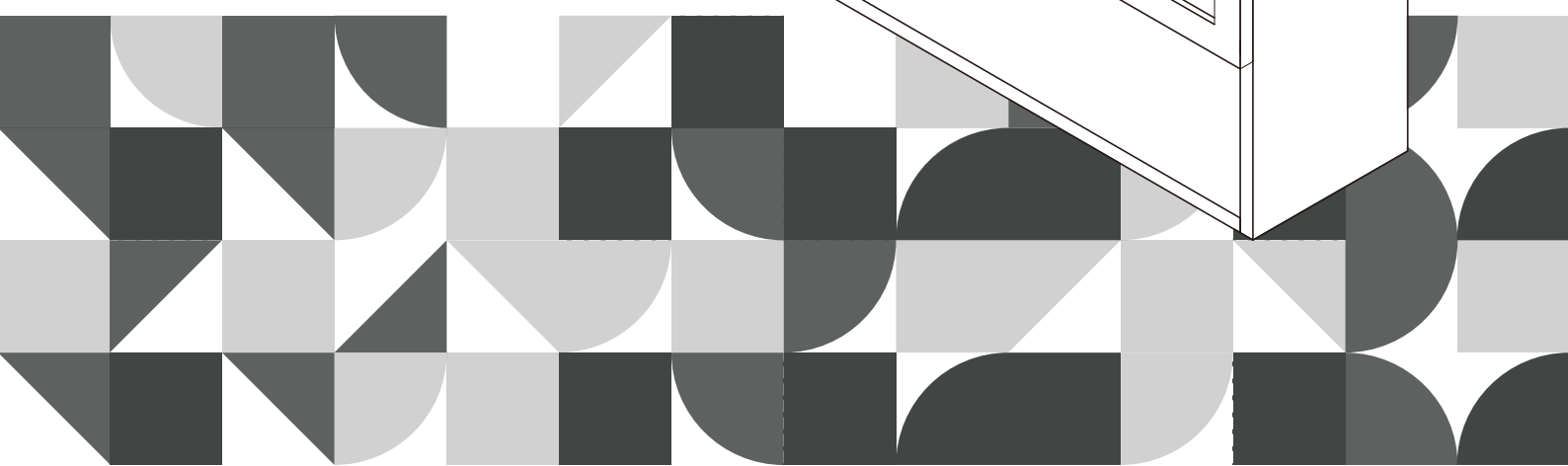
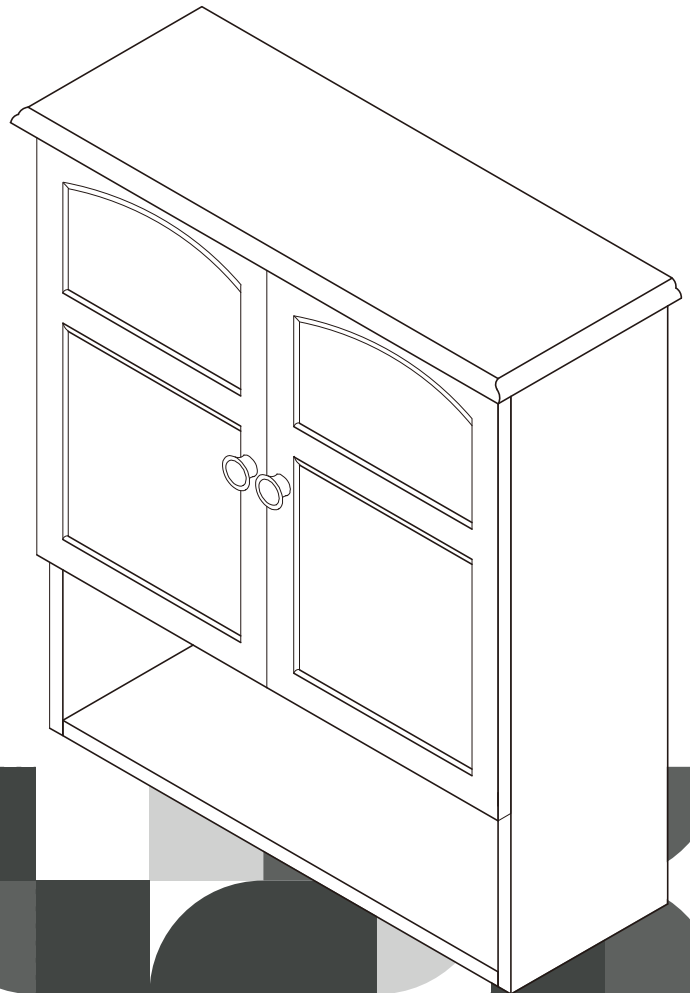



**Questions? Comments? Need help?  
Call or email us any time!**

## Global Customer Service

**USA**

**+1(800)935-3959**

Mon - Fri 10:00am ~ 2:00pm EST

✉ [support@teamson.com](mailto:support@teamson.com)

**EU/UK**

**+44(0)1952-916-050**

Mon - Thu 9:00am ~ 5:00pm GMT

Friday 9:00am ~ 4:00pm GMT

✉ [support@teamson.co.uk](mailto:support@teamson.co.uk)

**ASIA**

深圳办公室:

**+86(0755)8885-3558.分机号331**

Mon - Sat 9:00am ~ 5:00pm GMT+8

✉ [sales\\_ec@teamson.com](mailto:sales_ec@teamson.com)

台北办公室:

**+886(2)2556-6268**

Mon - Fri 9:00am ~ 5:00pm GMT+8

✉ [sales\\_ec@teamson.com](mailto:sales_ec@teamson.com)

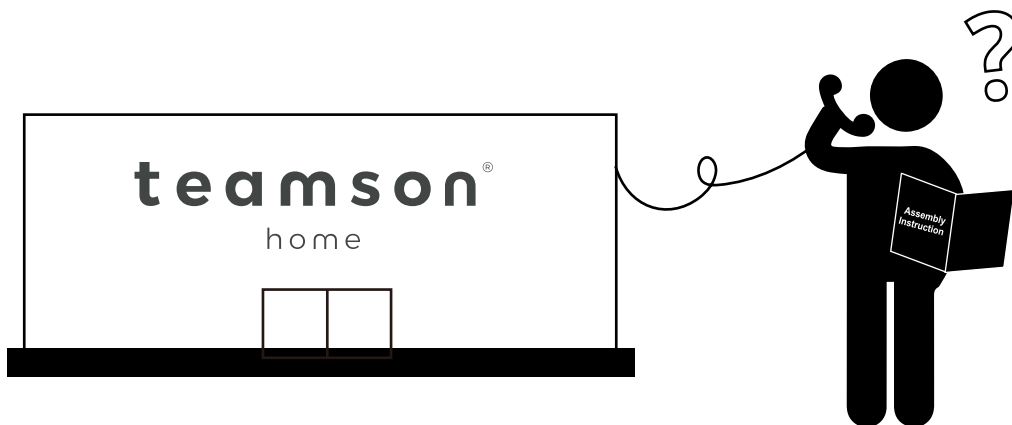
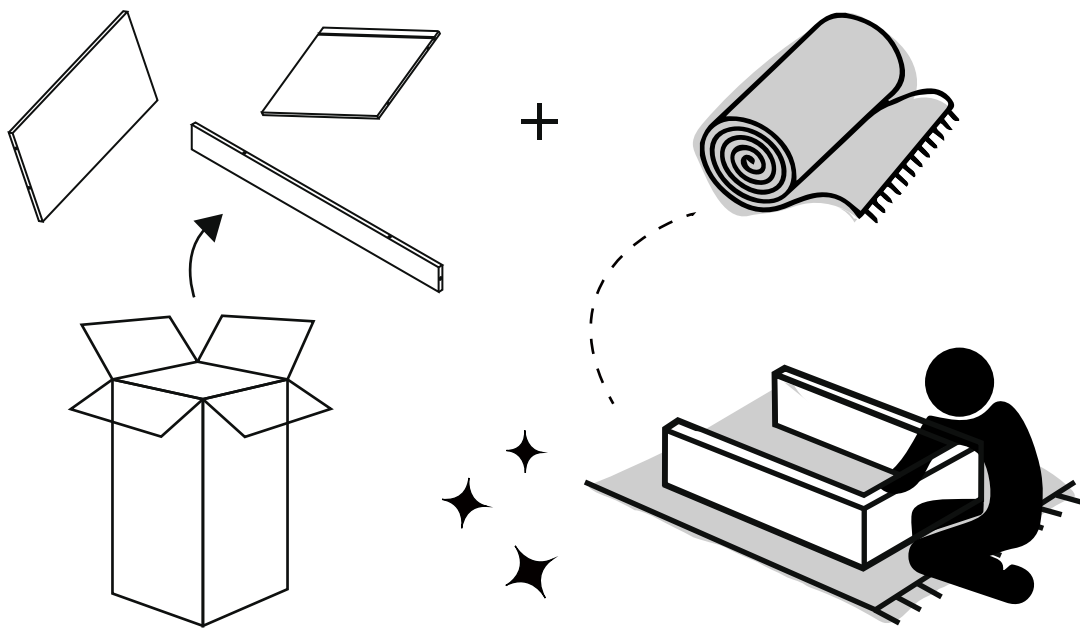
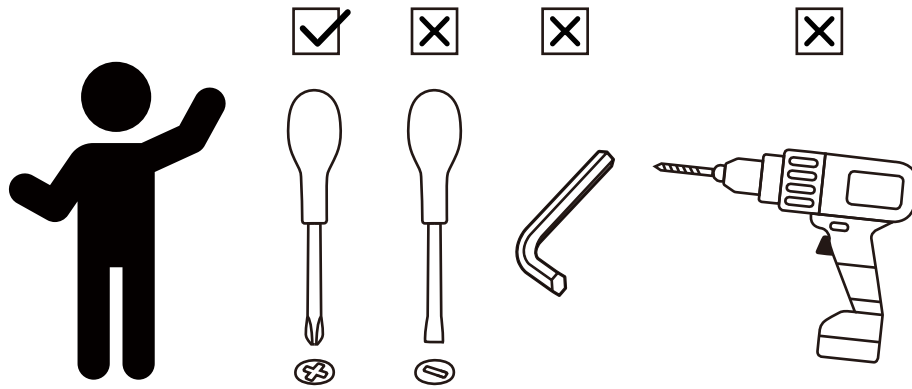

\*\* Got questions? Please have your product code (on the first page of this instruction, e.g. TD-12345A) and the order number ready, give us a call or email us through our customer care support! We are always ready to assist you!

# Exploded Drawing

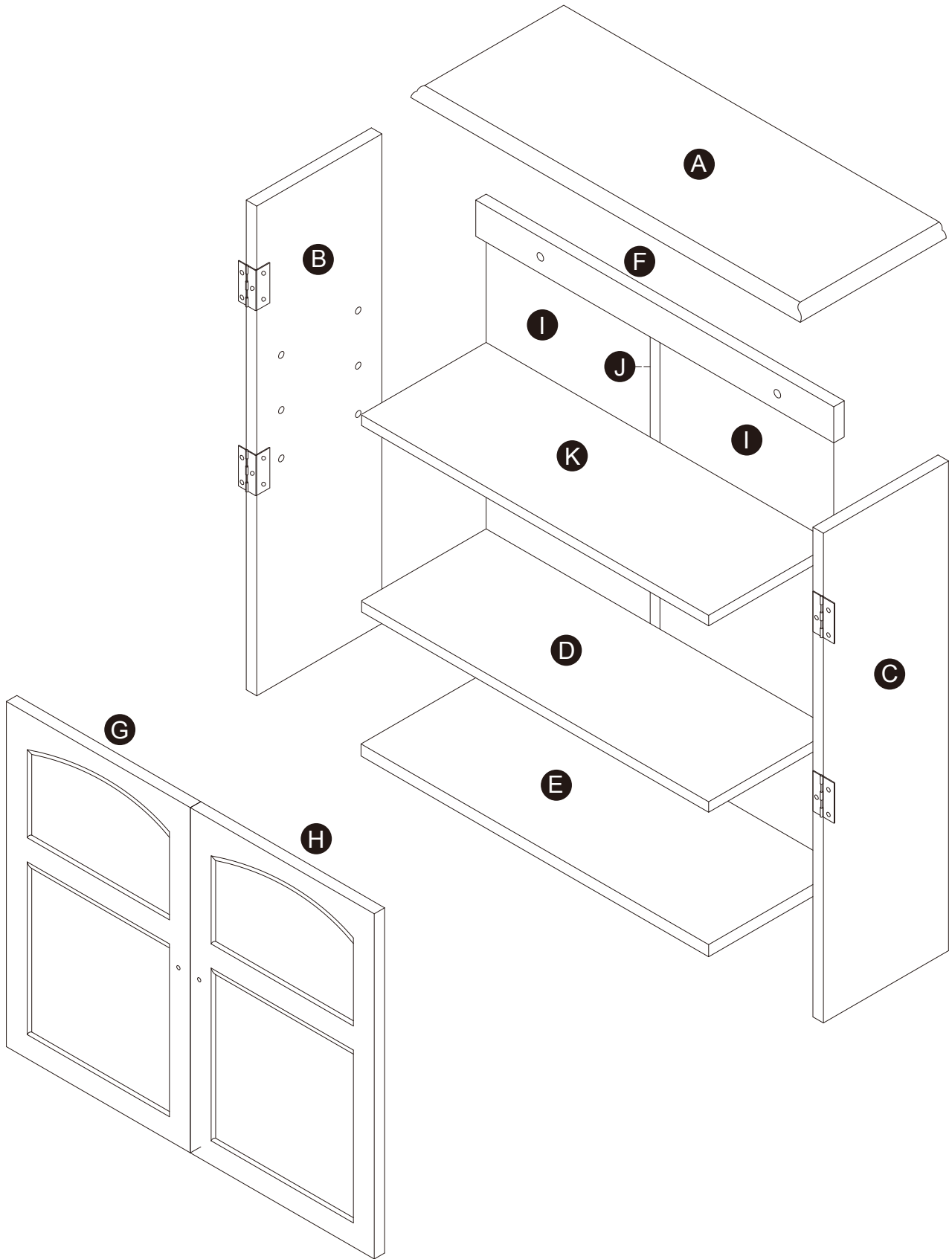

Scan for assembly instructions.

## Product Parts

A

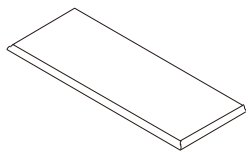

1 PC

B



1 PC

C



1 PC

D

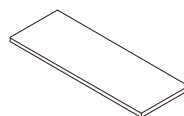

1 PC

E

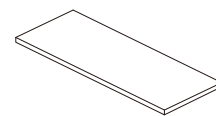

1 PC

F

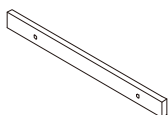

1 PC

G

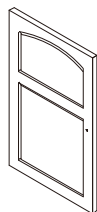

1 PC

H

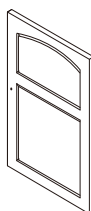

1 PC

I



2 PCS

J

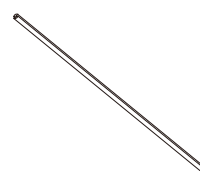

1 PC

K

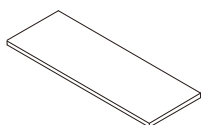

1 PC

### ! Care Instructions

Dust surface with a dry soft cloth. Do not use window cleaners or cleaning abrasives as they will scratch the surface and could damage the protective coating

### ! WARNING

Small parts and sharp edges may be present prior to assembly.



Scan for assembly instructions.

# Hardware

1

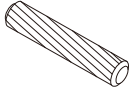

Ø8\*30mm

18 PCS

2

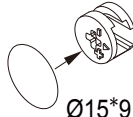

Ø15\*9

2 PCS

3



Ø15\*12

8 PCS

4

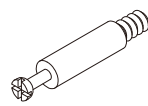

10 PCS

5

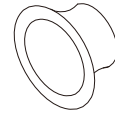

2 PCS

6

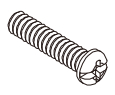

2 PCS

7



Ø3\*12

8 PCS

8



Ø3\*12 D=7

14 PCS

9

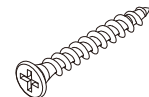

Ø4\*35

2 PCS

10

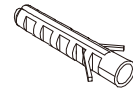

2 PCS

11



4 PCS



Scan for assembly instructions.

# Step 1

- 1  12 pcs  $\text{Ø}8 \times 30\text{mm}$
- 2  1 pc  $\text{Ø}15 \times 9$
- 3  2 pcs  $\text{Ø}15 \times 12$
- 4  6 pcs

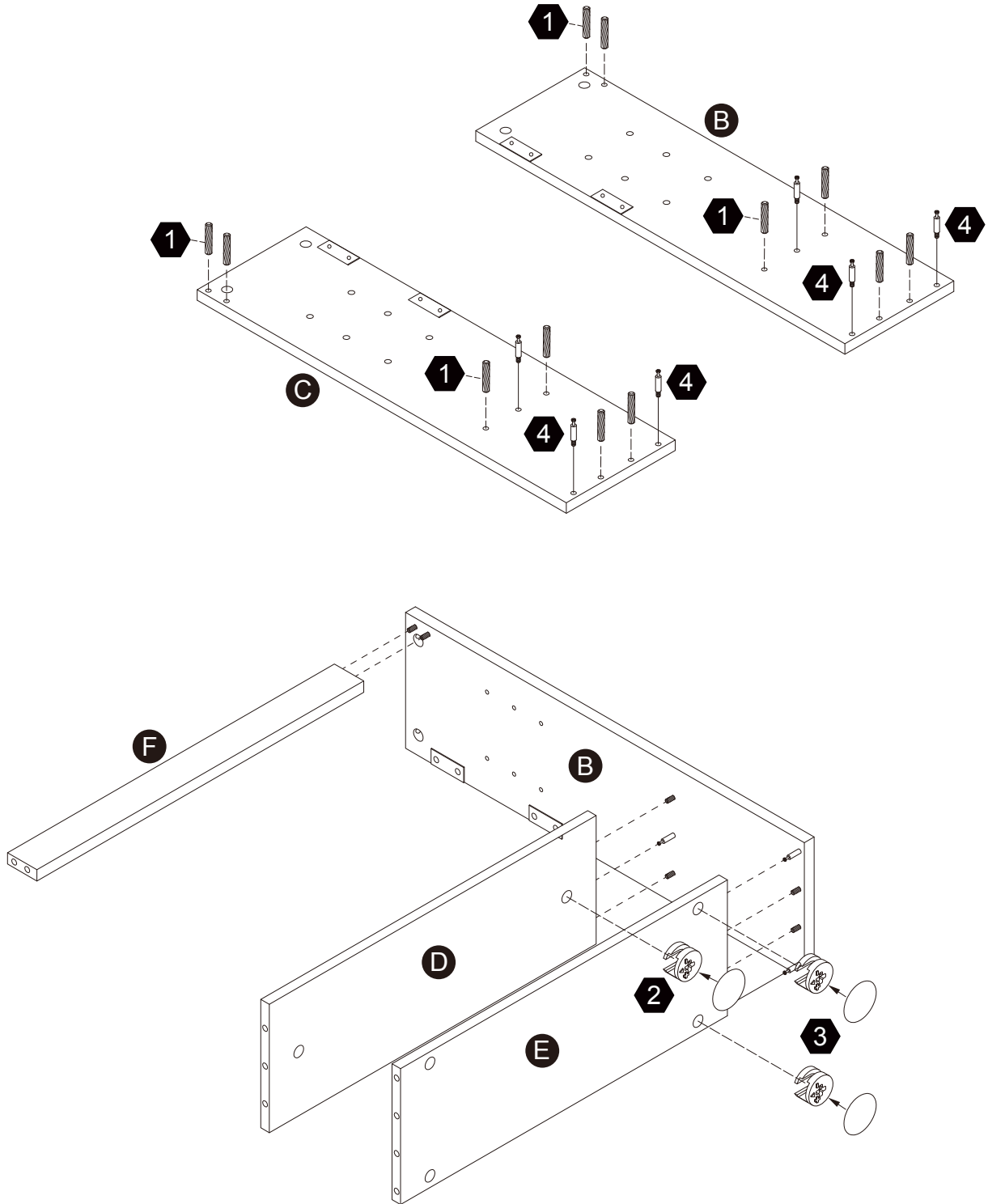

Scan for assembly instructions.

## Step 2

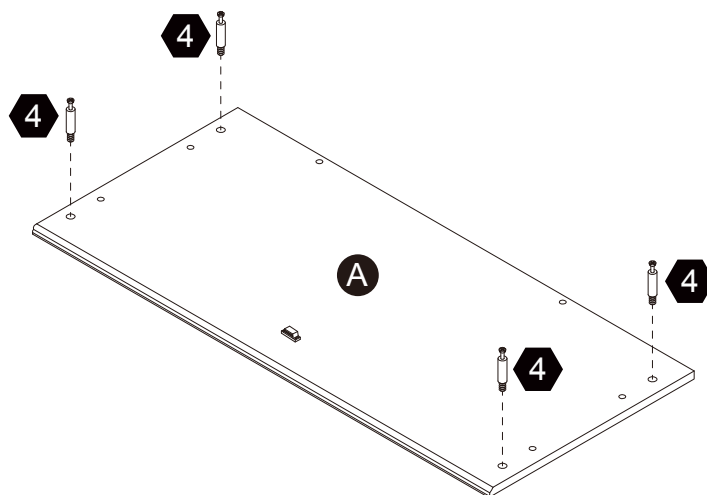
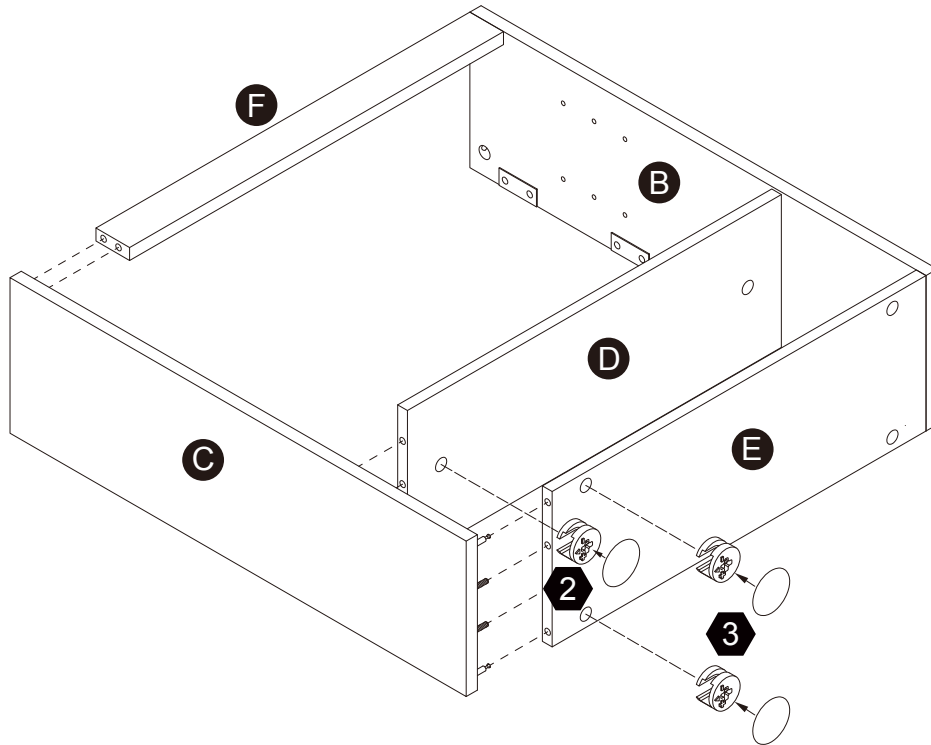
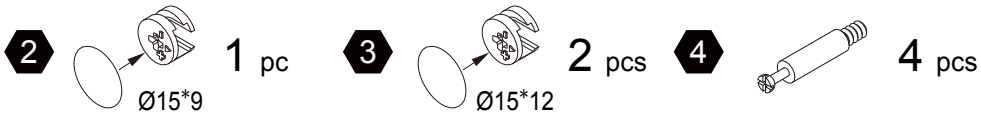

Scan for assembly instructions.



## Step 3

1



6 pcs

3

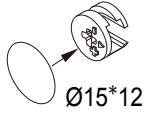

4 pcs

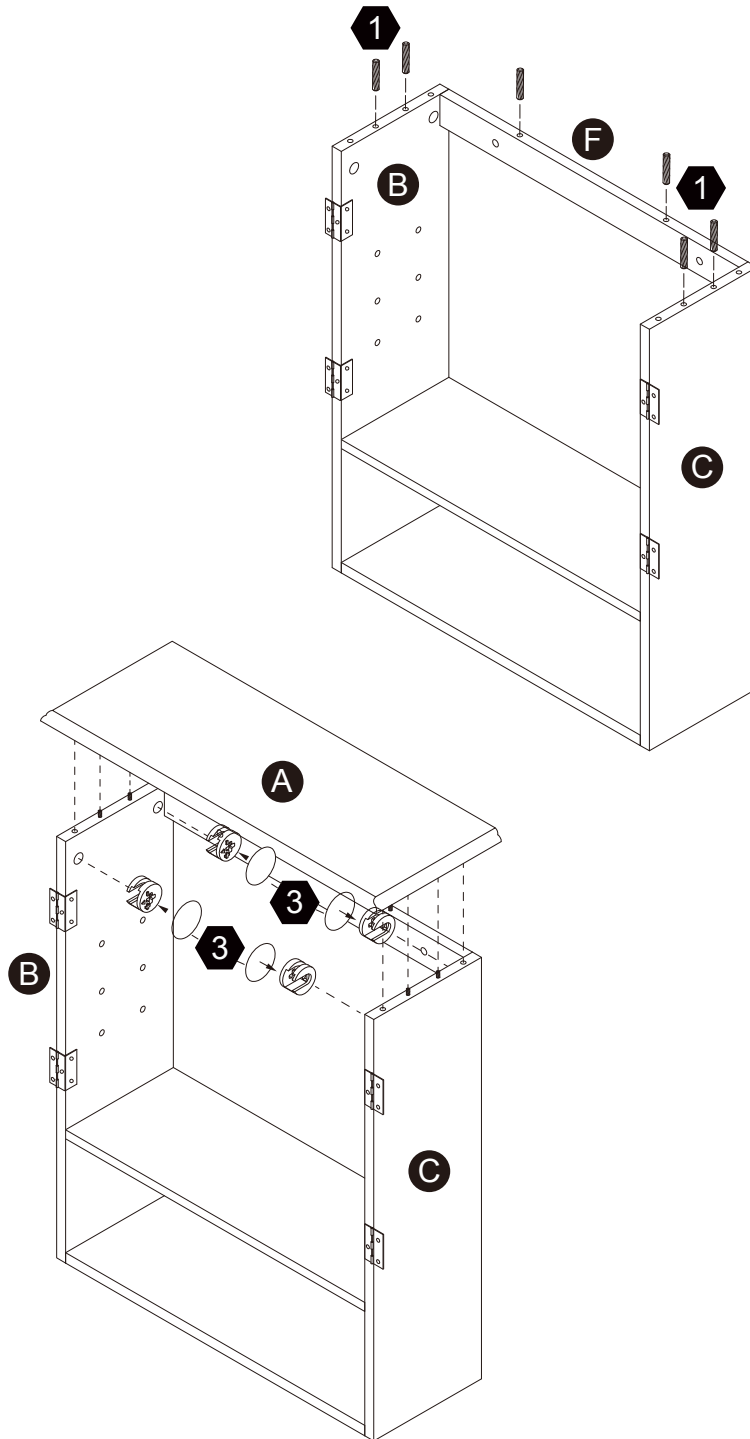

Scan for assembly instructions.

## Step 4

8



14 pcs

Ø3\*12 D=7

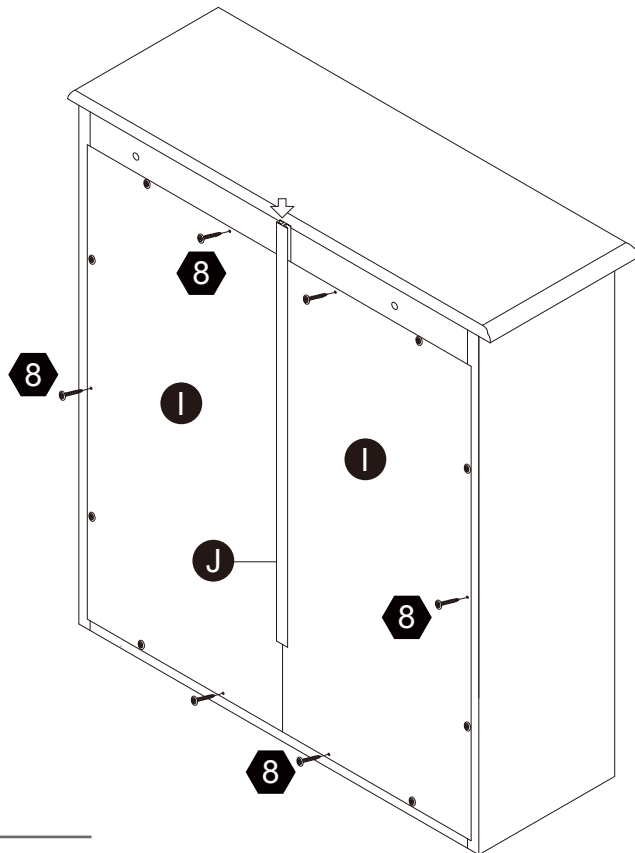
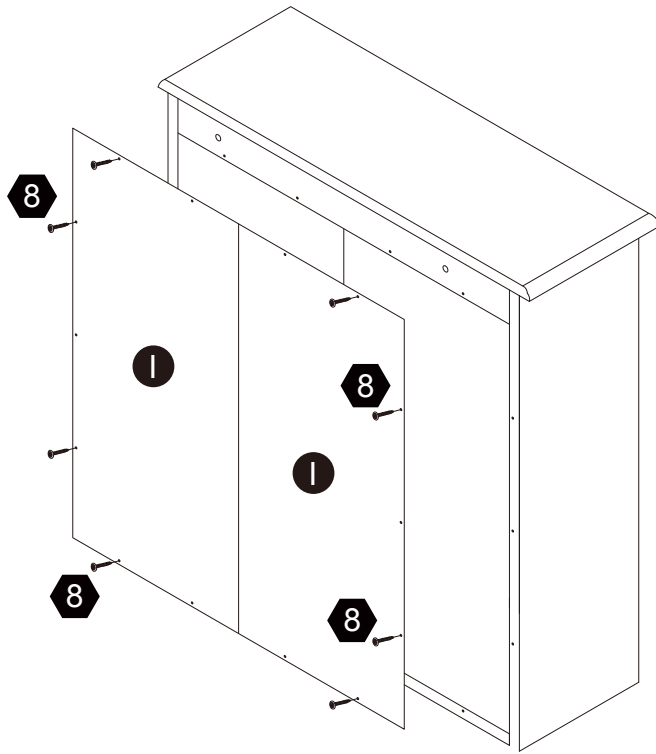

Scan for assembly instructions.

## Step 5

5



2 pcs

6

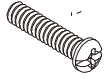

2 pcs

7



Ø3\*12

8 pcs

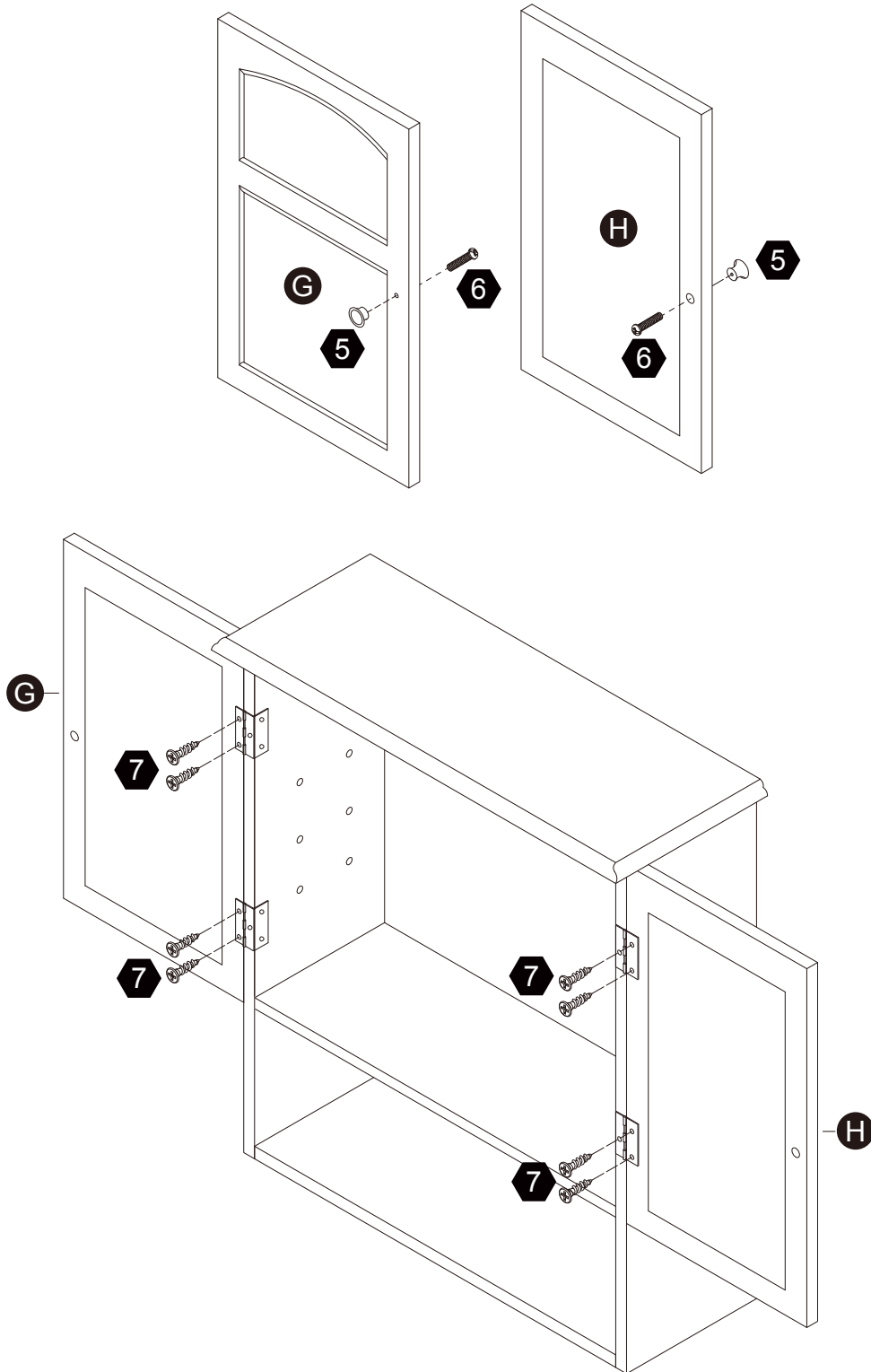

Scan for assembly instructions.

## Step 6

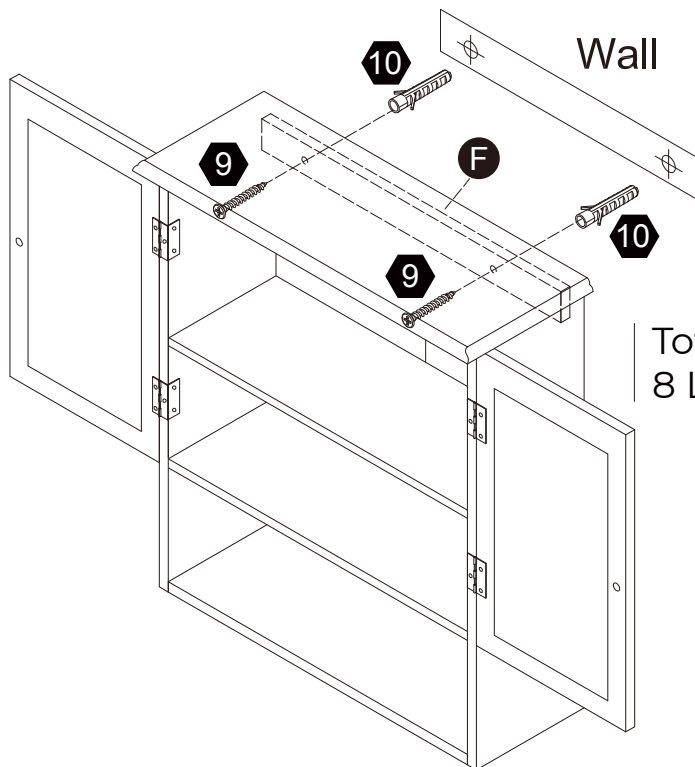
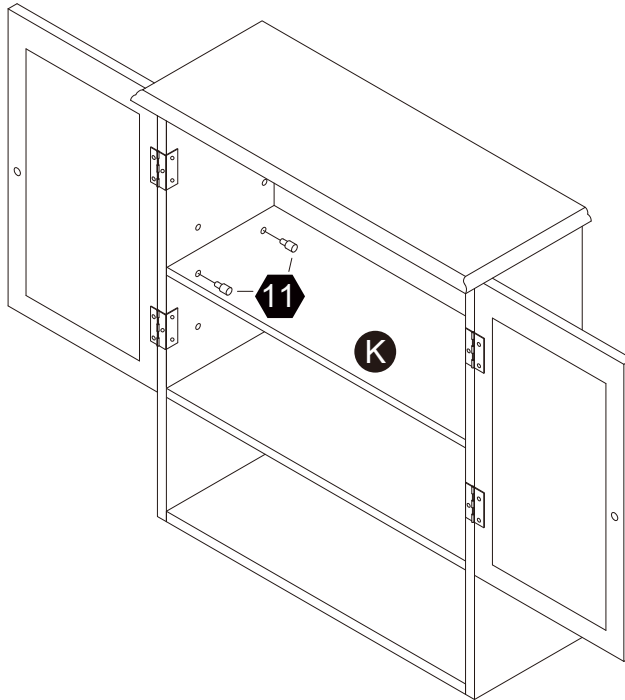
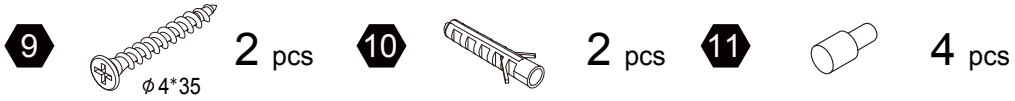

Total Max Load 24 Lbs(10.9kg)  
8 Lbs(3.6kg) per shelf



Scan for assembly instructions.