

COMBINATION BENCH & PIPE VISES

Palmgren's new bench vise looks different for a reason. It is built different than all other vises. The unique shaped body houses the straight-line pull, super strong power tunnel that assures that the spindle and nut will never wear out. The entire vise is made of 65,000 PSI ductile iron - coupled with our exclusive manufacturing process of the body and nut – delivers a vise that is 50% stronger than all gray iron vises and 20% stronger than competitive ductile iron vises. Palmgren vises are built for performance and endurance to handle any of your workholding requirements.

STANDARD FEATURES:

- Straight line pull design – horizontal spindle and nut eliminate thread wear, increases clamping power, reduces drag for easier closing and opening of the vise
- Replaceable large hardened steel jaws that are serrated for maximum sure gripping under maximum torque
- Replaceable self-centering hardened steel pipe jaws for maximum working capacity
- Enclosed construction that keeps contaminants out and lifetime lubrication in
- Perfect for both indoor and outdoor use
- Precision slide bar machined for a .002" fit
- Extra deep throat gives you more working room where it counts
- Oversized anvil provides structural integrity and consistent properties of toughness and hardness
- Locking swivel base with 360 degree rotation enhanced by double lockdowns for non-slip hold in any position
- Lifetime warranty

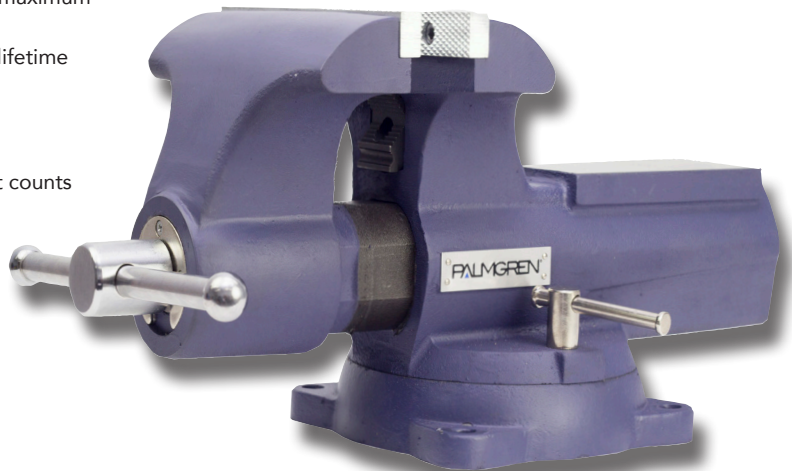

Item #	Capacity			Anvil	Dimensions	
	Jaw Width	Jaw Opening	Clamping Force (Max)	Anvil Length x Width	Overall Dimensions	Weight
9629756	6.5"	8.5"	65,500 PSI	3.5" x 5.75"	18" x 10" x 10"	73 lbs.
9629758	8.5"	9"	74,000 PSI	3-5/8" x 7"	21" x 12" x 10"	102 lbs.

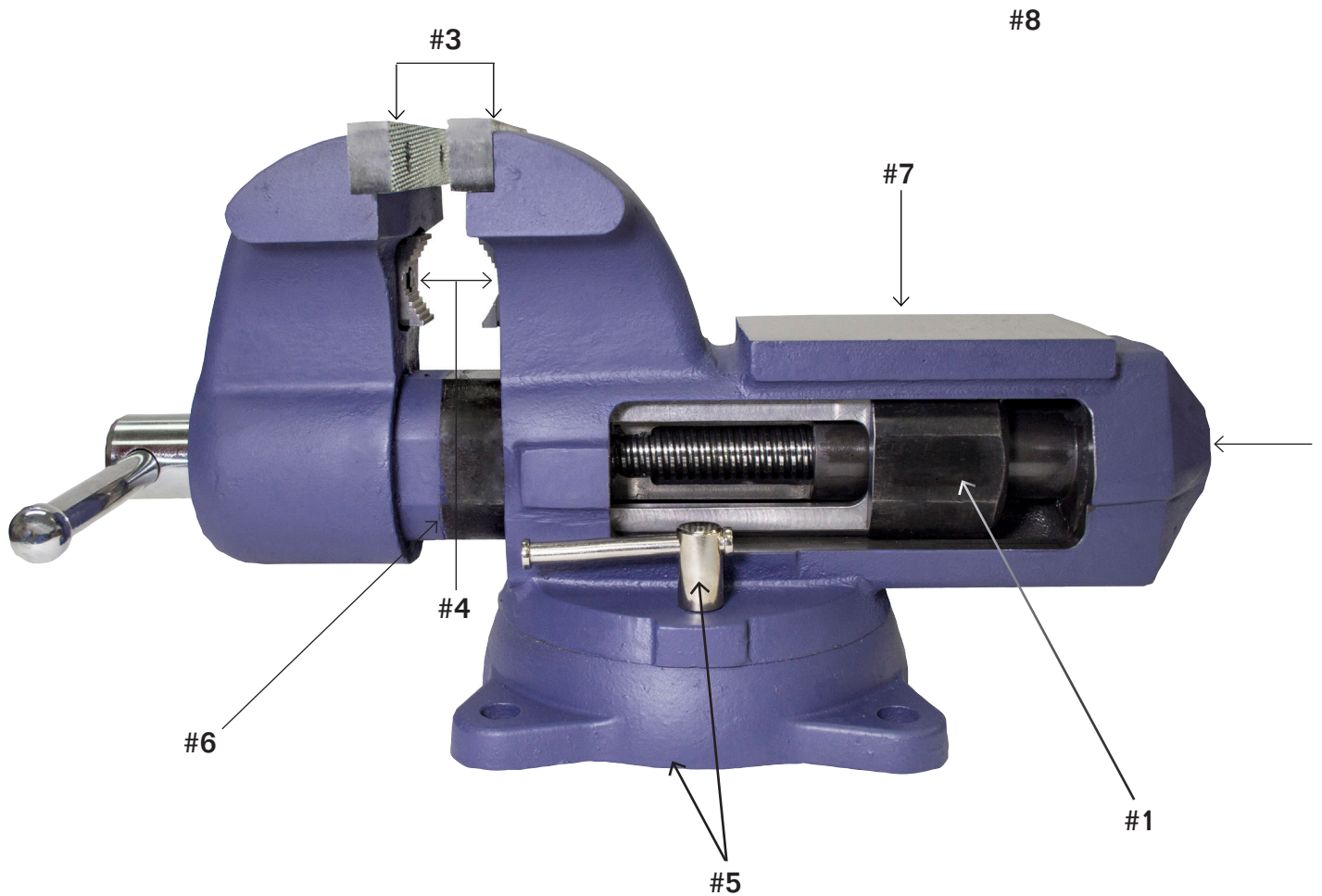

1. Straight line power tunnel design – unbreakable spindle & nut with increased clamping power
2. Enclosed construction keeps lubrication in & contaminants out making it ideal for both indoor & outdoor use
3. Hardened replaceable steel jaw inserts ensures positive hold
4. Hardened replaceable steel self-centering pipe jaws hold round materials securely
5. Locking swivel base with double lockdowns for non-slip hold in any position
6. Precision fit slide bar
7. Oversized machined anvil for greater working area
8. All vise parts are made from 65,000 PSI ductile iron castings for greater strength and performance