

# ChildLife<sup>®</sup>

## Playsets

PG123MRW

MONKEY ROOM

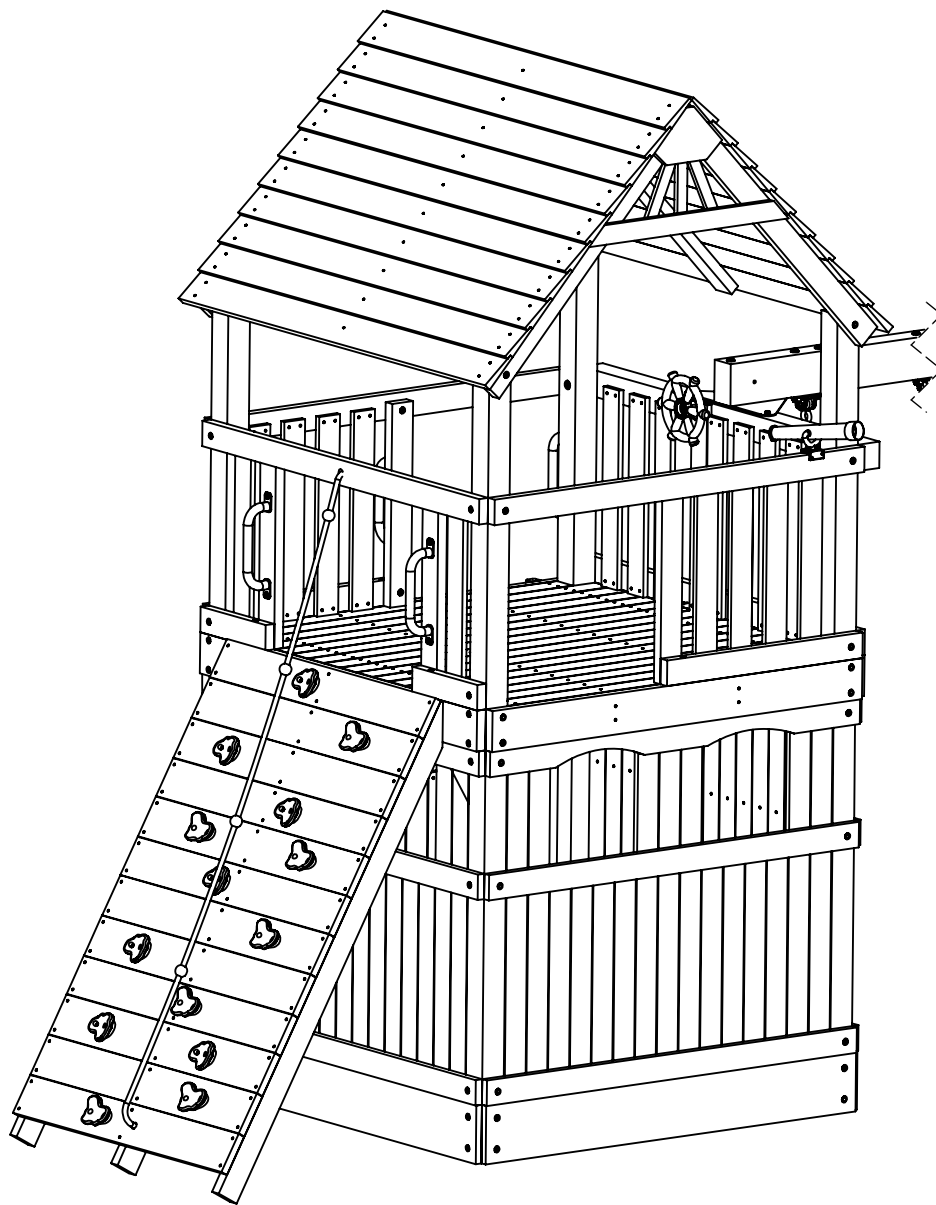

PG-MA-0024-01

## STANDARD PARTS LIST

ITEM NO.	PART NUMBER	DESCRIPTION	QTY.
1	PG-54-0006	Picnic Table Board Long	2
2	PG-54-0012	Enclosure Window Front	2
3	PG-54-0013	Enclosure Door Front	1
4	PG-54-0014	Enclosure Rail Opened	2
5	PG-54-0016	Enclosure Rail	7
6	PG-14-0010	28 1/2" Enclosure Slat	20
7	PG-14-0013	43 3/4" Enclosure Slat	34
8	PG-54-0015	Enclosure Rail Short	2
9	PG-HW-S003	#8 X 1.5" FLAT HEAD WOOD SCREW	250
10	PG-HW-S004	#8X2" FLAT HEAD WOOD SCREW	10
11	PG-HW-L003	5/16" X 2.5" LAG SCREW	24
12	PG-HW-W003	5/16" FLAT WASHER	24
13	PG-HW-M001	Bracket	1
14	PG-HW-S001	#10 X 1" ROUND HEAD SCREW	4
15	PG-HW-W001	#10 FLAT WASHER	4

### PARTS USED INCLUDED WITH BASE SET

FOR EASE OF IDENTIFYING PARTS RE-LABEL PARTS FROM THE BASE SET AS SHOWN BELOW. IN THE FOLLOWING INSTRUCTIONS PARTS WILL BE REFERRED TO AS THE "NEW #".

OLD#	NEW#	PART#	DESCRIPTION	QTY.
24	1	PG-54-0006	Picnic Table Board Long	13
55	10	PG-HW-S004	#8X2" Flat Head Wood Screw	75
23	PART #	PG-54-0005	Picnic Table Board Short	2
08	PART #	PG-24-0002	Safety Rail	3
53	PART #	PG-HW-L004	5/16" x 3" Lag Screw	4
47	PART #	PG-HW-W003	5/16" Flat Washer	4

# HARDWARE IDENTIFICATION

## NOTE TO INSTALLER

You must assemble this product in accordance with these Assembly Instructions.  
After assembly is complete, please give this Owner's Manual to the owner of the play system.

## Measurement taken from bottom of bolt head to the bottom of bolt

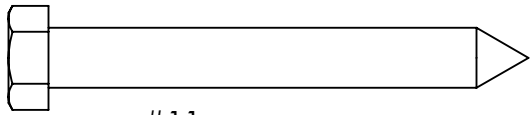

#11  
PG-HW-L003  
5/16" X 2.5" LAG SCREW  
QTY (24)

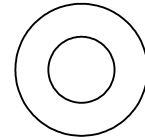

#12  
PG-HW-W003  
5/16" FLAT WASHER  
QTY (24)

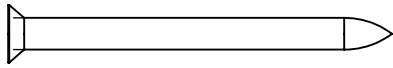

#10  
PG-HW-S004  
#8X2" FLAT HEAD WOOD SCREW  
QTY (10)

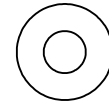

#15  
PG-HW-W001  
#10 FLAT WASHER  
QTY (4)

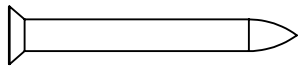

#09  
PG-HW-S003  
#8 X 1.5" FLAT HEAD WOOD SCREW  
QTY (250)

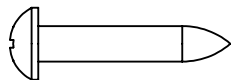

#14  
PG-HW-S001  
#10 X 1" ROUND HEAD SCREW  
QTY (4)

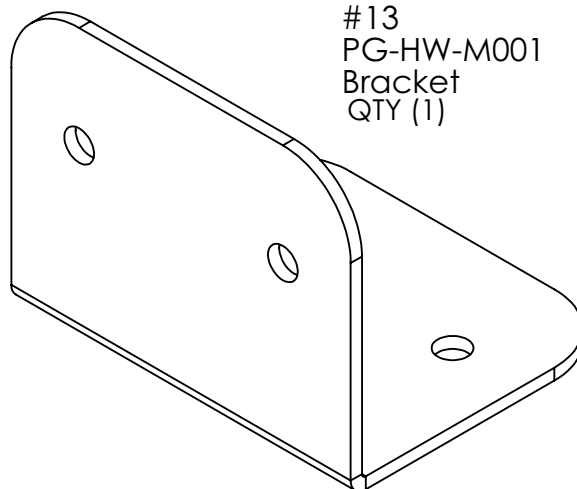

#13  
PG-HW-M001  
Bracket  
QTY (1)

# PARTS IDENTIFICATION

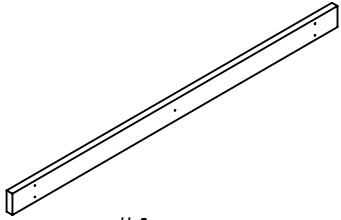

#1  
PG-54-0006  
Picnic Table Board Long  
QTY (2)

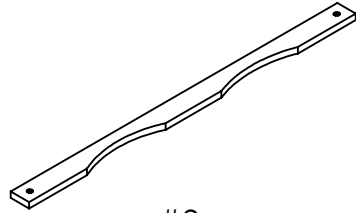

#2  
PG-54-0012  
Enclosure Window Front  
QTY (2)

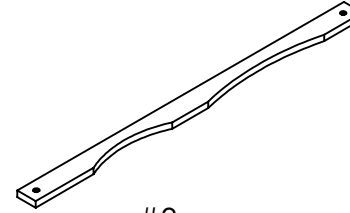

#3  
PG-54-0013  
Enclosure Door Front  
QTY (1)

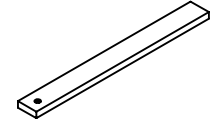

#4  
PG-54-0014  
Enclosure Rail Opened  
QTY (2)

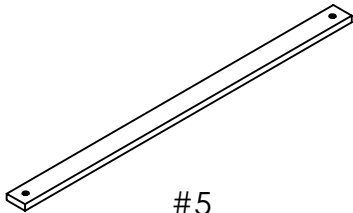

#5  
PG-54-0016  
Enclosure Rail  
QTY (7)

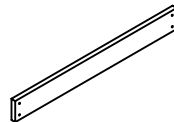

#6  
PG-14-0010  
28 1/2" Enclosure Slat  
QTY (20)

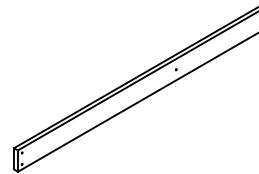

#7  
PG-14-0013  
43 3/4" Enclosure Slat  
QTY (34)



#8  
PG-54-0015  
Enclosure Rail Short  
QTY (2)

# INSTALL FLOOR SUPPORT

**Note: All parts and hardware for this step are from base set kit.**

Remove Corner Braces from playset. Turn them on edge and slide them up in between Fascia Board and Main Beam. Reinstall lag screw removed from Fascia to secure Corner Brace in place.

Install a Safety Rail to the inside of Corner Posts as shown using 5/16" x 3" Lag Bolts and 5/16" Flat Washers. Safety Rail should be 1" below top of Sandbox Sides.

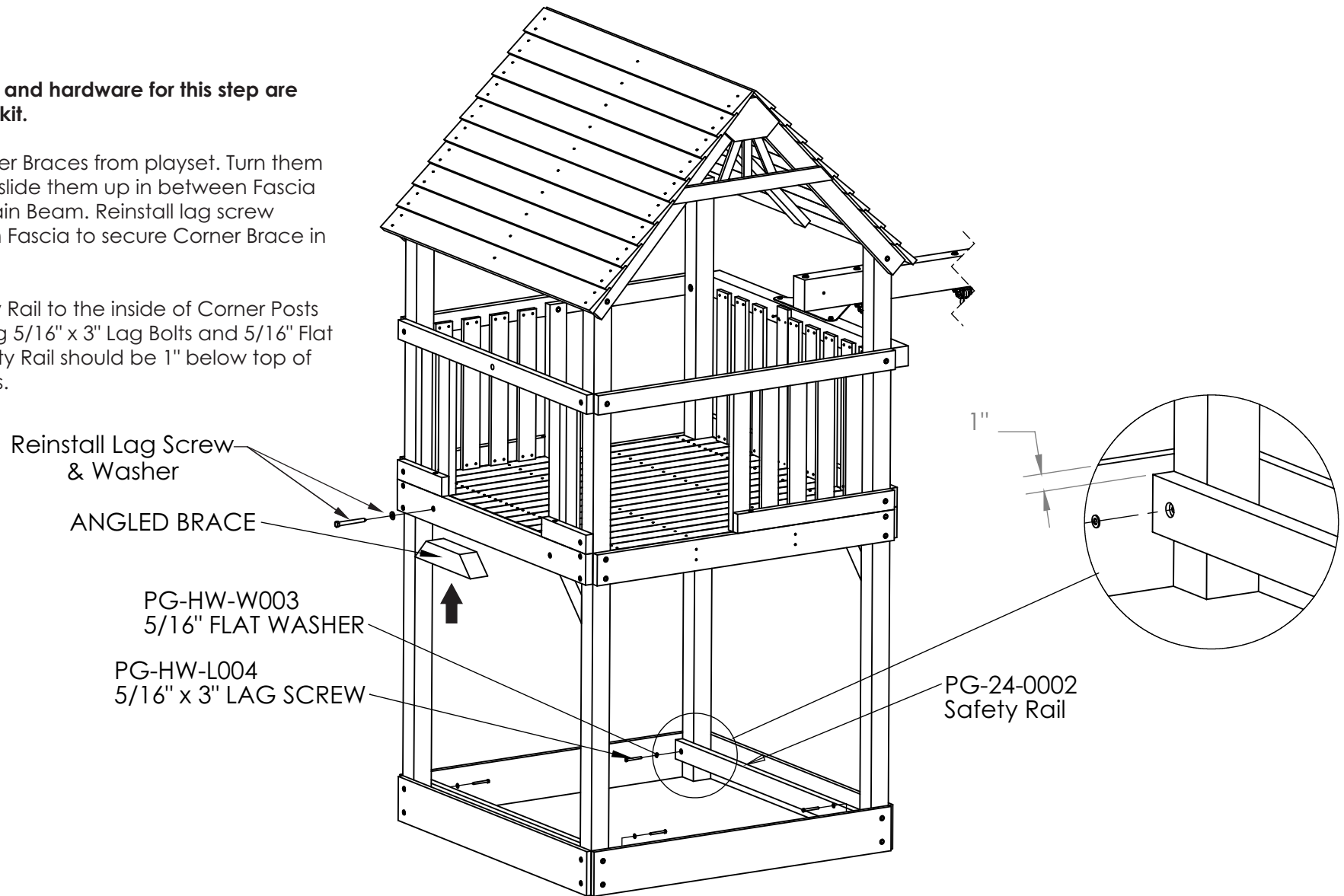

# INSTALL FLOOR

**Note: All parts for this step are from base set kit except 2 Long Picnic Table Boards #1.**

Layout and evenly space 2 Short Picnic Table Boards in between corner posts as shown. Secure using 4 #8 x 2" Flat Head Screws.

Center a Safety Rail under Short Picnic Table Boards as shown and secure using 2 #8 x 2" Flat Head Screws.

Layout and evenly space 15 Long Picnic Table Boards and secure using 75 #8 x 2" Flat Head Screws.

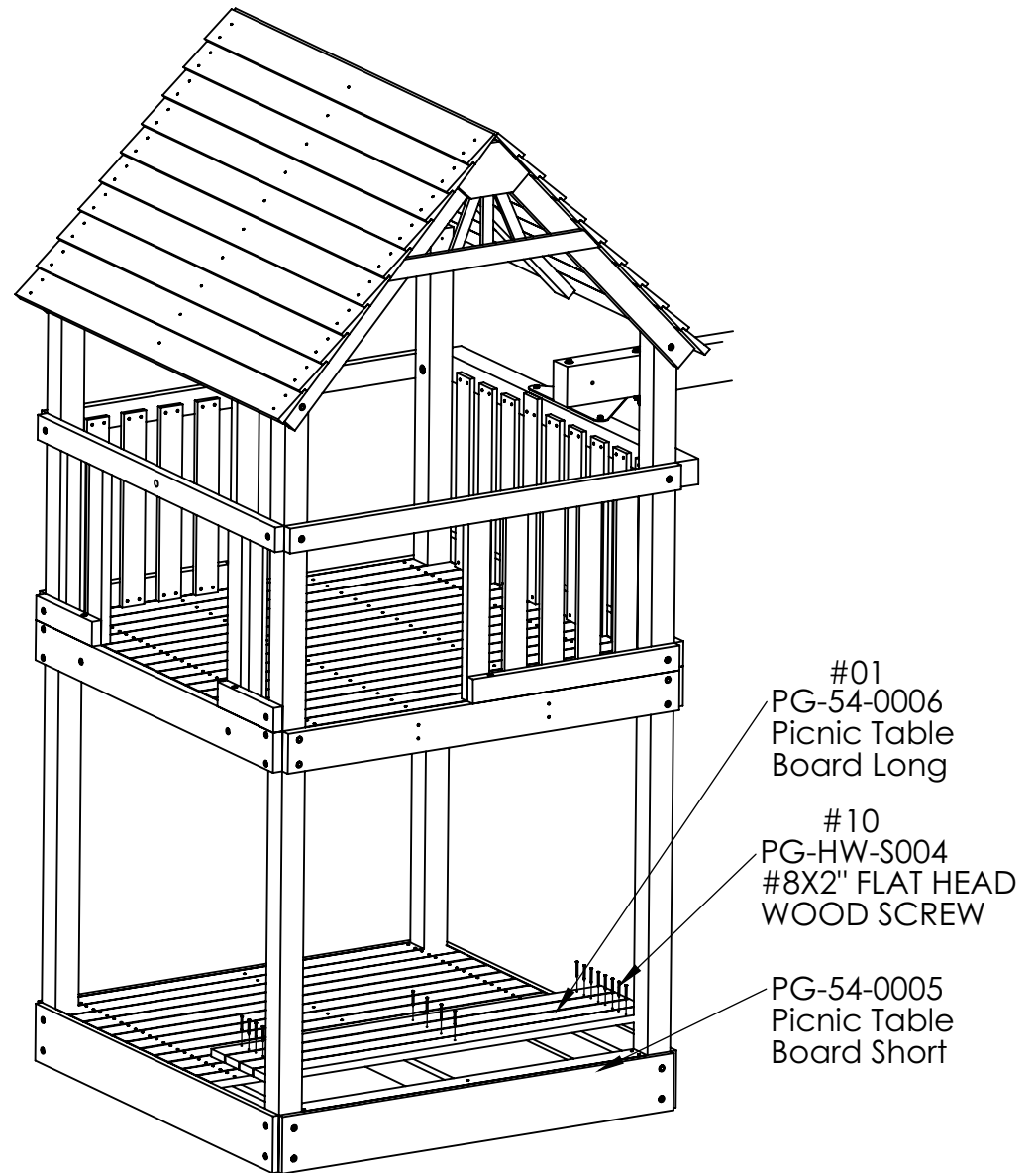
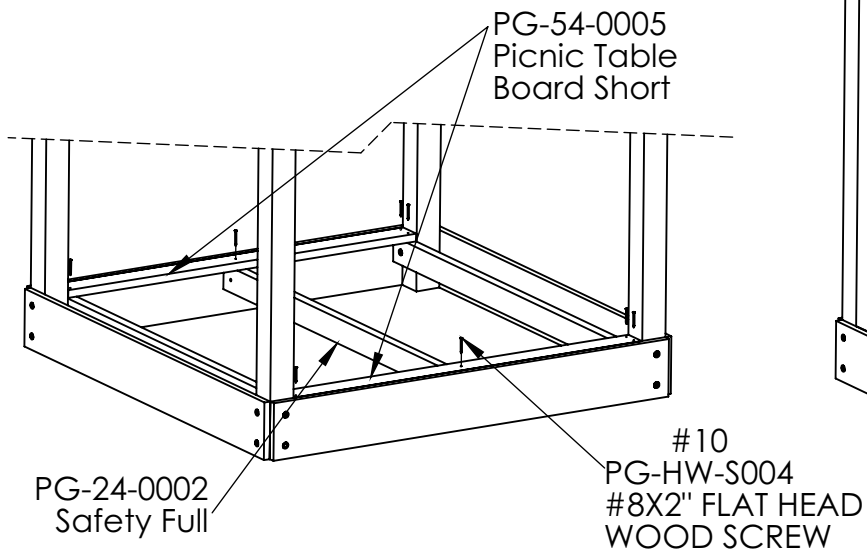

# INSTALL ENCLOSURE RAILS

Secure Enclosure Rails #4, #5 and #8 to Corner Posts using Hardware # 11 and #12. Note Swing Beam side in relation to Enclosure Rail #5.

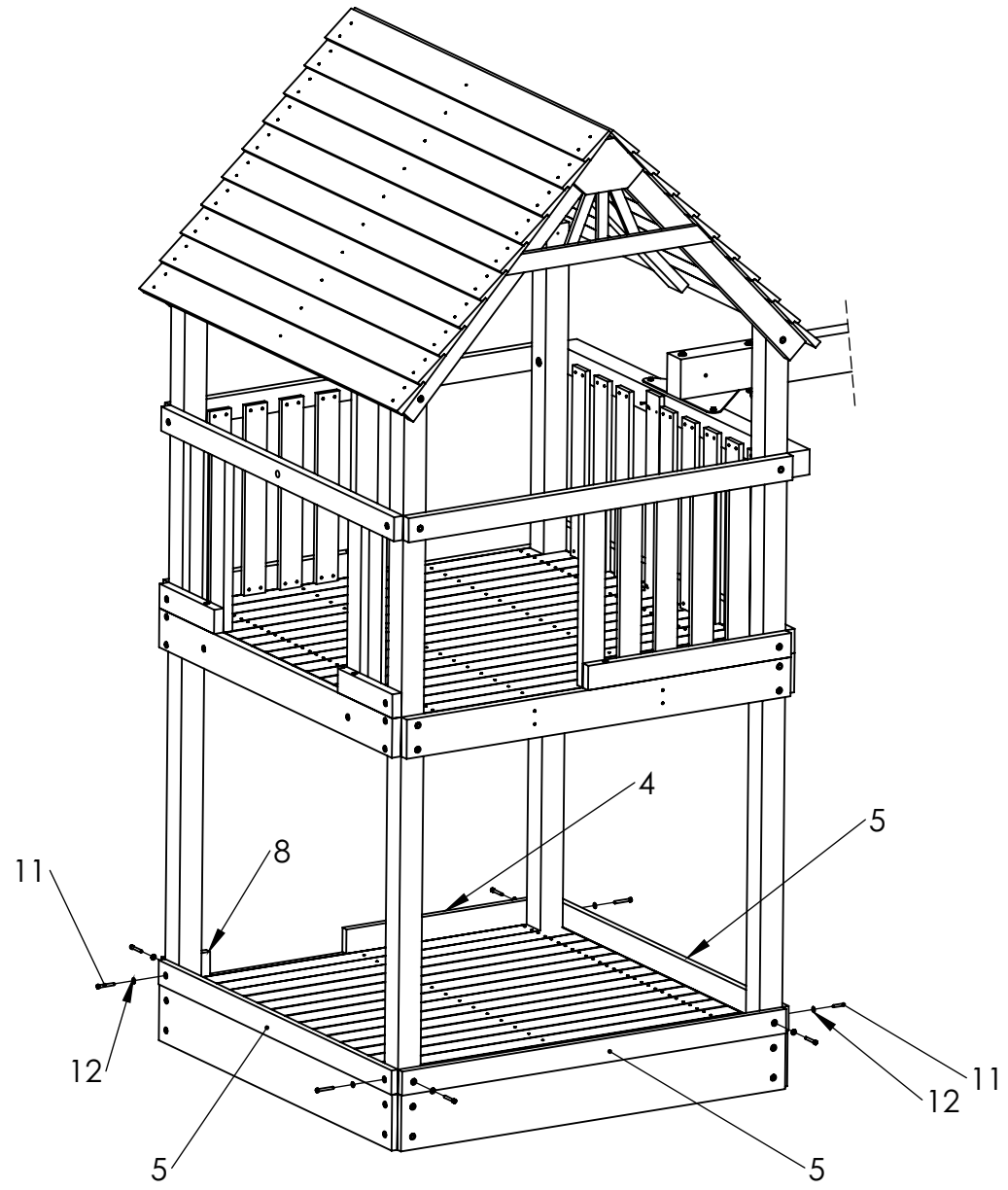

# INSTALL WINDOW & DOOR FRONT

Secure Window Front #2, Door Front #3 and Enclosure Rail #5 to Corner Posts using Hardware #13 and #12. Note Swing Beam side in relation to Enclosure Rail #5 and Door Front #3.

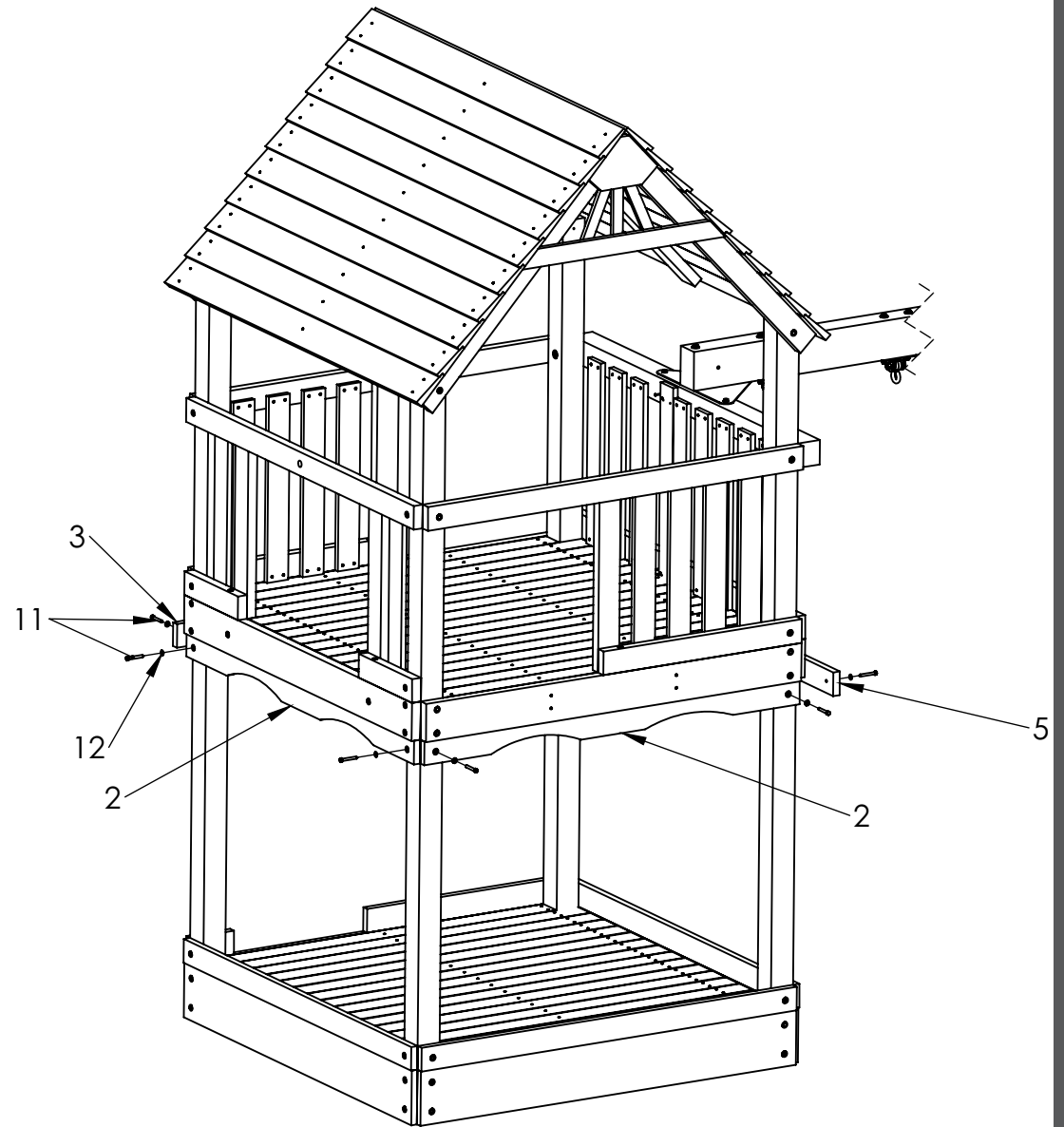



# DOOR OPENING

Secure 43 3/4" Enclosure Slat #7 to Door Front #3 at top and Enclosure Rail #4 at bottom using Hardware #9.

**Note: Door opening should be 24" at top and bottom.**

Make sure Enclosure Rail #4 is flush with front of sandbox side and attach Bracket #13 as shown with hardware #15 and #14.

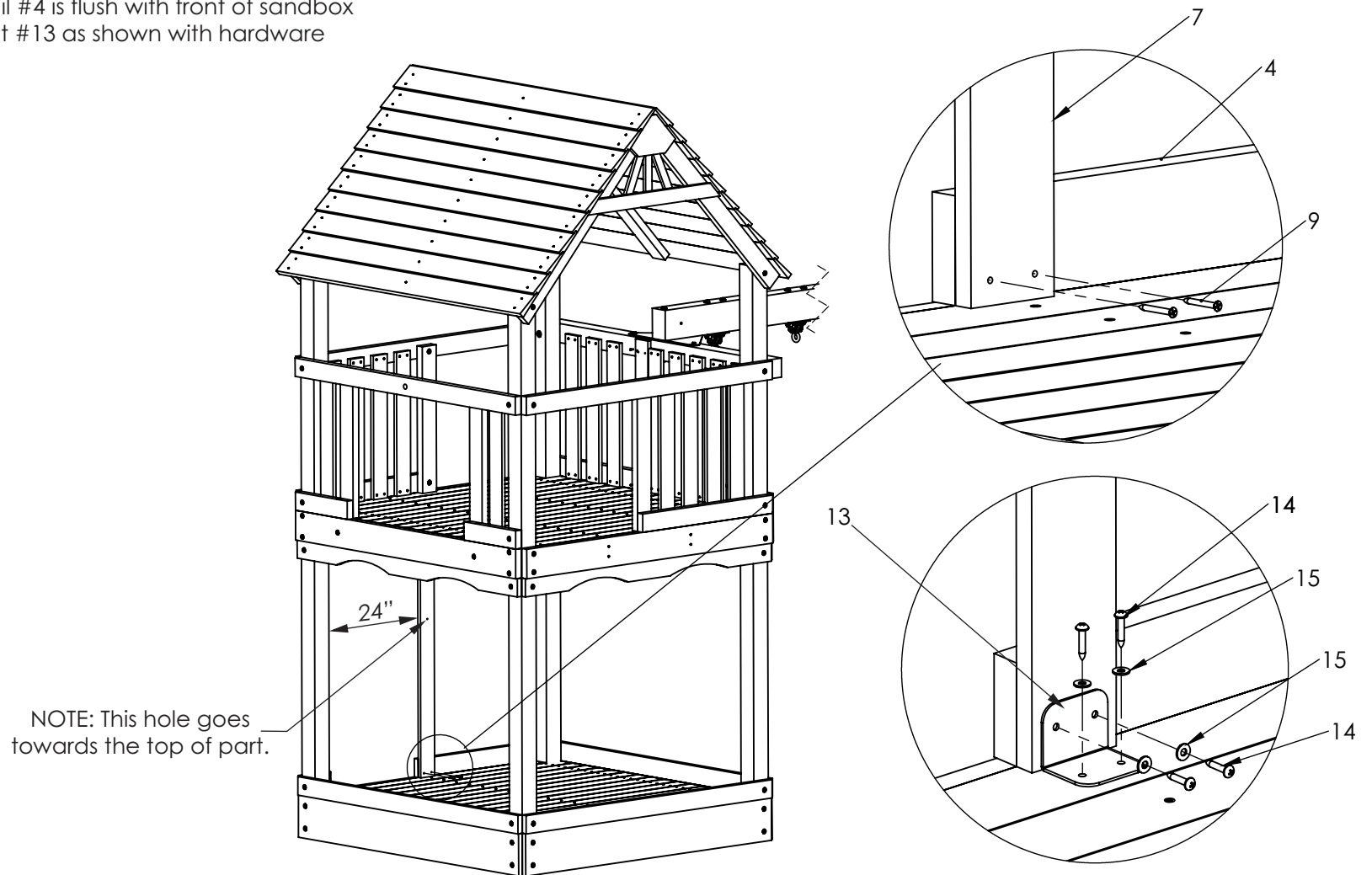

# INSTALL ENCLOSURE RAILS

Attach Enclosure Rails #4, #5 and #8 to Corner Posts as shown using Hardware # 11, #12 and #9. Top of Enclosure Rails should be 26 1/4" from top of previously installed Enclosure Rails.

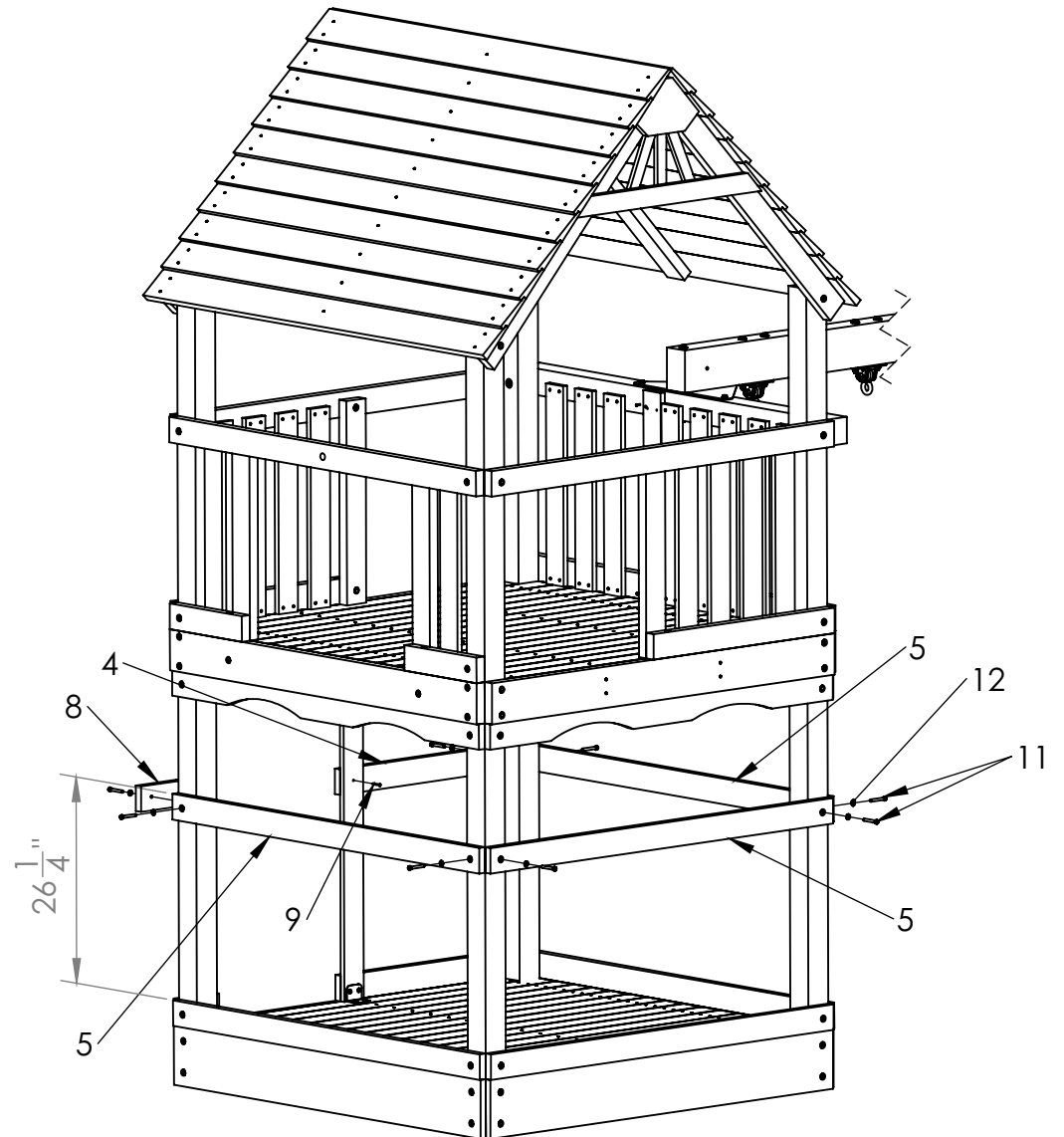

# ENCLOSE BACK

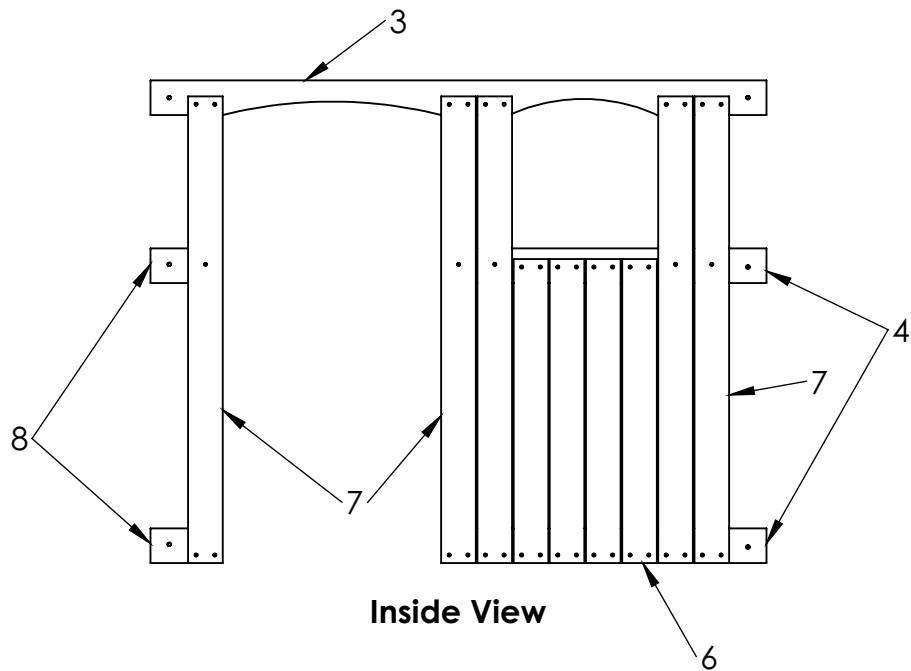

Inside View

**HINT: TO ACHIEVE PROPER SPACING STAND BOARDS UP BEFORE SECURING ANY BOARDS, AND TACK IN PLACE BY STARTING ONE TOP SCREW IN EACH BOARD AS SHOWN .**

Secure Enclosure Slats #6 and #7 from inside set to enclose the back of the playset as shown using hardware #9.

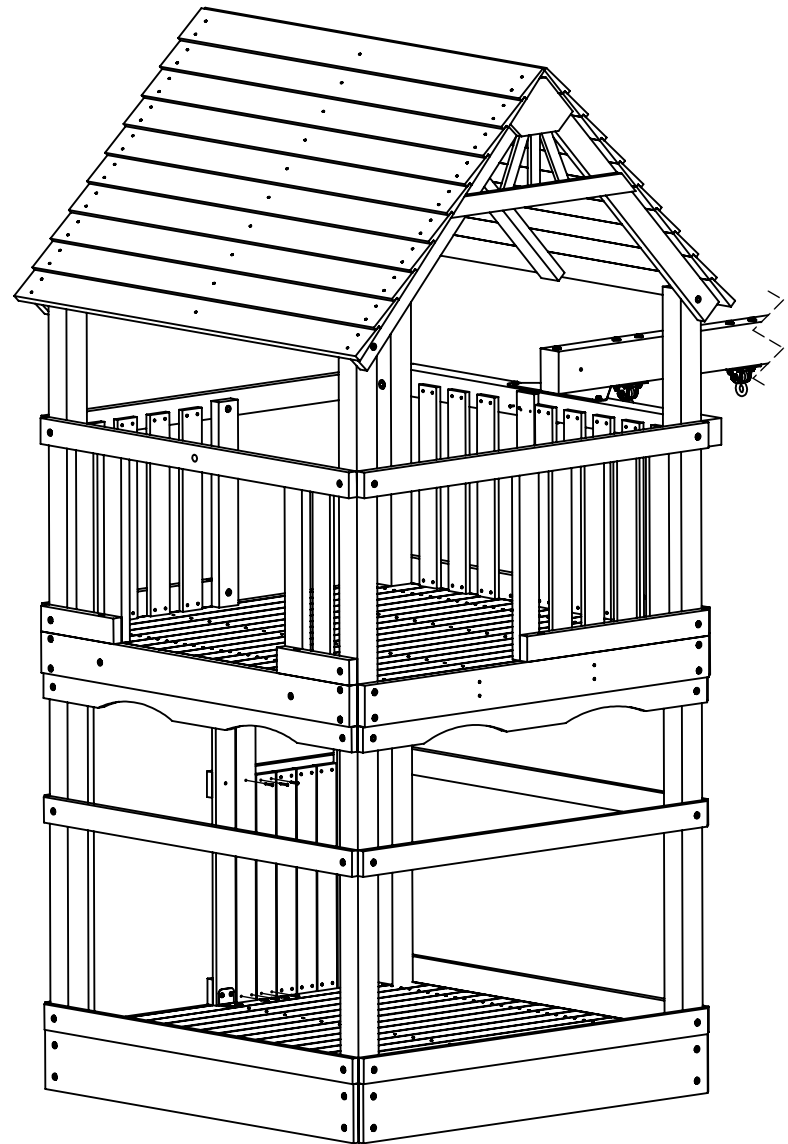

# ENCLOSE SWING BEAM SIDE

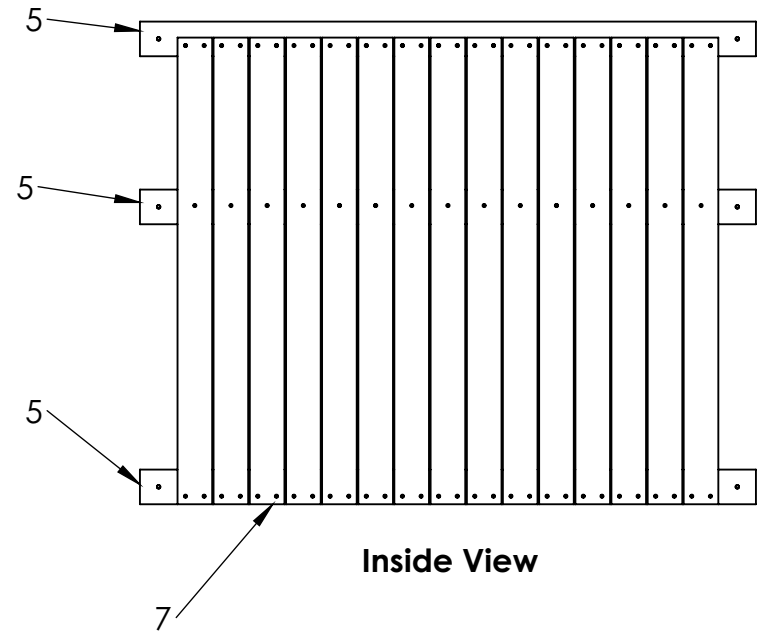
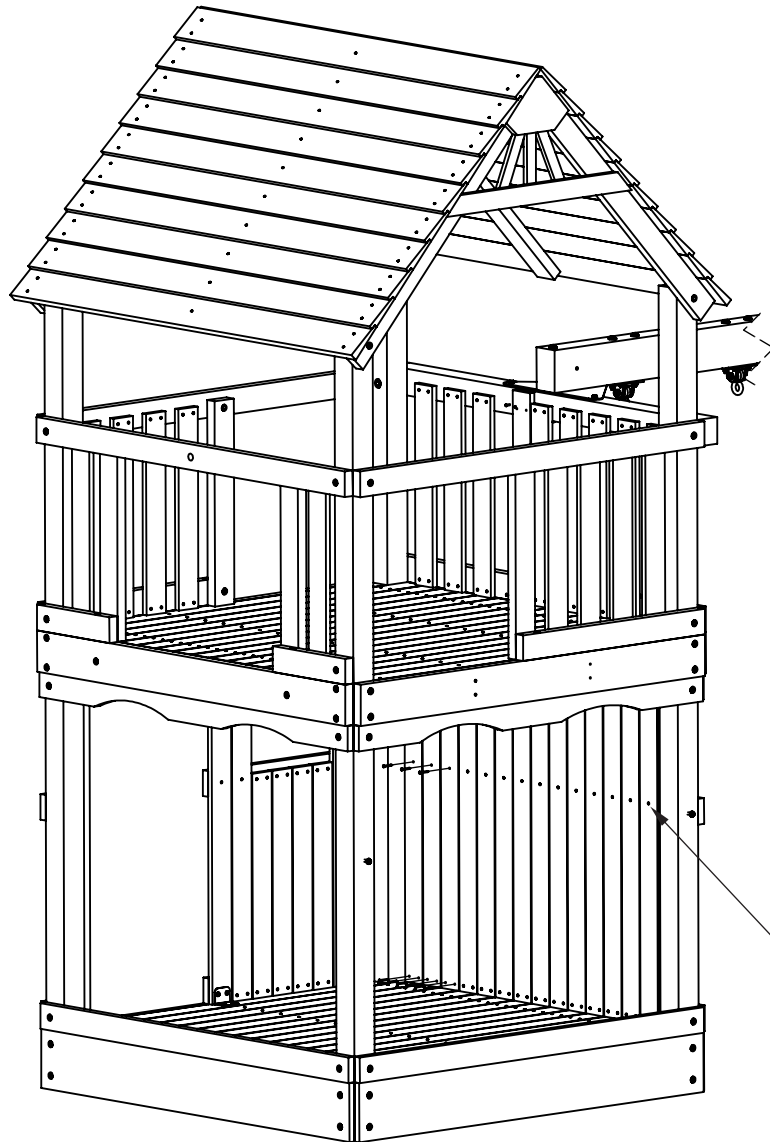

Inside View

**HINT: TO ACHIEVE PROPER SPACING STAND BOARDS UP BEFORE SECURING ANY BOARDS, AND TACK IN PLACE BY STARTING ONE TOP SCREW IN EACH BOARD AS SHOWN .**

Secure Enclosure Slats #7 from inside set to enclose the swing beam side of the playset as shown using hardware #9.

NOTE: This hole goes towards the top of part.

# ENCLOSE FRONT

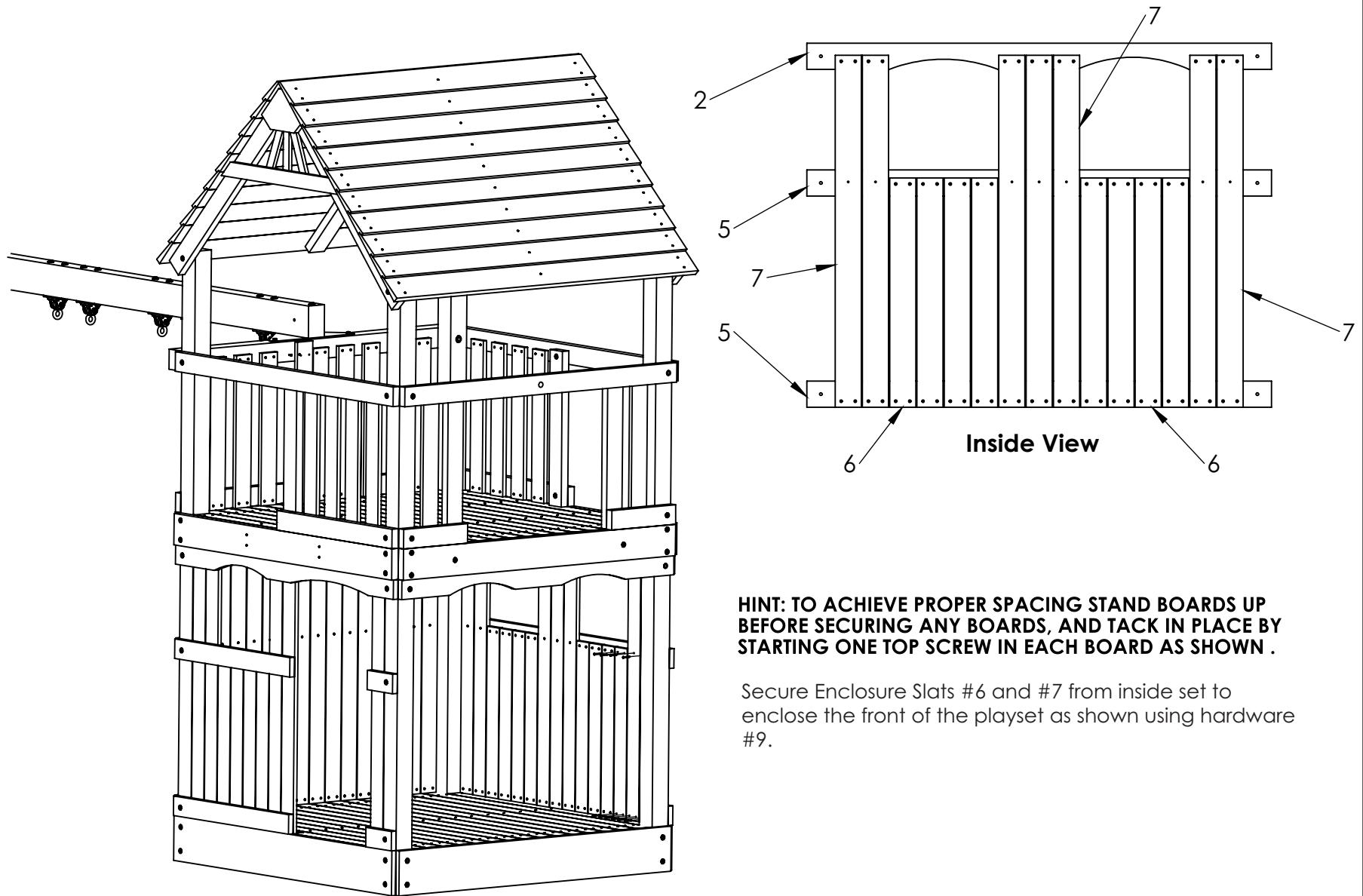

**HINT: TO ACHIEVE PROPER SPACING STAND BOARDS UP BEFORE SECURING ANY BOARDS, AND TACK IN PLACE BY STARTING ONE TOP SCREW IN EACH BOARD AS SHOWN .**

Secure Enclosure Slats #6 and #7 from inside set to enclose the front of the playset as shown using hardware #9.

# ENCLOSE SIDE

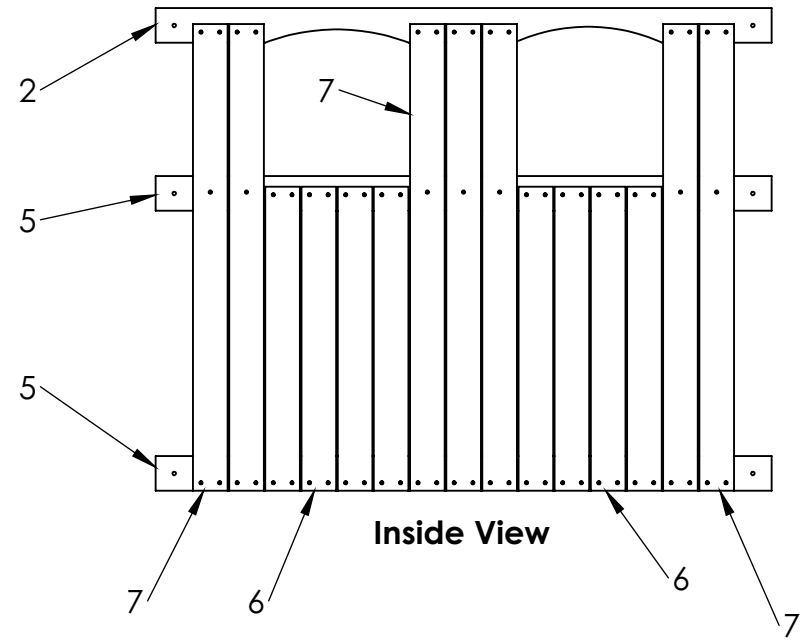
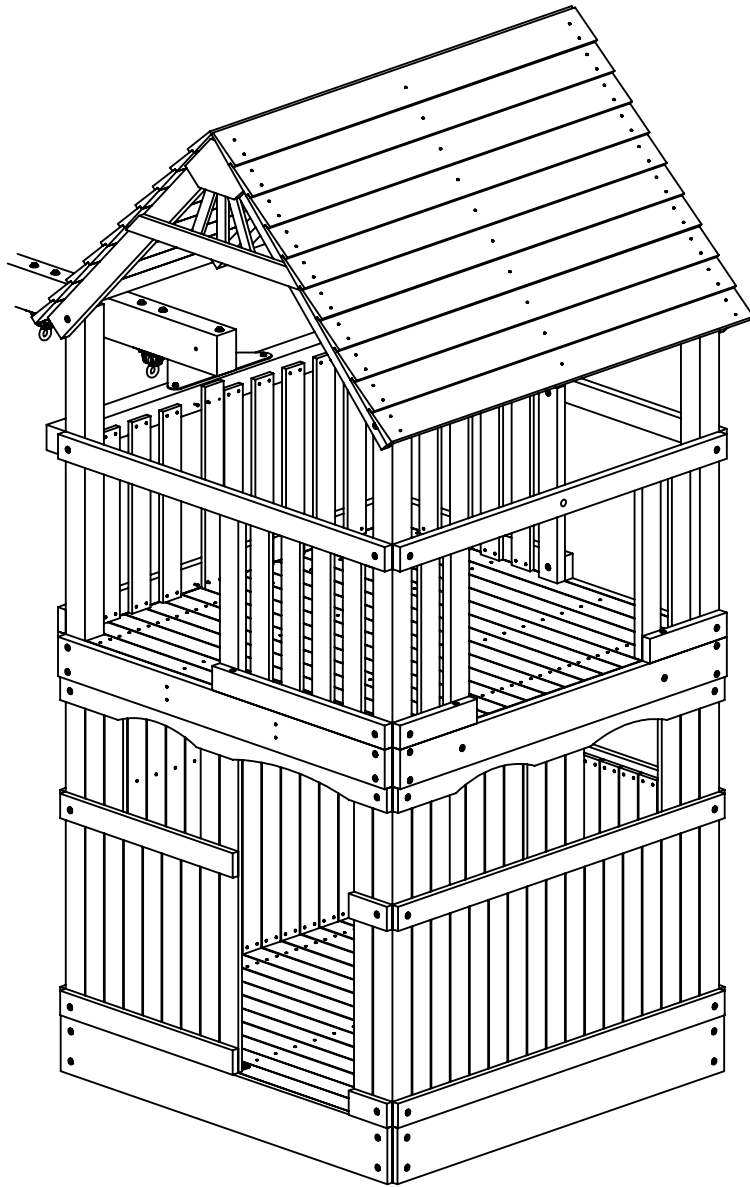

Secure Enclosure Slats #6 and #7 from inside set to enclose the side of the playset as shown using hardware #9.

# ChildLife® Playsets

ChildLife Limited Lifetime  
& TwoYear Warranties

Subject to proper installation and normal residential use, Escalade Sports warrants, subject to the limitations stated below, to the original retail purchaser, all chain, seats, swing hangers, hardware, metal braces, ropes and accessories to be free from defects in material and workmanship for a period of two years from date of purchase. Cracks in non-functional plastic components are not considered defects in materials and workmanship if they do not affect the functionality of the playset. Merchandise covered under this limited two-year warranty will, at our option, be repaired or replaced, excluding **any freight or labor fees that may be required.**

In addition, for the lifetime of the playset, Escalade Sports warrants, to the original retail purchaser, all wooden components against structural failure due to corrosion, wood rot, or insect infestation. **Seasonal checks and surface cracks, knotholes and knots, natural characteristics of all wooden play equipment, not resulting in structural failure, are not covered under this warranty.**

Timber is a natural material which can absorb and release moisture. Although this product is designed to minimize this effect, in certain circumstances some movement or distortion is unavoidable. During dry hot weather timber may shrink and check - this is a normal process of weathering. After the first year of service it is advisable to apply a non-toxic stain / sealant safe for children's use.

Components covered under this limited lifetime warranty will be replaced free of charge excluding freight and labor fees.

**Non-residential use of the playset is prohibited and voids the warranty as the playsets are designed for residential use only.**

Escalade Sports reserves the right to examine photographs and/or physical evidence of merchandise claimed to be defective, and to recover said merchandise, prior to disposition of warranty claims. Merchandise returned to our factory for examination or recovery must be shipped freight prepaid, unless a Return Authorization Number is issued.

No warranty is offered on equipment subjected to abuse, negligence, improper installation, vandalism, acts of God, unauthorized alteration or attachment to equipment other than our own, or improper use, service or repair by customer or any third party. Escalade Sports assumes no responsibility for incidental or consequential damages which may arise from the purchase or use of our equipment. Please supervise your children's play activity and maintain your play equipment periodically.

THIS WARRANTY IS EXPRESSLY IN LIEU OF ALL OTHER WARRANTIES, EXPRESSED OR IMPLIED, INCLUDING WARRANTIES OF MERCHANTABILITY OR FITNESS FOR USE. CHIDLIFE PLAYSETS DOES NOT ASSUME, OR AUTHORIZE ANY PERSON TO ASSUME FOR US, ANY OTHER LIABILITY IN CONNECTION WITH THE SALE OF OUR PRODUCTS.

**For warranty service, contact:**

Childlife Playsets  
Escalade Sports  
P.O. Box 889  
Evansville, IN 47706  
1-800-GO-SWING

Or E-Mail us at: [playgroundcs@escaladesports.com](mailto:playgroundcs@escaladesports.com)

Revised 2014