

SPECIFICATIONS

DESCRIPTION

- 6 positions (OFF, 1, 1 and 2, 2, 2 and 3, 3) share
- R45, R45-SPEX or R45-EX rough required to complete
- Thermostatic/pressure balance coaxial cartridge with check valves
- Trim only

FLOW

- 23 L/min, 6.0 gpm (US) 60psi

STANDARDS

- ASME A112.18.1 / CSA B125.1
- ASSE 1016
- ADA

WARRANTY

- Most products or parts carry "Limited Warranties" against manufacturing defects. For US customers please visit houseofrohl.com/support and for Canadian customers please visit houseofrohl.ca/support for complete product and finish warranty.



3-way Type T/P (thermostatic/pressure balance) coaxial valve trim

MODELS: TVY45

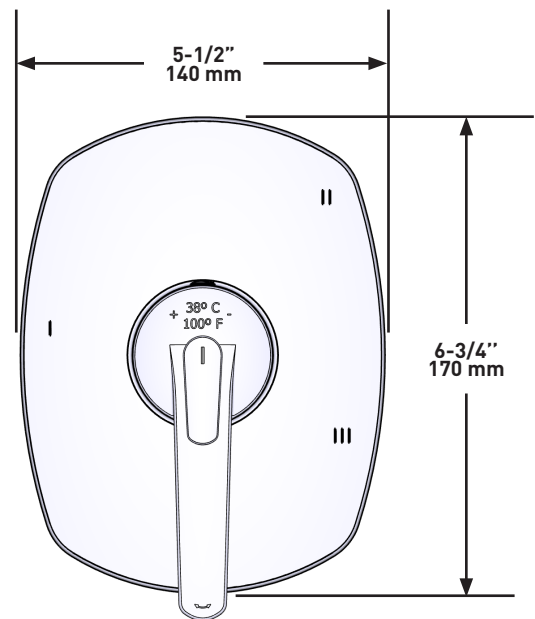
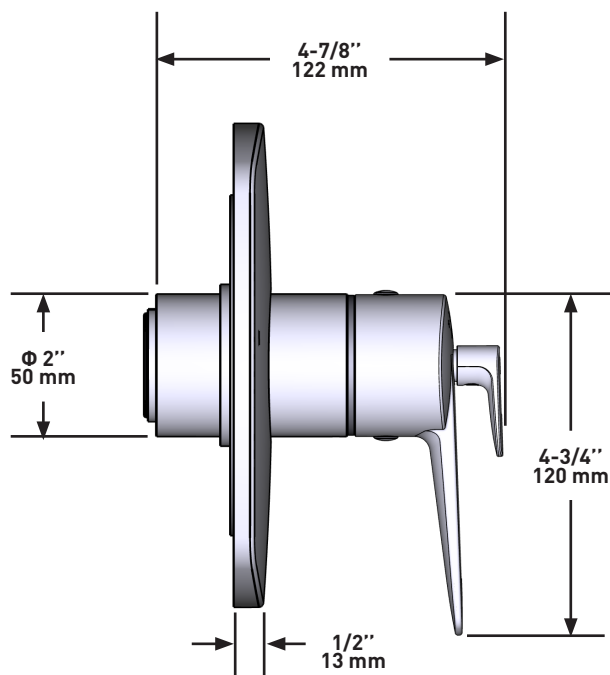

For warranty or additional information, contact:

US Customers

U.S.A.
houseofrohl.com/support
1-800-777-9762

QUEBEC / MARITIMES / WESTERN CANADA
QUÉBEC / MARITIMES / OUEST CANADIEN
QUEBEC / MARITIMOS / CANADA OCCIDENTAL
houseofrohl.ca/support
1-866-473-8442

Canadian Customers

ONTARIO
houseofrohl.ca/support
1-800-287-5354

SPÉCIFICATIONS

DESCRIPTION

- 6 positions (OFF, 1, 1 et 2, 2, 2 et 3, 3) partagées
- Commandez le brut R45, R45-SPEX ou R45-EX pour compléter
- Cartouche thermostatique/pression équilibrée coaxiale avec clapets anti-retour
- Garniture seule

DÉBITS DISPONIBLES

- 23 L/min, 6.0 gpm (US) 60psi

CERTIFICATIONS

- ASME A112.18.1 / CSA B125.1
- ASSE 1016
- ADA

GARANTIE

- La plupart des produits ou pièces comprend des «garanties limitées» contre les défauts de fabrication. Pour les clients des États-Unis : veuillez consulter houseofrohl.com/support; Pour les clients du Canada : veuillez consulter houseofrohl.ca/support pour connaître les conditions complètes de la garantie des produits et finis.



Garniture pour valve 3 voies coaxiale Type T/P (thermostatique/pression équilibrée)

MODÈLES: TVY45

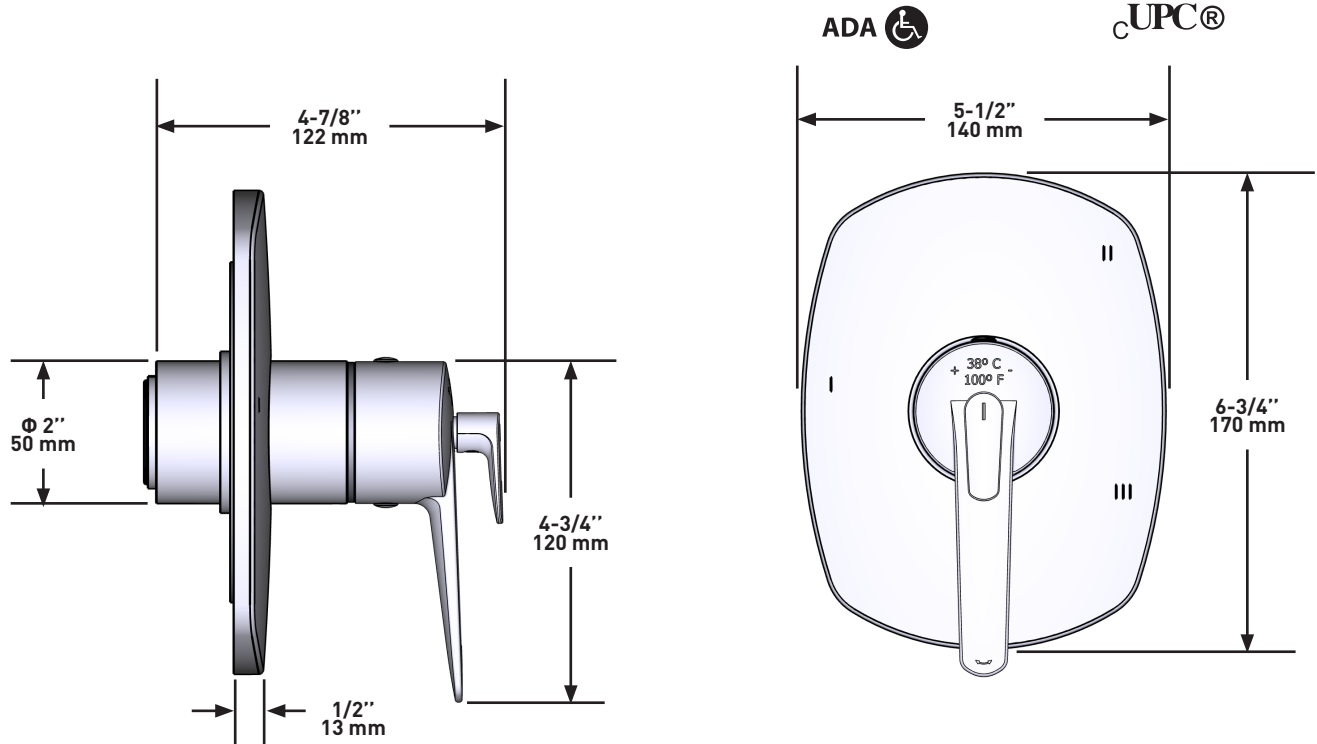

For warranty or additional information, contact:

US Customers

U.S.A.
houseofrohl.com/support
 1-800-777-9762

QUEBEC / MARITIMES / WESTERN CANADA
 QUÉBEC / MARITIMES / OUEST CANADIEN
 QUEBEC / MARITIMOS / CANADA OCCIDENTAL
houseofrohl.ca/support
 1-866-473-8442

Canadian Customers

ONTARIO
houseofrohl.ca/support
 1-800-287-5354

ESPECIFICACIONES

DESCRIPCIÓN

- 6 posiciones (OFF, 1, 1 y 2, 2, 2 y 3, 3) de compartir
- Accesorio básico R45, R45-SPEX o R45-EX requerido para completar instalación
- Cartucho coaxial termostático/de equilibrio de presión con válvulas de retención
- Moldura solamente

FLUJO

- 23 L/min, 6.0 gpm (US) 60psi

ESTÁNDARES

- ASME A112.18.1 / CSA B125.1
- ASSE 1016
- ADA

GARANTÍA

- La mayoría de los productos o piezas cuentan con "Garantías Limitadas" por defectos de fabricación. A los clientes en EE. UU. se les recomienda visitar houseofrohl.com/support y a los clientes en Canadá, houseofrohl.ca/support, para consultar las condiciones completas de la garantía de los productos y acabados.



Internos de válvula coaxial tipo T/P (termostático/equilibrio de presión) 3 vías

MODELOS: TVY45

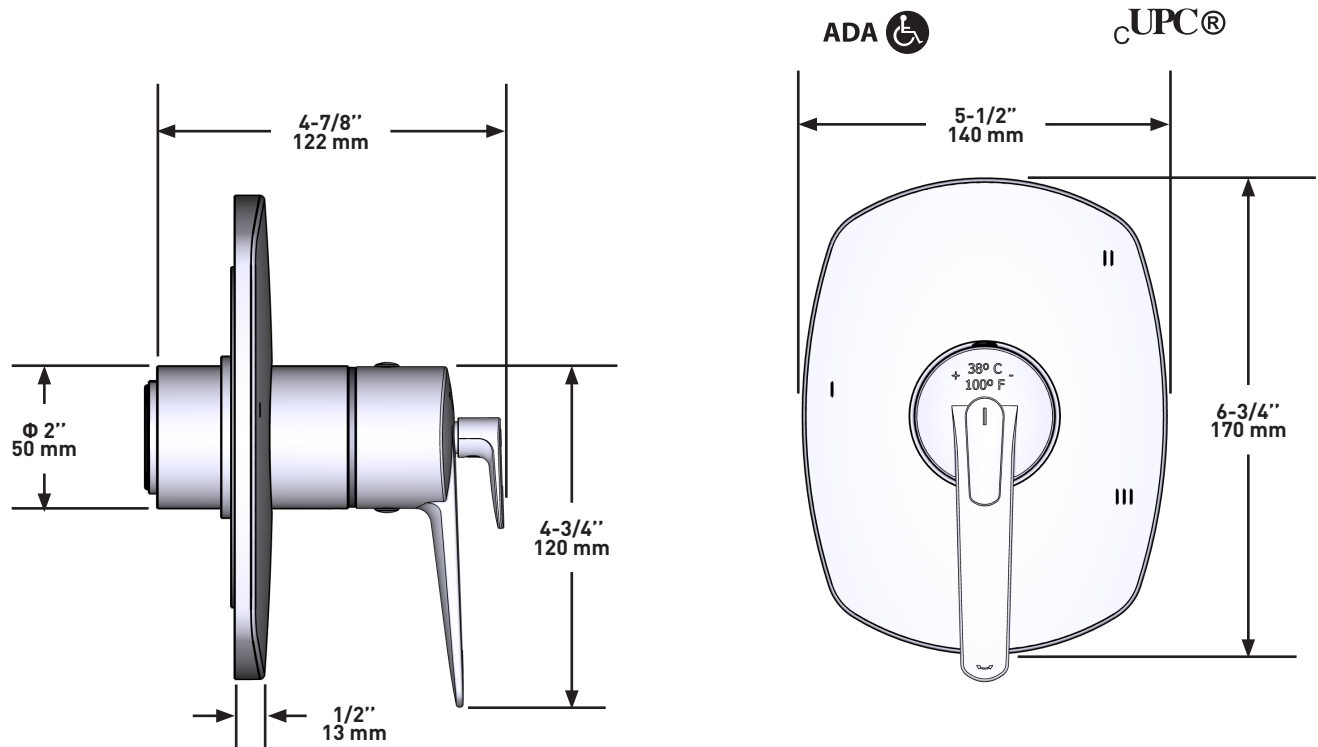

For warranty or additional information, contact:

US Customers

U.S.A.
houseofrohl.com/support
1-800-777-9762

QUEBEC / MARITIMES / WESTERN CANADA
QUÉBEC / MARITIMES / OUEST CANADIEN
QUEBEC / MARITIMOS / CANADA OCCIDENTAL
houseofrohl.ca/support
1-866-473-8442

Canadian Customers

ONTARIO
houseofrohl.ca/support
1-800-287-5354