

**IMPORTANT: BEFORE ASSEMBLING THIS COT, READ AND UNDERSTAND THE INSTRUCTIONS.**

Do not use mattress other than the one supplied by the manufacturer. Incorrect mattress can cause death. Use only accessories as recommended by the manufacturers. Ensure the top rails and base are fully locked. Stop using this cot if any part of the cot is broken, torn or missing.

**KEEP THESE INSTRUCTIONS IN A SAFE PLACE FOR FUTURE REFERENCE.**

11961-AU

**ingenuity™**

**Smart & Simple Travel Cot™**



---

Bassinet

[ingenuitybaby.com](http://ingenuitybaby.com)



# ENGLISH

IMPORTANT! KEEP FOR REFERENCE.

## WARNING

### FALL HAZARD:

- **Playard:**

Discontinue use of the product when infant:

- is able to climb out, OR
- reaches the height of 35 in. (890 mm), OR
- weighs more than 30 lbs. (13.6 kg).

...whichever comes first

- **Bassinet:**

To prevent falls, the bassinet MUST NOT BE USED once a child can sit up.

- **Changing Table:**

- The weight of the changing table is 25 lbs. (11 kg).
- ALWAYS stay within arm's reach of your child when using the changing table.
- NEVER leave child unattended.
- ALWAYS use the harness when using the changing table.
- ALWAYS properly secure the changing table to the playard rails.
- DO NOT use the changing table as a sleeping or play area.

### **Failure to follow these warnings and the instructions could result in serious injury or death.**

- Always provide the supervision necessary for the continued safety of your child. When used for playing, never leave the child unattended.
- Only use the product with one child at a time.
- To reduce the risk of SIDS, pediatricians recommend healthy infants be placed on their back to sleep, unless otherwise advised by your physician.
- This product, including the side rails, must be fully erected prior to use. Make sure latches are secure.
- Never leave child in product with the side lowered. Be sure side is in raised and locked position whenever child is in product.
- Keep children away while assembling/disassembling the cot.
- PINCHING HAZARD: Do not place fingers near corners when folding/unfolding cot.
- Product shall not be used without the mattress provided with the product.
- USE ONLY THE MATTRESS SUPPLIED BY THE MANUFACTURER. INCORRECT MATTRESS CAN CAUSE DEATH.
- Do not use a sheet designed to fit a full-size crib. If a sheet is used with the pad, only use one specifically designed to fit this mattress. Do not use the bassinet if you cannot exactly follow these instructions.
- DO NOT modify playard or add any attachments that are not listed in the instruction guide.
- Keep carrying bag away from children.
- For indoor use only.

- NEVER PLACE CHILD IN THE COT WHEN THE BASSINET OR CHANGING TABLE ARE IN PLACE.
- Child can become entrapped and die when improvised netting or covers are placed on top of a product. Never add such items to confine child in the playard.
- DO NOT leave anything on the folding cot (such as toys) that provide a foothold for the child.
- DO NOT use the folding cot near naked heat sources, bar heaters, open fires, or exposed flames.
- Keep the folding cot clear of trailing cables and hanging cords. NEVER place product near a window where cords from blinds or drapes can strangle a child.
- Keep medication and small items that a child could choke on, away from the cot.
- DO NOT use the product if any part of the product, including the rails, has been bitten through by the child.
- Use only accessories as recommended by the manufacturer.

## IMPORTANT

- Adult assembly required.
- Care should be taken in unpacking and assembly.
- Examine product frequently for damaged, missing, or loose parts.
- DO NOT use if any parts are missing, damaged, or broken.
- Contact Kids II for replacement parts and instructions if needed. Never substitute parts.
- Check this product for damaged hardware, loose joints, missing parts, or sharp edges before assembly and periodically during use.

## Battery Information

The electronic unit requires (3) size AA/LR6 (1.5V) alkaline batteries (not included).

 **CAUTION:** Follow the battery guidelines in this section. Otherwise, battery life may be shortened or the batteries may leak or rupture.

- Always keep batteries away from children.
  - Do not mix old and new batteries.
  - Do not mix alkaline, standard, or rechargeable batteries.
  - Only batteries of the same or equivalent type as recommended are to be used.
  - Install the batteries so that the polarity of each one matches the markings in the battery compartment.
  - Do not short-circuit the batteries.
  - Do not store batteries in areas that have extreme temperatures (such as attics, garages, or automobiles).
  - Remove exhausted batteries from the battery compartment.
  - Never attempt to recharge a battery unless it is specifically marked "rechargeable."
  - Rechargeable batteries are to be removed from the toy before being charged.
  - Rechargeable batteries are only to be charged under adult supervision.
  - Do not use rechargeable alkaline batteries in a Ni-Cad or Ni-MH battery charger.
  - Please use the correct disposal method for batteries.
  - Remove batteries before putting the product into storage for a prolonged period of time.
- Weak batteries cause erratic product operation, including distorted sound, dimming or failed lights, and slow or non-working motorized parts. Because each electrical component requires a different operating voltage, replace the batteries when any function fails to operate.
- Do not dispose of product or batteries in fire, batteries may explode or leak.

 This symbol indicates that the product is not to be disposed of in household waste as batteries contain substances that can be damaging to the environment and health. Contact local authority for recycling & collection information.

## Care and Cleaning

- **Mattress and Changing Table:** Remove structural boards. Fasten all hook-and-loop tabs. Fasten buckles. Machine wash in cold water, gentle cycle. Air dry flat. No bleach. Spot clean with a soft, clean cloth and mild soap.
- **Bassinet:** Remove from frame. Machine wash in cold water, gentle cycle. Air dry flat. No bleach. Spot clean with a soft, clean cloth and mild soap.
- **Carrying bag:** Machine wash in cold water on delicate cycle. Air dry. No bleach. Spot clean with a soft, clean cloth and mild soap.

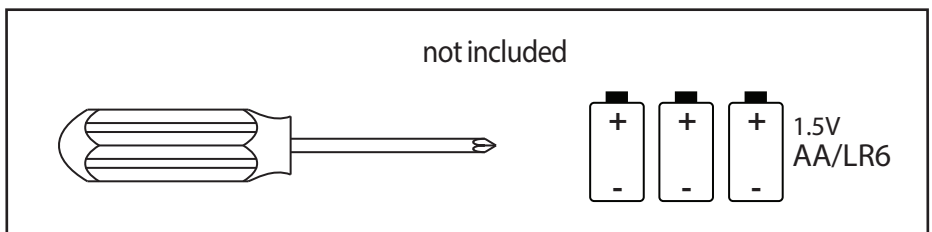

## Parts List and Drawing

Part	Qty.	Description
1	(1)	Carrying Bag
2	(1)	Travel Cot Assembly
3	(1)	Mattress for Travel Cot
4	(1)	Bassinet
5	(2)	Bassinet support tube with coupling
6	(2)	Bassinet support tube
7	(1)	Changing Table, left
8	(1)	Changing Table, right
9	(1)	Changing Table Cover
10	(1)	Music and night light unit

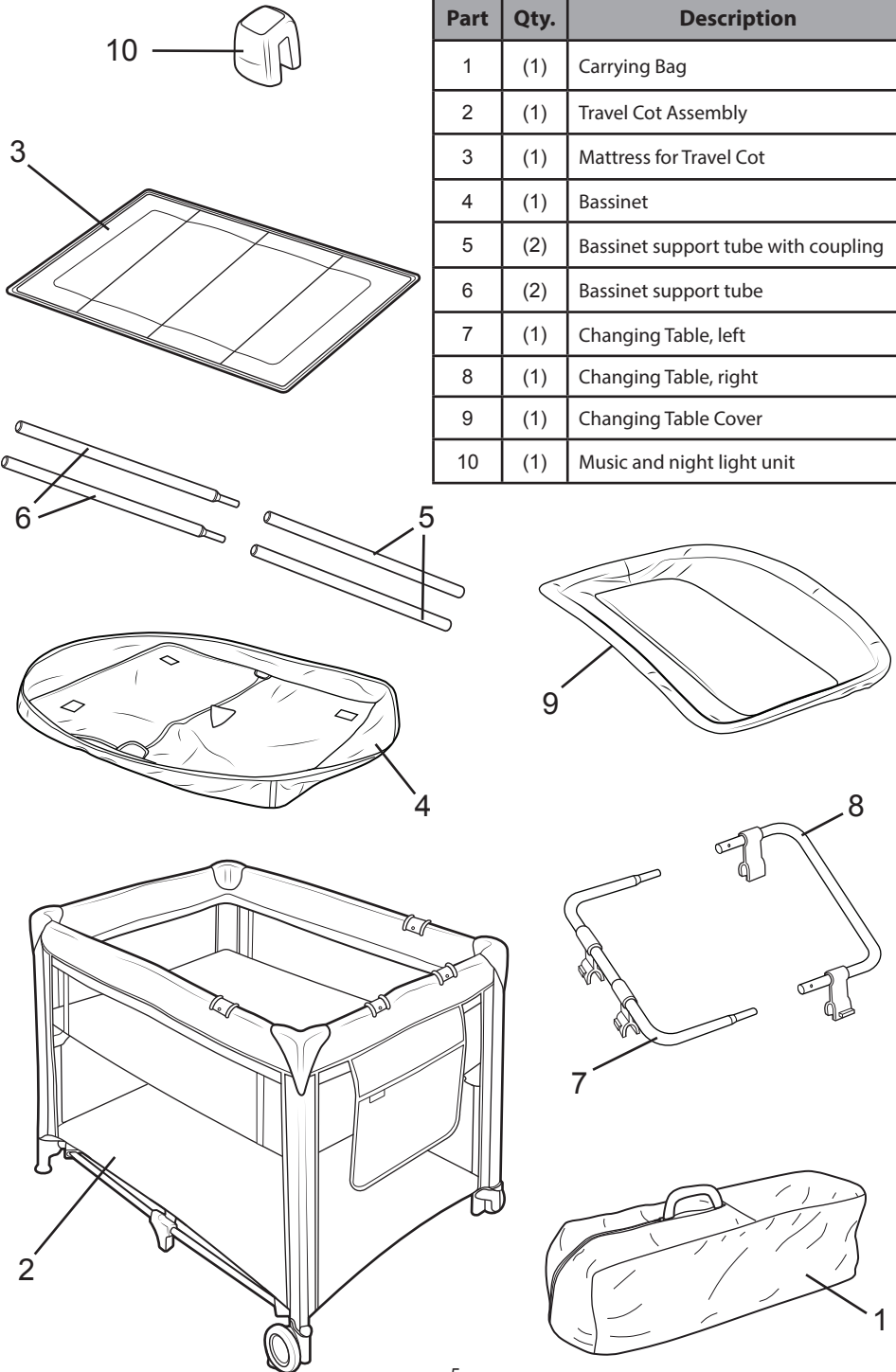

1

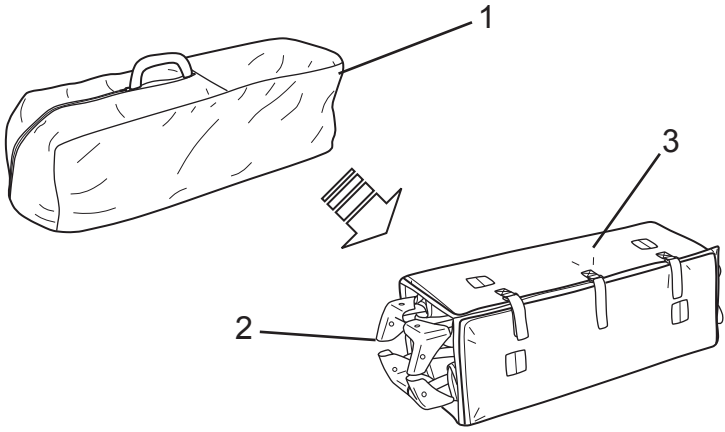

2

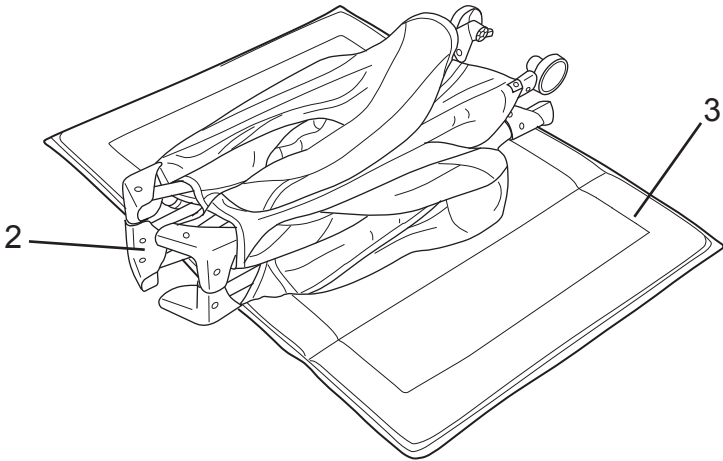

3

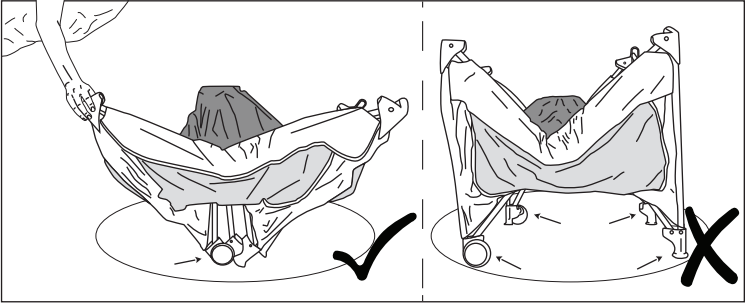

4

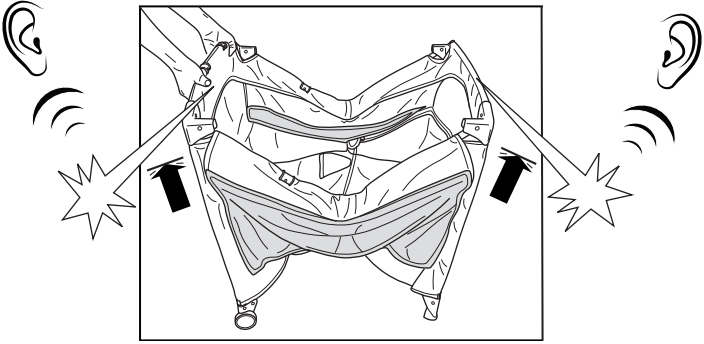

5

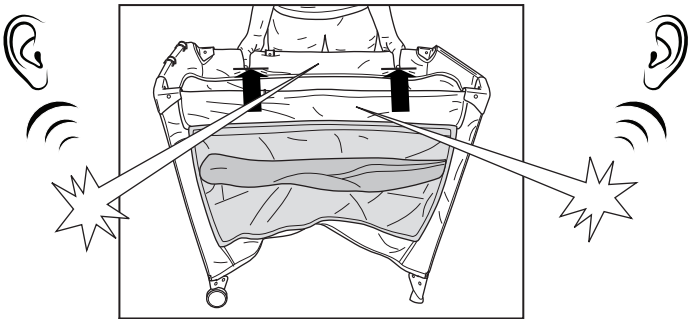

6

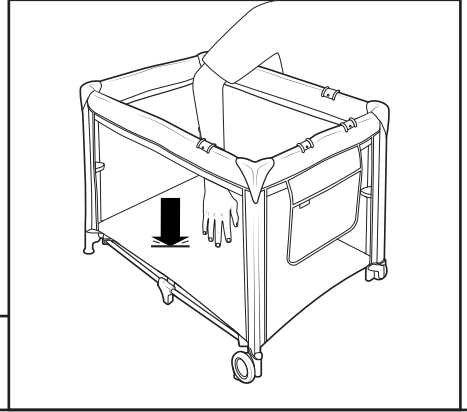

7

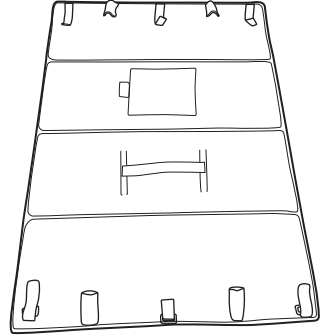
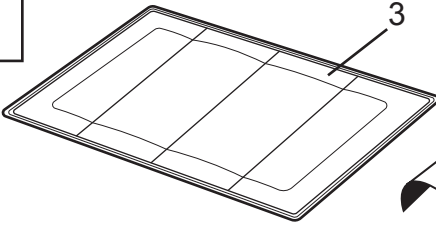

8

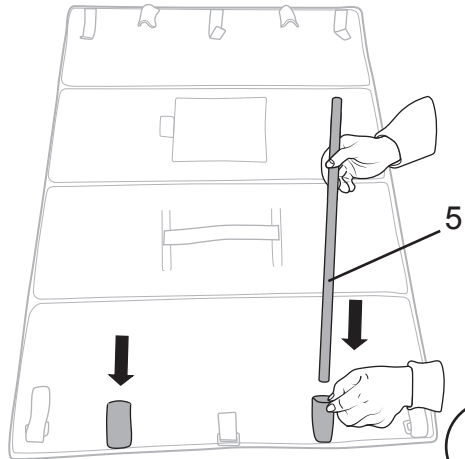
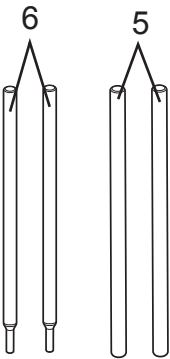

x2



9

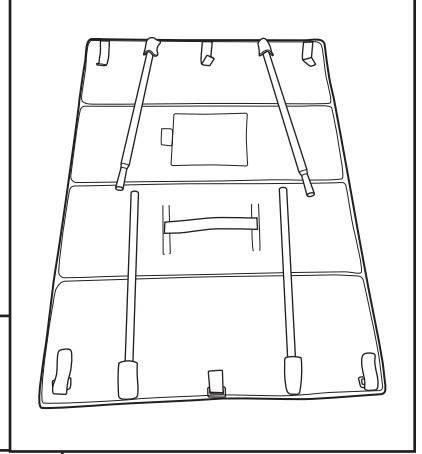
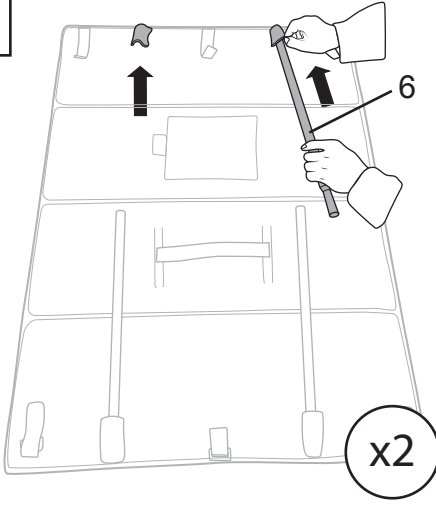

10

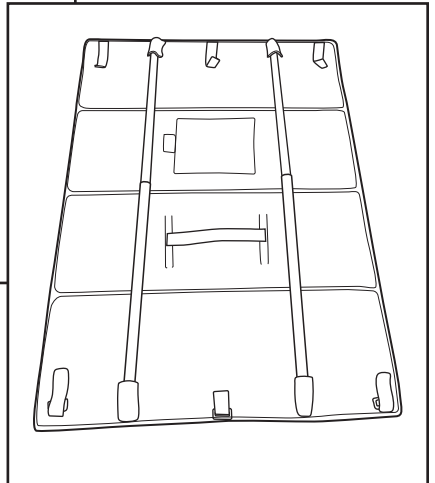
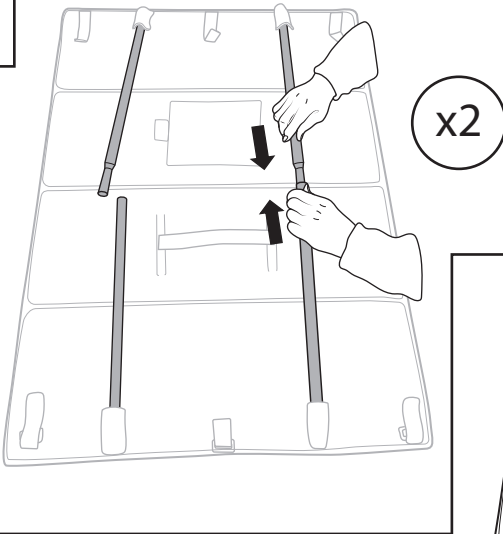

11

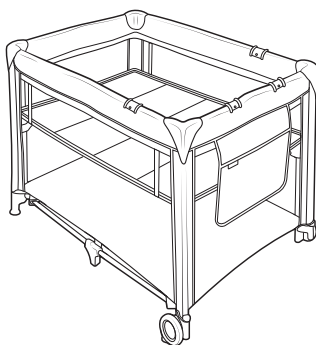
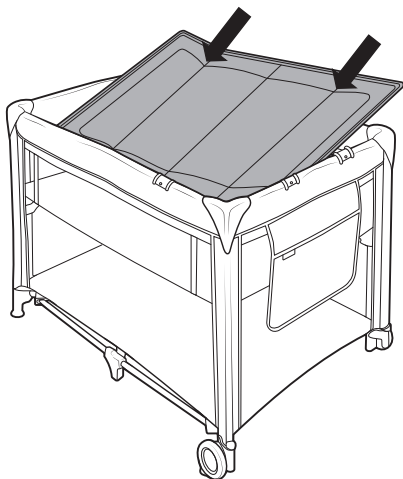

12

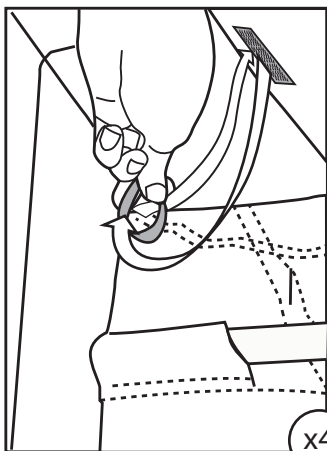
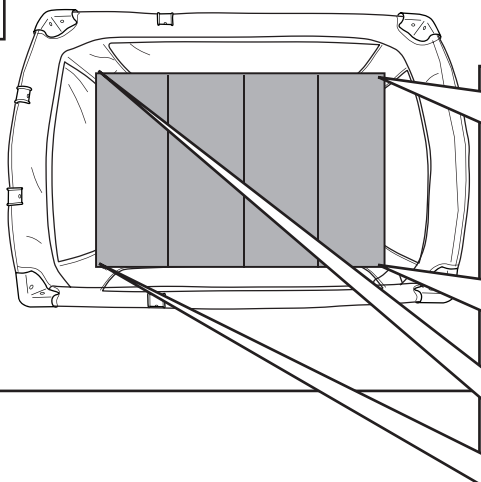

13

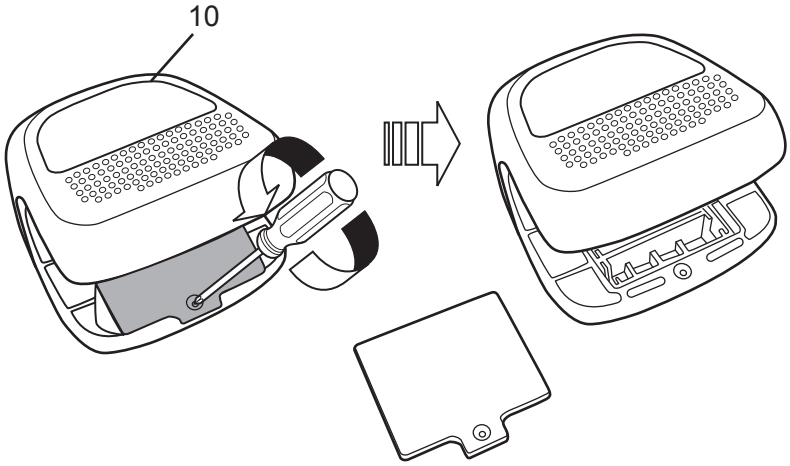

14

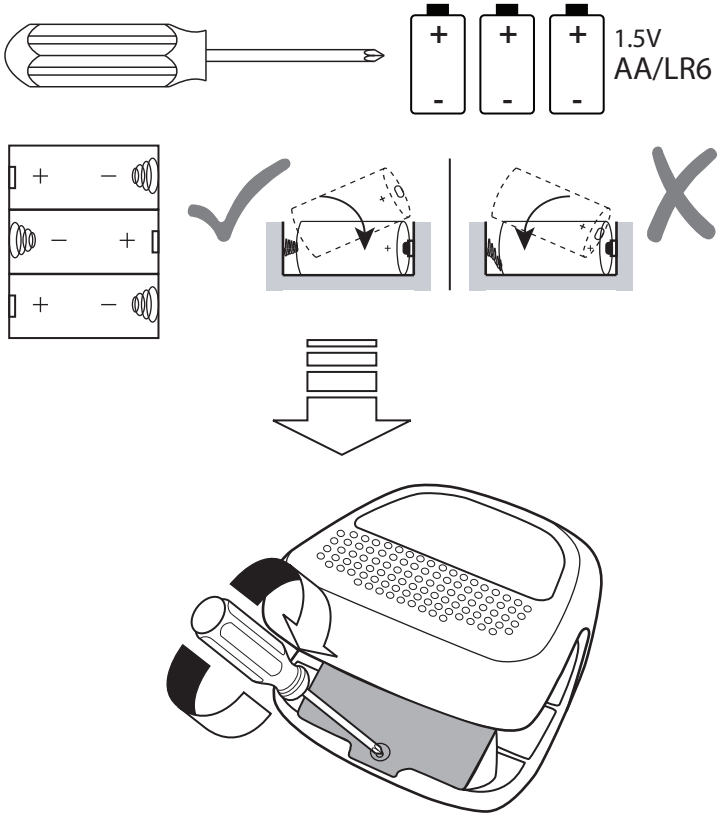

15

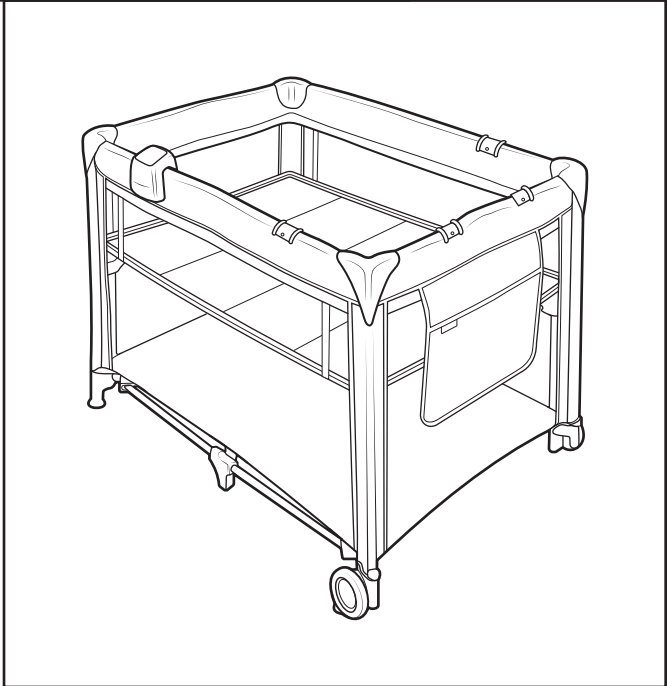
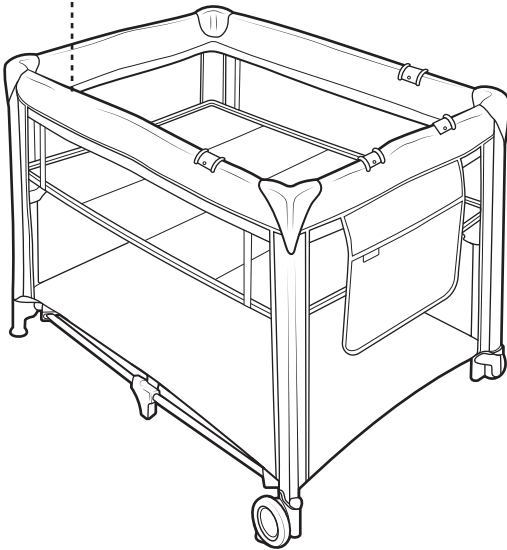
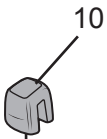

# Changing Table Assembly

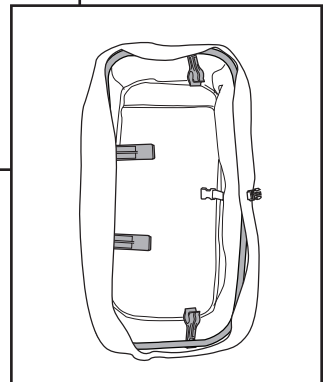
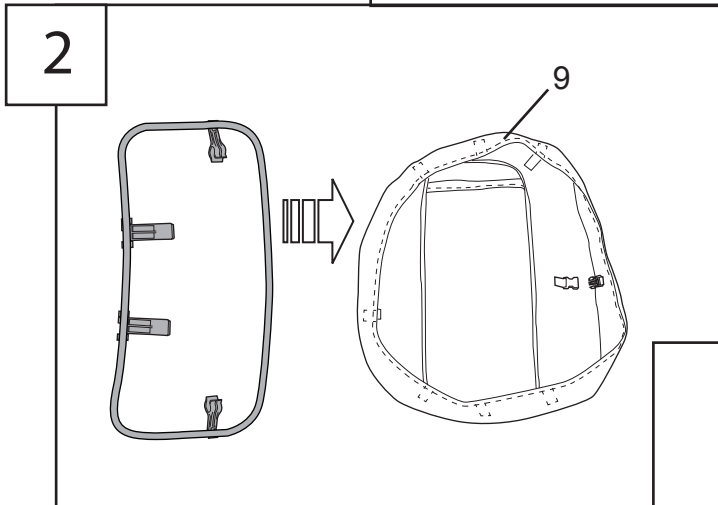
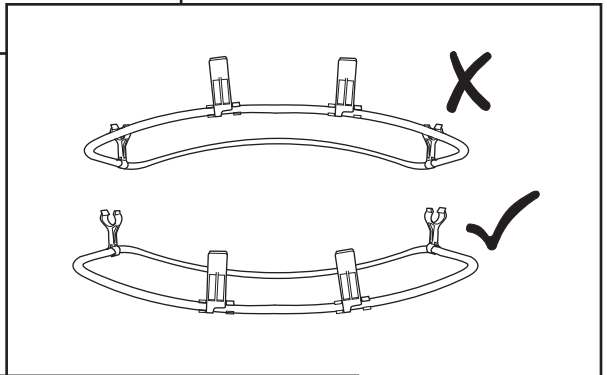
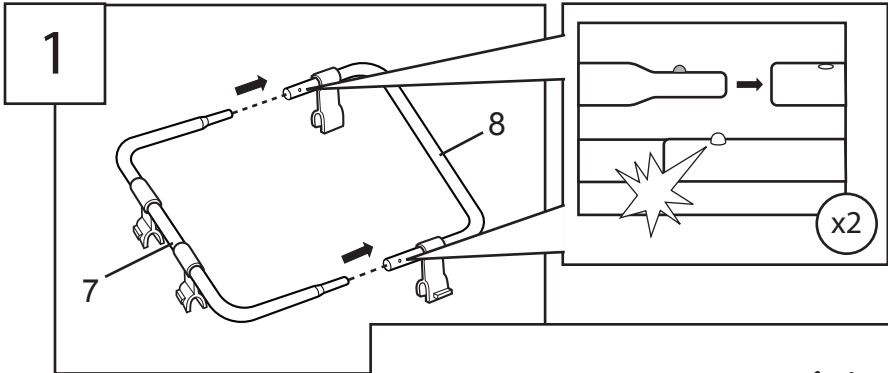

3

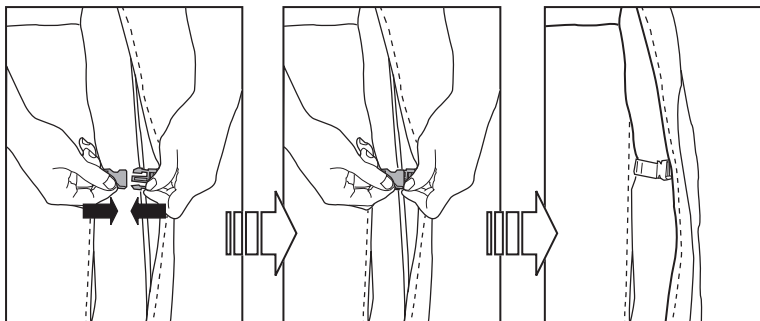

4

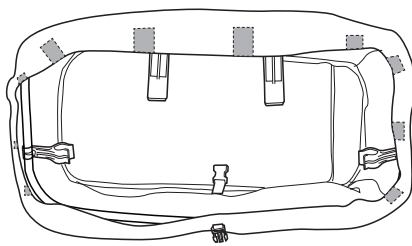
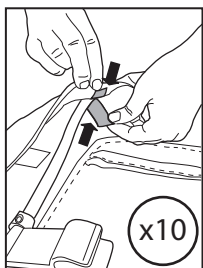

5

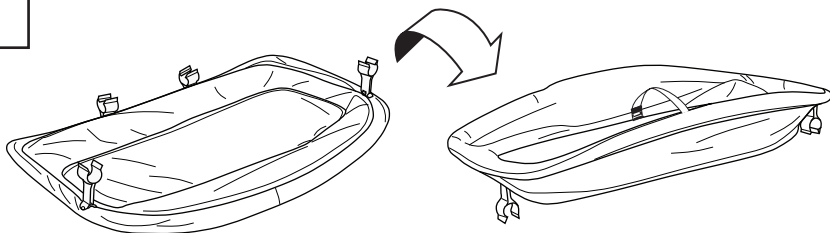

6

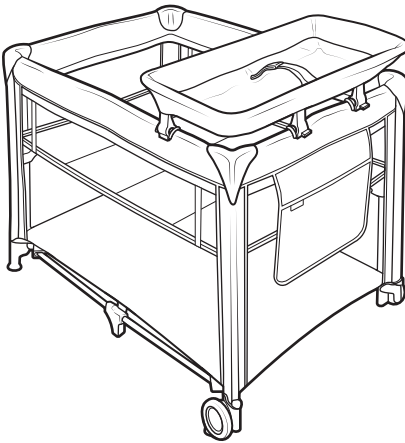
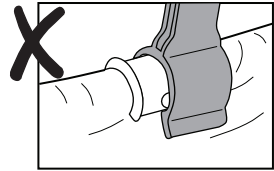
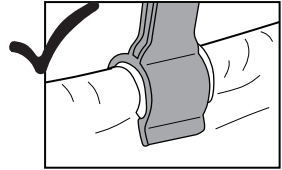
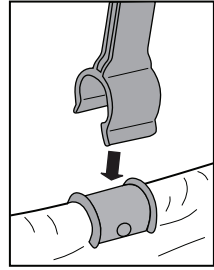
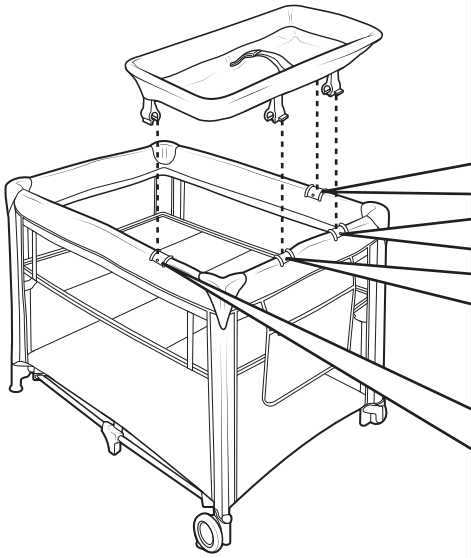

7

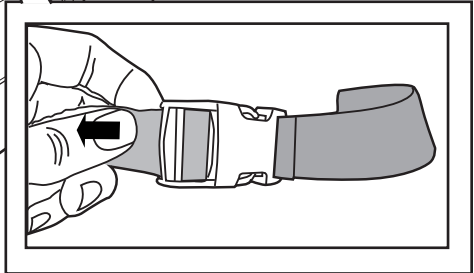
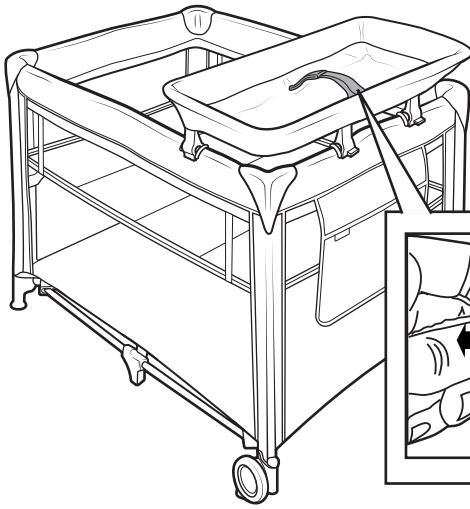

## Changing Table Storage

1

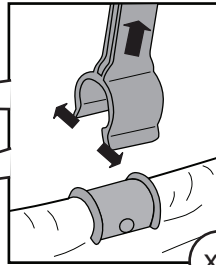
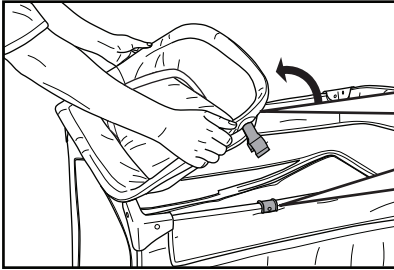

x2

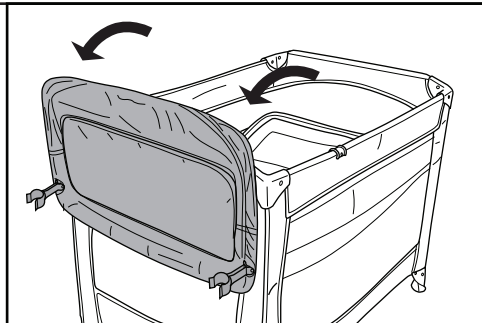



## Using the Music and Night Light Unit

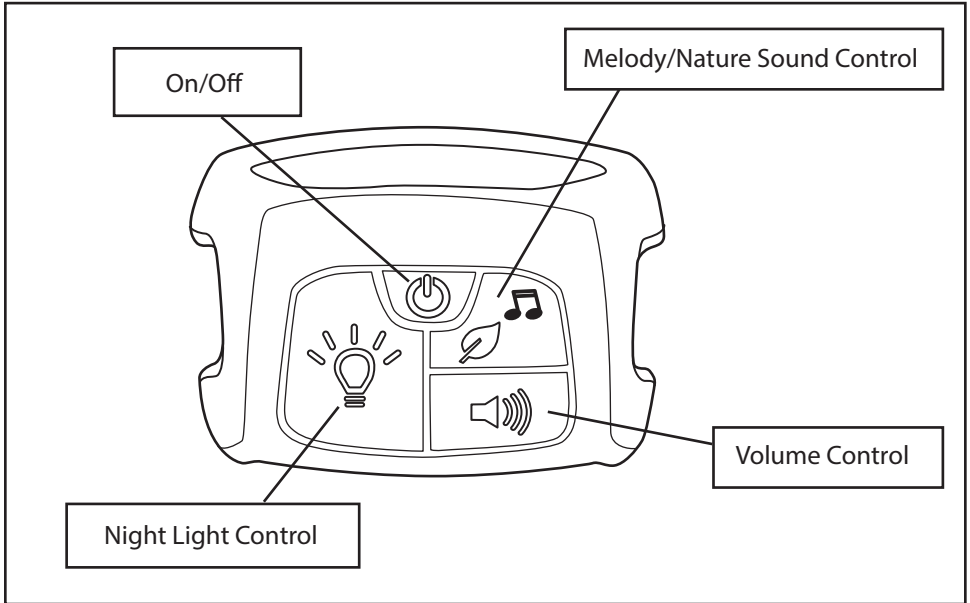

Press the On/Off button to turn the unit on/off.

**To use the sounds / music function** – Press the Melody/Nature Sound button as needed to select the desired nature sound or melody. Press the Volume Control button to select the volume level. Automatic shutoff occurs after 30 minutes.

**To use the Night Light function** – Press the Night Light button to activate light. Automatic shut off occurs after 30 minutes.

# Folding the Travel Cot

1

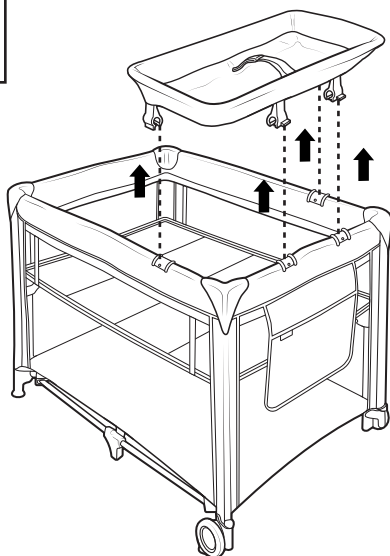

2

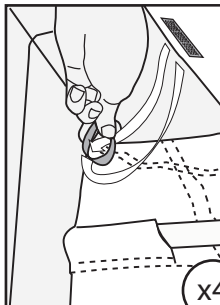
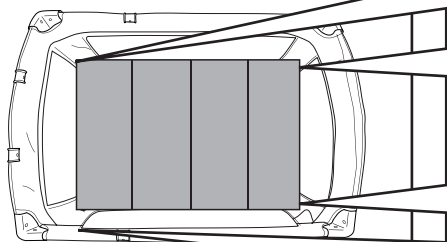

3

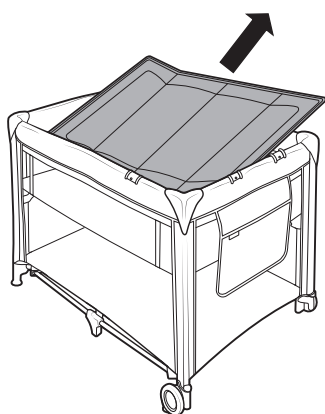

4

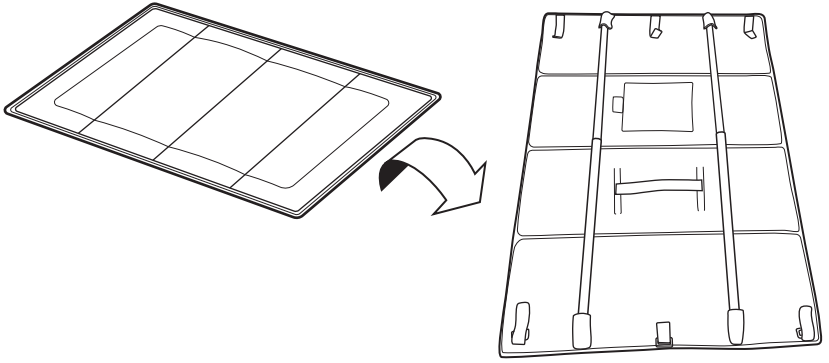

5

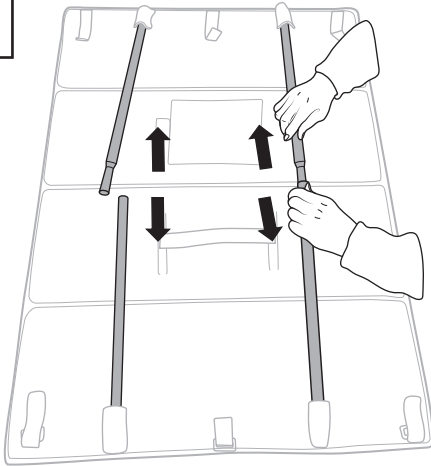

6

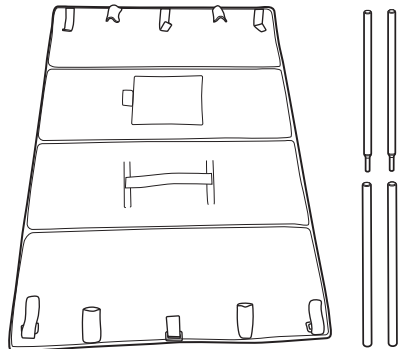
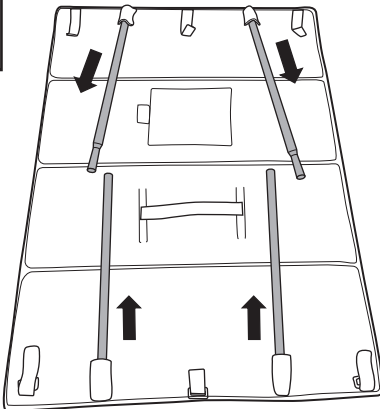

7

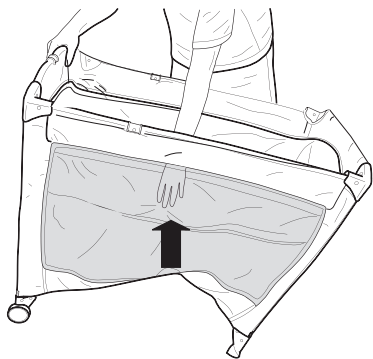

8

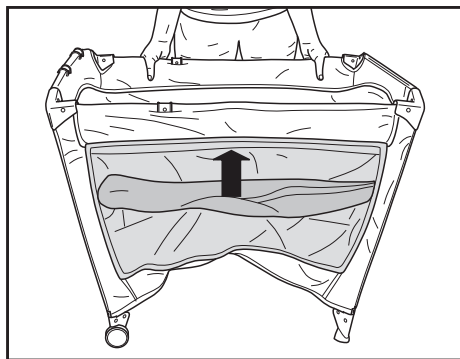

9

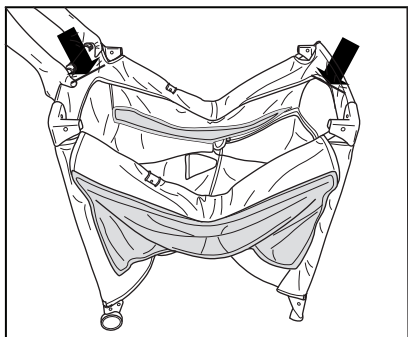

10

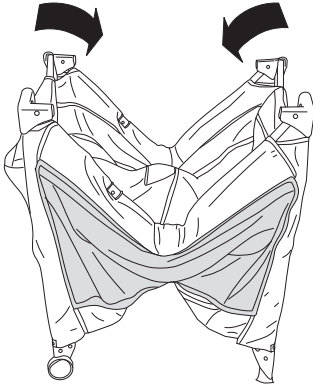

11

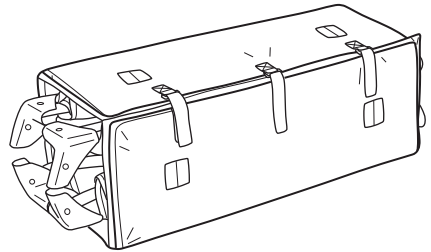
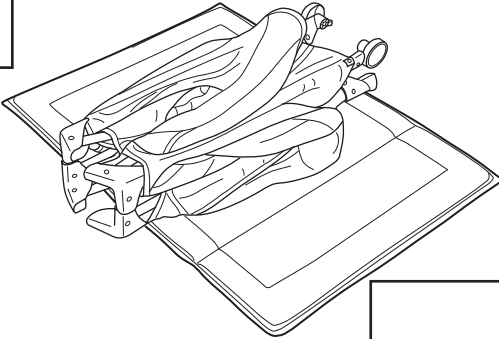

12

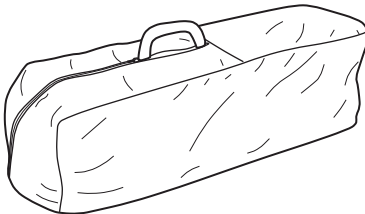

## Removing the Bassinet

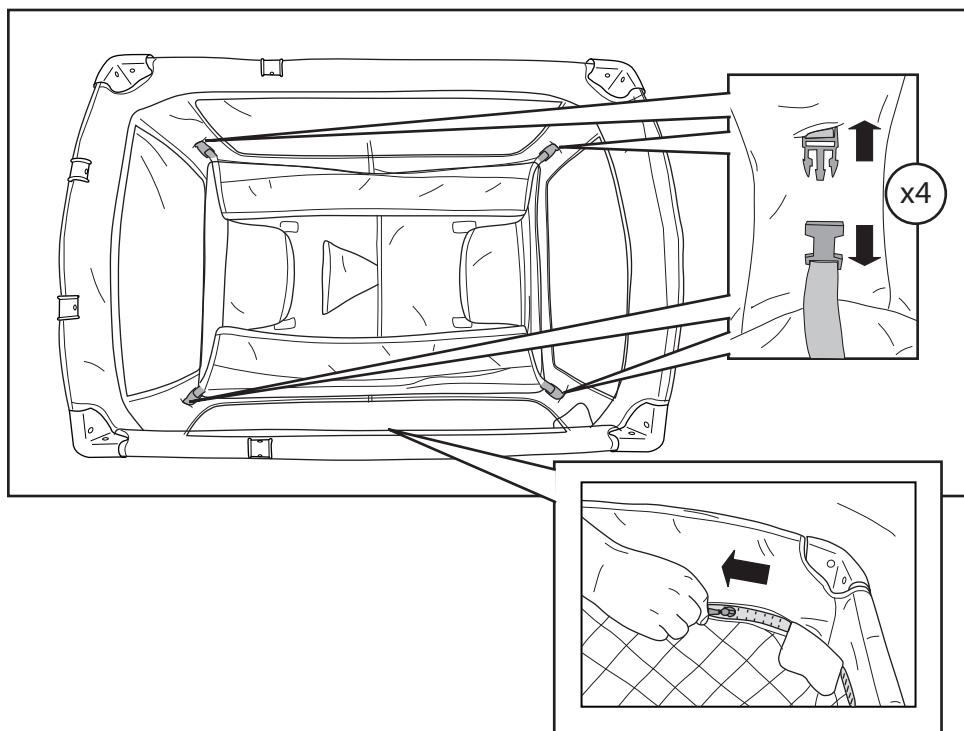

# Playard Setup Without Bassinet

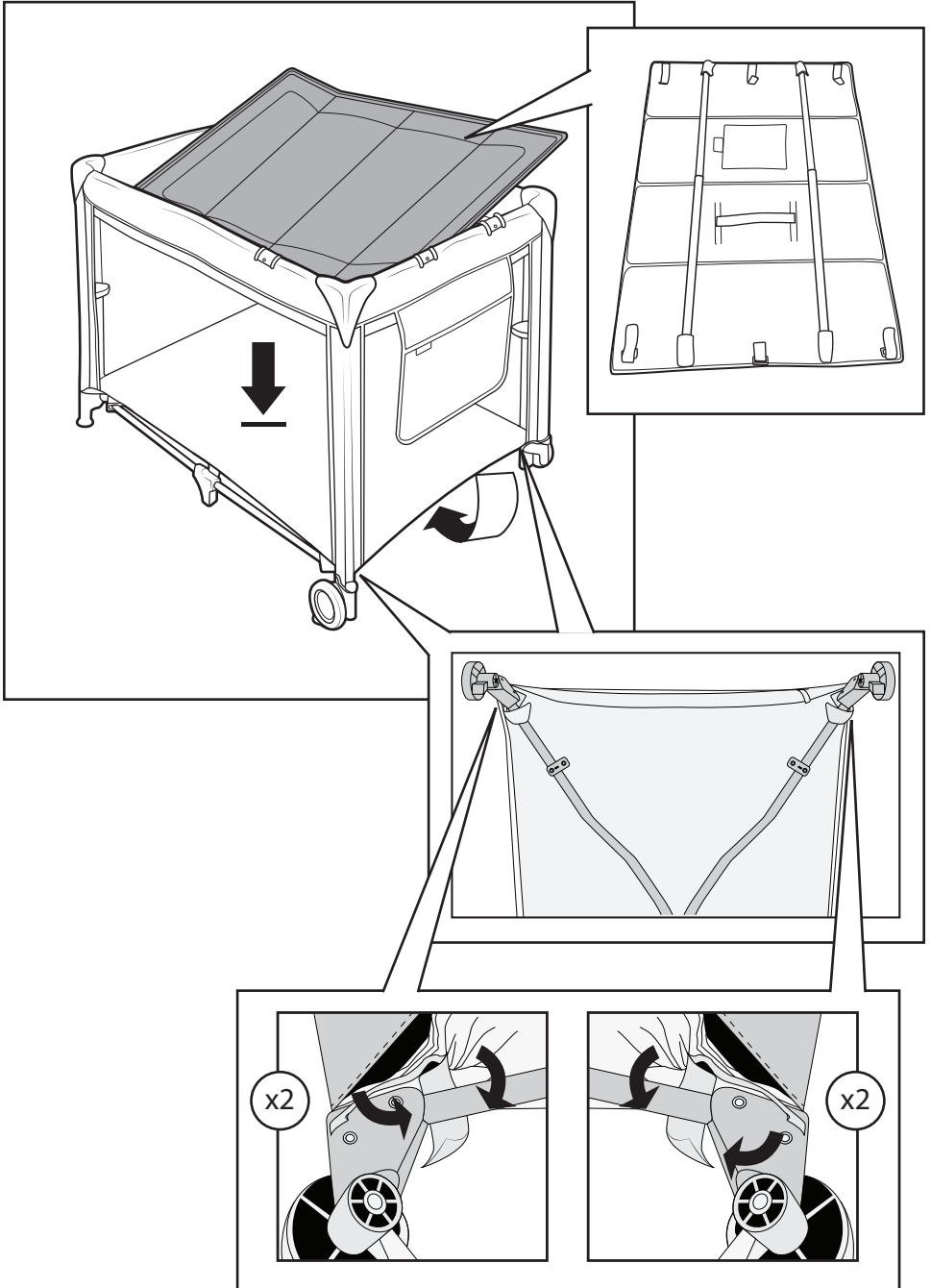

# Installing the Bassinet

1

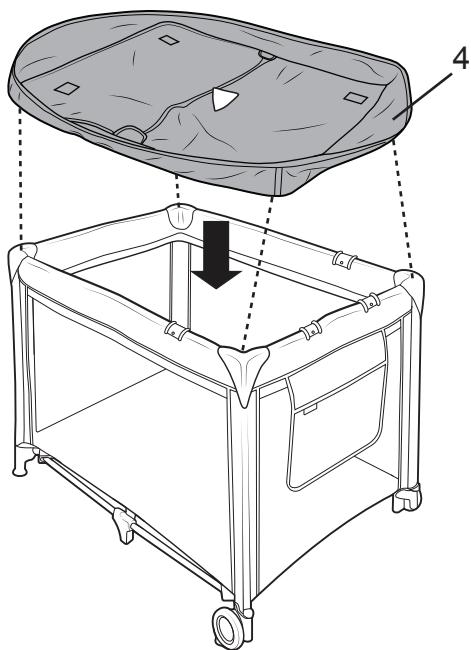

2

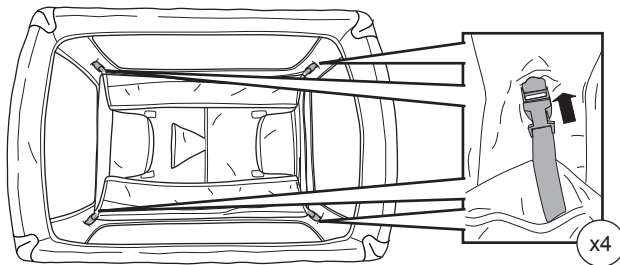



3

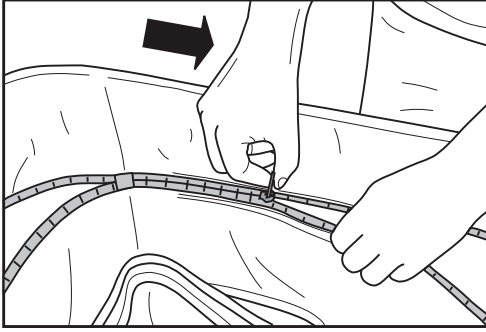

4

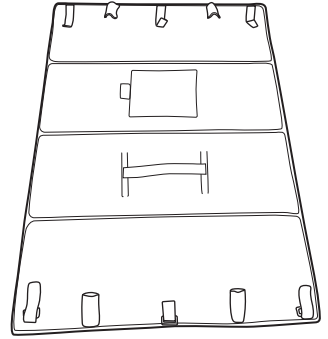
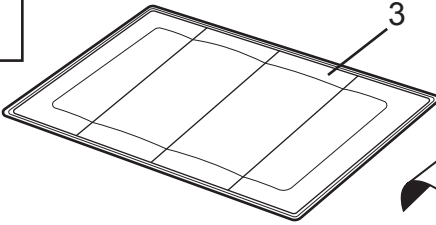

5

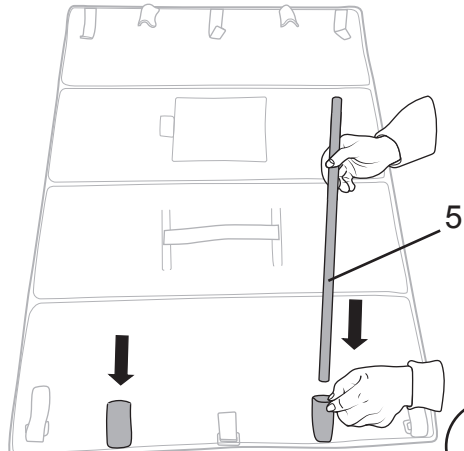
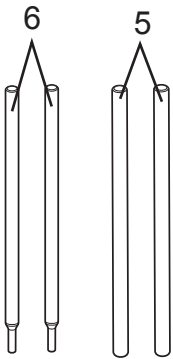

6

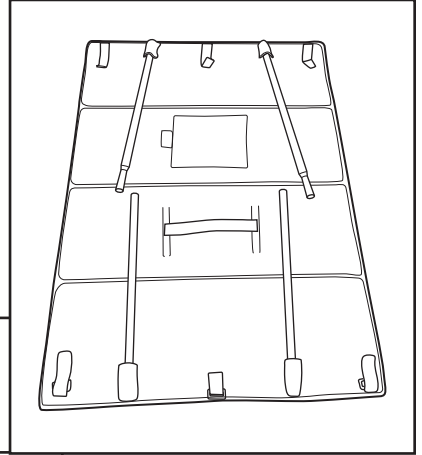
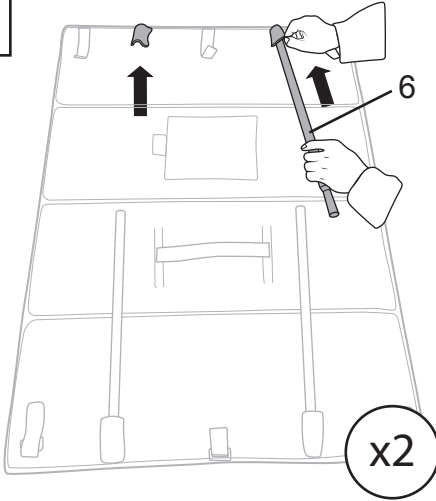

7

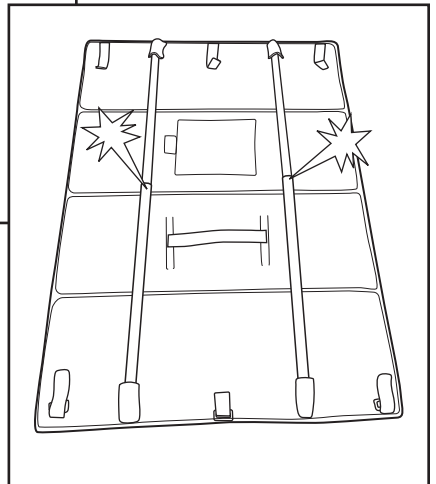
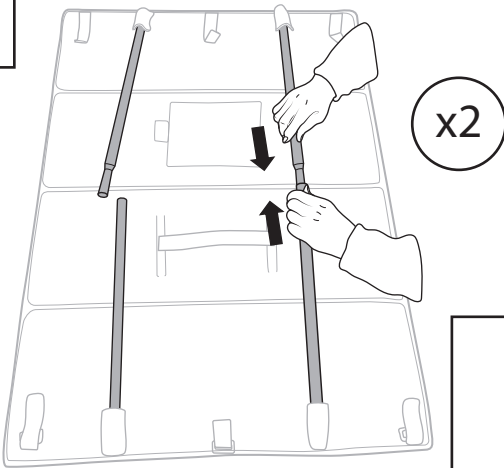

8

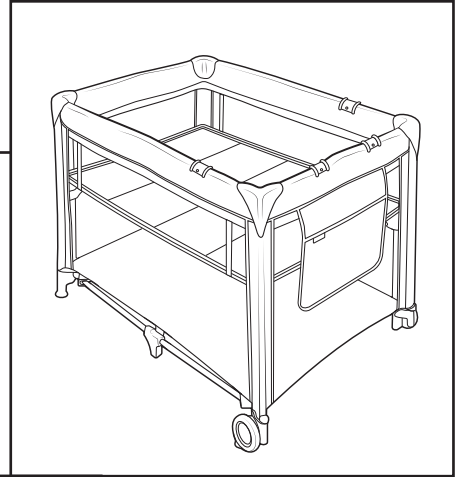

9

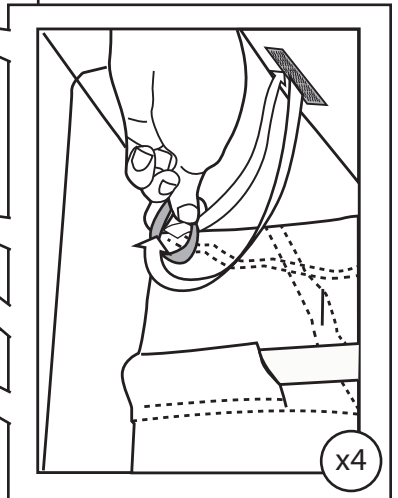
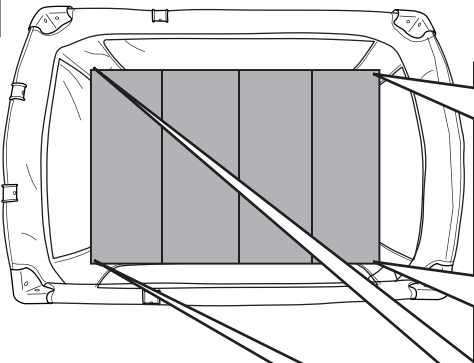

# Kids II®

bright  
starts



baby  
einstein™



ingenuity



oBall

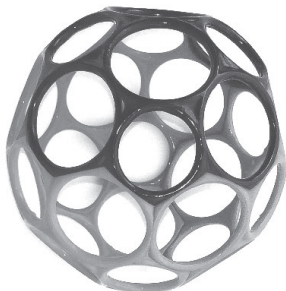

[kidsii.com/discover](http://kidsii.com/discover)

MANUFACTURED FOR • FABRIQUÉ POUR **KIDS II®** • ©2019 KIDS II, INC.  
**KIDS II, INC.**, ATLANTA, GA USA 30305 • 1-800-230-8190 • [www.kidsii.com/help](http://www.kidsii.com/help)  
**KIDS II CANADA CO.** TORONTO, ONTARIO CANADA M2J 5C2 • 1-800-230-8190  
**KIDS II AUSTRALIA PTY LIMITED** CASTLE HILL, NSW AUSTRALIA 2154 • (02) 9894-1855  
**KIDS II JAPAN K.K.** SHINJUKU-KU, TOKYO, JAPAN, 163-0529 • (03) 5322-6081  
**KIDS II US MÉXICO S.A. DE C.V.** AVE. VASCO DE QUIROGA NO. 3900-INT. 905-A COL. LOMAS DE SANTA FE • DELEGACIÓN ÁLVARO OBREGÓN, CIUDAD DE MÉXICO, MÉXICO • C.P. 01219 • (55) 5292-8488  
**KIDS II UK LTD.** 725 CAPABILITY GREEN, LUTON, BEDFORDSHIRE, UK, LU1 3LU • +44 01582 816 080  
**KIDS II AMSTERDAM** • +31 20 2410934

EN • 11961\_AU\_010819\_KN\_Z

PRINTED IN CHINA • IMPRIMÉ EN CHINE