

SIDES		BOTTOM	
6	1/2" KNOCKOUTS	3	1/2" KNOCKOUTS
3	1/2"-3/4" MOON KNOCKOUTS	2	1/2"-3/4" MOON KNOCKOUTS
2 PCS 8-32X1/2 Screws Installed			
Material: Steel-0.0625"-660 Galvanized			

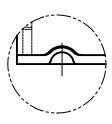
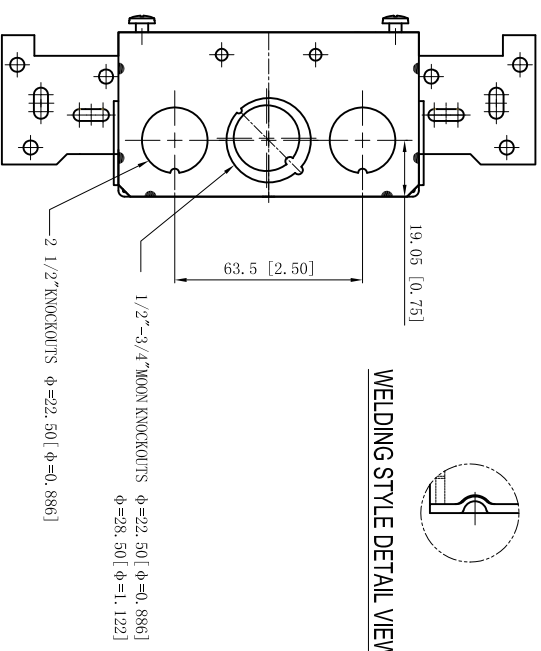
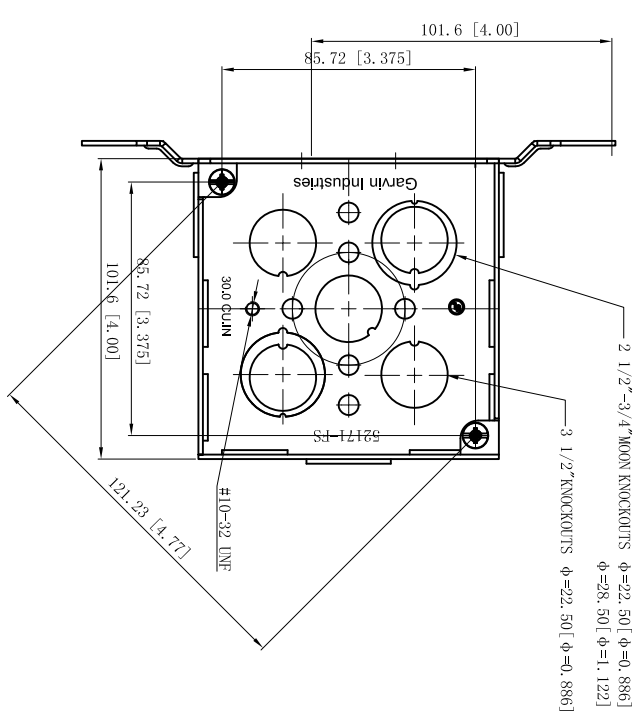
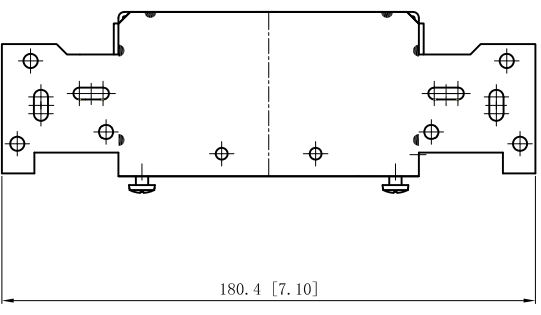
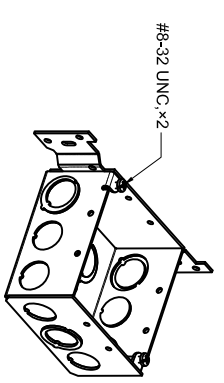
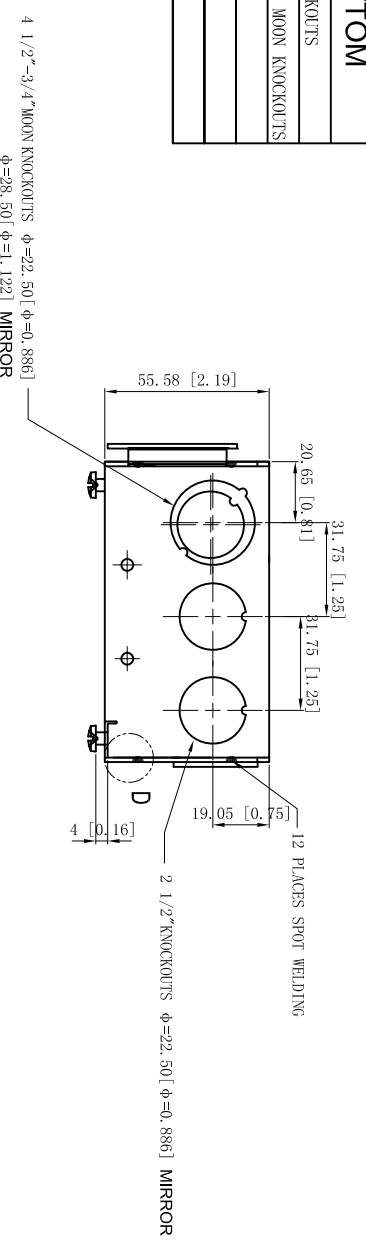

WELDING STYLE DETAIL VIEW D

DESCRIPTION

This data sheet is for reference only. GARVIN INDUSTRIES reserves the right to make changes to the design without prior notice.

STANDARD PACKING

GARVIN INDUSTRIES

25 PCS

4"SQ. BRACKET BOXES (2-1/8"DEEP)

TRADE REFERENCE TERMS

TITLE	52171-FRED	REV	D
SIZE	DWG NO.		
A4	52171-FRED		
	DATA SHEET		