

ChefsChoice®

International

KrumKake Express™



Instructions & Recipes for **Model 839/839-SE**

IMPORTANT SAFEGUARDS

When using electrical appliances, basic safety precautions should always be followed including the following:

1. Read all instructions before using the KrumKake Express™.
2. Do not touch hot surfaces. Always use plastic handle on lid and do not touch stainless cover when hot.
3. To protect against fire, electric shock and injury to persons, do not immerse cord, plug or KrumKake Express™ in water or other liquid.
4. Close supervision is necessary when any appliance is used by or near children.
5. Before use, unwind the power cord completely and keep the cord away from hot parts of the appliance.
6. Do not let power cord hang over edge of table or counter or touch hot surfaces.
7. Do not place on or near hot gas or electric burner, or in a heated oven.
8. Extreme caution must be used when moving an appliance containing hot oil or other hot liquids.
9. Only operate the KrumKake Express™ on a dry, flat, non-slip surface.
10. Do not use the KrumKake Express™ outdoors.
11. Do not operate the KrumKake Express™ with a damaged cord or plug. If it malfunctions or has been damaged in any manner, return the KrumKake Express™ to the EdgeCraft Corporation Service Department for examination, repair or adjustment.
12. The use of accessory attachments not recommended by the EdgeCraft Corporation may result in fire, electric shock or injury to persons.
13. Always unplug the KrumKake Express™ from electrical outlet when not in use and before cleaning, to avoid accidental electrical shock. Allow to cool before cleaning.
14. As long as the appliance is hot, even if unplugged, there is the danger of someone getting burned. Do not touch and do not put it into storage while hot.
15. Do not use the KrumKake Express™ for other than intended use.
16. For use only on 120V 60HZ power. Use a socket with a good ground connection. Do not use a three to two way adapter on the three prong power cord provided.
17. For household use only.
18. **SAVE THESE INSTRUCTIONS.**

YOU MADE A GOOD CHOICE

With the KrumKake Express™, you will want to treat the entire family and neighbors to that great delicacy lauded for ages in Scandinavia and throughout northern Europe. The truly modern and speedy KrumKake Express™ bakes a waffle ready to roll into a small cone in less than 90 seconds. Follow your favorite Scandinavian recipe or any of those suggested here. Fill the cones with traditional whipped cream and Lingonberries or with fruits, preserves, ice cream, French icing or sherbets for impressive desserts on those special occasions.

It is often said that the KrumKake originated in Norway but some in Sweden still argue that point. The Germans have evolved their own recipes for this delicacy, which they call the Hörnchen (little horn). Every region in Germany bakes a slightly different cone filled with local preferences.

The versatile KrumKake Express™, allows you to bake any size waffle up to 6" diameter to a golden brown or darker color. For those enjoying this dessert for the first time we include a collection of our favorite recipes.

GETTING TO KNOW THE KRUMKAKE EXPRESS™

Take a minute to identify the key features of the KrumKake Express™ (Figures 1 and 3). On the right you will see a red “Baking” light and the green “Ready” light. The red light, when lighted, indicates the baking plates are being heated. The green light, when lighted, signals that the baking plates are up to temperature and “ready” to bake. To open the lid, release the locking latch (Figure 2).

The Color Control Dial permits you to adjust the temperature of the waffle plates. In order to bake at a higher temperature, increase the Dial setting. To reduce the temperature, turn the Dial down to a lower setting. You will want to find the optimum Color Dial setting that bakes your krumkake to just the right color. The best setting of the Color Control Dial is usually in the range of 2 to 3 ½. When you find the best setting of the Color Control Dial the baking time is usually 60 to 80 seconds and you may be able to use the sequencing of red and green lights to help time the baking cycle. Otherwise you will find it helpful to use a timer. As you make final adjustments of the Color Control Dial, you will find that only small movements of that Dial, such as ½ graduation, make a noticeable change to the color and timing.

The KrumKake Express™ is equipped with a locking latch designed to minimize lifting of the lid by the batter during the baking cycle and thus maintain uniform thickness. This latch can be conveniently unlocked by lifting the finger release (Figure 2) which is an integral part of the latch.

Provision has been made for cord storage as described in the cleaning and storage section. The cord can be wrapped under the KrumKake Express™ with the electrical plug secured in a slot molded into the base.

The KrumKake Express™ can be stored upright to save shelf space. Simply close the lid and stand it up on the flat hinged end.

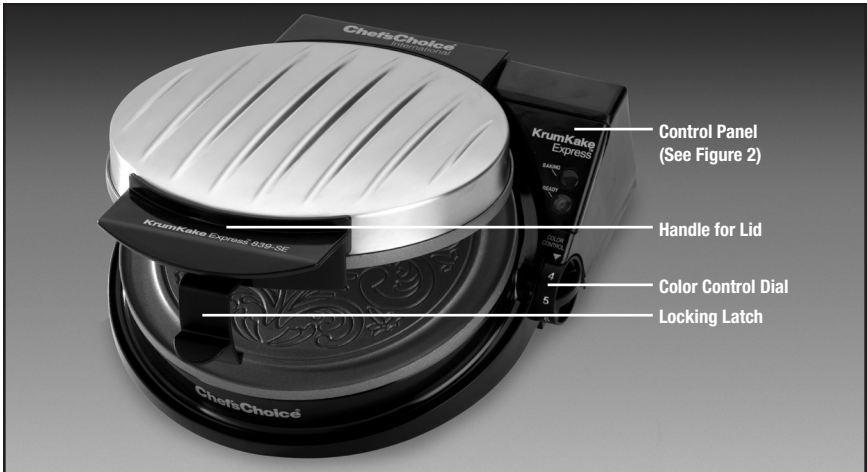

Figure 1. KrumKake Express™.

BEFORE YOU BAKE THE KRUMKAKE

Set the Color Control Dial to about 2 ½ to 3. Close the lid. Insert the KrumKake Express™ power cord into a 120V-60HZ grounded outlet. For consistent baking times let it warm up and cycle a few times to stabilize- about 5 minutes. The Green and Red lights will go on and off alternately a few times.

Spray or wipe the baking plates lightly with a vegetable oil spray the first time you use the KrumKake Express™ and anytime thereafter should your krumkake wafers stick.

Use one of our recommended krumkake recipes included here or select a family favorite. One krumkake (6" diameter) takes a little less than 2 tablespoons of batter. One tablespoon will make a 4" diameter krumkake. For best results, do not overfill the waffle iron.

BAKING YOUR FIRST KRUMKAKE

When the green light is ON, spoon the appropriate amount of batter directly in the center or slightly above the center of the waffle pattern. Promptly close the lid. Press the lid down firmly and, for a still thinner krumkake, fasten the latch which will spread the batter evenly across the baking grid.

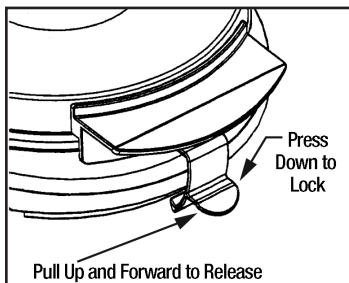

Figure 2. Locking latch.

Lift the lid carefully in 60 seconds to check the color of your first wafer. If the color is too light, bake another 15 to 20 seconds.

It may take a few tries to find the best setting of the Color Control Dial; it is finely calibrated and sensitive. A small movement of the Color Control Dial makes a noticeable difference in the color of the krumkake. Adjust the Color Control Dial ½ graduation higher to darken the cone and ½ graduation lower to lighten the krumkake. When you have the setting just as you like, the green and red lights usually can be used to time your baking cycle.

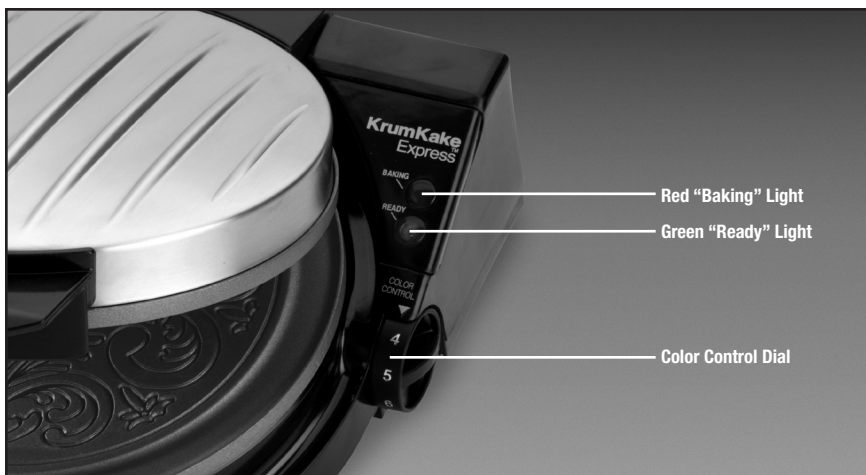

Figure 3. Control panel.

Here is how the red and green timer lights work. Ladle the batter onto the plate when the green light is ON; in about 20-30 seconds it will go off and the red light will come ON. This indicates that the plates are heating. In another 30 to 40 seconds, the red light goes off and the green light will turn ON. Open the lid and check the krumkake. Bake a few more seconds if needed to obtain the best color. If you find it easier, use a timer and bake your cones for 60 to 75 seconds depending on size and desired color.

Note: *Always* unplug the KrumKake Express™ immediately after use. Never leave it unattended when plugged in. Children should not be allowed to use the KrumKake Express™ except in the presence of an attentive adult.

ROLLING THE CONE

The cone form provided with your KrumKake Express™ helps you make uniformly shaped cones with ease. After a few cones, you will develop the knack of holding the warm cone and shaping it into a neat form perfect for your favorite filling.

Follow the illustrated steps the first few times you make cones to perfect your skills. As soon as the wafer is baked, remove it from the KrumKake Express™. Immediately place it on a thin and dry soft cloth as shown below (Figure 4). Position the point of the cone-form, near the circumference of the edge of the krumkake with the cone-form resting across the diameter of the krumkake. Use the edge of the cloth to lift one edge of the krumkake up onto the cone form. Then using the cloth initially to help support the hot krumkake, press it snugly against and partially around the cone form (Figure 5). Then let the cloth fall back as you roll the cone forward until the krumkake completely enwraps the cone form (Figure 6). Hold the krumkake on the cone form. With the overlapped seam of the krumkake down under the cone, press firmly down against the waffle and cone form to “freeze” the cone into shape. Hold the cone around the form in this way until it is sufficiently cool and stiff enough to hold its shape.

The cloth helps to protect your fingers from the hot waffle. If your fingers are comfortable with the heat, you may find the cloth unnecessary.

Set the warm cone aside in a cone holder or on its side until it cools or until you are ready to serve. If you plan to use the cones later, allow them to cool and dry completely before storing in a sealed plastic bag or tightly covered container. Most cones will keep several weeks when packaged this way and stored in a cool dry place.



Figure 4.

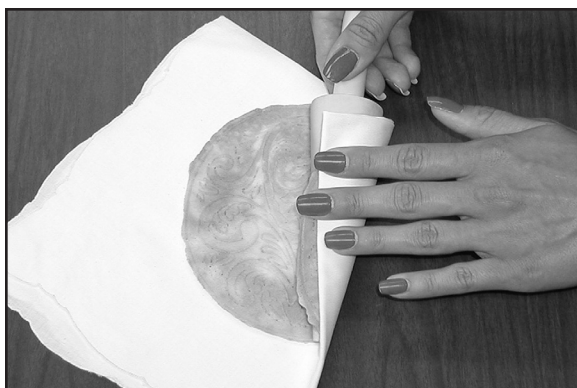

Figure 5.



Figure 6.

RECIPES FOR DELICIOUS KRUMKAKES

Personal preferences for the krumkake vary from a light, lacy texture to a heavier consistency. You may want to experiment with both the Scandinavian and German recipes included here. The relative amounts of the main ingredients of the krumkake batter, namely flour, butter, sugar and egg, vary significantly in the following recipes. The Scandinavian recipes are richer in butter, sugar and eggs. You will find any of the following recipes easy to prepare and outstanding for flavor and texture.

A Favorite German Recipe

For a crispy yet easy to roll krumkake try the following:

⅔ cup water

1 cup general purpose flour

½ stick butter (¼ cup)

1 egg

½ to 1 teaspoon vanilla

½ cup granulated sugar (or slightly more for taste)

1. Boil the water. While it is cooling, add ½ stick butter to water and stir to melt the butter completely. Add ½ cup of granulated sugar to water while still warm and stir to dissolve. Allow to cool.
2. Add one cup of general purpose flour and 1 egg. Mix thoroughly while adding ½ to 1 teaspoon of vanilla. This mixture will be relatively thin and will produce a thin crispy krumkake. Bake to a golden brown.
3. Start with Color Control Dial at 2½. Use approximately 1½ tablespoons for a full 6" wafer. Spoon the mix onto heated plates when "Ready" green light is ON. Lock the lid latch. The green light will go OFF in about 30 seconds and the red "Baking" light will come ON. The green light will come ON again in about another 30 seconds. Then open the lid of KrumKake Express and inspect wafer. Cook longer if needed to reach a golden brown color.
4. Readjust Color Control dial if necessary to obtain a total bake cycle of about 80 seconds and a golden brown color. Remove the wafer from KrumKake Express™ and roll quickly (while hot) around the Cone Form.

Makes about 15 krumkakes.

A Norwegian Favorite

A delightful krumkake, easy to handle and roll into a cone, yet light and crispy.

⅓ stick butter (5 tablespoons)

⅓ cup milk

⅓ cup granulated sugar

1 cup general purpose flour

2 eggs

1. Melt the butter carefully in microwave oven or double boiler. Do not overheat. Then thoroughly mix in the sugar, stirring well. Add the two eggs and with a power mixer, blend the mixture until light yellow colored. Add the milk and flour and continue to blend until mixture is smooth. The batter should flow readily but slowly off of a measuring spoon for a thin yet easy to handle krumkake.
2. Any of a variety of flavorants such as vanilla extract (½ teaspoon), grated lemon rind (½ teaspoon), almond extract (½ teaspoon) or ground almonds (1 tablespoon) can be added to vary the flavor.
3. Start with Color Control setting of 2½. One tablespoon of batter will make a five (5) inch krumkake. Lock the lid latch for a thinner and crispier krumkake. Add batter to plate only when green “Ready” light is ON. In about 30 seconds the red light will turn ON. When green light comes ON again, promptly inspect krumkake for color. Cook until golden brown and remove promptly. Roll onto cone form quickly while krumkake is still hot.

Makes about 20 krumkakes.

A Norwegian Recipe for a Lacy KrumKake

Try this variation for a lighter, very lacy krumkake.

1 stick butter (½ cup)

1 cup general purpose flour

2 tablespoons whipping cream

1 cup sugar

½ teaspoon vanilla extract

3 large eggs

1. Melt the butter carefully in microwave oven or double boiler. Do not overheat. Add sugar to melted butter and mix thoroughly. Using a power hand mixer blend the eggs into the mixture. Then add the flour slowly while blending to a smooth consistent batter.
2. In a small bowl whip the cream fully. Then add and completely blend the whipped cream into the batter. Add vanilla extract to suit your taste. If needed, add a small amount of milk while blending until the consistency is just spoonable but not quite pourable. The mixture should drop off a measuring spoon but not pour off. This consistency will ensure a lacy texture krumkake, but you will find the baked krumkake slightly more difficult to handle without tearing while rolling into a cone. But its worth the effort.
3. Use the latch to obtain a thinner, lacier wafer. For a slightly thicker krumkake do not close the latch while baking.
4. Start with the Color Control setting at 2½. One heaping tablespoon makes a 5 to 6” diameter krumkake. Add batter to the plate only when green “Ready” light is ON. In about 30 seconds the red light will turn ON. When green light comes ON again, promptly inspect krumkake for color. Cook until golden brown and remove promptly. Roll onto cone form quickly while krumkake is still hot. Adjust Color Control dial as necessary to obtain a total bake cycle of 70-80 seconds for a golden brown krumkake.

Makes about 25 krumkakes.

Fillings for the KrumKakes

This is where the fun begins. The options are endless. Whether you prepare conventional cones or filled sandwich cookies you will want to experiment with any of the great variety of European and American fillings.

Sweetened Whipped Cream

A popular choice and the clear favorite in Scandinavia:

- 1 cup whipping cream**
- 3 tablespoons confectioner sugar**
- ½ teaspoon vanilla**

Whip the cream until stiff. Add and blend in the confectioner sugar and vanilla. Mixture should be stiff. If too thin add more sugar. If too stiff add a little cream. Add lingonberries or small cranberries for color and contrasting flavor. Serve promptly while whipped cream is still stiff.

For variety, coat the edge of the cone with melted dipping-chocolate.

Other Fillings

The variety of readily available fillings is virtually endless. Consider the following:

- | | |
|---|---|
| Chocolate fudge | Sherbets |
| Chocolate pudding | Ice cream |
| Diced fruits or with whipped cream | Preserves and jams – strawberry, raspberry, etc. |
| Sour cream with tart jelly | Custards or puddings – any flavor |
| Cream cheese with fruit | |

SERVING SUGGESTIONS

Remember the versatile KrumKake Express™ can be used to prepare delicious ice cream cones. The German recipe for the krumkake (Hörnchen) can be used to make cones substantial enough to hold ice cream. For a festive occasion let the family roll their own cones and try filling while still warm for a softer ice cream. Set out your favorite ice cream, sherbet, toppings, chocolate chips and nuts. Some may want to serve a warm flat krumkake on a plate with ice cream on top. The warm wafer will melt some of the ice cream for a striking blend of flavors.

Also ice cream cones can be prepared and filled in advance and conveniently stored in the freezer upright on cone-stands, now available in specialty stores.

KrumKake wafers make a wonderful crisp cookie wafer that can be used to garnish ice cream parfait or puddings. Simply cut the wafer into four neat triangles while it is warm. Cool and dry the triangles on a wire rack and store in a sealed container free of moisture.

Cones should never go to waste. Less than perfect cones can be cooled then crumbled and used to garnish desserts. Crumbled cones make an interesting addition to pie crusts and cheesecakes.

At holiday time, try forming the warm wafers into bowl shapes to be filled and eaten with ice cream, frozen yogurt, or fresh berries with whipped cream. If you have a 3 or 4 inch muffin tin, press the wafer while hot into the tin mold. Crimp the edges to make the wafer fit into the mold. A small bowl or custard cup can also be used for a mold. A pair of fluted muffin tins about 3-4 inch diameter are ideal for making a krumkake bowl - simply press the warm wafer between the tins.

CORD SAFETY

A short power supply cord is provided with this appliance to reduce the risk resulting from someone in or becoming entangled tripping over a longer cord and causing the KrumKake Express™ to overturn. While EdgeCraft does not recommend it, extension cords are available and may be used if care is exercised in their use. If an extension cord is used, the marked electrical rating of the extension cord should be at least 15 amperes. The longer cord should be arranged so that it will not hang over the counter-top or tabletop where it can be pulled on by children or pets or tripped over.

CLEANING AND STORAGE

Before cleaning the KrumKake Express™, always unplug the power cord and wait until the plates cool to room temperature. Never clean the appliance under water. If you find it necessary to clean the baking surface use a soft brush, Q-tip, or a flexible moist cloth. Never use a sharp or pointed metal tool that will damage the non-stick surfaces. The exterior can be safely cleaned with a mild detergent on a damp soft cloth or small soft brush. Then use a dampened cloth followed by wiping with a dry soft cloth.

Store the power cord under the bottom as shown in Figure 7 and insert the strain relief adjacent to the power plug into the plastic slot located under the left side of the KrumKake Express™. You will find it is easy to store it upright resting on the top hinged face as shown.

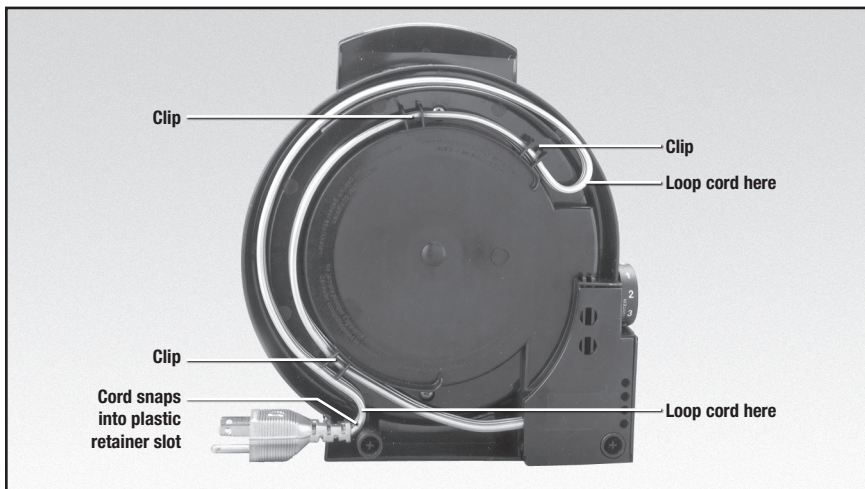

Figure 7. Cord clips under base. KrumKake Express™ stores upright as shown.

SERVICE

This appliance is for household use only. No user-serviceable parts are inside. Refer servicing to qualified personnel.

In the event service is needed, return your KrumKake Express™ to EdgeCraft Corporation, where the cost of repair or electrical or mechanical adjustment can be estimated before the repair is undertaken. If failure occurs within the warranty period there may be no charge.

Please include your return address and a brief description of the problem or damage to the KrumKake Express™ on a separate sheet inside the box.

EdgeCraft

World Leader in Cutting Edge Technology®

EdgeCraft Corporation

825 Southwood Road, Avondale, PA 19311 U.S.A.

Customer Service (800) 342-3255 or 610-268-0500

Chef'sChoice® and EdgeCraft® are registered trademarks of EdgeCraft Corporation, Avondale, PA.

Conforms to UL Std. 1083 Certified to CAN/CSA Std. C22.2 No. 64-M91

© EdgeCraft Corporation 2012

Printed in China.

H12

www.chefschoice.com

W839200