

SMART HOME KEY DOOR LOCK PALM

IMPORTANT SAFETY INSTRUCTIONS AND INSTALLATION GUIDE

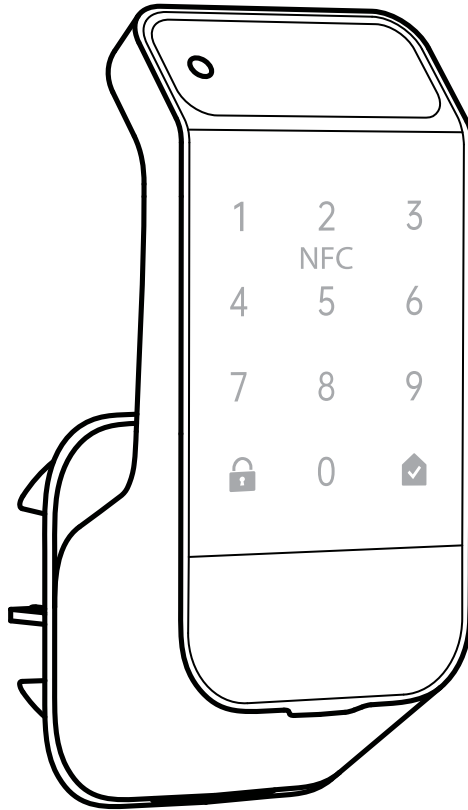

READ BEFORE INSTALLATION
SAVE THESE INSTRUCTIONS



Table of Contents

Safety Information	2
FCC Statement	2
Warranty Information	2
Pre-Installation	3
Tool Required	3
Hardware Included	3
Product Overview	4
Installation	5-6
App Setup	7
Using your Door Lock - Outdoor	8
Using your Door Lock - Indoor	9
Restore Factory Settings	10
Emergency Power Supply	11
Local Assistive Features	11

Safety Information

For your safety, always remember to:

- Install batteries only after the door lock is fully installed and all mechanical checks are complete.
- Use only high-quality AA alkaline (LR6) batteries. Do not mix battery types or brands.
- Replace all four batteries at the same time. Dispose of batteries according to local regulations. Do not incinerate batteries. Do not mix old and new batteries. Recycle when possible.
- If the low-battery alert sounds, replace the batteries immediately.
- Keep backup keys in a secure but accessible place for emergency use.
- Keep the sensor and keypad clean for reliable operation.
- Do not attempt to disassemble, repair, or modify the lock yourself.
- Doing so may cause damage, void the warranty, or result in malfunction. For service, please contact qualified technicians or customer support.

FCC STATEMENT

Supplier's Declaration of Conformity:

47 CFR § 2.1077 Compliance Information

Responsible Party: Feit Electric Company

4901 Gregg Road, Pico Rivera, CA 90660, USA

www.feit.com

Unique Identifier: USI/DOOR/LOCK/PS/HK

This device complies with part 15 of the FCC Rules. Operation is subject to the following two conditions: (1) This device may not cause harmful interference, and (2) this device must accept any interference received, including interference that may cause undesired operation. Note: This equipment has been tested and found to comply with the limits for a Class B digital device, pursuant to part 15 of the FCC Rules. These limits are designed to provide reasonable protection against harmful interference in a residential installation. This equipment generates, uses and can radiate radio frequency energy and, if not installed and used in accordance with the instructions, may cause harmful interference to radio communications. However, there is no guarantee that interference will not occur in a particular installation. If this equipment does cause harmful interference to radio or television reception, which can be determined by turning the equipment off and on, the user is encouraged to try to correct the interference by one or more of the following measures: Reorient or relocate the receiving antenna. Increase the separation between the equipment and receiver. Connect the equipment into an outlet on a circuit different from that to which the receiver is connected. Consult the dealer or an experienced radio/TV technician for help. Any changes or modifications not expressly approved by the manufacturer could void the user's authority to operate the equipment.

Radiation Exposure Statement

This device complies with FCC radiation exposure limits set forth for an uncontrolled environment. This device should be installed and operated with a minimum distance of 20cm between the radiator and your body.

Regulatory Information (Required by Law)



CALIFORNIA PROPOSITION 65 WARNING: This product can expose you to chemicals including lead, which is known to the State of California to cause cancer and birth defects or other reproductive harm. For more information about this regulation: www.P65Warnings.ca.gov

Warranty Information

ONE-YEAR WARRANTY

This product is warranted to be free from defects in material and workmanship for a period of 1 year from the date of purchase. For products containing a sealed battery, this warranty does not cover any damage that may be caused by the battery. Warranty does not apply to replaceable battery. This warranty applies only to the original consumer purchaser and only to products used in normal residential use and service. If this product is found to be defective, the only obligation, and your exclusive remedy, is the repair or replacement of the product, at the company's discretion, provided that the product has not been damaged through misuse, abuse, accident, modification, alteration, neglect, or mishandling. This Warranty shall not apply to any product which is found to have been improperly installed, set-up, or used in any way not in accordance with the instructions supplied with this product.

RETURNS

For replacement of this door lock under the terms of this Warranty, please contact customer service at universalsecurity.com/help for assistance. The company does not warrant, and specifically disclaims any warranty, whether express or implied, of fitness for a particular purpose, other than the warranty contained herein. No implied warranty on this product, created by state law, shall extend beyond the term of this warranty unless such law otherwise provides. The company specifically disclaims any liability and shall not be liable for any consequential or incidental loss or damage, including, but not limited to, damages to any equipment with which this product is used. Some states do not allow the exclusion or limitation of incidental or consequential damages, so the above limitations or exclusions may not apply to you. No agent, representative, dealer, or employee of the company has the authority to increase or alter the obligations or terms of this Warranty. This Warranty gives you specific legal rights and you may also have other rights which vary from state to state. This Warranty is only valid for merchandise purchased from outlets in the United States and Canada. This warranty expires upon product end-of-service life signal.

TOOLS REQUIRED (NOT INCLUDED)

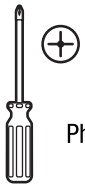

Phillips Screwdriver



NOTE: Hardware not shown to actual size.

HARDWARE INCLUDED

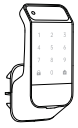

AA

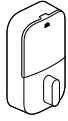

BB

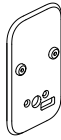

CC

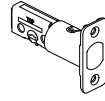

DD



EE



FF



GG



HH



II



JJ

Part	Description	Quantity
AA	Outdoor keypad	1
BB	Inside Knob	1
CC	Mounting Plate	1
DD	Deadbolt	1
EE	Strike Plate	1
FF	Self-Tapping Screw (M4)	4
GG	Connecting Screw	2
HH	Bottom Base Screw	2
II	Emergency Key	2
JJ	AA Batteries	4



NOTE: If any items are missing, do not install the lock and contact customer support.

Product Overview

 **NOTE:** Tap your iPhone or Apple Watch on the NFC area to unlock the door using Apple Home Key.

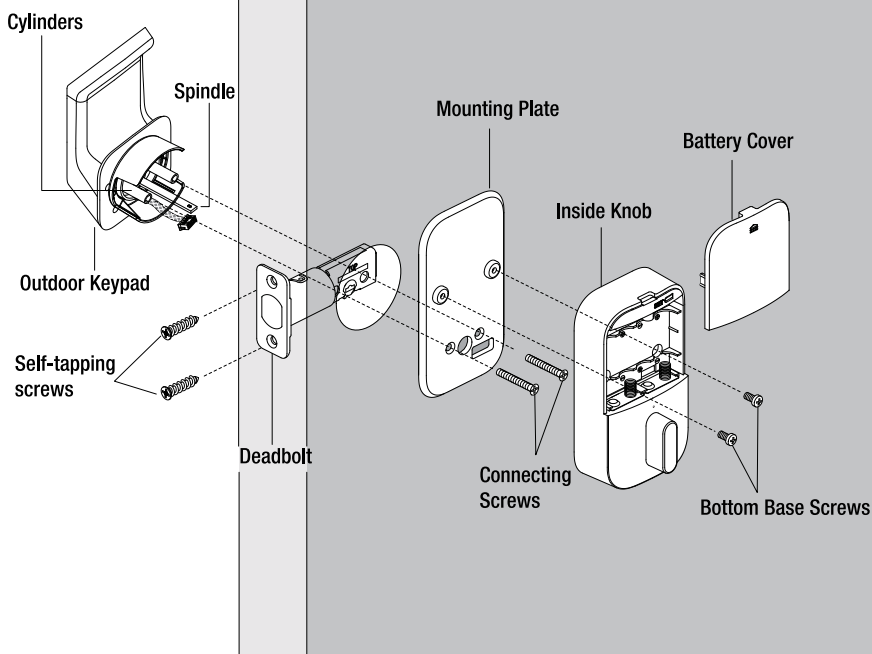
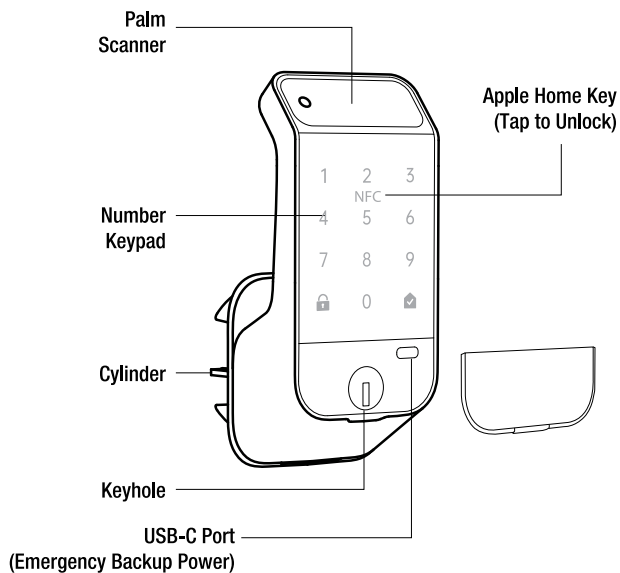

Product Specifications

Function	Content
Access Methods	Mobile app, Palm scan (touch-free), Keypad code, and Physical backup key, apple watch home key, Iphone home key
Battery Specifications	4 x AA Alkaline Batteries (LR6)
Battery Life	Range 4-6 months, 10 unlocks/locks per day
Supported Users	Stores up to 50 palm profiles and 50 keypad codes
Operating Temperature	Outdoor keypad: -4°F to 131°F (-20°C to 55°C)
Inside Knob	14°F to 131°F (-10°C to 55°C)

1 Getting Started

- Check fit: Measure your door and door frame to confirm they match the required dimensions.
- Remove old hardware: Take out the original door bolt.
- Reuse existing parts (if possible): The original strike box may be kept and used.

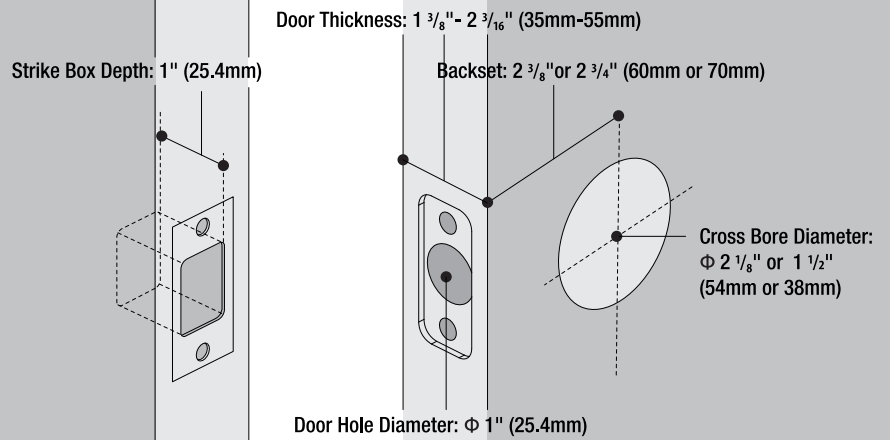

2 Installing the Deadbolt

- Adjust the deadbolt (DD) to $2 \frac{3}{8}''$ (60mm) or $2 \frac{3}{4}''$ (70mm) according to the backset, and insert it into the door hole with self-tapping screws (FF) to tighten.
- Press the strike plate (EE) into the slot as shown and secure it with self-tapping screws (FF).



NOTE: Be sure that the "TOP" icon is always facing up. Installing it upside down will prevent the lock from working.

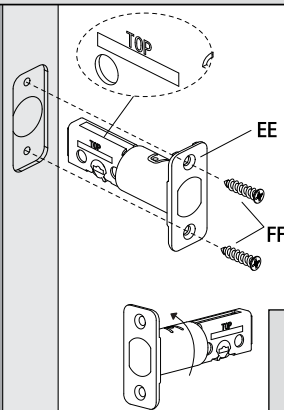
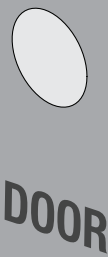

NOTE: The original strike plate can be reused for use.

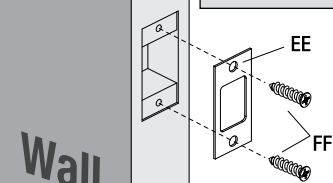

NOTE: The Backset can adjust from $2 \frac{3}{8}$ (60mm) to $2 \frac{3}{4}$ (70mm) by reversing the deadbolt direction about 180 degrees.

3 Installing the Outdoor Keypad

- Insert the outdoor keypad (AA) into the deadbolt (DD) as shown. Make sure it is aligned parallel to the door frame, with the wire connector running under the deadbolt to the other side.



NOTE: If the diameter of the door hole is $1 \frac{1}{2}''$ (38mm), please pull off the glove before installing the exterior assembly.

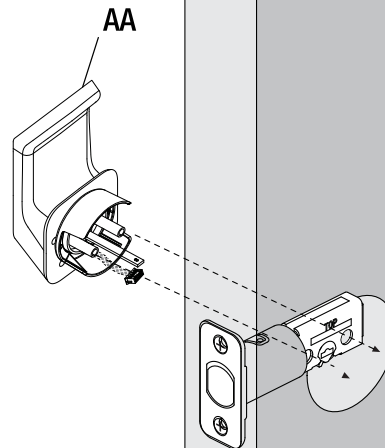
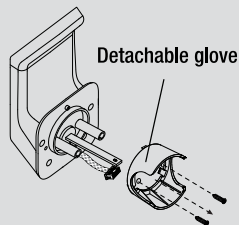

4 Installing the Mounting Plate

- On the inside of the door, place the mounting plate (CC) over the opening.
- Make sure to get the center post through the hole and align the cylinders to the holes of the mounting plate.
- Tighten the base plate using the connecting screws (GG).



NOTE: The wire connector extends from the hole under the deadbolt.

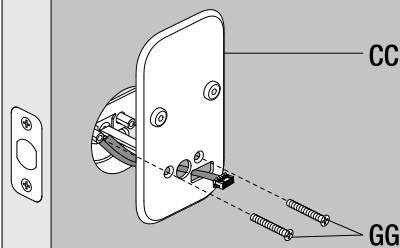

5 Installing the Inside Knob

- Plug the cable from the Outdoor Keypad (AA) into the Inside Knob (BB) until it clicks securely.
- When placing over the mounting plate, tuck the excess wire into the slot to avoid pinching.
- Insert the spindle horizontally and make sure the knob is set to the unlocked position.
- Align the inside knob (AA) to the mounting plate holes (CC) then tighten using the bottom base screws (HH)

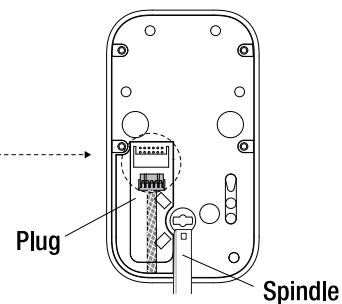
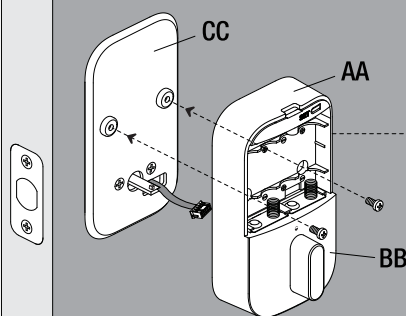

Insert the plug into the connector as shown, making sure it is fully seated and secure.

6 Installation Testing

- Make sure the lock operates smoothly. Turn the knob manually clockwise and counterclockwise to test locking and unlocking.
- Install 4 x AA Alkaline Batteries.



NOTE: The lock can be locked and unlocked with the emergency key.

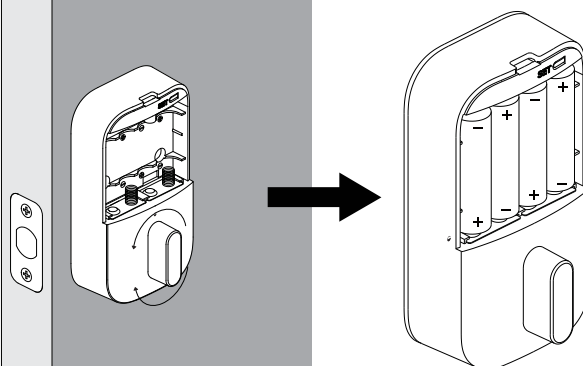
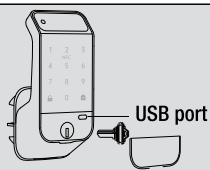

Download and install the Universal Security Instruments App

- ❑ Search for the Universal Security Instruments App Store or Google Play Store.
- ❑ Download and install the Universal Security Instruments App on your smart device.



Universal Security Instruments App



Set up the Door lock using the Universal Security Instruments App

- ❑ Make sure the door lock is in pairing mode. If it is not, see the pairing/reset instructions on page 10.
- ❑ Open the Universal Security Instruments App and tap the “+” icon in the top-right corner.
- ❑ Confirm that Bluetooth is enabled on your mobile device, then check if the lock appears at the top of the screen.
- ❑ On the app home screen, tap the “+” icon or 'Add Device.'
- ❑ Press the SET button located under the battery cover to enter pairing mode.
- ❑ The indicator light will flash blue, signaling the lock is in pairing mode.
- ❑ Ensure your mobile device has Bluetooth enabled and is connected to the same Wi-Fi network.
- ❑ Select your lock from the list of nearby devices and follow the prompts to complete the connection.
- ❑ Once paired, the lock will automatically calibrate to detect the door’s opening direction.

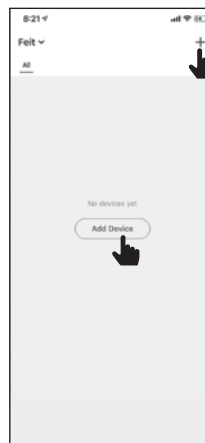

Connect to Smart Home Devices

If you use smart home assistants such as Apple Home, Alexa, or Google Home:

- ❑ Open the USI App and go to the smart lock’s main page.
- ❑ Tap the three-dot menu (...) in the top right corner and select Connect to Matter Network.
- ❑ Follow the on-screen instructions to link your lock with your preferred platform.
- ❑ After successful setup, you can control and monitor your lock using voice commands or the platform’s app.

Compatible Devices

This lock supports Matter connection and can work with the following devices:

- ❑ Apple HomePod (2nd Gen), HomePod Mini, Apple TV 4K (2021 & 2022 models)
- ❑ Amazon Echo (4th Gen)
- ❑ Echo Show 8/10/15, Echo Studio, Echo Plus, Echo Hub
- ❑ Eero 6/6+/Pro/Pro 6E/Max 7 and Eero PoE Gateway models
- ❑ Google Nest Hub (2nd Gen), Nest Hub Max, Google TV 4K, Nest Wifi Pro
- ❑ Samsung SmartThings Hub v3, Station, Dongle, Aeotec SmartThings Hub
- ❑ Samsung Smart TVs (2023+), Smart Monitors (M80C+), Q-Series Soundbars (2023+)
- ❑ Samsung Bespoke Family Hub refrigerator (2023+)



NOTE: For the best performance, ensure your mobile device and smart home hub are connected to the same Wi-Fi network during setup. If pairing fails, reset the lock and try again.

App Guide



- ❑ Scan to learn how to navigate the app features.

1 Unlocking From Outside

- Palm unlock

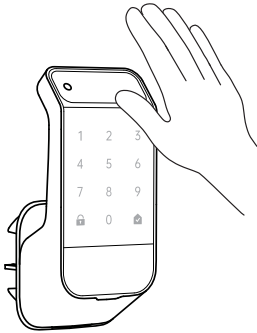

 **NOTE:** Maintain a distance of 6-10 inches (15–25 cm) between your hand and the sensor panel during operation.

- Password Unlocking



- Mobile App Unlocking



- Key Unlocking

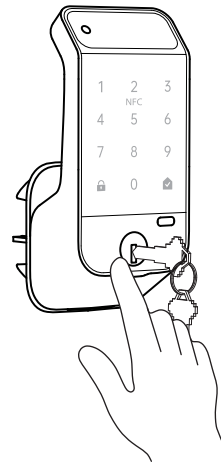

 **NOTE:** Remove the key cover from the bottom of the lock, insert the key, and turn to unlock.

2 Locking from Outside

- Auto-lock mode – The door automatically locks about 5 seconds after unlocking. You can adjust the timing in the app.
- Manual mode - Press the number key on the panel to wake up the device, then press [🔒].

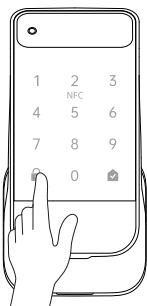

- Key mode - Remove key cover and insert key and rotate.

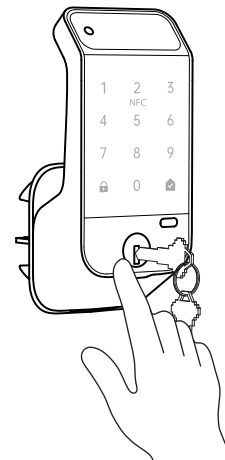

1 Unlocking from Inside

- Unlock from indoors

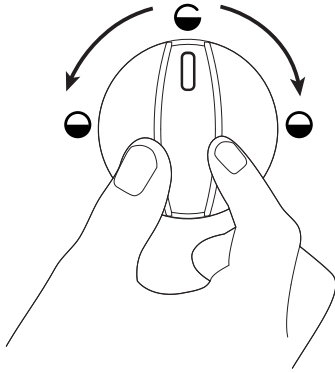

Turn knob to unlock position

2 Locking from Indoors

- Auto lock mode - the device will lock automatically.
- Manual mode

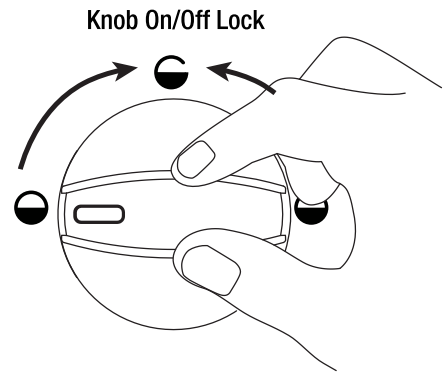

Rotate to the locked position

- Mobile App Unlocking



Restore Factory Settings

- When the door lock is reset to factory settings, all user keys will be cleared, and all local programming features will be reset to their original factory settings. Additionally, the app will be automatically unbound.

1 Method 1

- Open the battery cover on the back panel, then press and hold the [SET] button for 5 seconds. Initialization is complete when the green light on the front panel turns on.

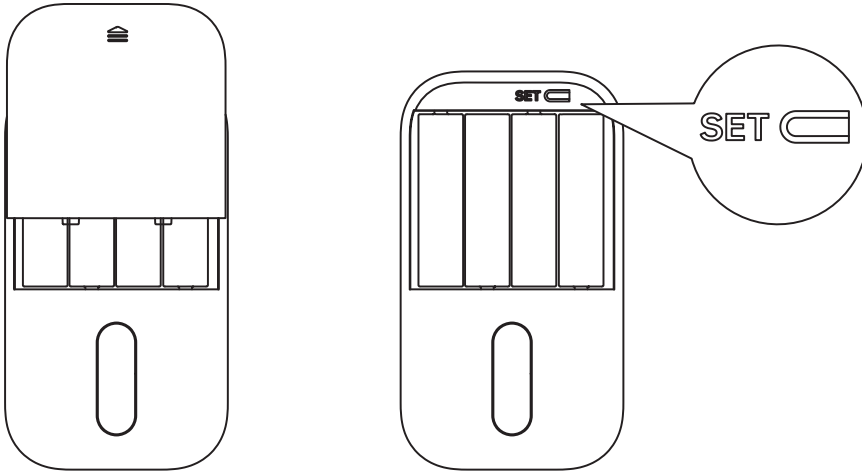

2 Method 2

- Using the app, tap “Remove Device” in settings.

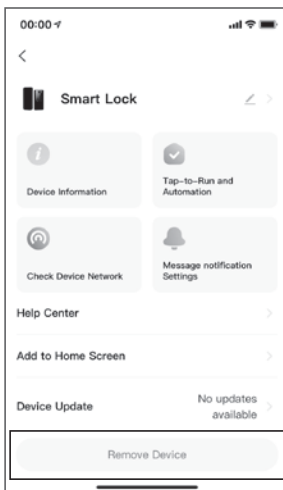

1 Using the Emergency Power Bank Port

- When batteries are depleted on the unit, pop off the cover by pulling on the tab near the bottom.



NOTE: When Batteries are 20% or lower the low battery indicator light will come on.



NOTE: The emergency power bank port provides temporary power only while connected.

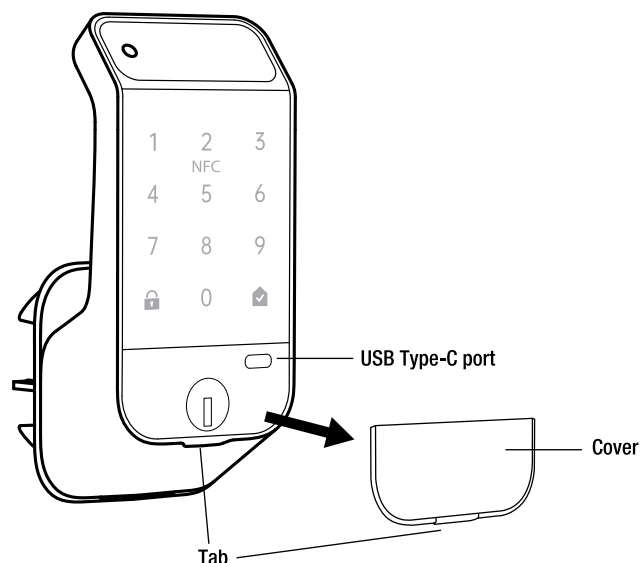

Local Assistive Features

1 Automatic Locking

- After unlocking, the lock will automatically lock and extend within 5 seconds. By default, this feature is turned off (you can customize the locking delay time between 5 seconds to 30 min).

2 Key Function

- The key unlocking function is always available when the battery is completely drained or if the user password is forgotten.

3 Input Error Limit

Palm Scan:

- The lock will disable for 3 minutes after 8 consecutive unsuccessful attempts within 5 minutes.

Password:

- The lock will disable for 3 minutes after 5 consecutive incorrect password attempts within 5 minutes.

4 Silent Mode

- Pressing the button will emit a beep sound (the prompt voice can be silenced in the app).

5 Automated Unlock

- You can schedule automatic lock and unlock times to ensure the door operates on your preferred schedule.

6 Scramble Code (Anti-Peep Password)

- Users can prevent exposure of the unlocking password by entering random digits before and after the password, with a total length of 16 characters (as shown in the image).

