

INSTRUCTION MANUAL

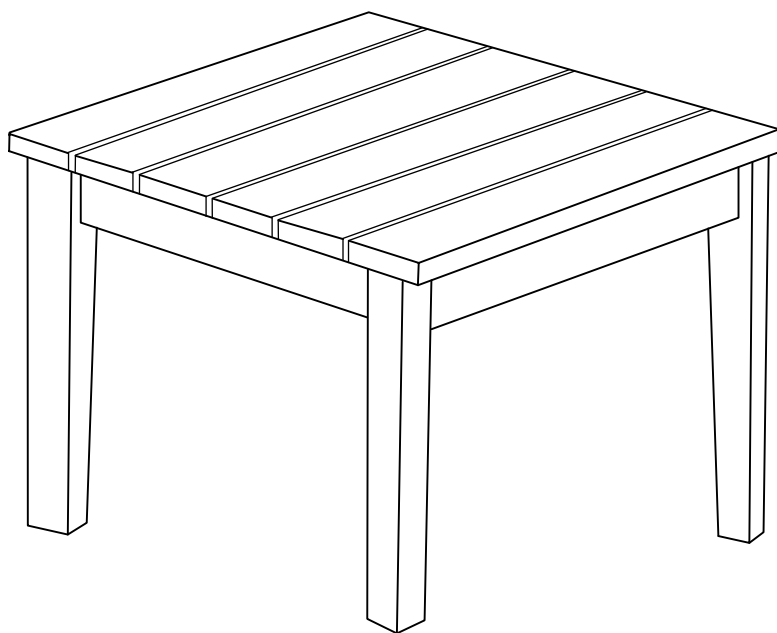

Shoreside Modern 32" Conversation Table
SKU : OP8002

V1.0

! CARE & MAINTENANCE

Please keep this instruction for your future reference.

- Be careful when assembly, avoid hurting the table top surface.
- Clean the table with lukewarm water, mild detergent & soft cloth.
- Firmly secure all bolts before use, do not use any part of this item as a step ladder.
- Reconfirm that all bolts, screws, and nuts are secure every 90 days.
- Do not use or store this item in the proximity of open flame or flammable/combustible chemicals.
- Be aware that some parts are heavy and have sharp edges.
- Do not overtighten screws. (Insert all screws before tighten screws.)
- Please do not exceed the weight limitations of this item.

TOOLS REQUIRED



ALLEN WRENCH
(PROVIDED)



TABLE
110 LBS
CAPACITY



1 PERSON
ASSEMBLY



UP TO 20 MIN.
ASSEMBLY

HARDWARE

1

SCREW
M6.3 x 50mm

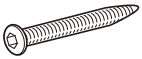

8 PCS

2

ALLEN
WRENCH



1 PC

PARTS

A

TABLE TOP
WITH APRON

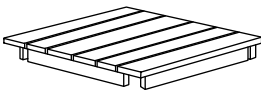

1 PC

B

TABLE LEG - I

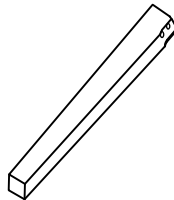

2 PCS

C

TABLE LEG - II

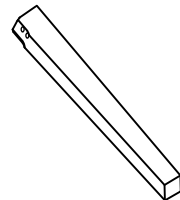

2 PCS

PRODUCT ASSEMBLY

1

Place Part A Table Top upside down, onto soft surface like carpet to avoid damage table top surface.

Attach part C Legs-II to part A Table Top with 4 pcs of Hardware 1 Bolt. Pay attention that the legs facing each other diagonally as below.

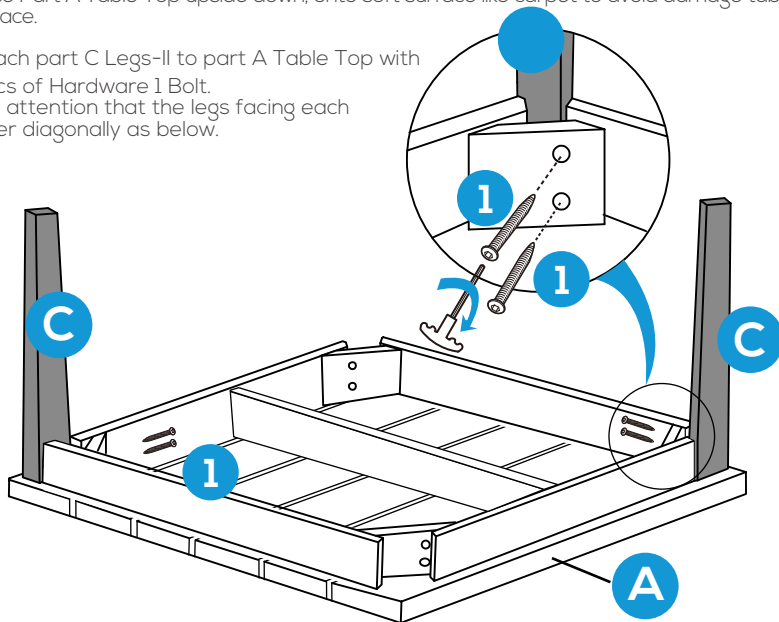

ATTENTION:

Two pairs of legs with different holes to assemble. Try the other pair of legs if you find the holes don't match.

2

Attach part B Legs-I to part A Table Top with 4 pcs of Hardware 1 Bolt.

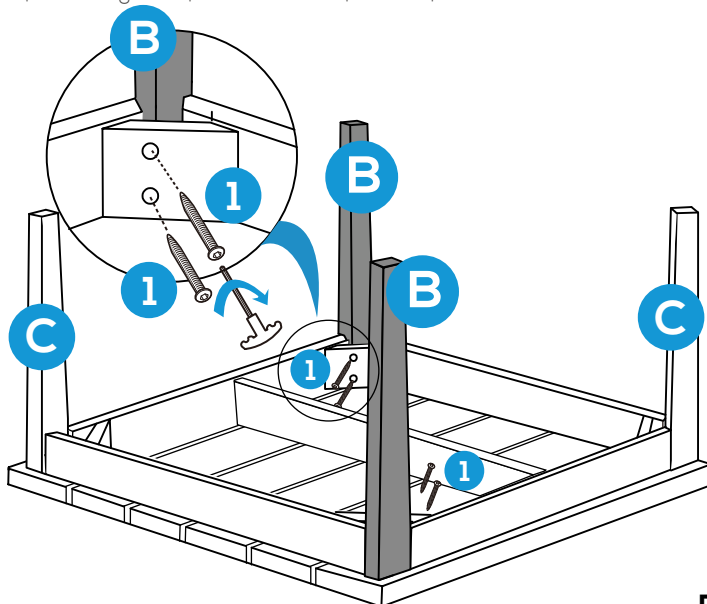

PRODUCT ASSEMBLY

3

Tighten all the bolts again to ensure this table is stable enough to use.

