

# INSTRUCTION MANUAL

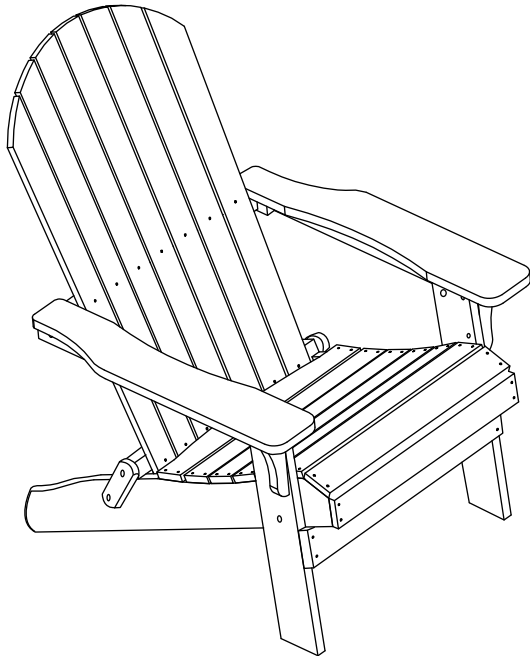

**Outdoor Folding Adirondack Seashell Chair**  
**SKU: OP6010**

**V1.0**

## ! NOTICE

### Do not overtighten screws. (Insert all screws before tighten screws.)

- Please do not exceed the weight limitations of this item.
- Do not stand on or use any part of this item as a step ladder.
- Firmly secure all bolts, screws and nuts before use.
- Reconfirm that all bolts, screws, and nuts are secure every 90 days.
- Do not use or store this item in the proximity of open flame or flammable/combustible chemicals.
- Be aware that some parts are heavy and have sharp edges.
- Please adjust the speed slowly when you use electric drill for assembling to avoid screw slippage.
- Be very careful when folding chair to avoid smashing your hands or fingers.

## TOOLS REQUIRED



ALLEN WRENCH  
(PROVIDED)



SCREWDRIVER  
(PROVIDED)



WRENCH  
(PROVIDED)



CHAIR  
330 LBS  
CAPACITY



1 PERSON  
ASSEMBLY



UP TO 30 MIN.  
ASSEMBLY

## HARDWARE

1 M4 x 40mm  
SCREW



8 PCS

2 M6 x 50mm  
BOLT



2 PCS

3 M6 x 55mm  
BOLT



4 PCS

4 M6 x 60mm  
BOLT



2 PCS

5 M6 x 90mm  
BOLT

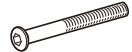

2 PCS

6 WASHER



16 PCS

7 M6 NUT



6 PCS

8 ALLEN  
WRENCH



1 PC

9 SCREWDRIVER



1 PC

10 WRENCH



1 PC

## PARTS

A

CHAIR BACKREST

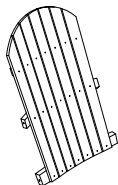

1 PC

B

CHAIR SEAT

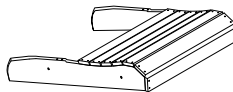

1 PC

C

RIGHT CHAIR ARM



1 PC

## PARTS

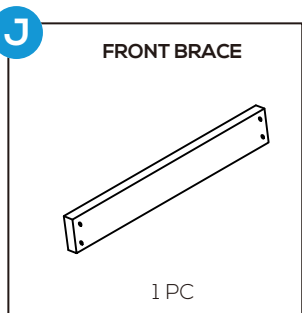
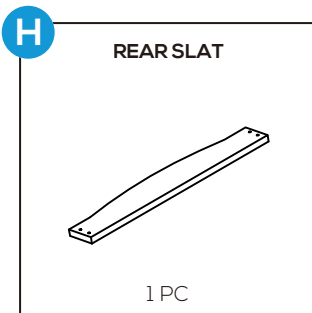
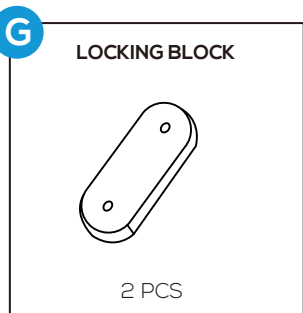
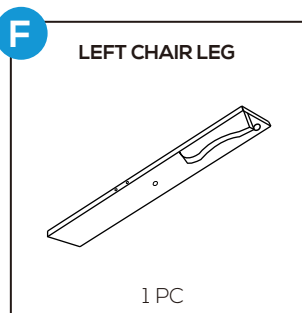
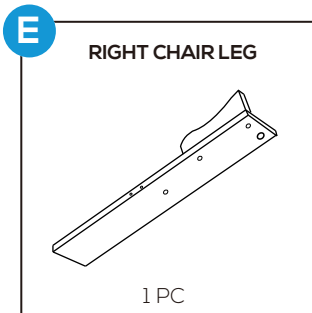
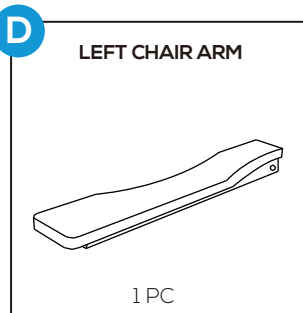

## PRODUCT ASSEMBLY - OVERALL VIEW

Look at the overall view of this chair and learn the exact position of each part to be assembled.

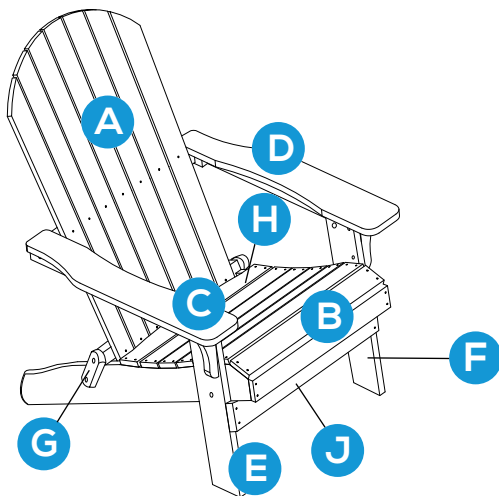

## PRODUCT ASSEMBLY

1

Place part H Rear Slat onto part B Chair Seat as below, attach the rear slat with 4 pcs of hardware 1 Screw.

Attention: Keep countersink holes facing upward and put screws in.

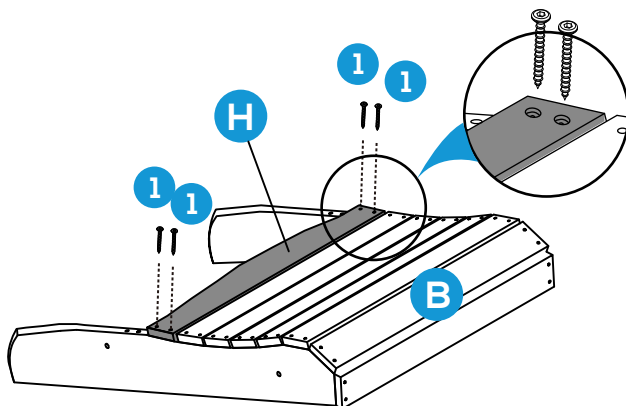

2

Place part E Right Chair Leg to combined part ( B + H ) Chair Seat with 3 sets of hardware 4 Bolt, hardware 6 Washer (2 pcs) and hardware 7 Nut,

Attention: 1 pc of Hardware 6 Washer is assembled between seat and leg.

Do the same to attach part F Left Chair Leg to combined part ( B + H ).

Do not tighten screws or bolts too much at this stage.

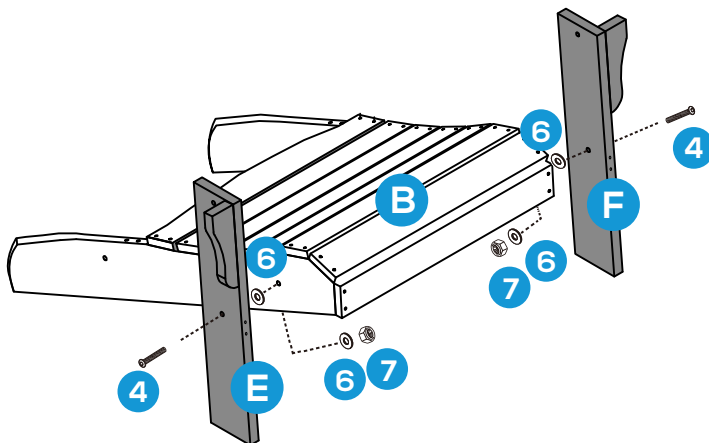

## PRODUCT ASSEMBLY

3

Attach part J Front Brace to part E and part F Chair Legs with 4 pcs of hardware 1 Screw.

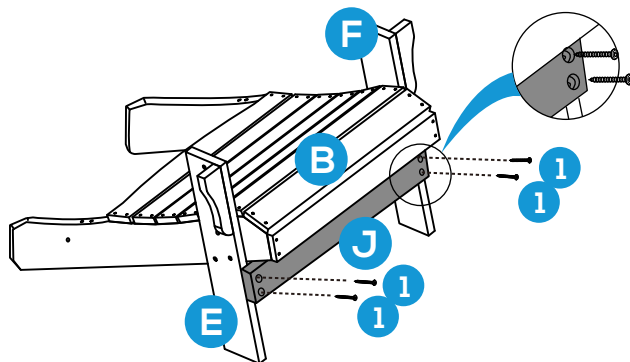

4

Attach part D Left Chair Arm to part F Left Chair Leg with 1 set of hardware 3 Bolt, hardware 6 Washer (2 pcs) and hardware 7 Nut as below.

Do the same to attach part C Right Chair Arm to part E Right Chair Leg.

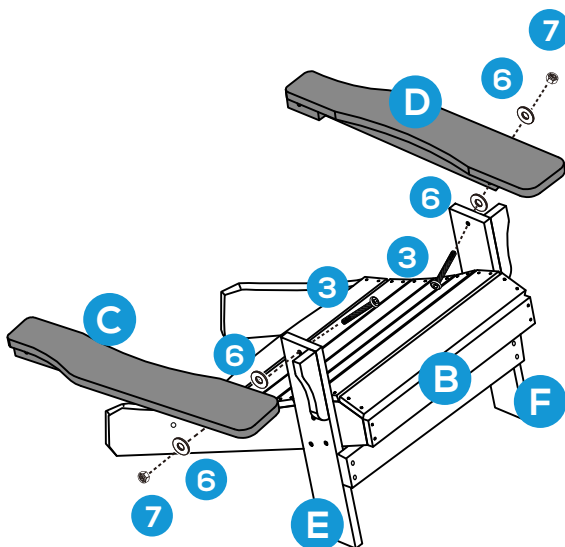

## PRODUCT ASSEMBLY

**5**

Attach 2 pcs of part G Locking block to part B Chair Seat with 2 sets of hardware 3 Bolt, hardware 6 Washer (2 pcs) and hardware 7 Nut.

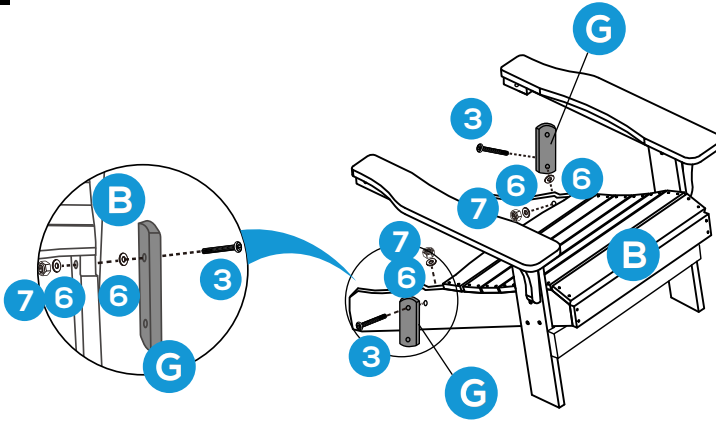

**6**

Place part A Chair Backrest onto part B Chair Seat as below.

Attach the Chair Backrest to part D and part C Chair Arms with 2 pcs of hardware 5 Bolt as well as 2 pcs of hardware 6 Washer.

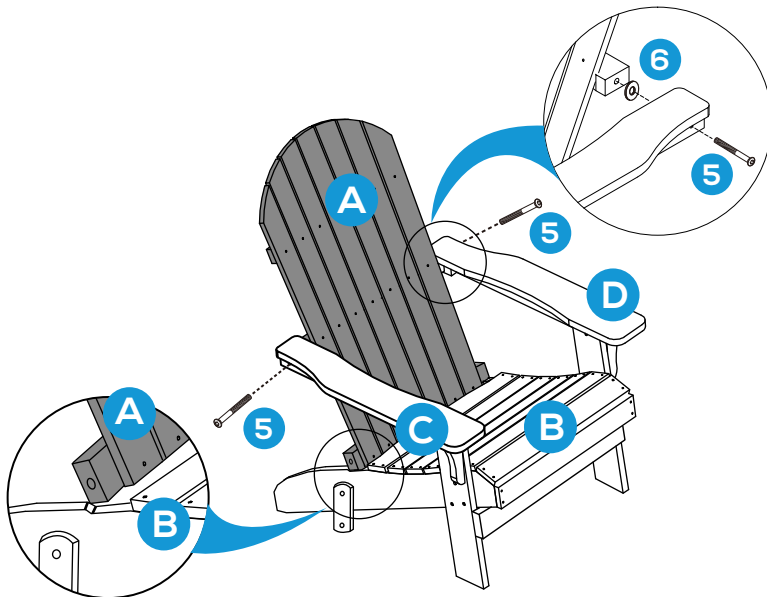

## PRODUCT ASSEMBLY

7

Attach part G Locking block to the bottom brace of part A Chair Backrest with 2 pcs of hardware 2 Bolt and hardware 6 Washer.

Tighten all bolts again to ensure the steady of this chair.

Attention: Push the backrest forward and meantime pull the locking block backward to fold this chair.

