

INSTRUCTIONS FOR MODELS

CPT-1124

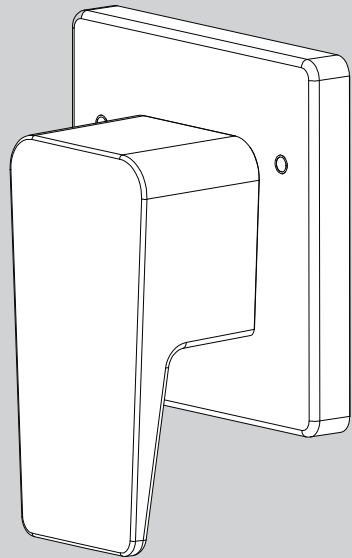

NEED HELP?

For additional assistance or service please contact:

SPEAKMAN®

800-537-2107

customerservice@speakman.com

www.speakman.com

92-CPT-1124-04

TOOLS AND SUPPLIES



IMPORTANT

- Do not over tighten any connections or damage may occur.
- Be sure to read instructions thoroughly before beginning installation.
- This transfer valve has an operating range of 20-80 psi.

SAFETY TIPS

Cover your drain to prevent loss of parts. Be sure to wear eye protection while cutting pipe.

MAINTENANCE

Your new Speakman Product is designed for years of trouble-free performance. Keep it looking new by cleaning it periodically with a soft cloth. The use of harsh chemicals and abrasives on any of the Speakman custom finish products may damage the finish and void the product warranty. Please be sure to only use approved cleaners. Please contact Speakman for any clarification of acceptable cleaners.

WARRANTY

Warranty information can be found at: www.speakman.com

- 1 Clean wall surface. Place Mounting Base (1), on to valve, align mounting holes, and secure with Mounting Screws (2).

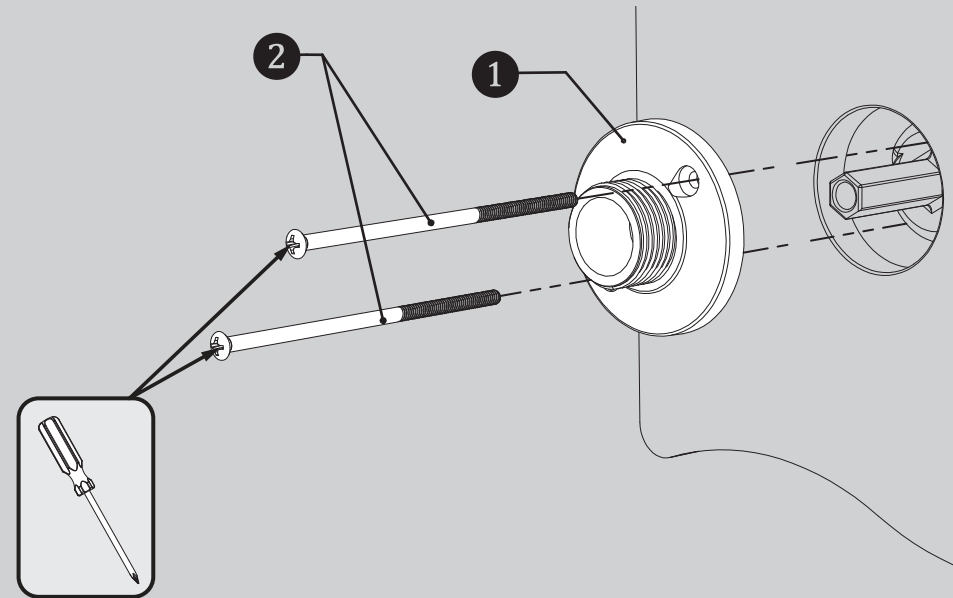

- 2 Place Wall Plate (1) onto Mounting Base. Take care to align the Wall Plate as shown below.

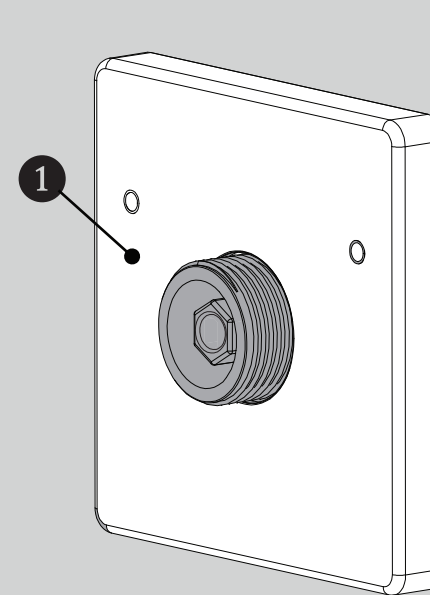

- 3 Place Handle Adapter (1) into the recessed area of the Retaining Collar (2). The angled edge of the snap feature should be facing forward.

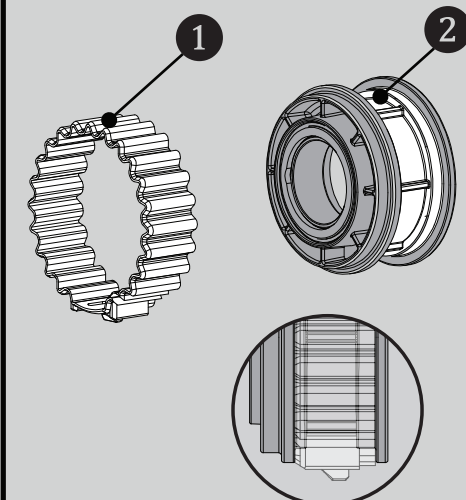

* PROPER ALIGNMENT OF HANDLE ADAPTER AND RETAINING COLLAR.

- 4** Place Handle Spacer (1) onto the Valve (2). Ensure it is properly aligned as shown below and seated onto the trim.

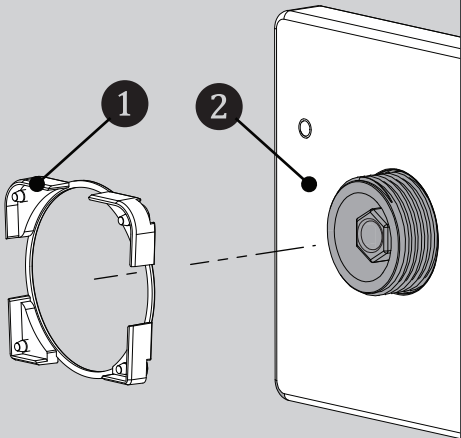

- 5** Confirm that the Valve is in the Vertical position. Thread the Handle Adapter and Retaining Collar (1) onto the Mounting Base (2). Take care to align the Wall Plate as shown below. Lock it into place. Hand tighten until snug.

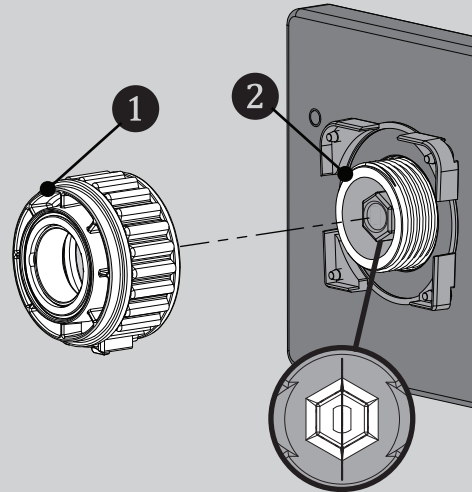

* VALVE IN VERTICAL POSITION

- 6** Ensure the Handle Adapter and Retaining Collar (1) are in a perfectly vertical position with the Snap located at the bottom. Align the HEX Spindle (2) with the HEX drive (3) of the Handle Assembly. Keep Handle in a stationary vertical position as you snap the Handle Hub (4) on to the Mounting Base. Ensure the Snap is fully seated in the hole and that the Handle Spacer is properly aligned and seated into the handle.

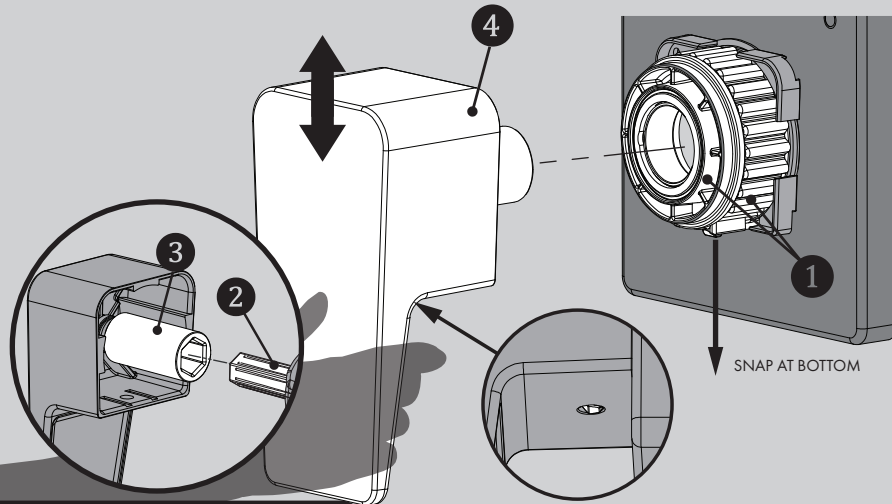

SNAP AT BOTTOM

* VIEW FROM UNDER THE HANDLE ASSEMBLY. MOUNTING BASE AND WALL PLATE NOT SHOWN.

* VIEW FROM UNDER THE HANDLE ASSEMBLY.

CPT-1124 ROUGH-IN DIAGRAM

SPEAKMAN®

NOTES:

COMPLIANCE:

ASME A 112.18.1 / CSA B 125.1
ADA COMPLIANT 

Contractor to supply necessary inlet connections.

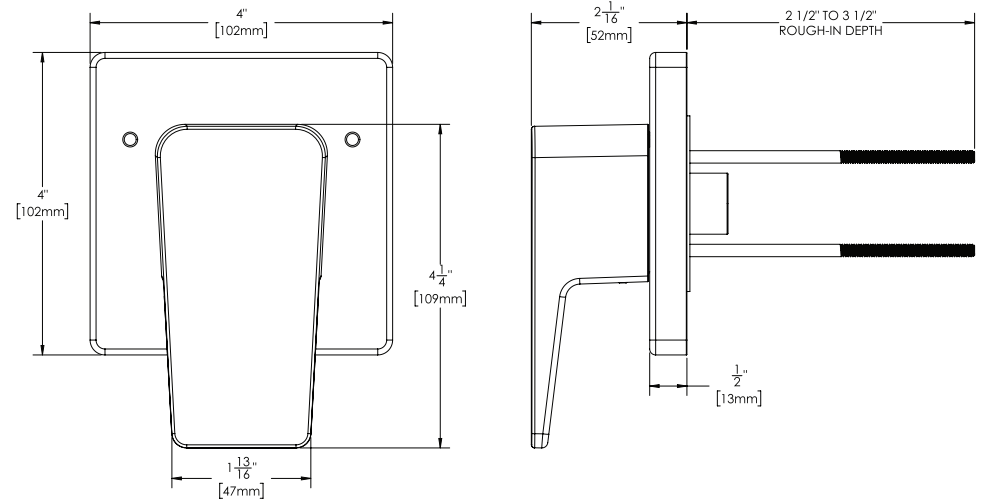

DIMENSIONS SUBJECT TO CHANGE WITHOUT NOTICE.