

# INSTRUCTION MANUAL

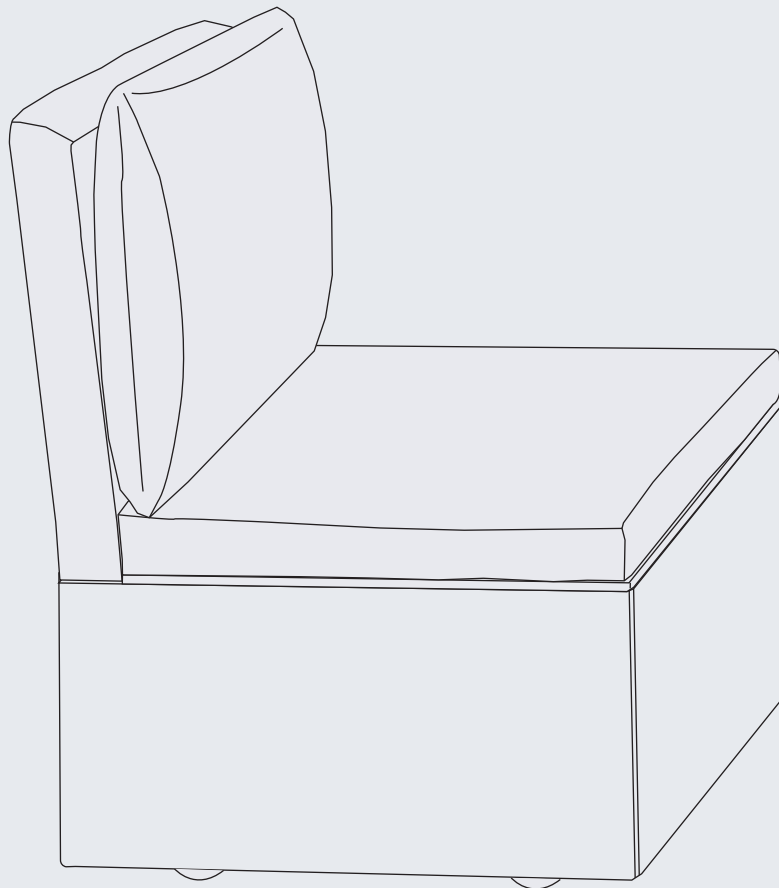

Chenille Upholstered Dining Chair  
With Storage With Casters

V1.0

## ! CARE & MAINTENANCE

### Please keep this instruction for your future reference.

- Be careful when assembly, avoid hurting the top surface.
- Clean the chair with lukewarm water, mild detergent & soft cloth.
- Firmly secure all bolts before use, do not use any part of this item as a step ladder.
- Reconfirm that all bolts, screws, and nuts are secure every 90 days.
- Do not use or store this item in the proximity of open flame or flammable/combustible chemicals.
- Be aware that some parts are heavy and have sharp edges.
- Do not overtighten screws. (Insert all screws before tighten screws.)
- Please do not exceed the weight limitations of this item.

## TOOLS REQUIRED

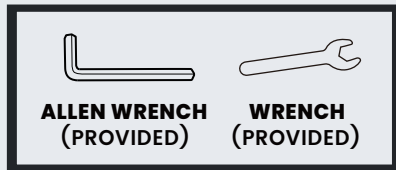

**LBS**  
CHAIR  
300 LBS  
CAPACITY



**1 PERSON**  
ASSEMBLY



**UP TO 20 MIN.**  
ASSEMBLY

## HARDWARE

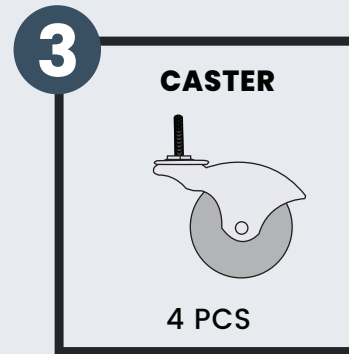
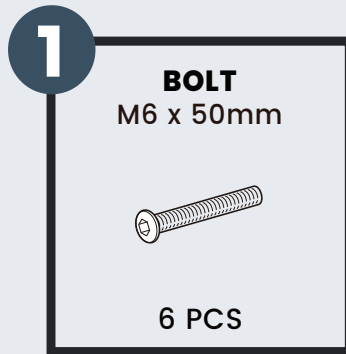

## PARTS

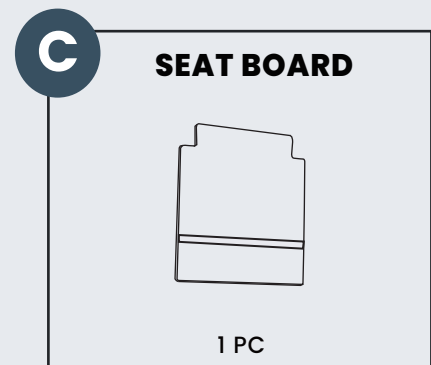
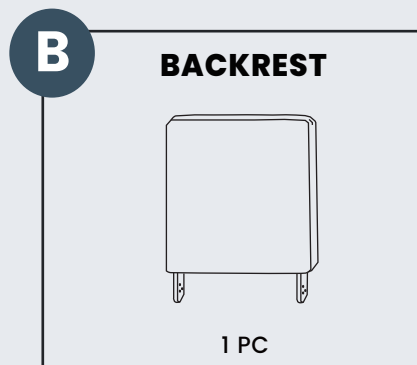
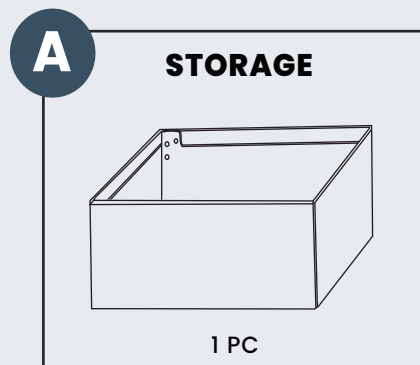

## PARTS

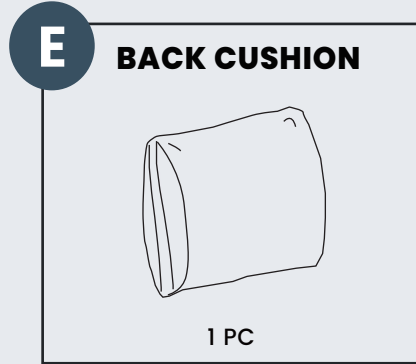
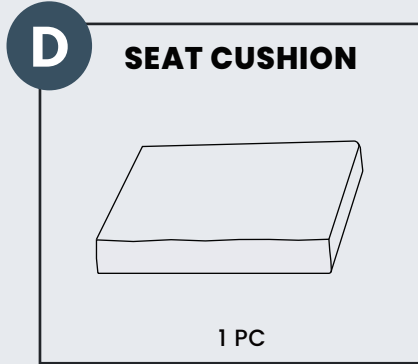

## PRODUCT ASSEMBLY - OVERALL VIEW

Look at following overall view of this chair and learn the exact position of each parts to be assembled.

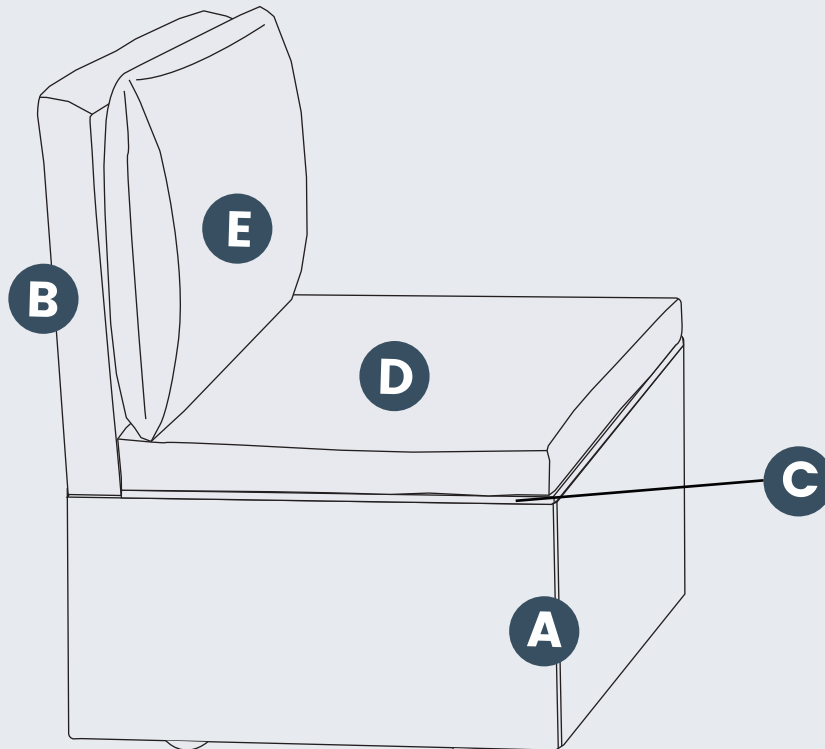

## PRODUCT ASSEMBLY

1

Place **Part A Storage** upside down onto flat surface.

Attach 4 pcs of **Hardware #3 Casters** to **Part A Storage**.

Tighten the casters by the wrench provided.

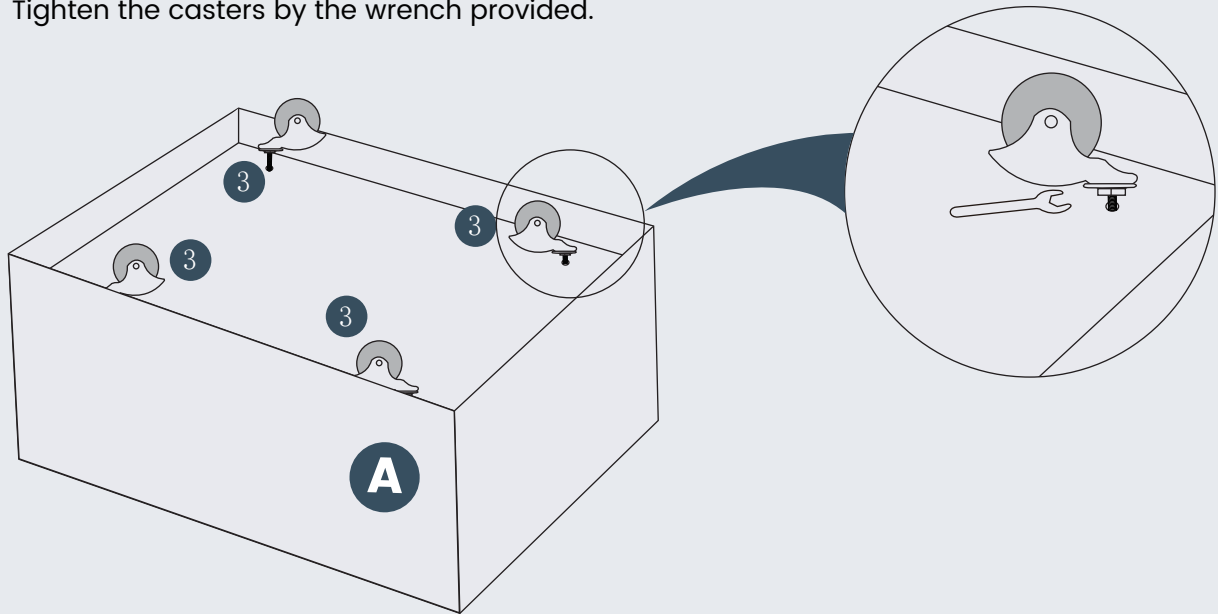

2

Place **Part B Backrest** and **Part A Storage** as below and attach them with 6 sets of **Hardware #1 Bolt, #2 Washer**.

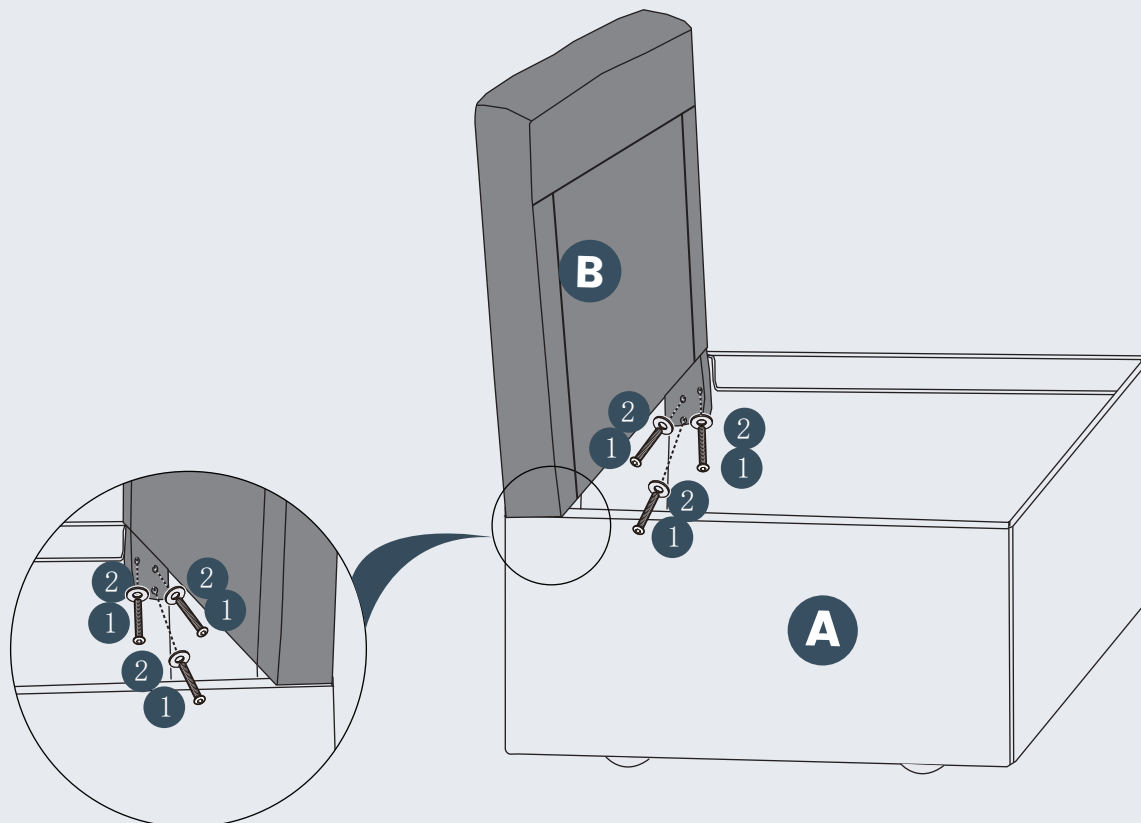

## PRODUCT ASSEMBLY

3

Place **Part C Seat Board** onto **Part A Storage** as below.

Tilt the **Seat Board** up when storage is in use.

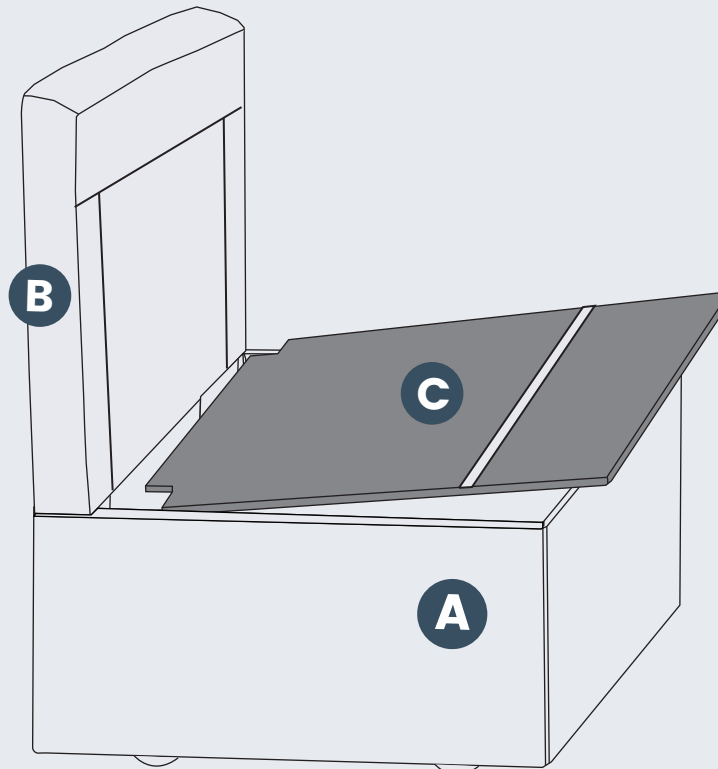

4

Place the cushions onto the chair for comfortable use.

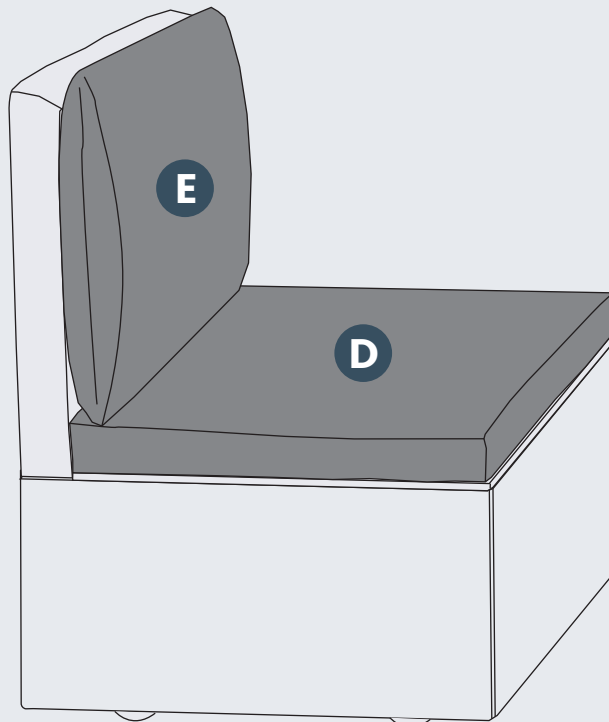

---

## CLEANING TIPS

**REGULAR CLEAN:** Use a mixture of warm water and mild soap. Gently scrub the surface with a soft bristle brush to remove any dirt or stains.

**QUICK CLEAN:** You can simply wipe down the furniture with a damp cloth.

Regular cleaning not only preserves the aesthetic appeal of your furniture, but also helps extend its lifespan.