

<b>SIDES</b>	<b>BOTTOM</b>
12 1/2"-3/4" MOON KNOCKOUTS	8 KNOCKOUTS
	8 1/2"-3/4" MOON KNOCKOUTS
Material: Steel-0.0625"-G60 Galvanized	

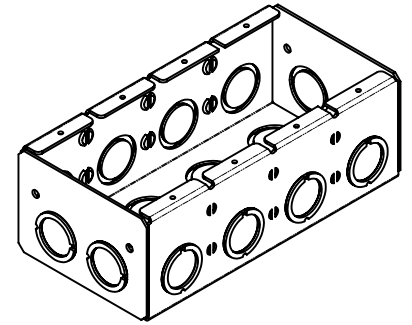

8 1/2"-3/4" MOON KNOCKOUTS  $\phi = 22.50$  [ $\phi = 0.886$ ]  
 $\phi = 28.50$  [ $\phi = 1.122$ ] MIRROR

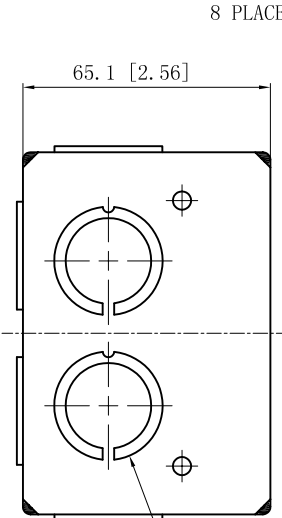
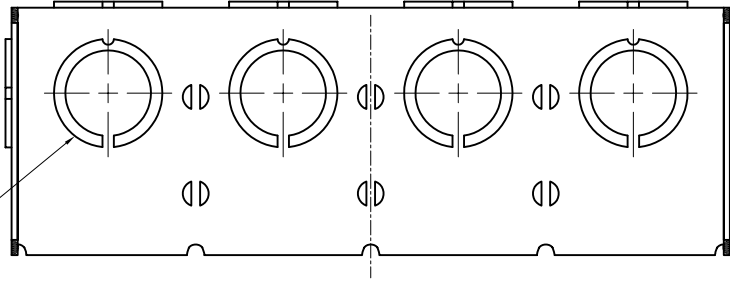

8 PLACES SPOT WELDING

65.1 [2.56]

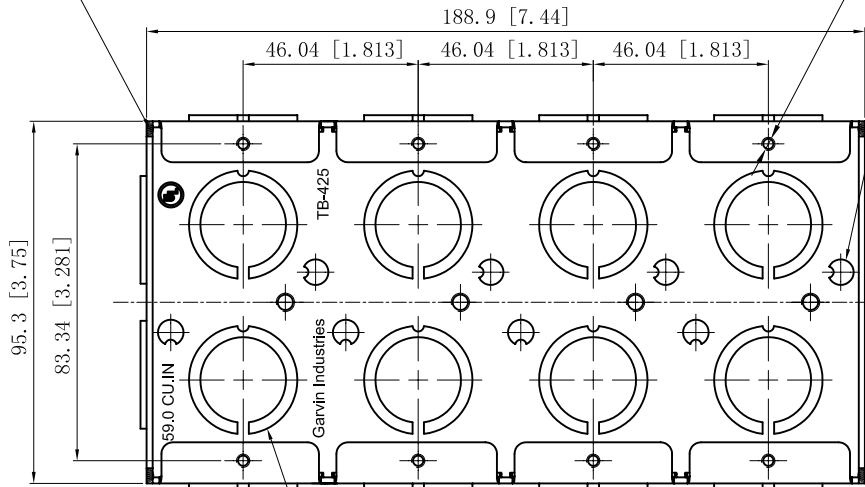

188.9 [7.44]

46.04 [1.813] 46.04 [1.813] 46.04 [1.813]

8-#6-32 UNC HOLE

8 KNOCKOUTS  $\phi = 6.75$  [ $\phi = 0.266$ ]

95.3 [3.75]  
83.34 [3.281]

8 1/2"-3/4" MOON KNOCKOUTS  $\phi = 22.50$  [ $\phi = 0.886$ ]  
 $\phi = 28.50$  [ $\phi = 1.122$ ]

4 1/2"-3/4" KNOCKOUTS  $\phi = 22.50$  [ $\phi = 0.886$ ]  
 $\phi = 28.50$  [ $\phi = 1.122$ ] MIRROR

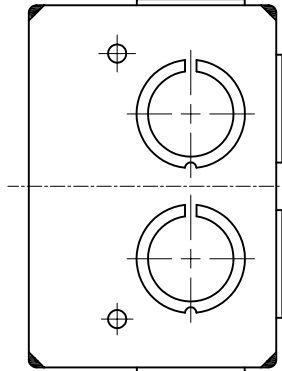

<b>DESCRIPTION</b>
<b>TRADE REFERENCE TERMS</b>

This data sheet is for reference only .GARVIN INDUSTRIES reserves the right to make changes to the design without prior notice.

<b>STANDARD PACKING</b>
5 PCS

<b>GARVIN INDUSTRIES</b>		
TITLE SOLID MASONRY BOX 2-1/2" DEEP		
SIZE A4	DWG NO. TB-425	REV A
DATA SHEET		