

FORESTVIEW II PLAYHOUSE
MAISONNETTE FORESTVIEW II
CASA DE JUEGOS FORESTVIEW II

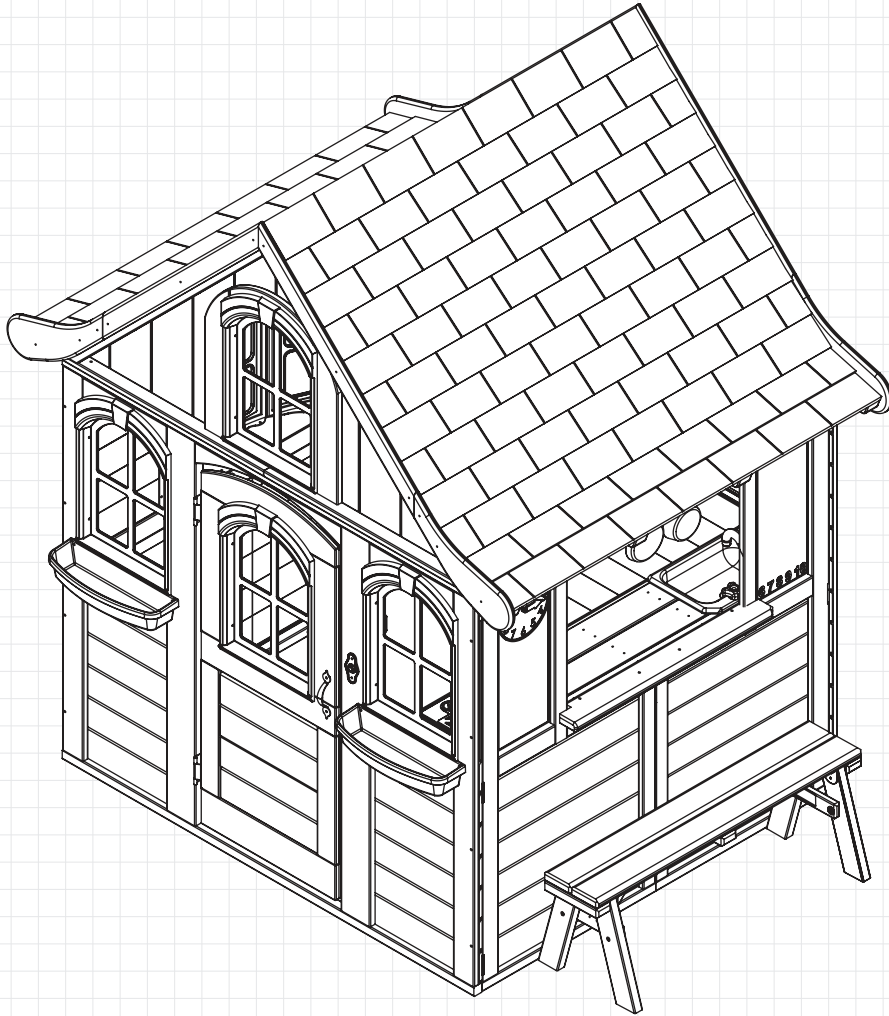

CALL US OR GO ONLINE
APPELÉZ-NOUS OU ALLEZ EN LIGNE
LLÁMENOS O VISITE NUESTRO SITIO WEB



ASSEMBLY INSTRUCTIONS / INSTRUCTIONS D'ASSEMBLAGE / INSTRUCCIONES DE MONTAJE

**FOR 24/7 ONLINE PARTS REPLACEMENT / POUR LE
REPLACEMENT 24/7 DES PIÈCES EN LIGNE / PARA SOLICITUDES
ONLINE DE PIEZAS DE REPUESTO DE MANERA ININTERRUMPIDA**

parts.kidkraft.com

KidKraft, Inc.
4630 Olin Road
Dallas, Texas 75244
USA

customerservice@kidkraft.com

1.800.933.0771
972.385.0100

parts.kidkraft.eu

KidKraft Netherlands BV
Olympisch Stadion 8
1076 DE Amsterdam
The Netherlands

europecustomerservice@kidkraft.com

+31 20 305 8620
M-F from 09:00 to 17:30 (GMT+1)

BATCH CODE / CODE DE LOT / CÓDIGO DE LOTE

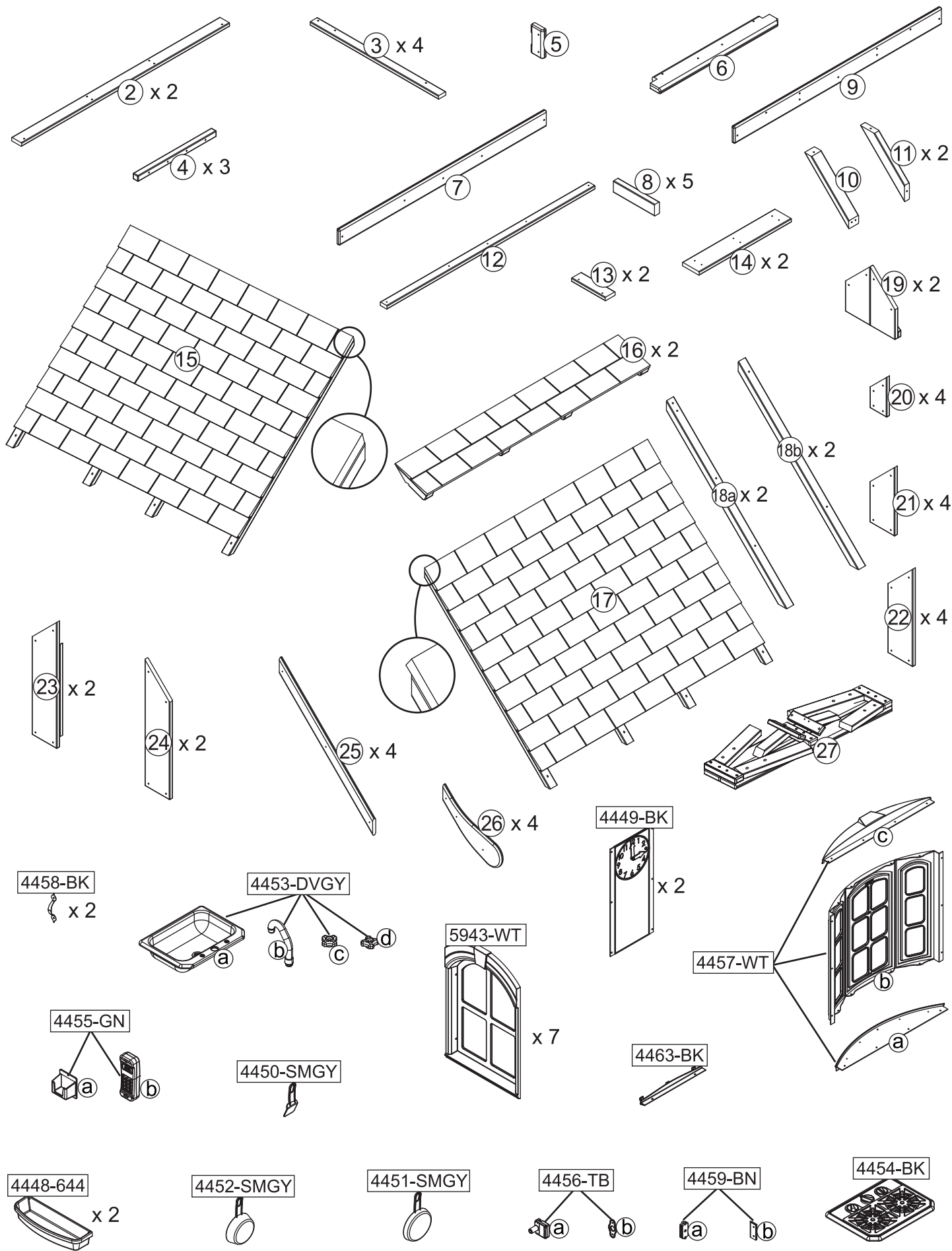

Parts and Hardware
Pièces et matériel
Partes y Piezas Para Instalación
Teile und Befestigungsmaterial
Parti e componenti meccanici

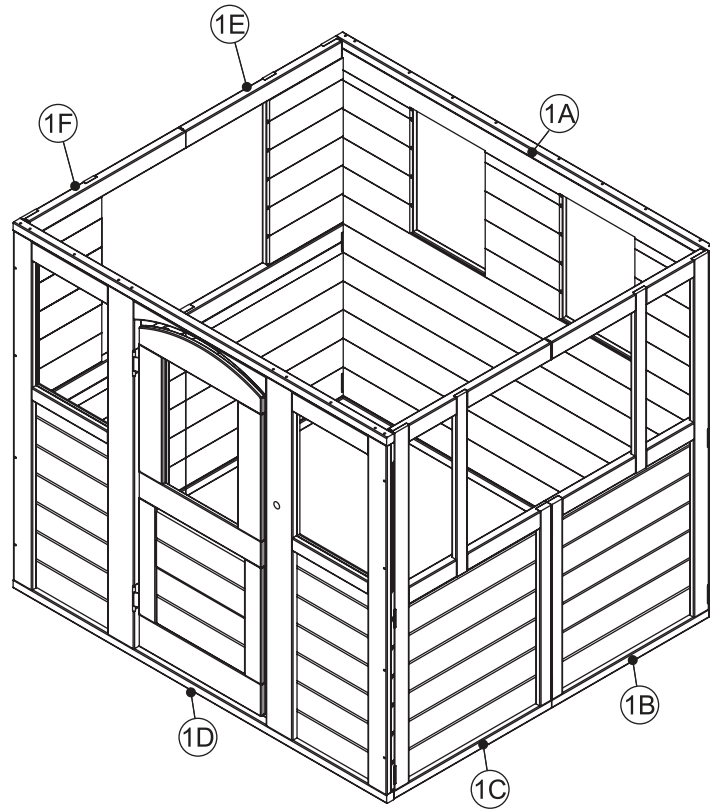

If you need to order parts,
please order below part#

Si necesita pedir piezas,
utilice el número de pieza
indicado a continuación
para realizar el pedido

Si vous avez besoin de
commander des pièces,
veuillez utiliser le numéro
de référence ci-dessous.

- P-20098-1A
- P-20098-1B
- P-20098-1C
- P-20098-1D
- P-20098-1E
- P-20098-1F
- P-20098-ZZ1
- 9326785
- 9326786
- 9326787

9326785 (4pcs)

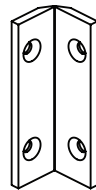

9326787 (10pcs)

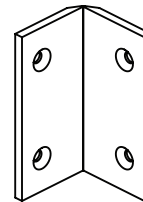

9326786 (4pcs)

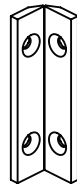



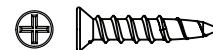







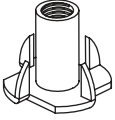

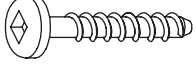
ZZ1(72PCS)

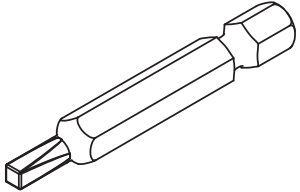

Parts and Hardware
Pièces et matériel
Partes y Piezas Para Instalación
Teile und Befestigungsmaterial
Parti e componenti meccanici

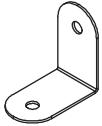
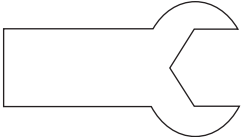
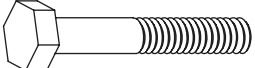
All hardware dimensions are approximate.
Toutes les dimensions du matériel
sont approximatives.
Todas las dimensiones de las herramientas
son aproximaciones.

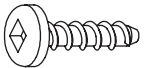
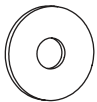
A x 76  32 mm	G x 4  25 mm	M x 4 
B x 51  44 mm	H x 49  28 mm	N x 10  9 mm
C x 44  38 mm	I x 8 	x 1 
D x 6  62 mm	J x 2 	x 1 
E x 4  42 mm	K x 4 	
F x 78  16 mm	L x 4 	

Parts and Hardware
Pièces et matériel
Partes y Piezas Para Instalación
Teile und Befestigungsmaterial
Parti e componenti meccanici

All hardware dimensions are approximate.
Toutes les dimensions du matériel
sont approximatives.
Todas las dimensiones de las herramientas
son aproximaciones.



1

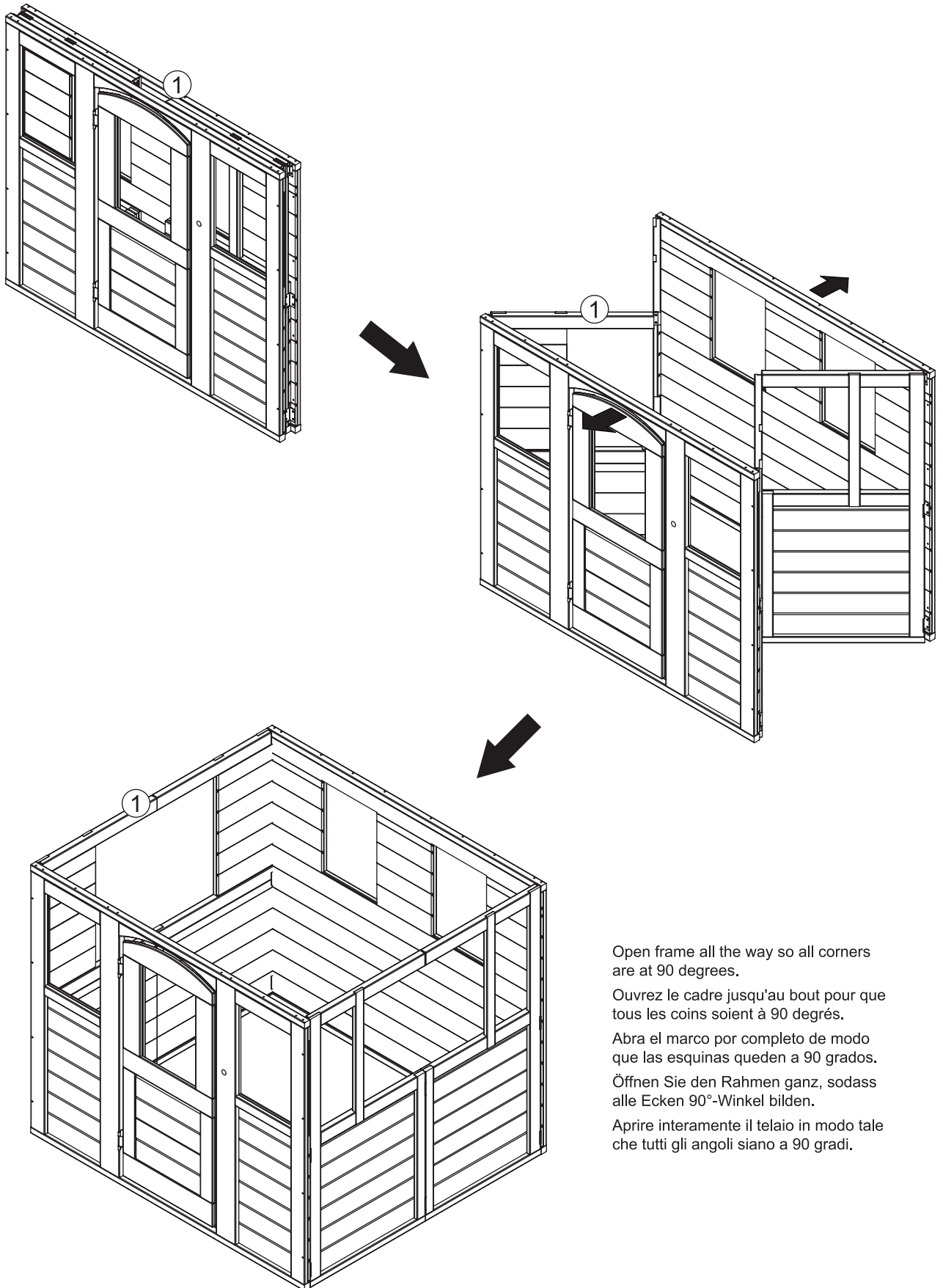

Open frame all the way so all corners are at 90 degrees.

Ouvrez le cadre jusqu'au bout pour que tous les coins soient à 90 degrés.

Abra el marco por completo de modo que las esquinas queden a 90 grados.

Öffnen Sie den Rahmen ganz, sodass alle Ecken 90°-Winkel bilden.

Aprire interamente il telaio in modo tale che tutti gli angoli siano a 90 gradi.

Step
Étape
Paso
Schritt
Fase

2

2 x ②

8 x C

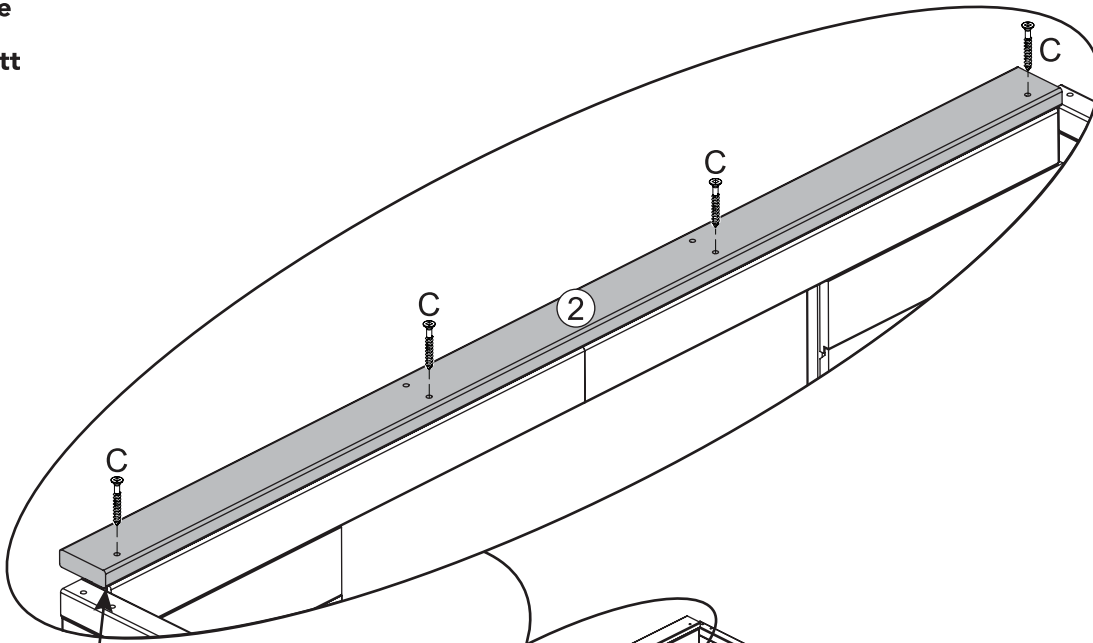

Flush
Aligné
A ras
Bündig
A filo

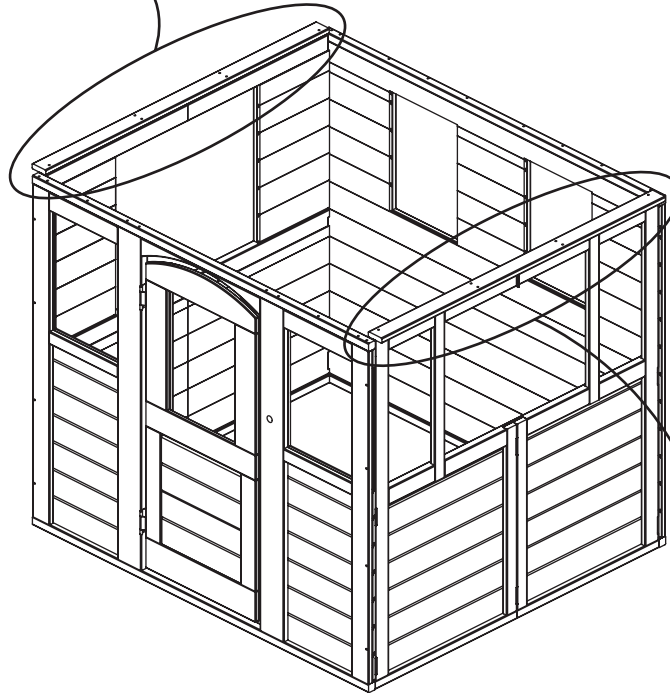

Flush
Aligné
A ras
Bündig
A filo

Flush
Aligné
A ras
Bündig
A filo

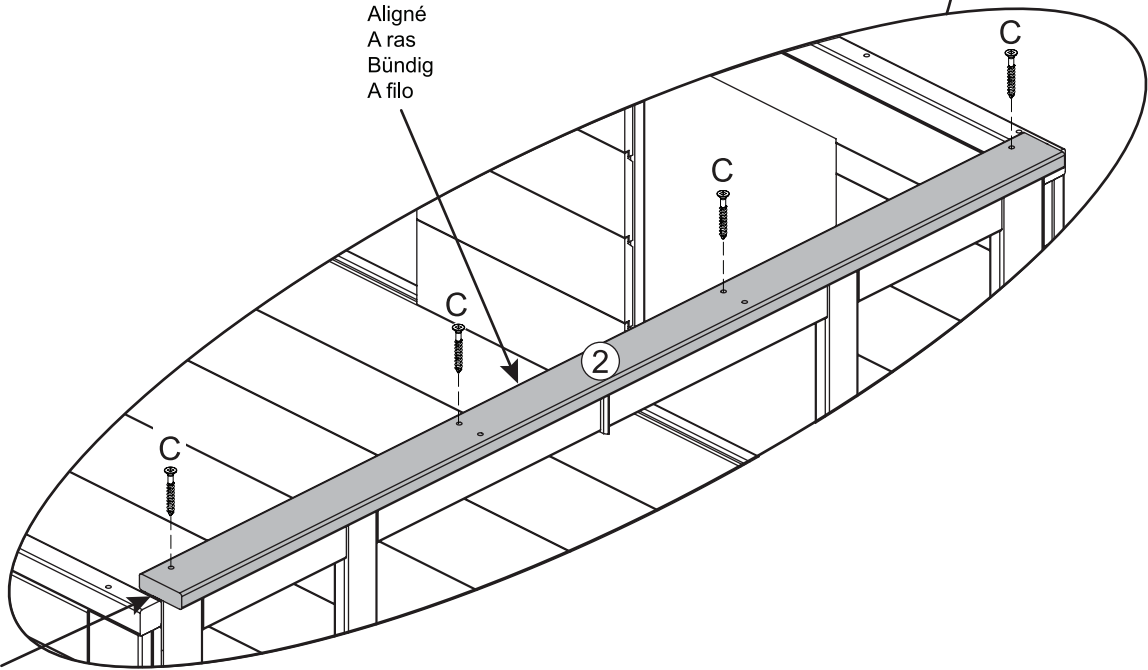

Step
Étape
Paso
Schritt
Fase

3

Do not use this hole, leave it until future step
 Ne vous servez pas de ce trou, oubliez-le jusqu'à la prochaine étape
 No use este orificio, resérvelo para más adelante
 Diese Bohrung nicht verwenden, wird in einem späteren Schritt benötigt
 Non utilizzare questo foro, lasciarlo per una fase successiva

4 x **3**

8 x **C**

Note Hole Orientation
 Notez l'orientation des trous
 Tenga en cuenta la orientación de los orificios
 Lochausrichtung beachten
 Annotare l'orientamento del foro

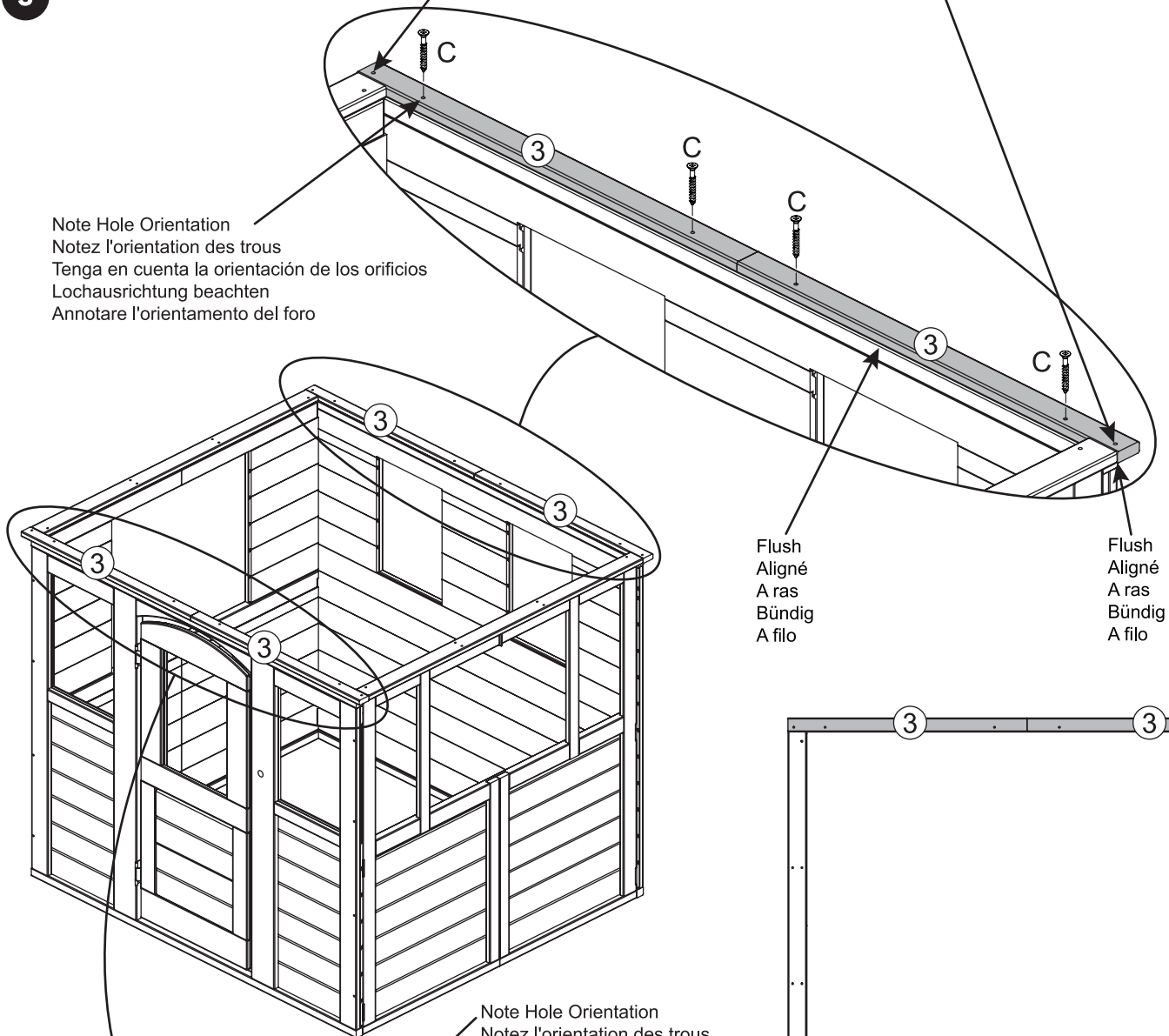

Flush
Aligné
A ras
Bündig
A filo

Flush
Aligné
A ras
Bündig
A filo

Note Hole Orientation
 Notez l'orientation des trous
 Tenga en cuenta la orientación de los orificios
 Lochausrichtung beachten
 Annotare l'orientamento del foro

Flush / Aligné / A ras / Bündig / A filo

Do not use this hole, leave it until future step
 Ne vous servez pas de ce trou, oubliez-le jusqu'à la prochaine étape
 No use este orificio, resérvelo para más adelante
 Diese Bohrung nicht verwenden, wird in einem späteren Schritt benötigt
 Non utilizzare questo foro, lasciarlo per una fase successiva

Flush
Aligné
A ras
Bündig
A filo

Step
Étape
Paso
Schritt
Fase

4

2 x 4

8 x B

Flush
Aligné
A ras
Bündig
A filo

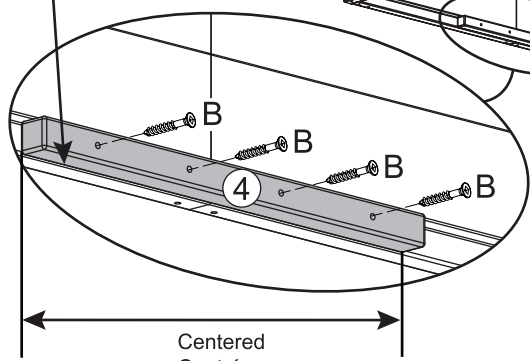

Centered
Centré
Centrado
Zentriert
Centrato

Centered
Centré
Centrado
Zentriert
Centrato

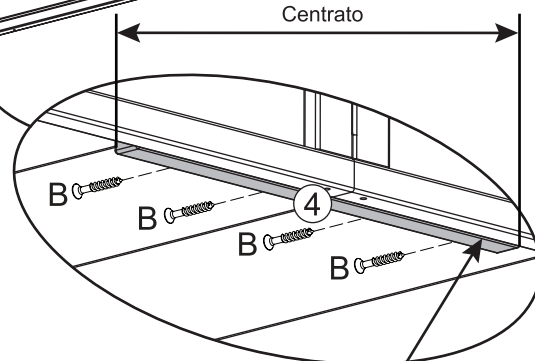

Flush / Aligné / A ras / Bündig / A filo

Step
Étape
Paso
Schritt
Fase

5

1 x 4458-BK

2 x F

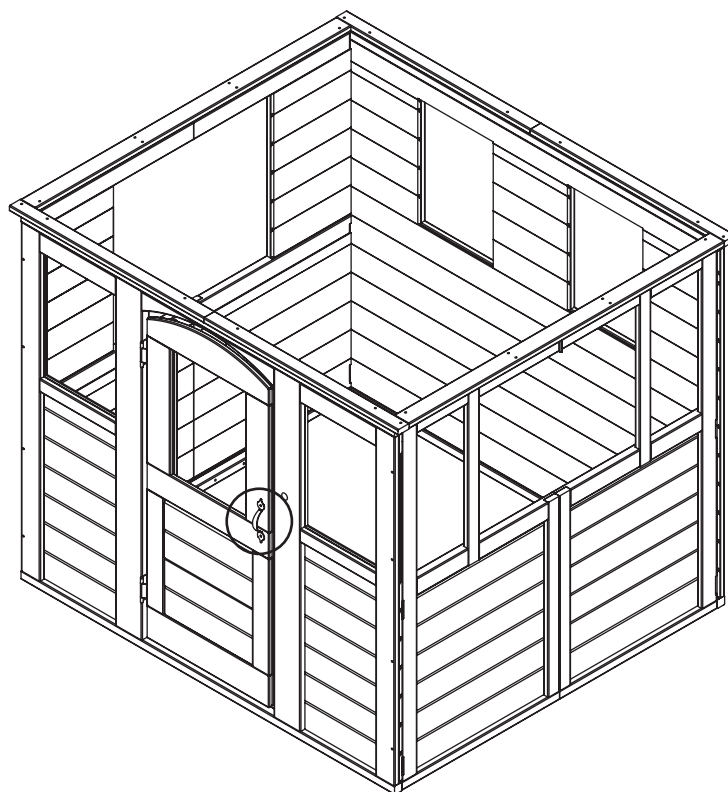
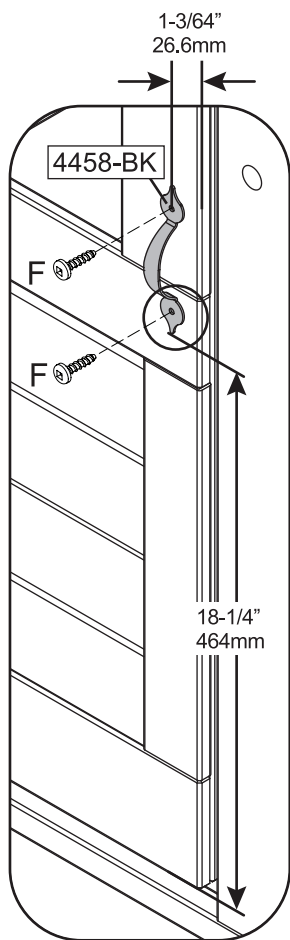

Step
Étape
Paso
Schritt
Fase

6

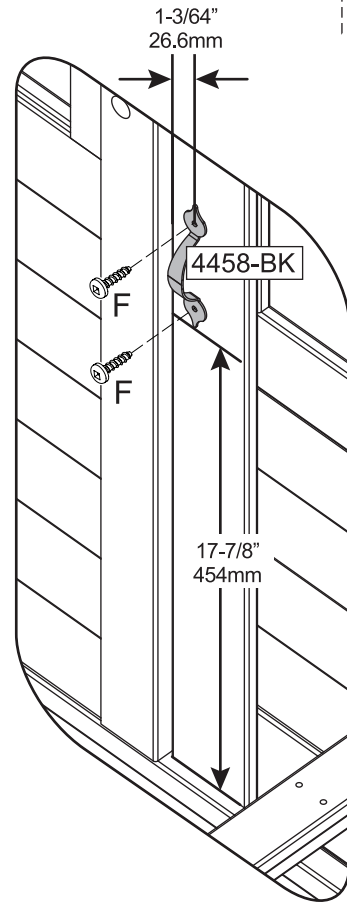
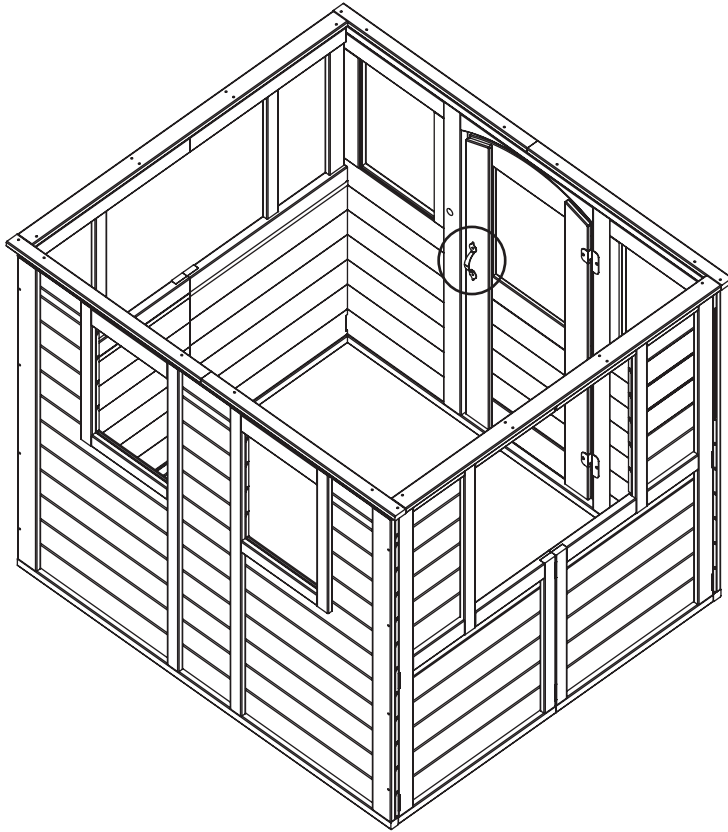

1 x 4458-BK

2 x F

Step
Étape
Paso
Schritt
Fase

7

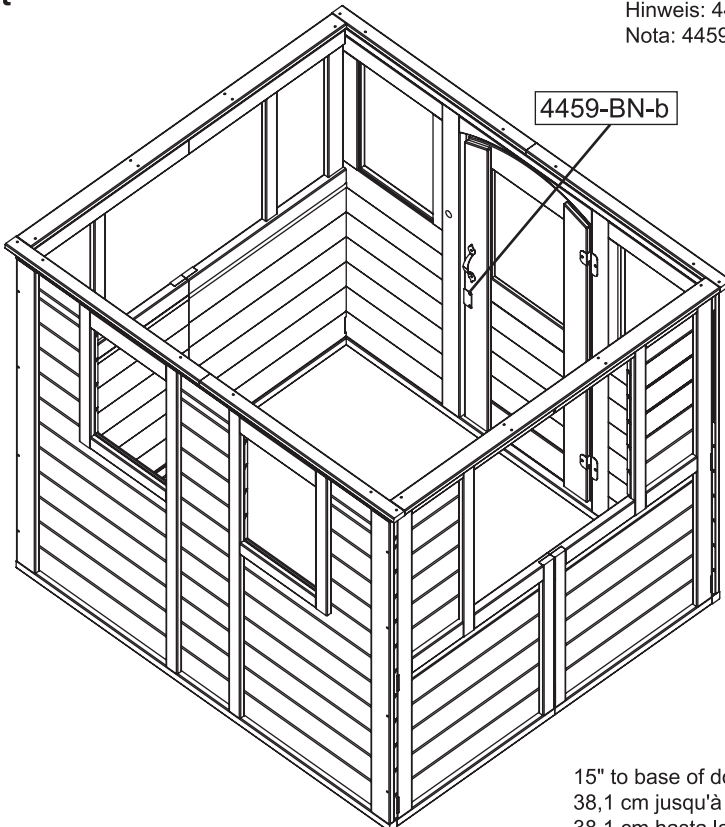

4459-BN-b

Note: 4459-BN-b is flush with door edge
Remarque : 4459-BN-b est aligné avec le bord de la porte
Nota: 4459-BN-b está a ras del borde de la puerta
Hinweis: 4459-BN-b liegt bündig an der Türkante an
Nota: 4459-BN-b è a filo del margine della porta

1 x 4459-BN-b

2 x F

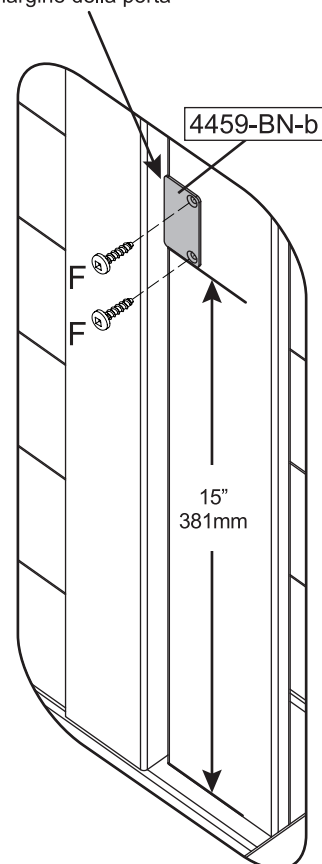

4459-BN-b

15" to base of door
38,1 cm jusqu'à la base de la porte
38,1 cm hasta la base del suelo
38,1 cm bis zur Türschwelle
381 mm fino alla base della porta

Step
Étape
Paso
Schritt
Fase

8

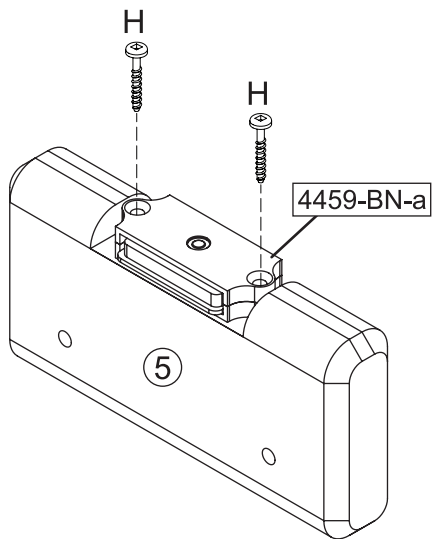

1 x ⑤

1 x 4459-BN-a

2 x H

Important: Use a hand held screw driver and DO NOT over tighten.

Important : Utiliser un tournevis manuel et ne PAS TROP serrer.

Importante: Use un destornillador de mano y no atornille en exceso.

Wichtig: Verwenden Sie einen Schraubenzieher und achten Sie darauf, die Schrauben NICHT zu fest anzuziehen.

Importante: usare un cacciavite a mano e NON serrare troppo.

Step
Étape
Paso
Schritt
Fase

9

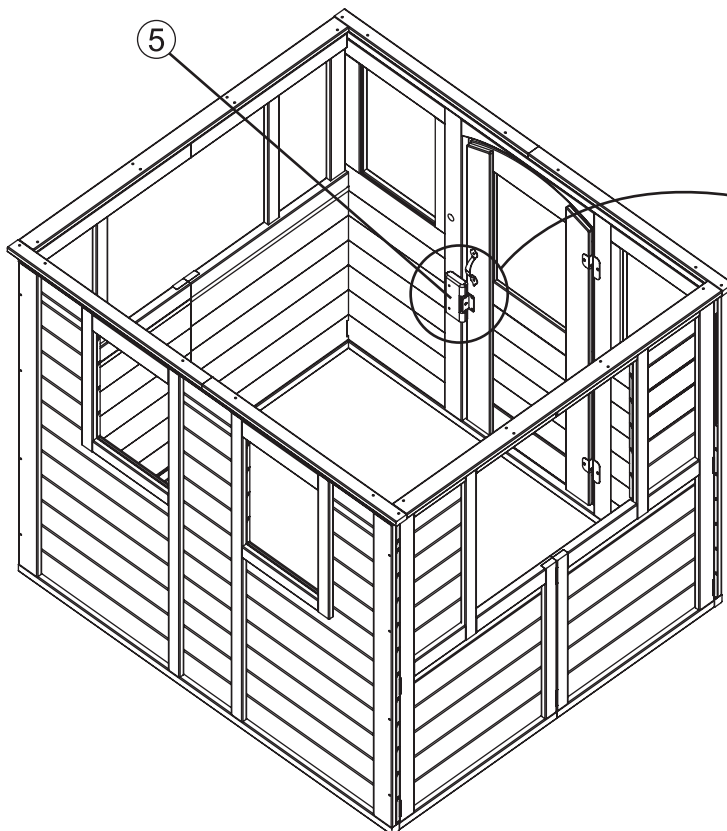

2 x C

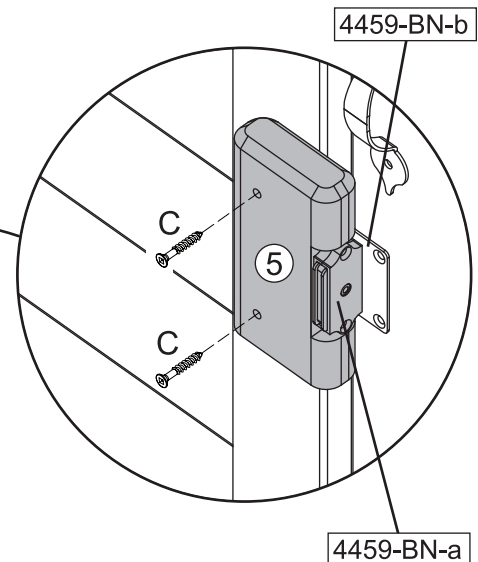

Note: Close door and vertically center 4459-BN-a to 4459-BN-b to assemble.

Remarque : Fermer la porte et centrer verticalement 4459-BN-a sur 4459-BN-b pour réaliser l'assemblage.

Nota: Cierre la puerta y centre verticalmente 4459-BN-a con 4459-BN-b para el montaje.

Hinweis: Zum Zusammenbauen die Tür schließen und 4459-BN-a vertikal an 4459-BN-b zentrieren.

Nota: chiudere la porta e centrare verticalmente da 4459-BN-a a 4459-BN-b per assemblare.

Step
Étape
Paso
Schritt
Fase

10

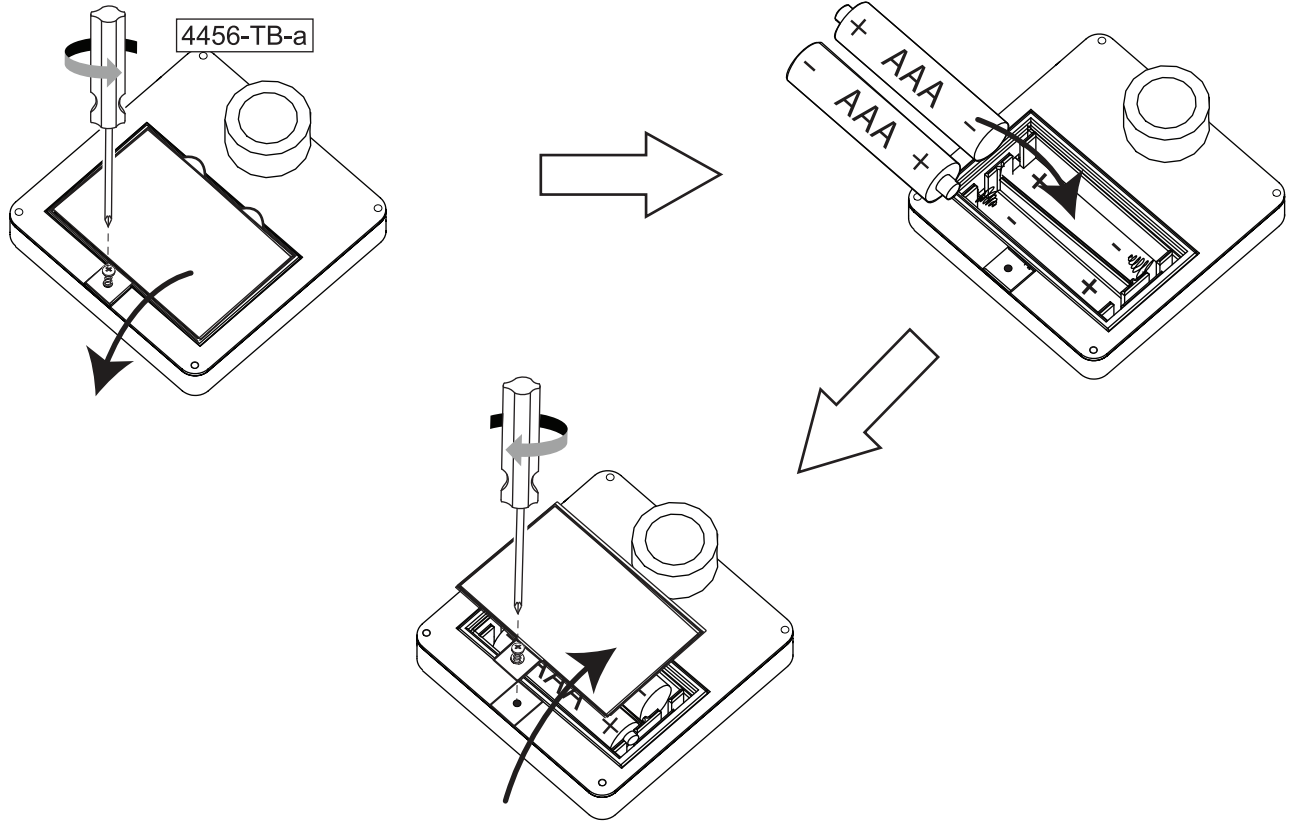

Step
Étape
Paso
Schritt
Fase

11

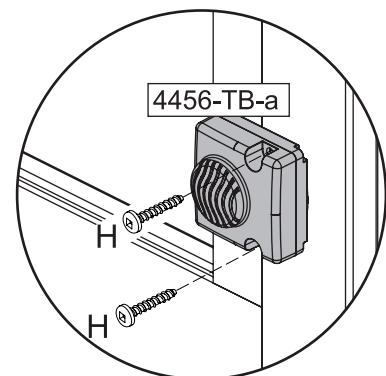
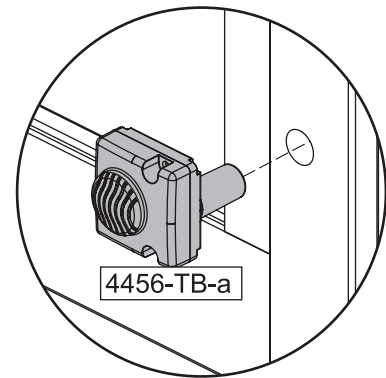
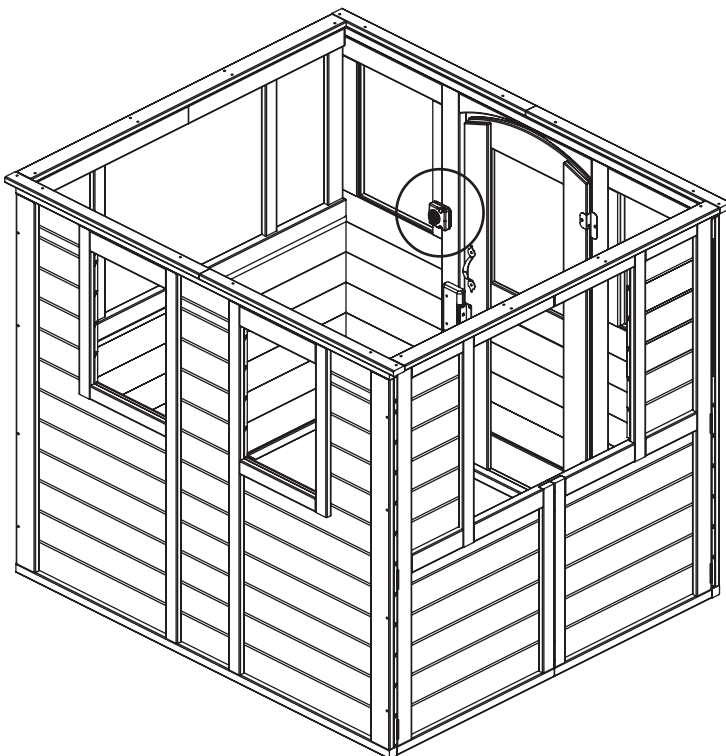

2 x H

Step
Étape
Paso
Schritt
Fase

12

1 x 4456-TB-b

2 x F

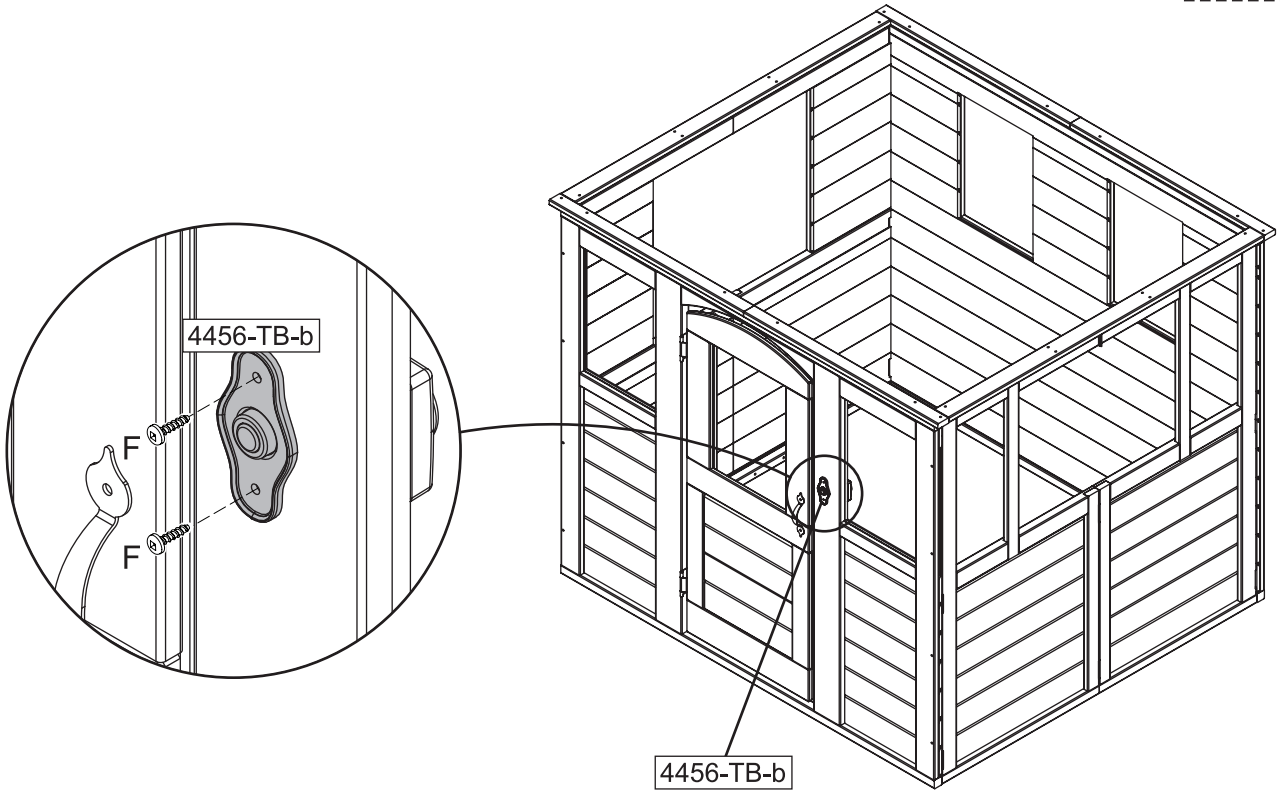

Step
Étape
Paso
Schritt
Fase

13

1 x 4455-GN

2 x F

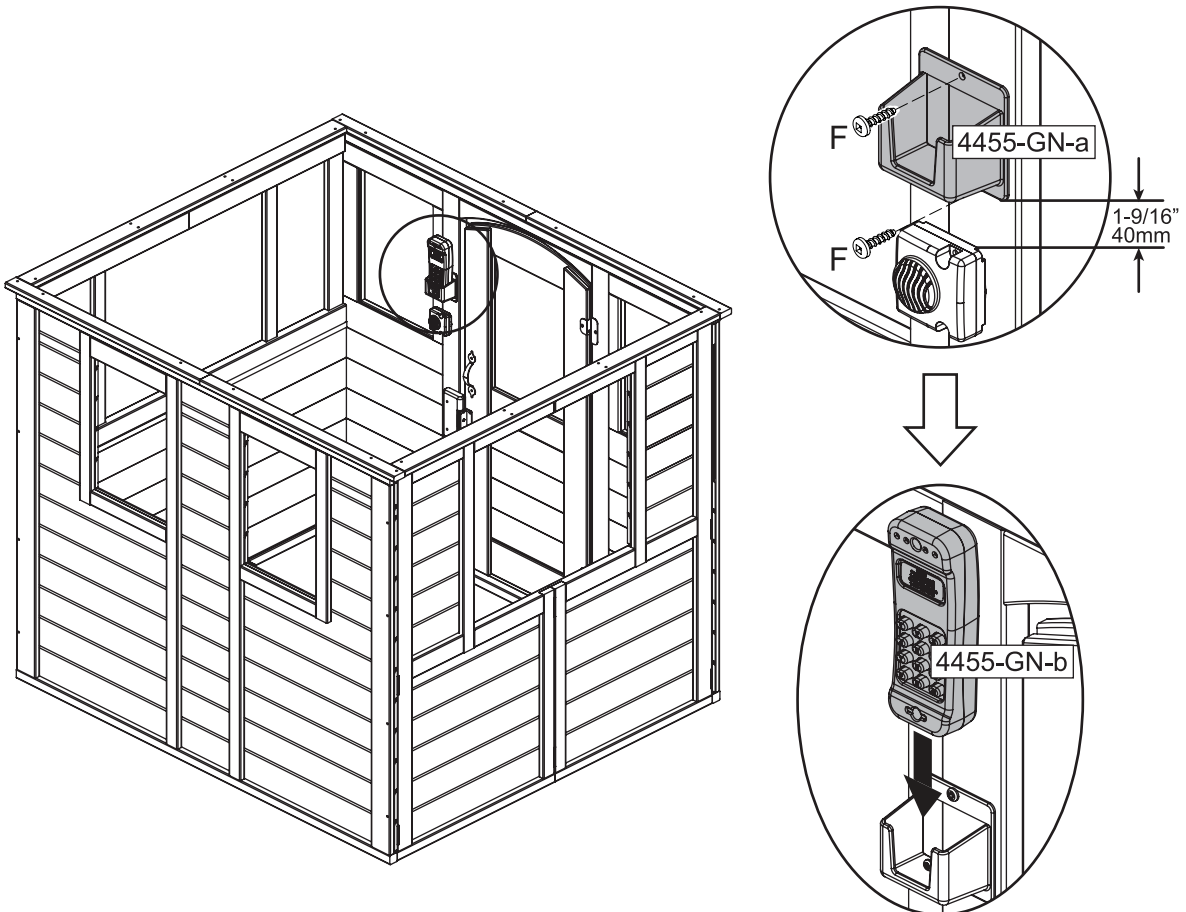

Step
Étape
Paso
Schritt
Fase

14

1 x ⑥

2 x B

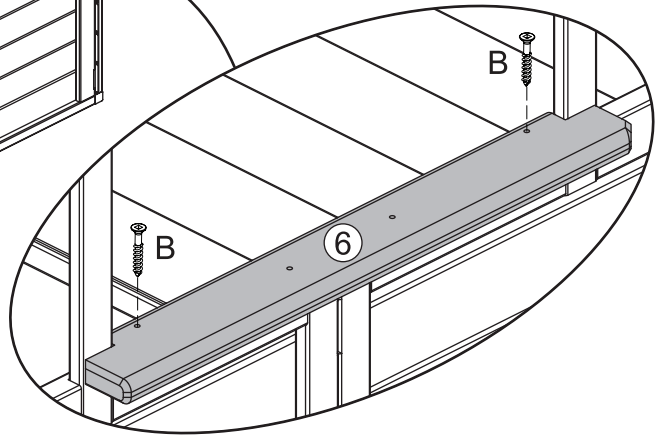
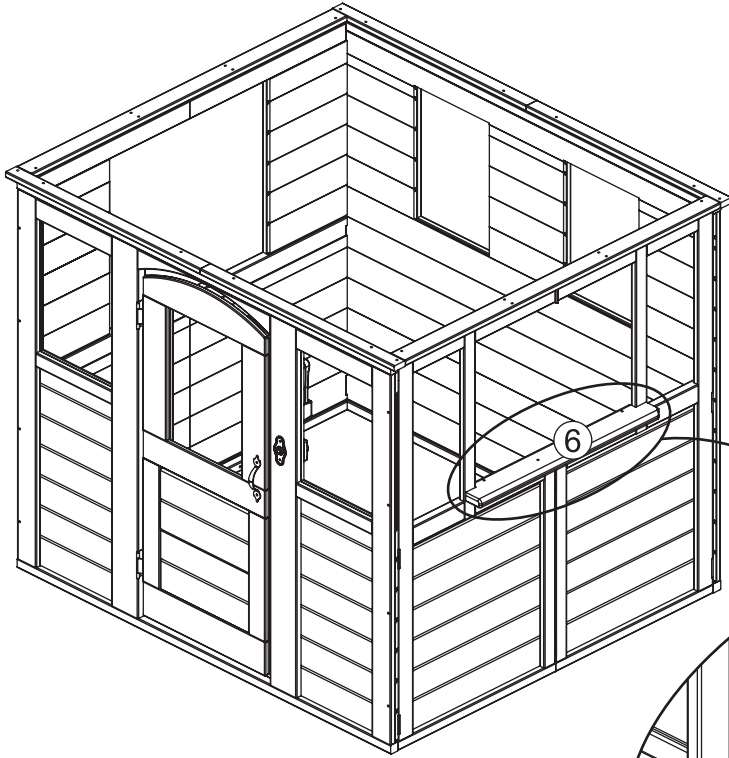

Step
Étape
Paso
Schritt
Fase

15

1 x ④

4 x B

Flush / Aligné / A ras / Bündig / A filo

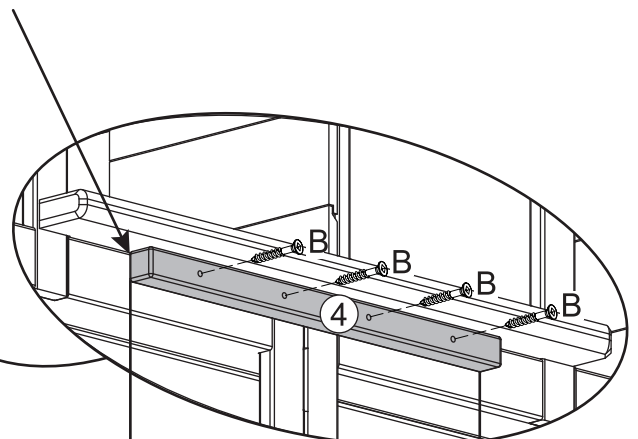
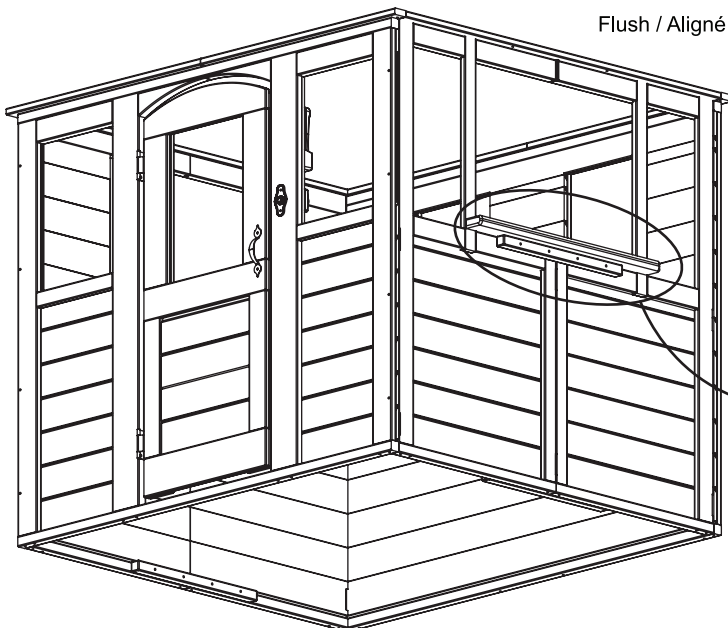

Centered
Centré
Centrado
Zentriert
Centrato

Step
Étape
Paso
Schritt
Fase

16

2 x B

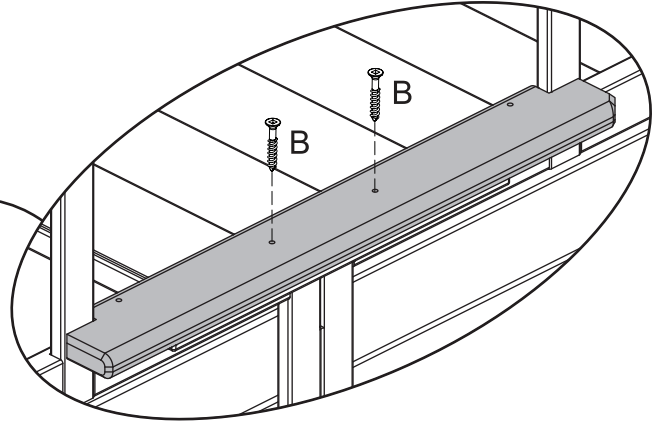
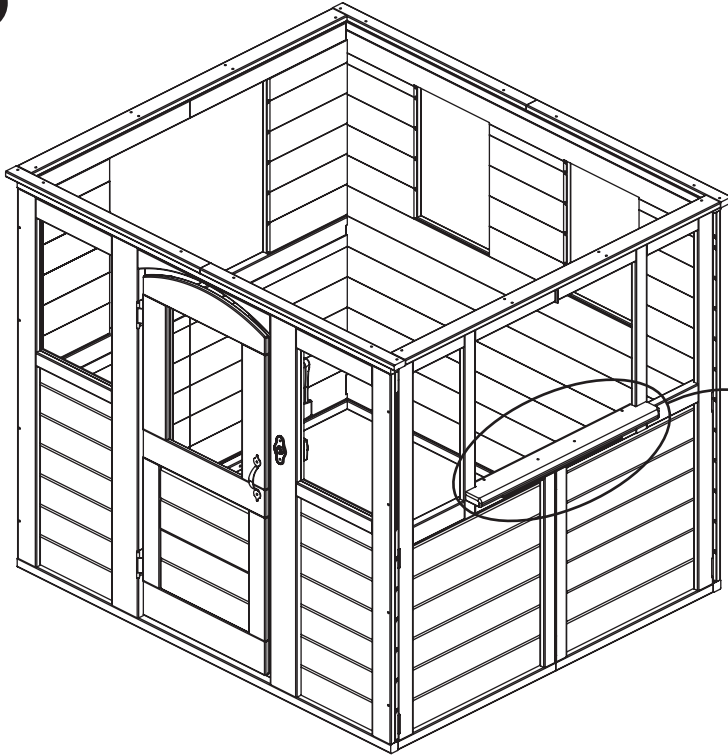

Step
Étape
Paso
Schritt
Fase

17

2 x 4449-BK

12 x F

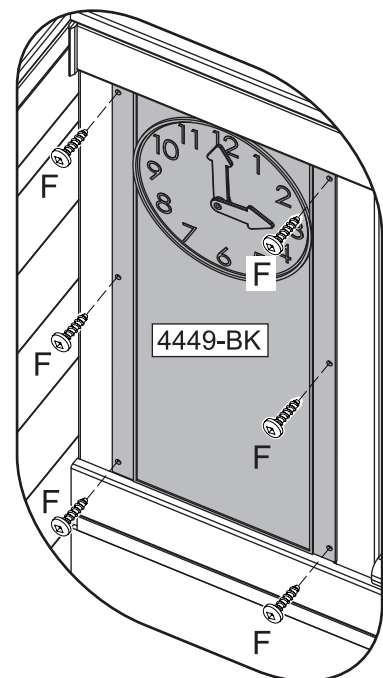
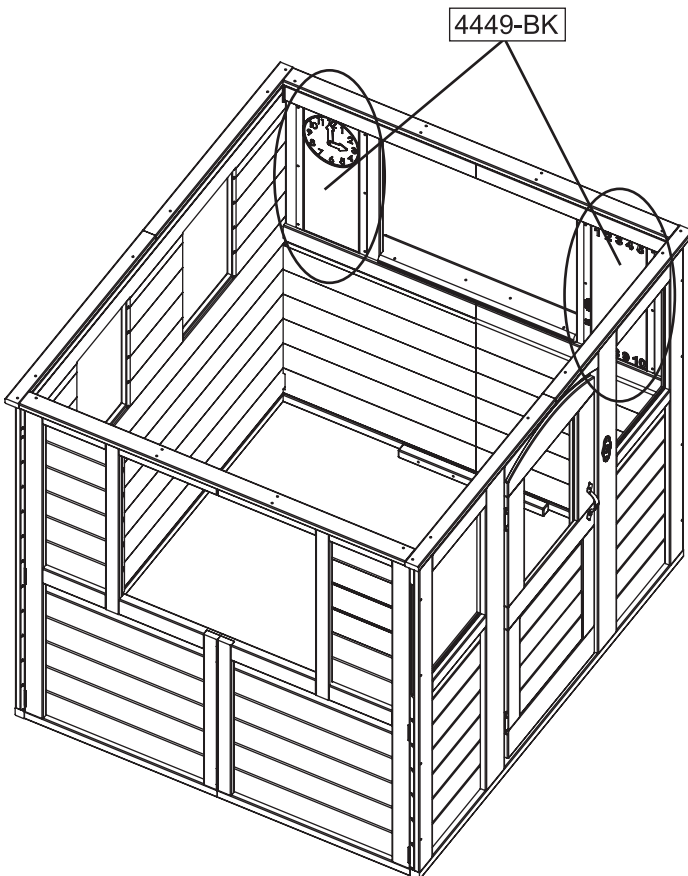

Step
Étape
Paso
Schritt
Fase

18

1 x 7

5 x 8

1 x 9

10 x C

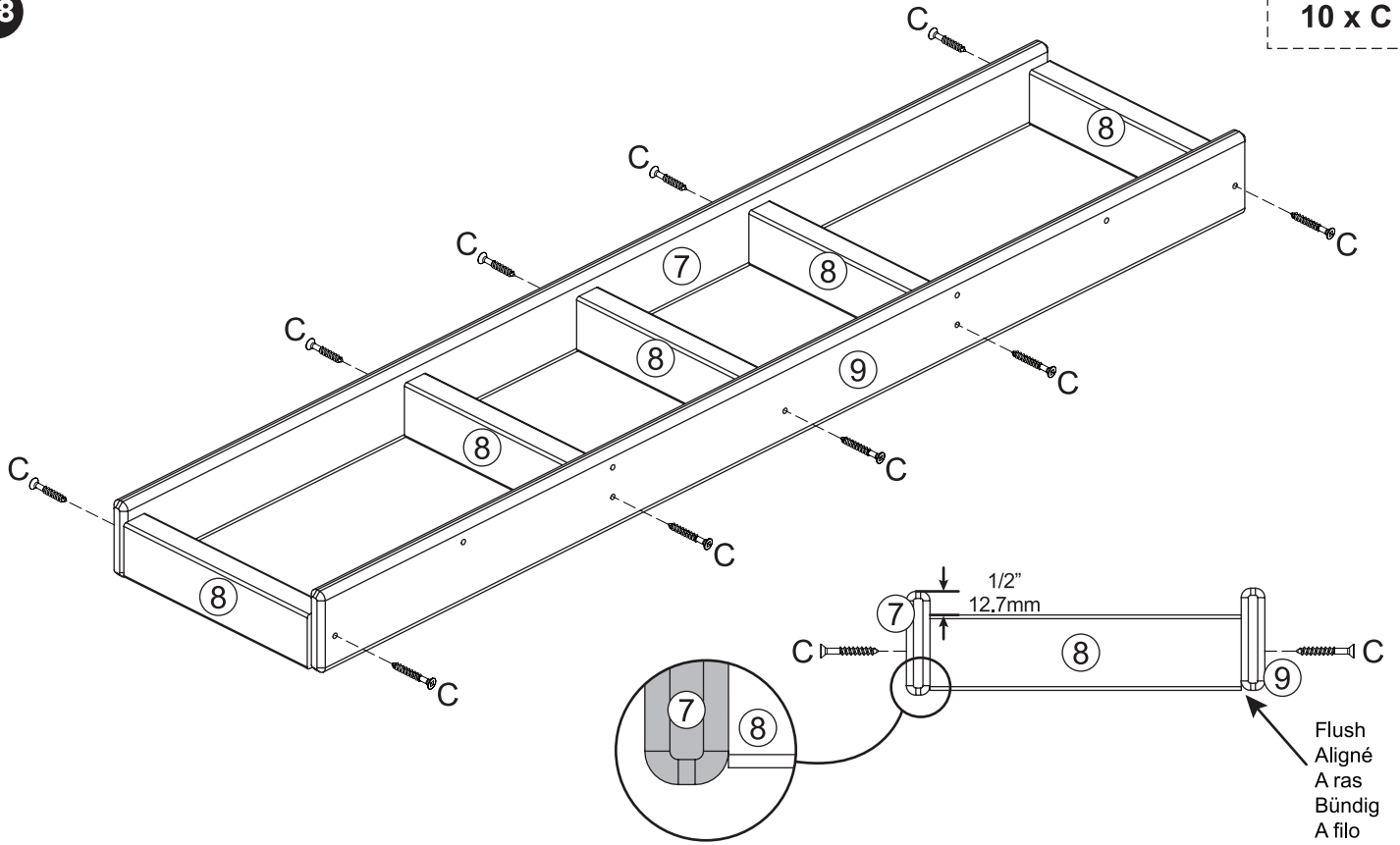

Step
Étape
Paso
Schritt
Fase

19

1 x 10

2 x 11

1 x B

2 x D

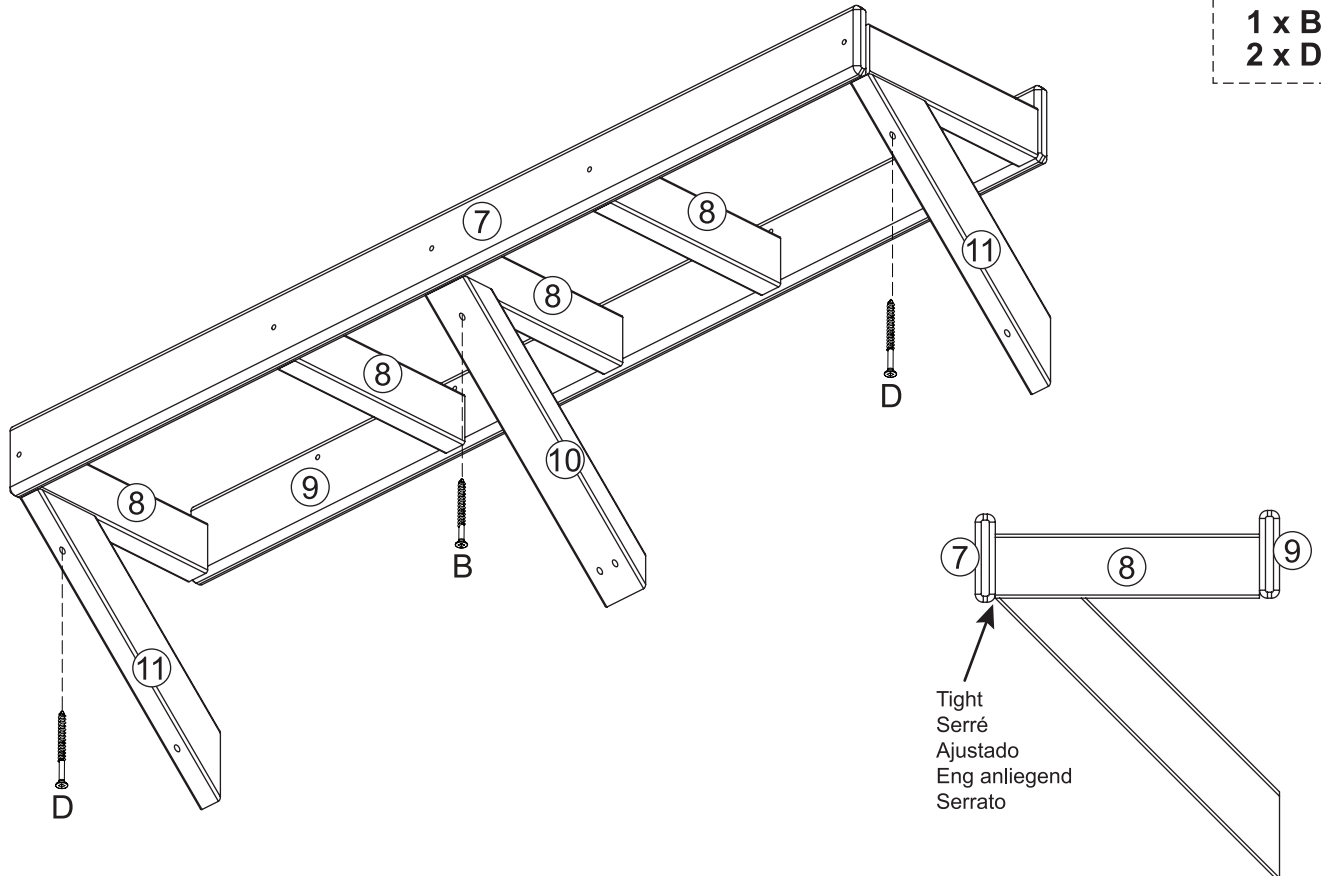

Step
Étape
Paso
Schritt
Fase

20



4 x A

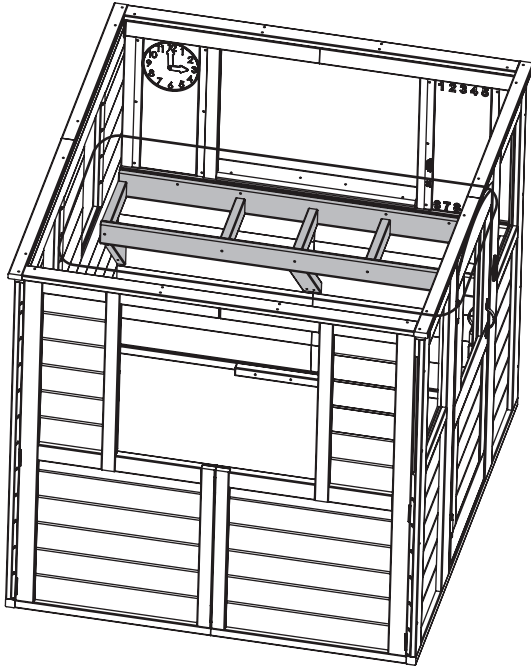
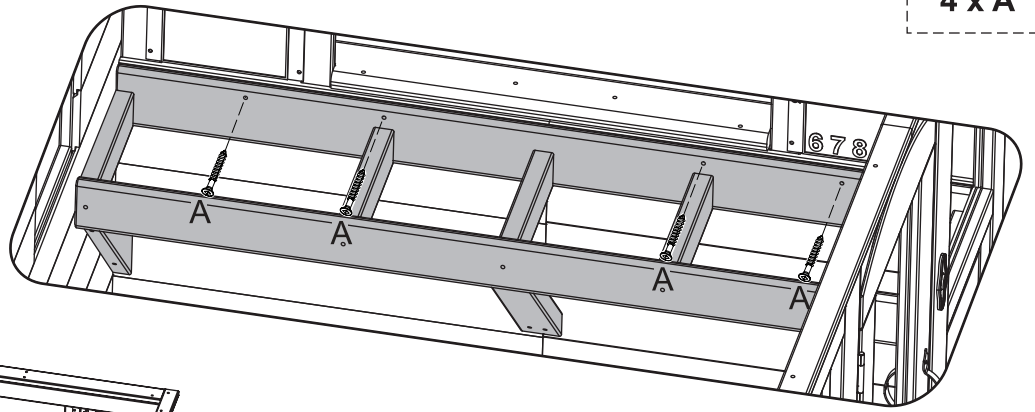

Step
Étape
Paso
Schritt
Fase

21

2 x B
2 x D

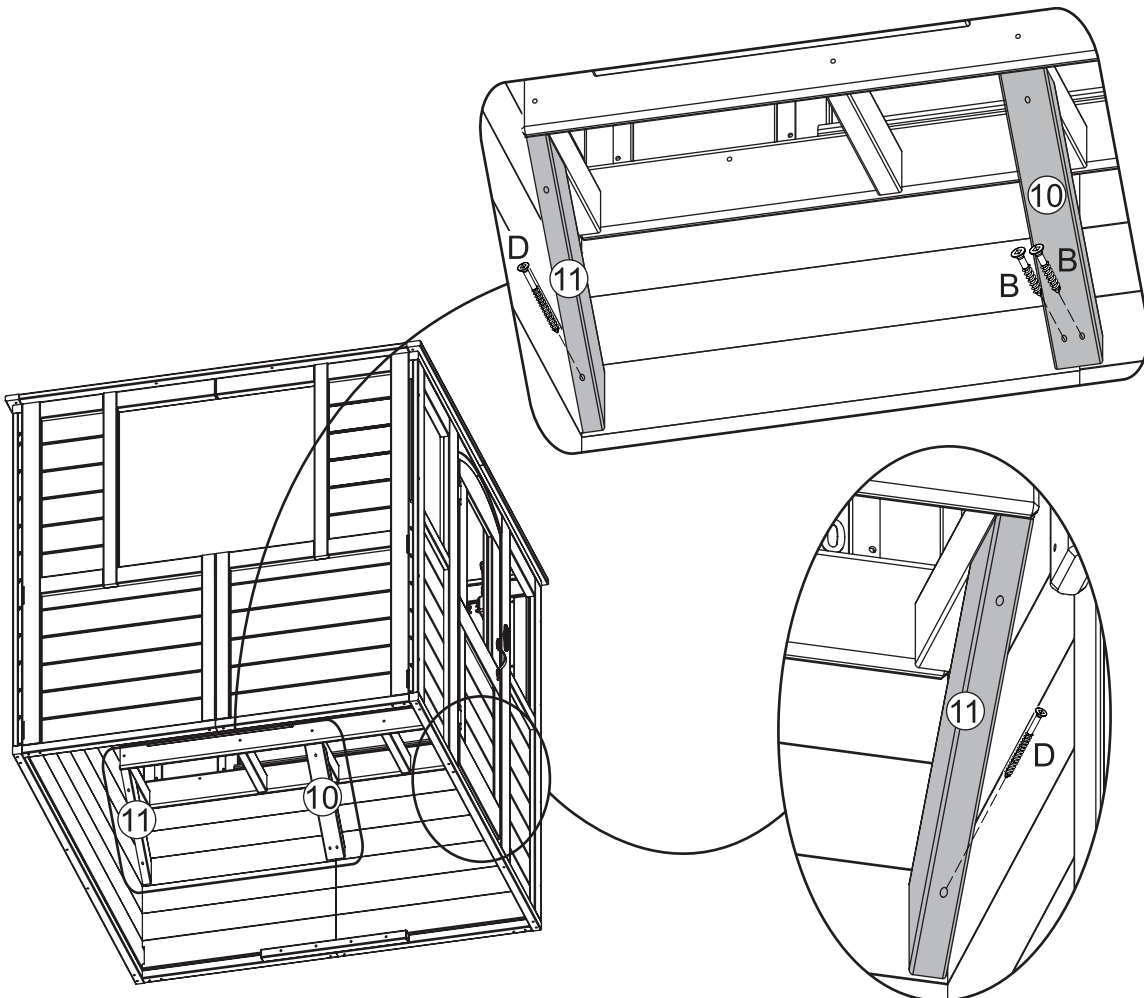

Step
Étape
Paso
Schritt
Fase

22

1 x 12

2 x 13

2 x 14

21 x H

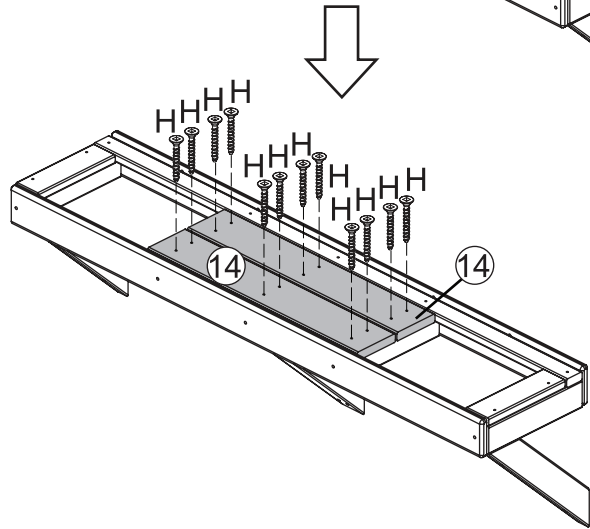
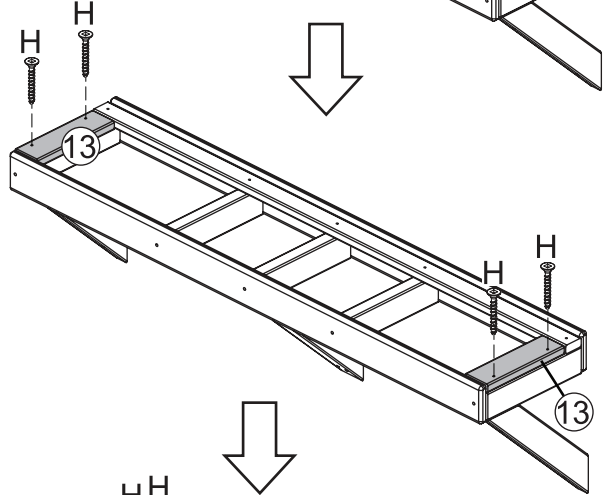
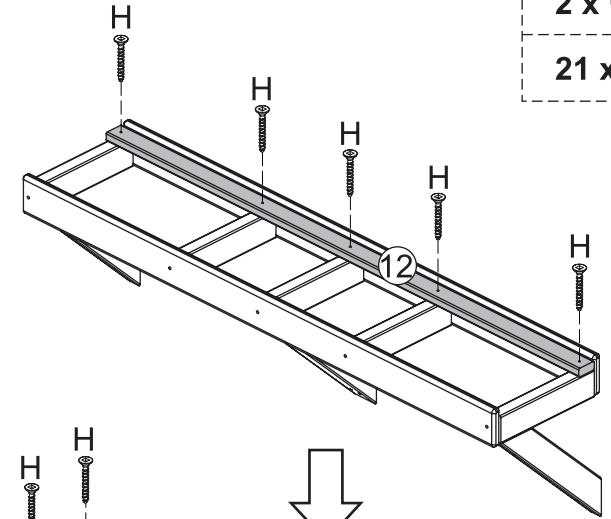
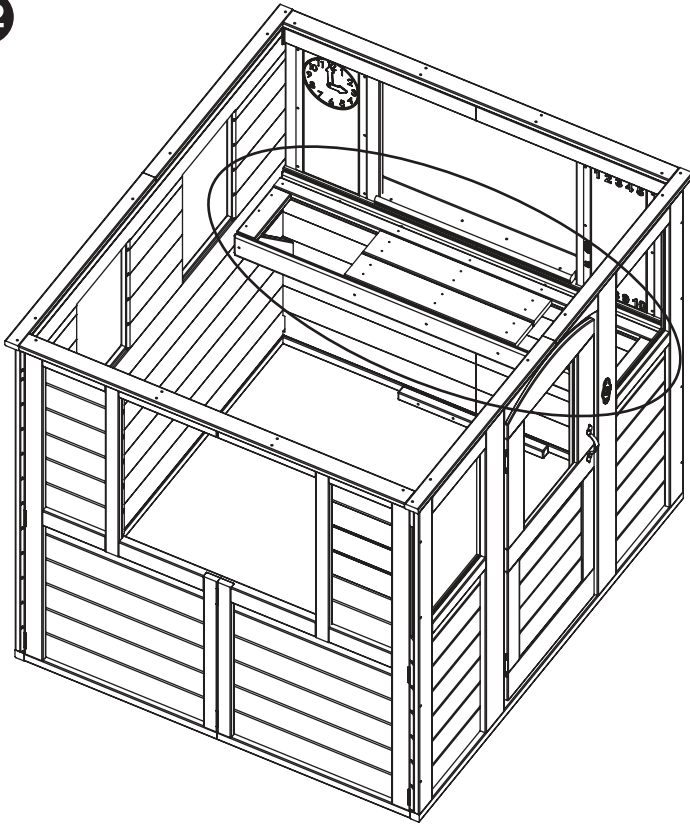

Flush
Aligné
A ras
Bündig
A filo

Tight
Serré
Ajustado
Eng anliegend
Serrato

Flush
Aligné
A ras
Bündig
A filo

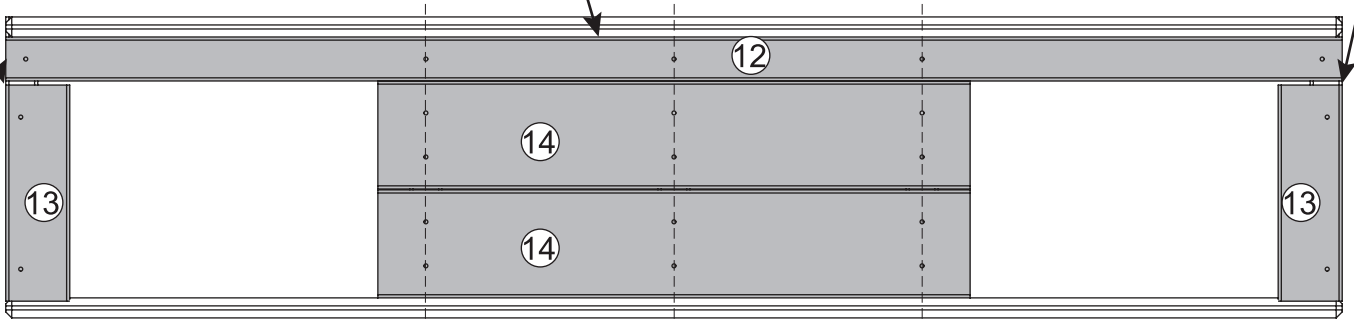

1 x 4453-DVGY

1 x 4454-BK

8 x I

10 x N

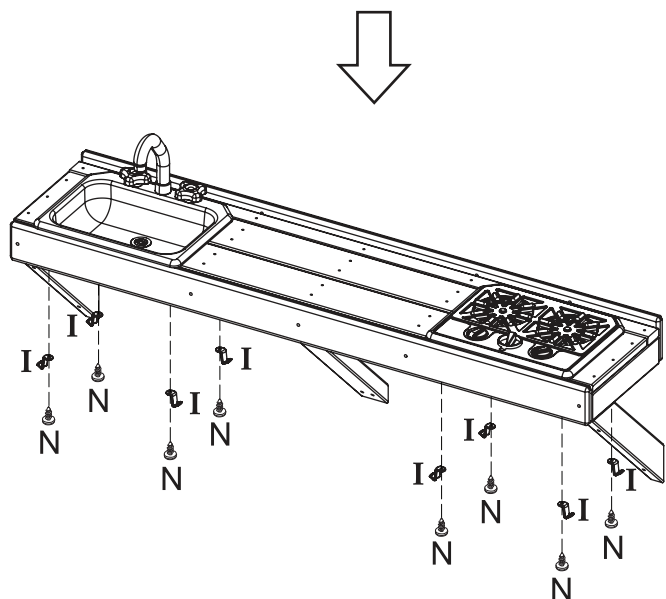
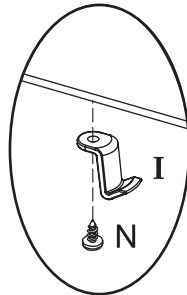
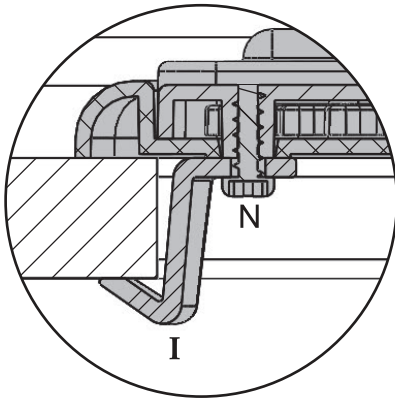
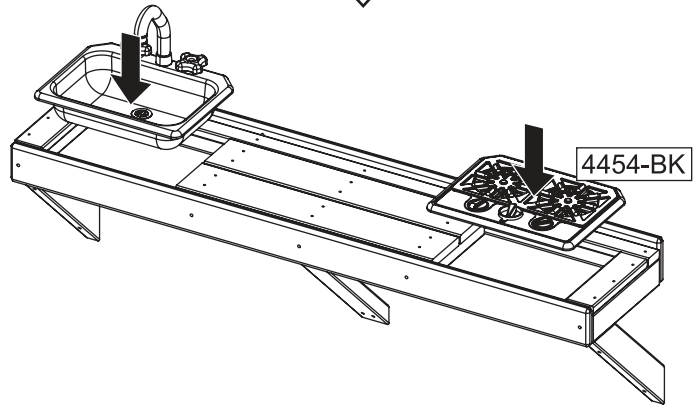
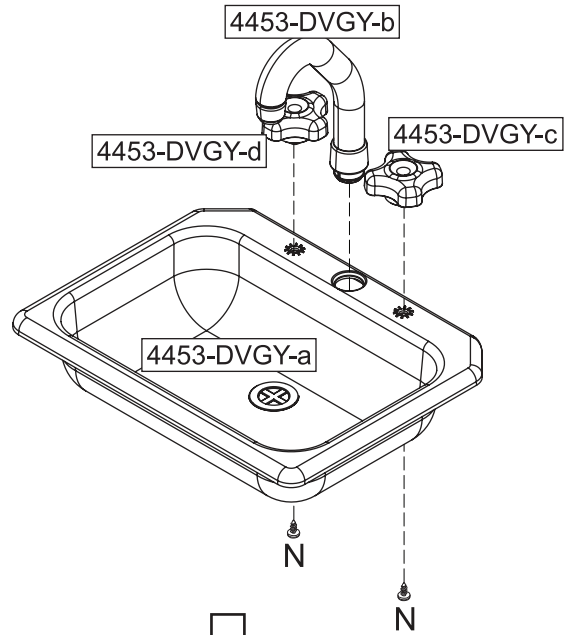
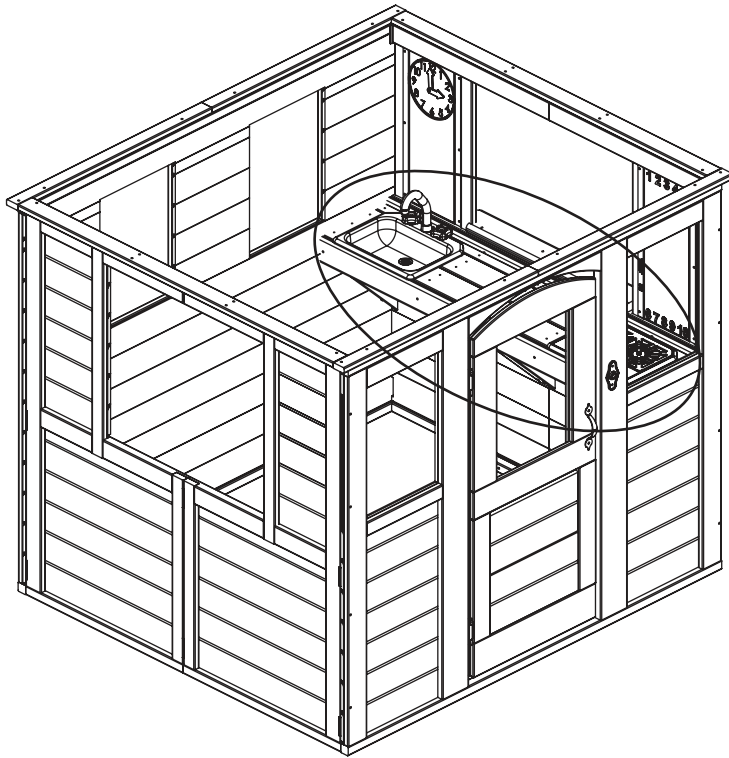

Step
Étape
Paso
Schritt
Fase

24

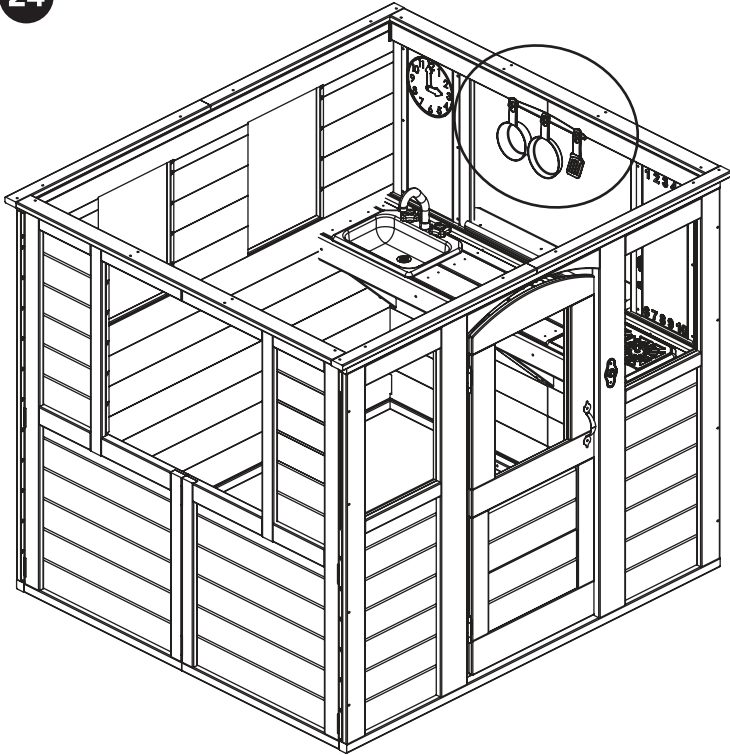

- 1 x 4463-BK
- 1 x 4452-SMGY
- 1 x 4451-SMGY
- 1 x 4450-SMGY

2 x F

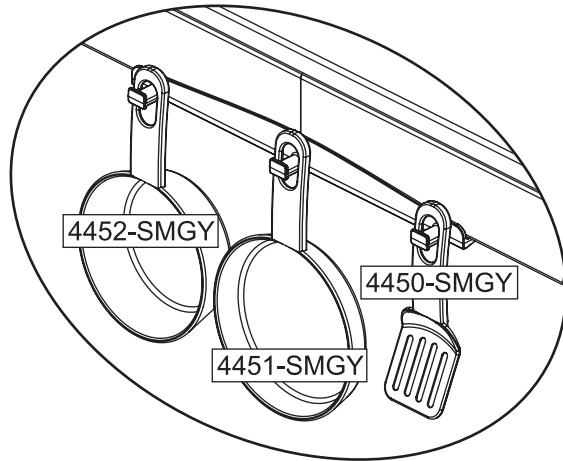
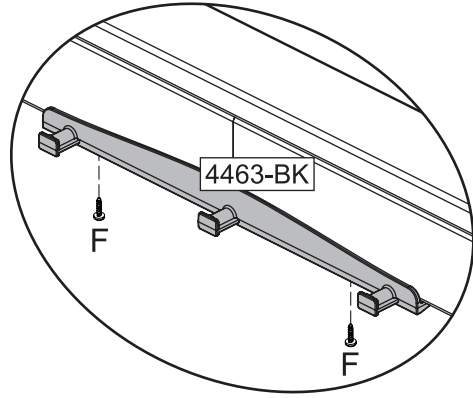

Step
Étape
Paso
Schritt
Fase

25

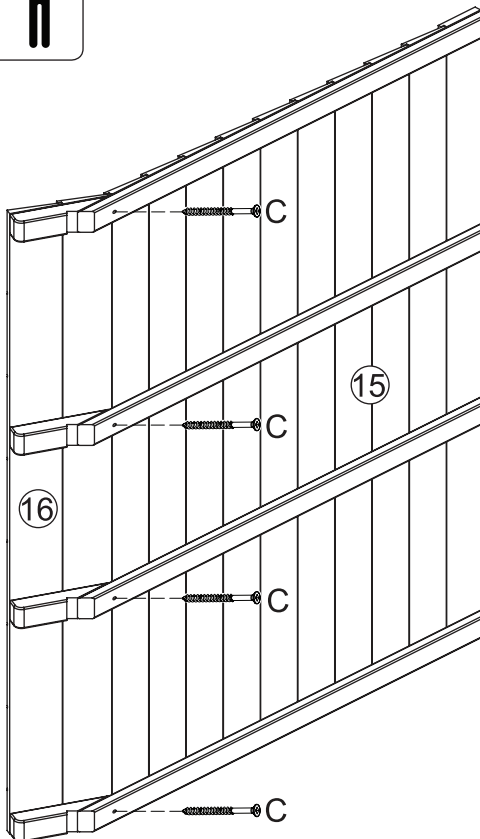

Tuck under siding overhang
Placer sous la saillie latérale
Introducir debajo del voladizo de revestimiento
Unter den Überhang des Dachbretts schieben
Infilato sotto la sporgenza laterale

1 x 15

1 x 16

4 x C

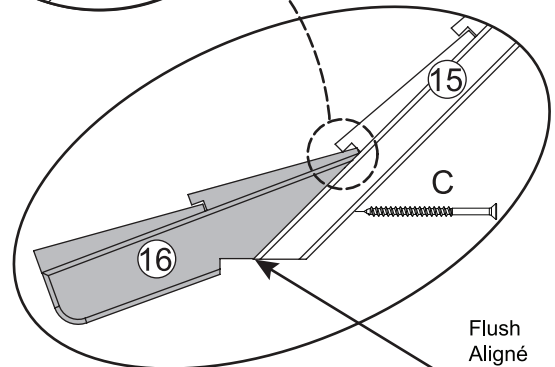
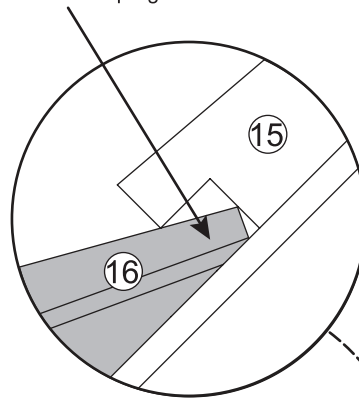

Flush
Aligné
A ras
Bündig
A filo

Step
Étape
Paso
Schritt
Fase



26

Tuck under siding overhang
Placer sous la saillie latérale
Introducir debajo del voladizo de revestimiento
Unter den Überhang des Dachbretts schieben
Infilato sotto la sporgenza laterale

1 x 16

1 x 17

4 x C

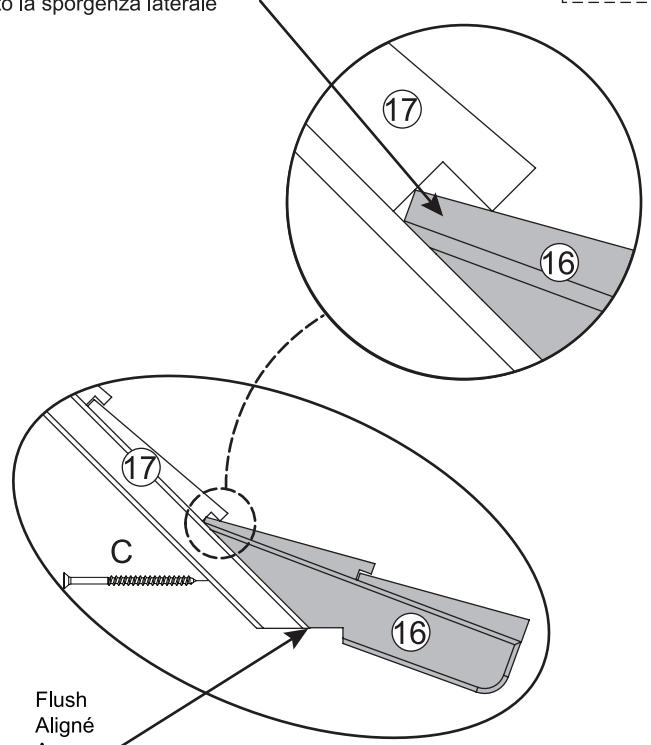
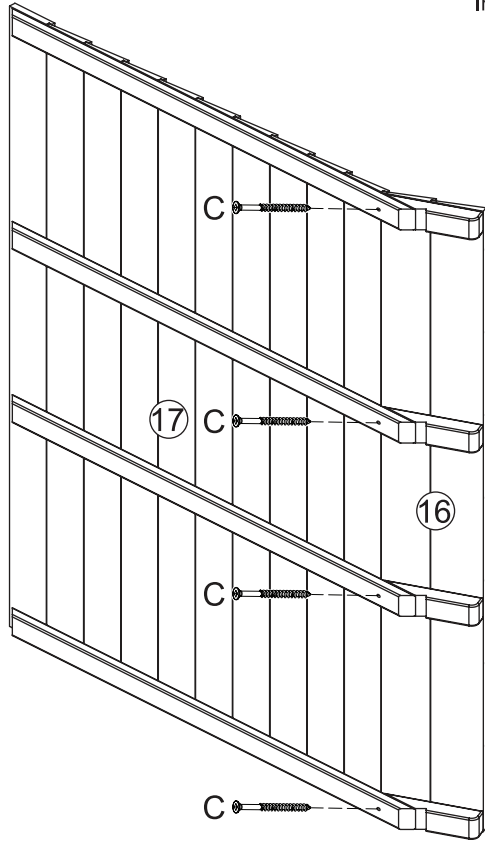

Flush
Aligné
A ras
Bündig
A filo

Step
Étape
Paso
Schritt
Fase



27

2 x J

4 x F

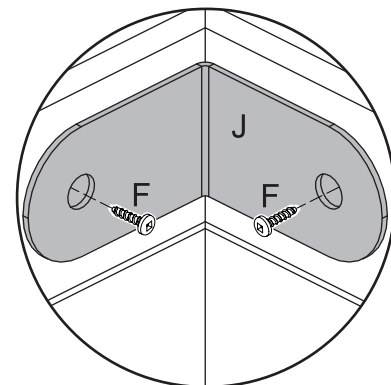
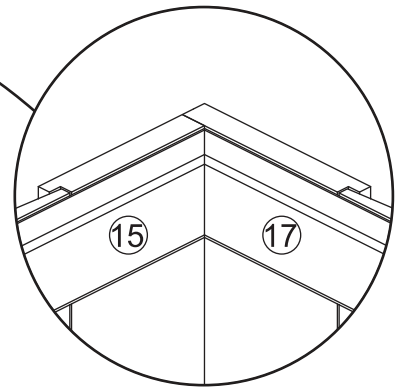
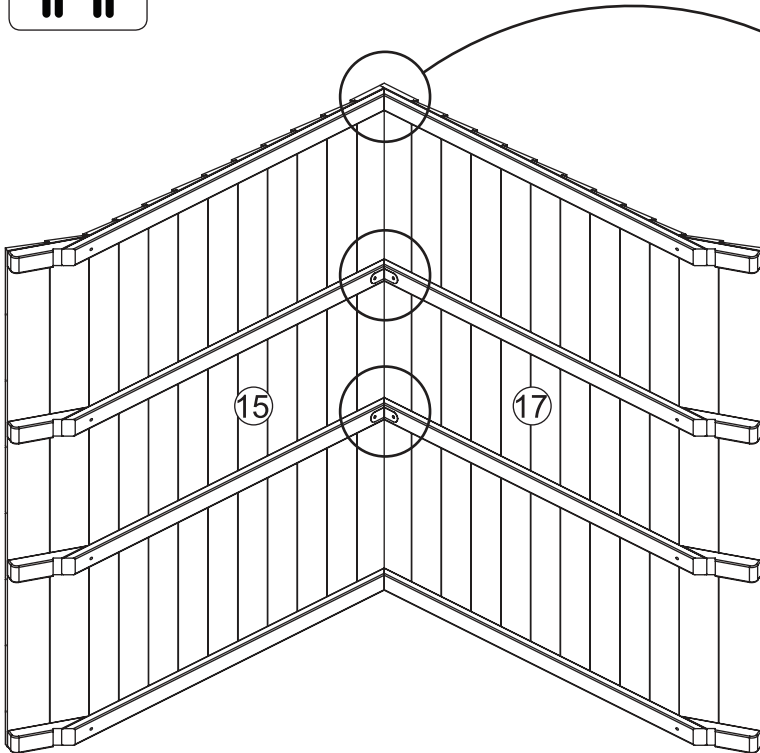

Centered
Centré
Centrado
Zentriert
Centrato

Step
Étape
Paso
Schritt
Fase

28 x 2

2 x (18a)

2 x (18b)

2 x D

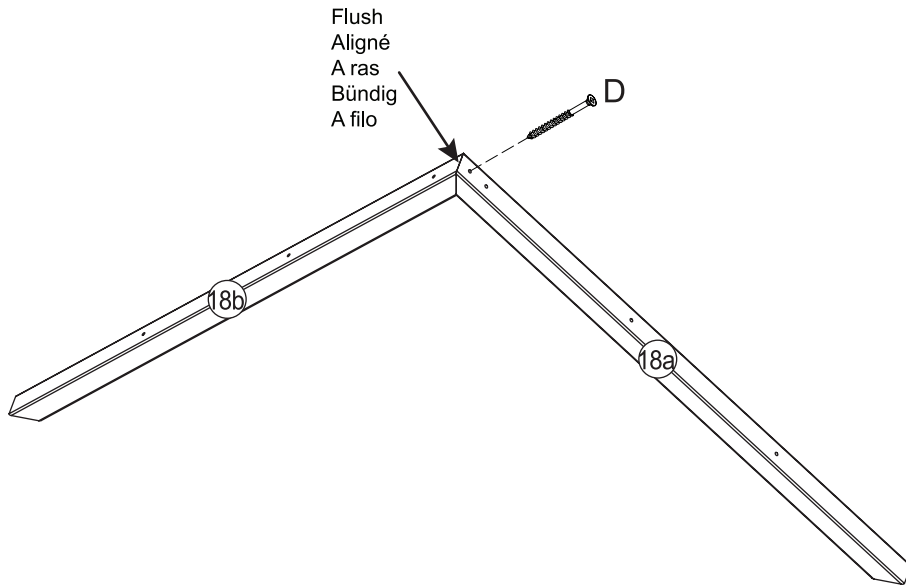

Step
Étape
Paso
Schritt
Fase

29



12 x B

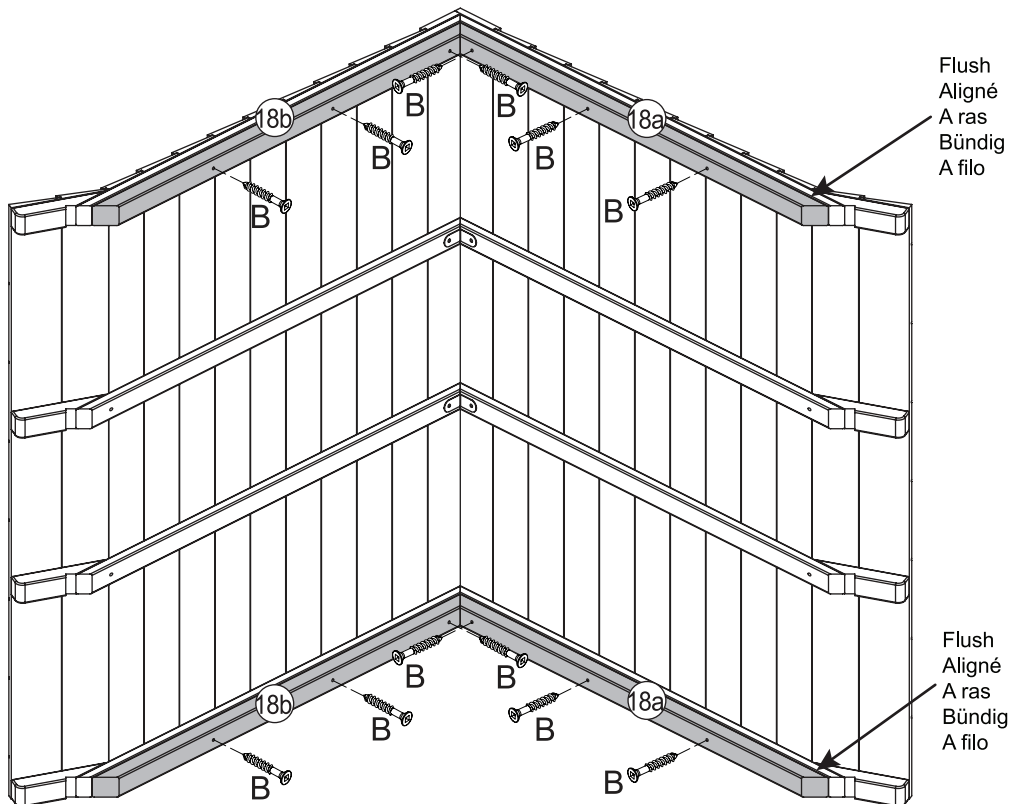

Flush
Aligné
A ras
Bündig
A filo

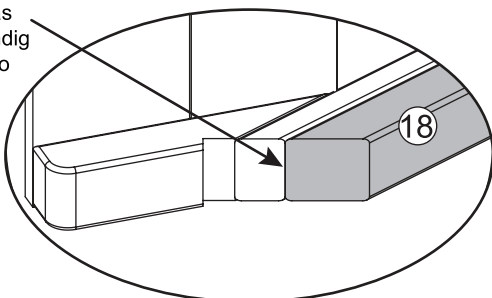

Important: Failure to make sure the bottom of the Joists and (18) Roof Sides are flush will cause assembly issues in later steps.

Important : Si vous ne vous assurez pas que le bas des Solives et les Côtés du toit (18) sont alignés, vous aurez des problèmes d'assemblage dans les étapes suivantes.

Importante: Si la parte inferior de las vigas y las piezas laterales del tejado (18) no quedan a ras, esto podría provocar problemas de montaje más adelante.

Wichtig: Achten Sie unbedingt darauf, dass die Unterseite der Balken bündig an den (18) Dachseiten anliegen, ansonsten ergeben sich Probleme für spätere Schritte.

Importante: la mancata verifica dell'allineamento a filo tra la parte inferiore dei travetti e (18) i Lati del tetto comporterà dei problemi di assemblaggio nelle fasi successive.

Step
Étape
Paso
Schritt
Fase



30

Make sure assembly is square before proceeding in this Step.

Assurez-vous que l'assemblage est bien droit avant de réaliser cette étape.

Asegúrese de que el montaje esté en perpendicular antes de pasar a este paso.

Prüfen Sie, dass die Bauteile sich im rechten Winkel zueinander befinden, bevor Sie mit diesem Schritt fortfahren.

Prima di procedere in questo passaggio, accertarsi che l'assemblato sia in squadra.

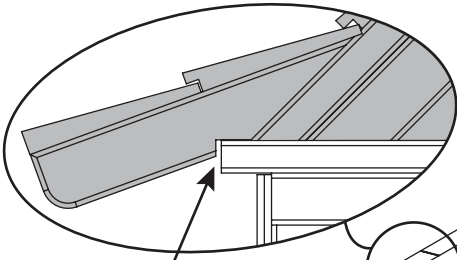

Tight
Serré
Ajustado
Eng anliegend
Serrato

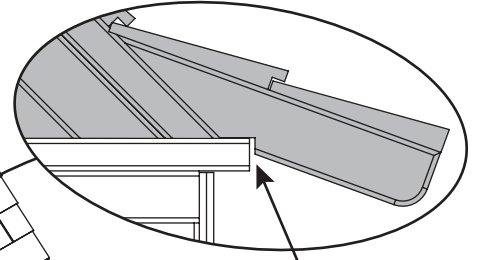

Tight
Serré
Ajustado
Eng anliegend
Serrato

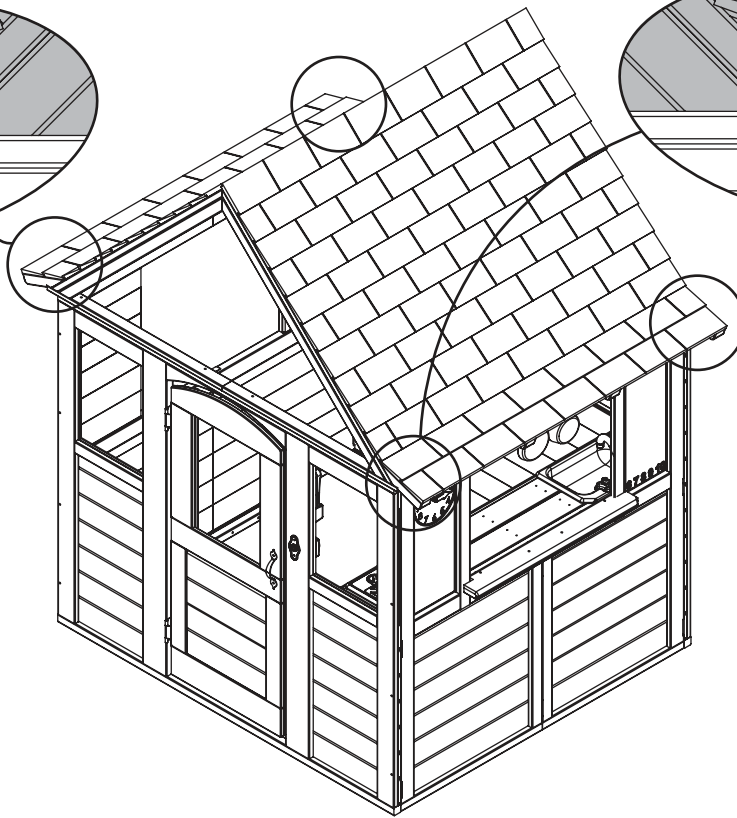

Step
Étape
Paso
Schritt
Fase

31

4 x C

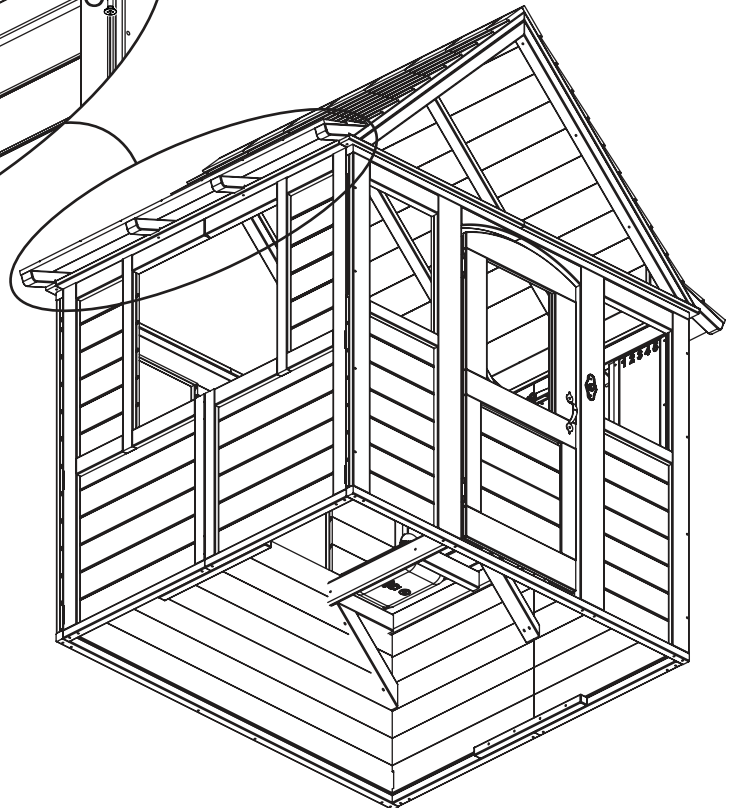
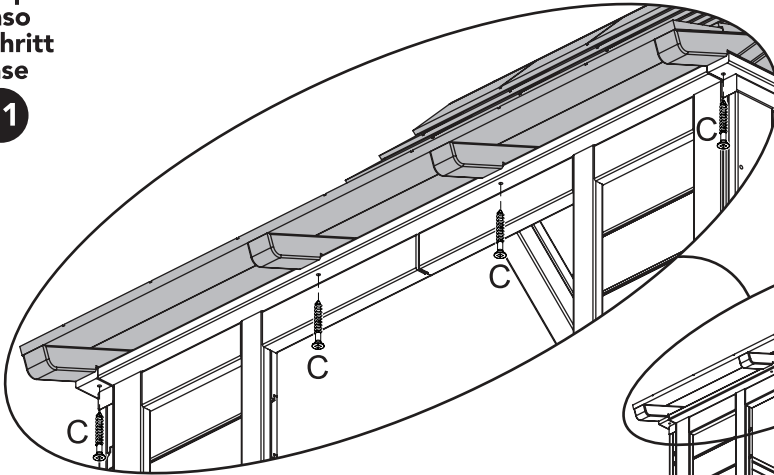

Step
Étape
Paso
Schritt
Fase

32

4 x C

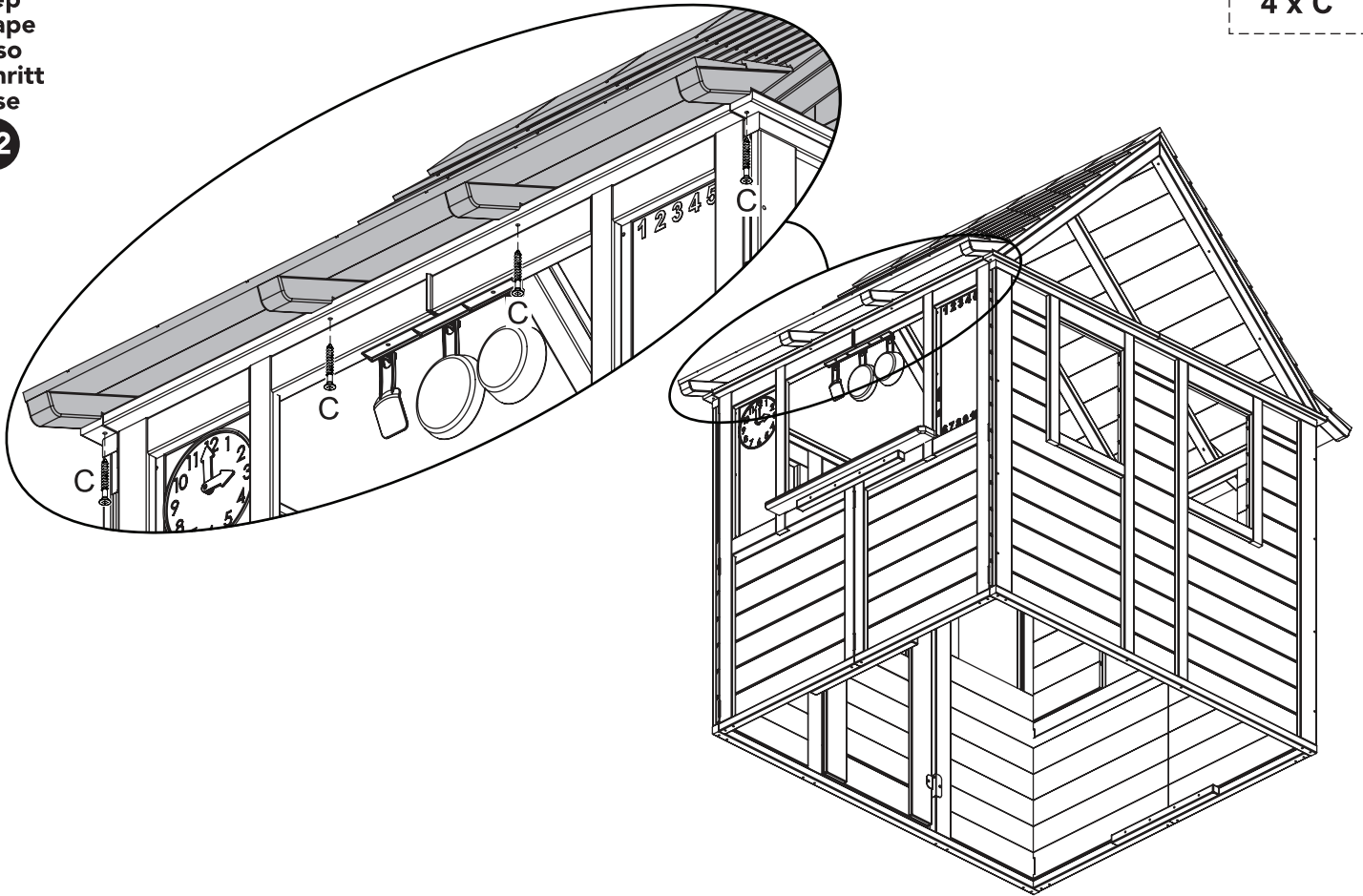

Step
Étape
Paso
Schritt
Fase

33

Important! Inside View
Important ! Vue intérieure
¡Importante! Vista interior
Wichtig! Innenansicht
Importante! Vista dall'interno

1 x 19
2 x 20
2 x 21
2 x 22
1 x 23
1 x 24

36 x A

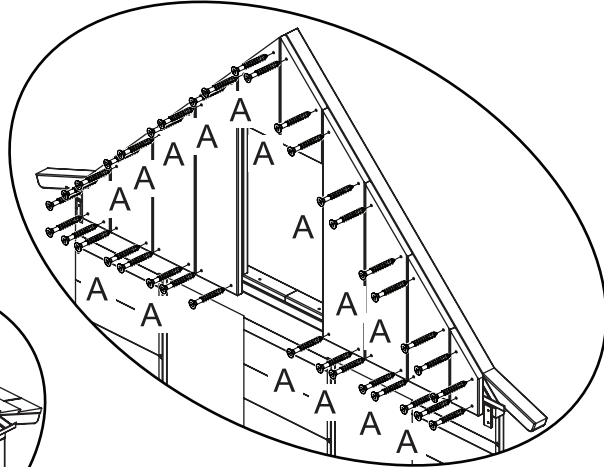
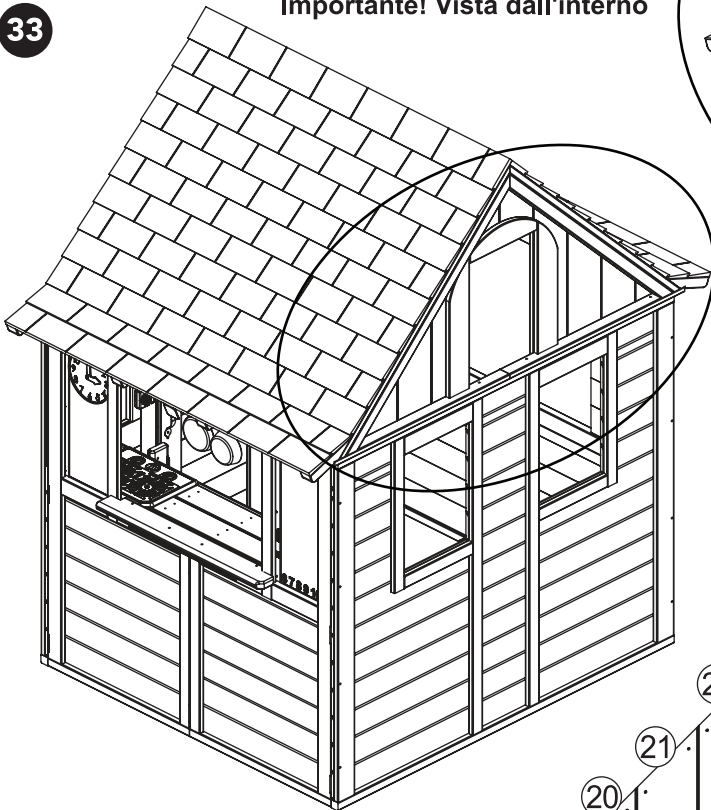

Start Here and assemble down
Commencez ici et assemblez vers le bas
Empezar aquí y continuar hacia abajo
Hier beginnen und nach unten hin weitermachen
Iniziare da qui e assemblare verso il basso

Important! Inside View
Important ! Vue intérieure
¡Importante! Vista interior
Wichtig! Innenansicht
Importante! Vista dall'interno

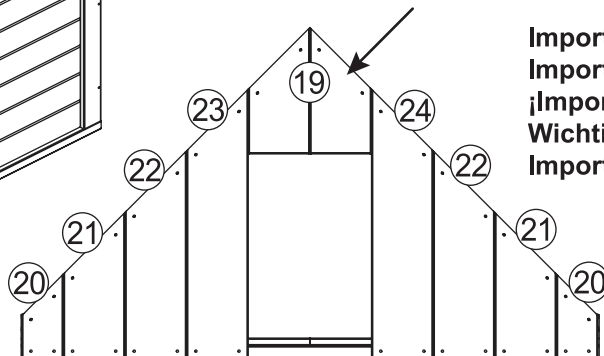

Step
Étape
Paso
Schritt
Fase

34

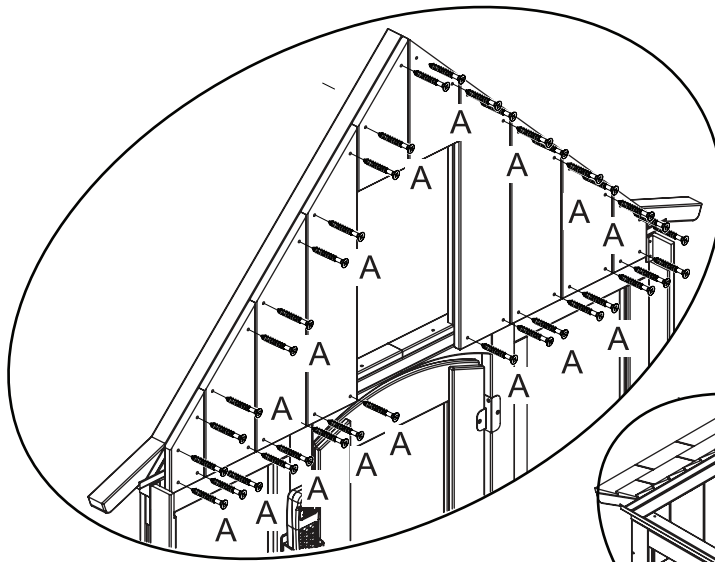

Important! Inside View
Important ! Vue intérieure
¡Importante! Vista interior
Wichtig! Innenansicht
Importante! Vista dall'interno

- 1 x 19
- 2 x 20
- 2 x 21
- 2 x 22
- 1 x 23
- 1 x 24

36 x A

Start Here and assemble down
Commencez ici et assemblez vers le bas
Empezar aquí y continuar hacia abajo
Hier beginnen und nach unten hin weitermachen
Iniziare da qui e assemblare verso il basso

Important! Inside View
Important ! Vue intérieure
¡Importante! Vista interior
Wichtig! Innenansicht
Importante! Vista dall'interno

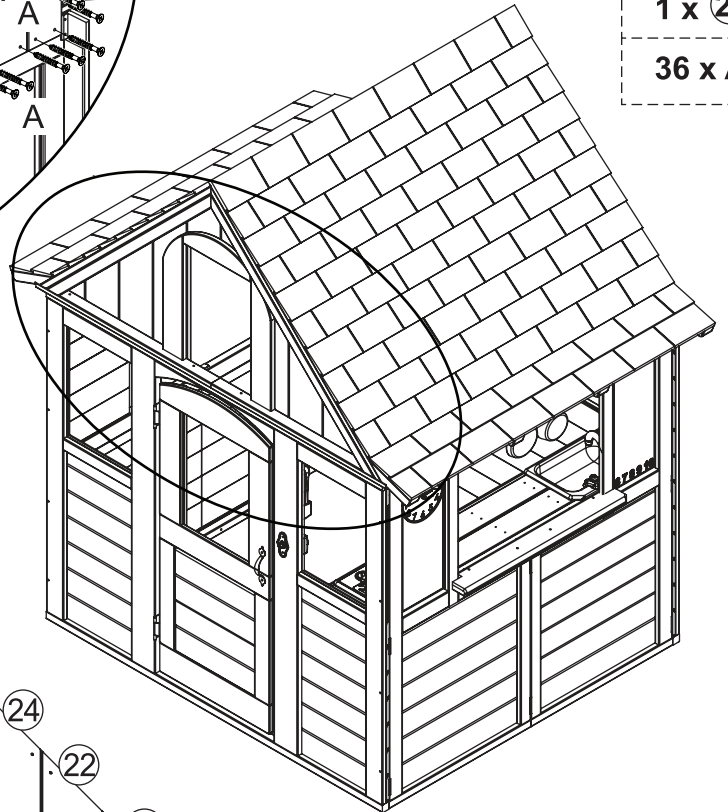
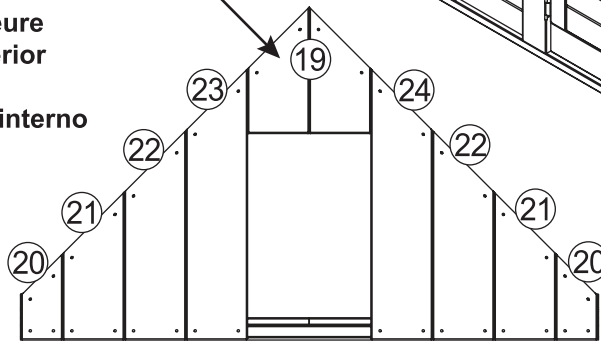

Step
Étape
Paso
Schritt
Fase

35

Centered
Centré
Centrado
Zentriert
Centrato

Flush
Aligné
A ras
Bündig
A filo

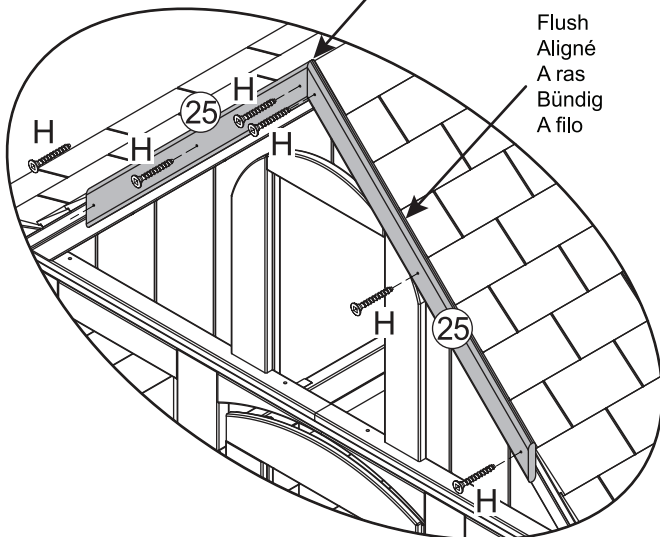

- 2 x 25

6 x H

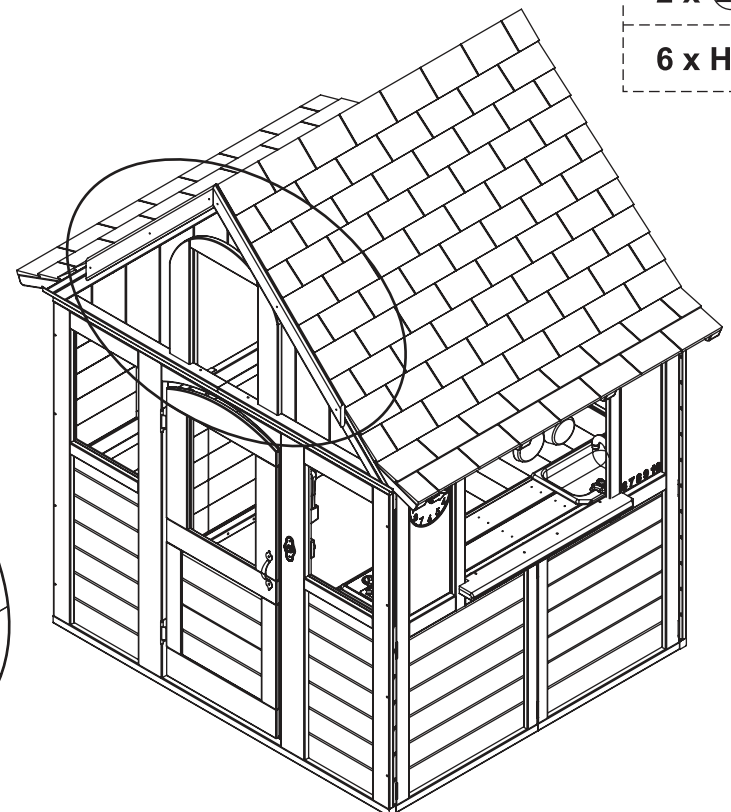

Step
Étape
Paso
Schritt
Fase

36

2 x 26

6 x H

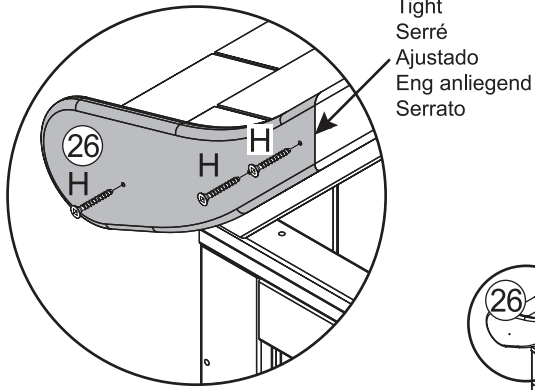

Tight
Serré
Ajustado
Eng anliegend
Serrato

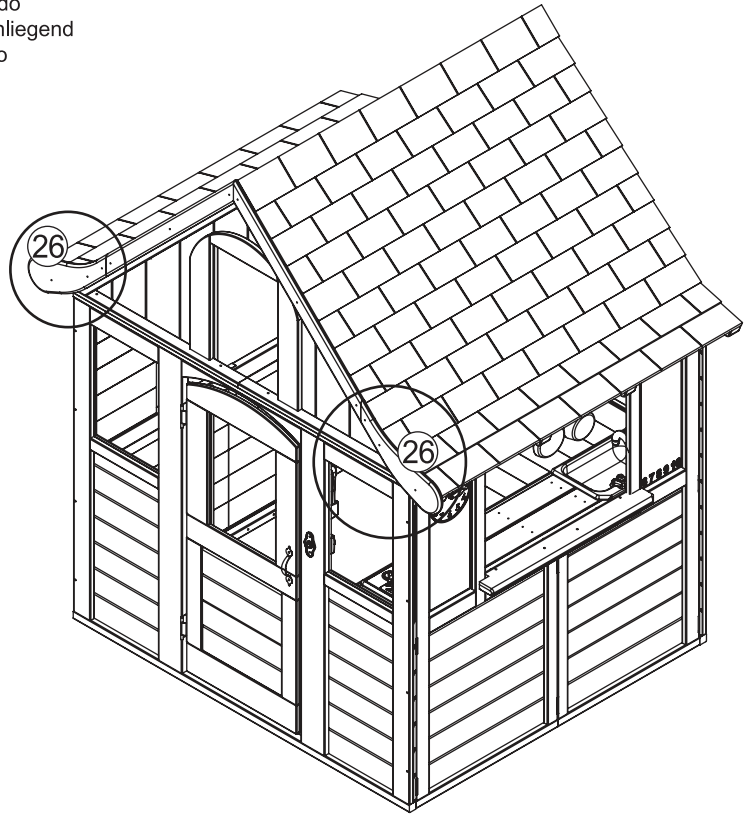
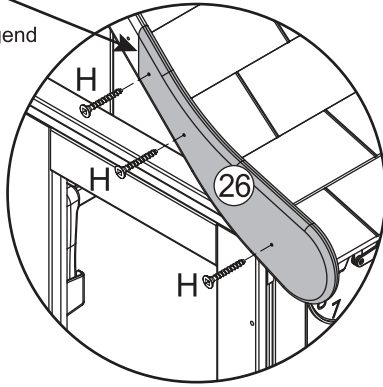

Step
Étape
Paso
Schritt
Fase

37

2 x 25

6 x H

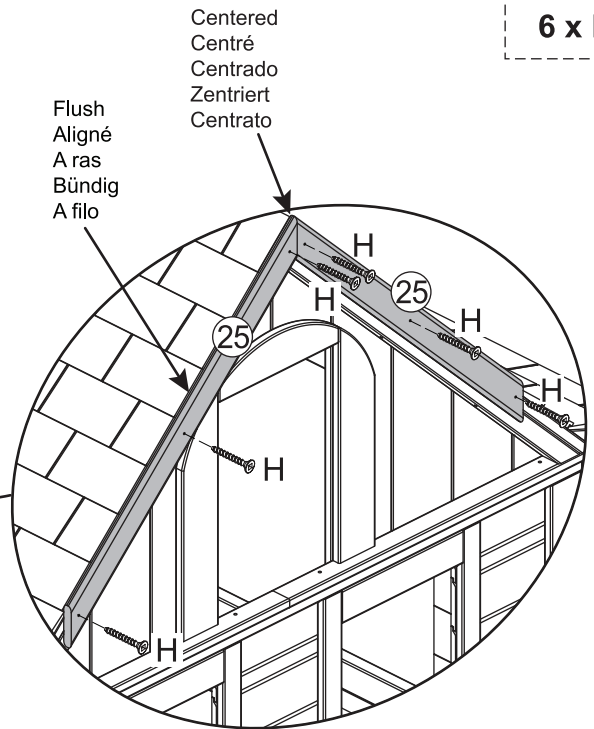
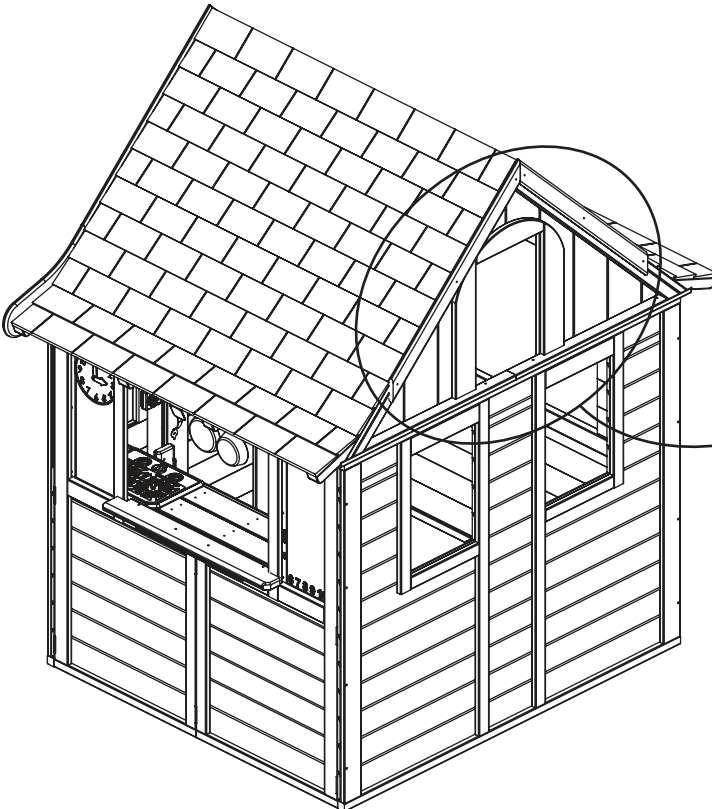

Step
Étape
Paso
Schritt
Fase

38

2 x 26

6 x H

Tight
Serré
Ajustado
Eng anliegend
Serrato

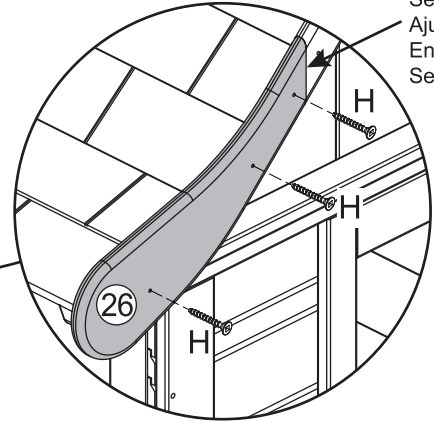
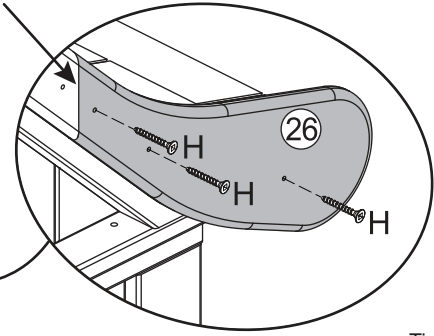
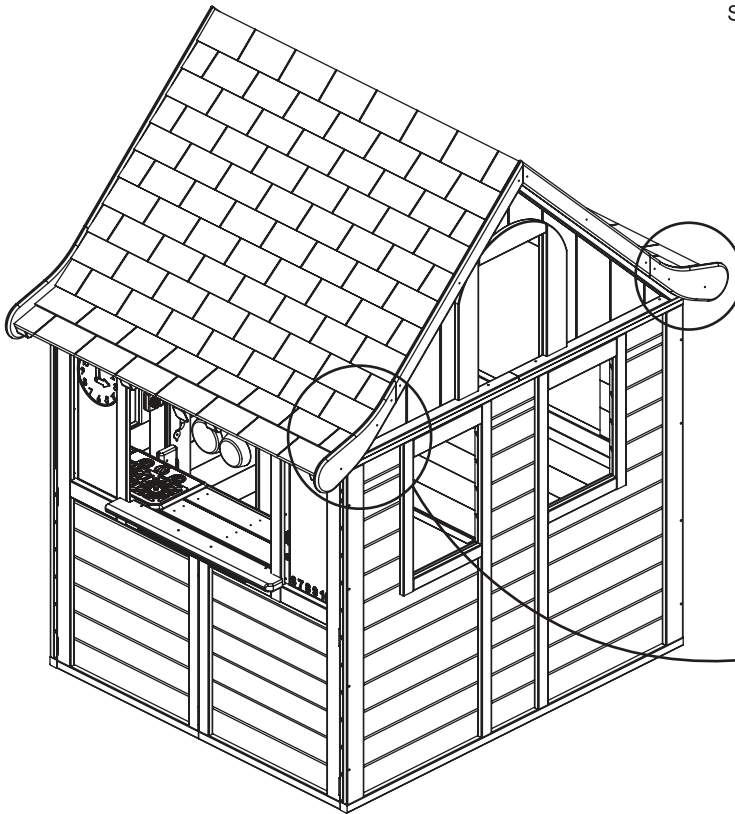

Tight
Serré
Ajustado
Eng anliegend
Serrato

Step
Étape
Paso
Schritt
Fase

39

8 x B

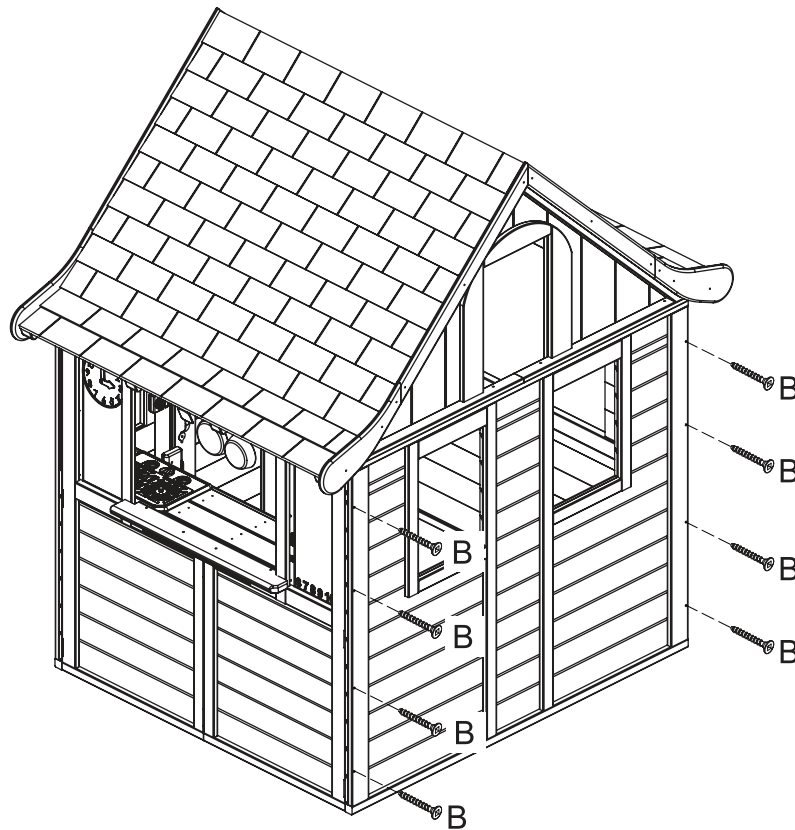

Step
Étape
Paso
Schritt
Fase

40

8 x B

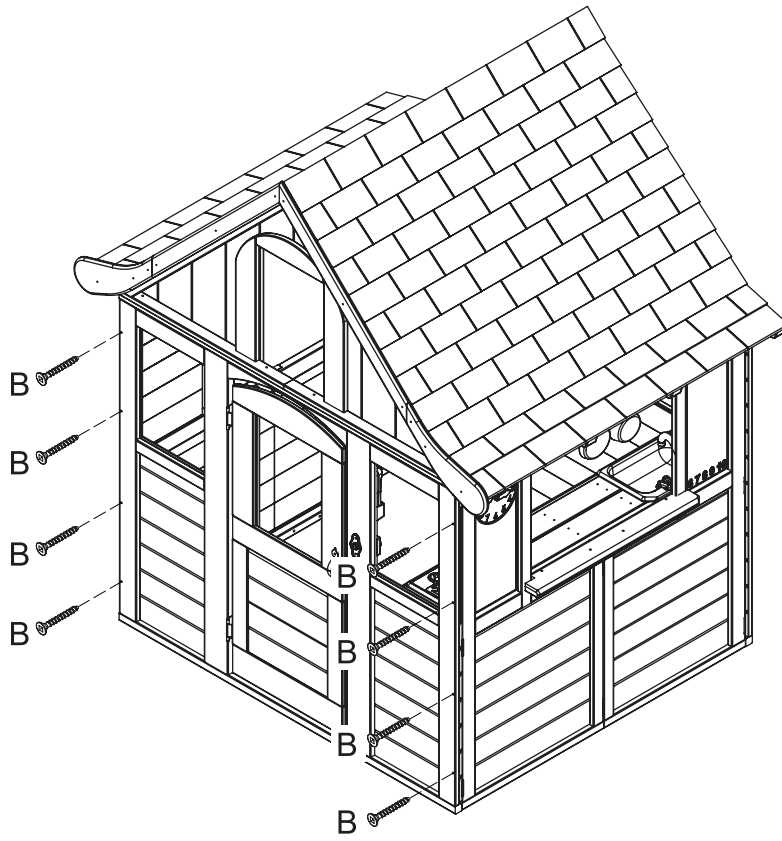

Step
Étape
Paso
Schritt
Fase

41

1 x 4457-WT-a

4 x F

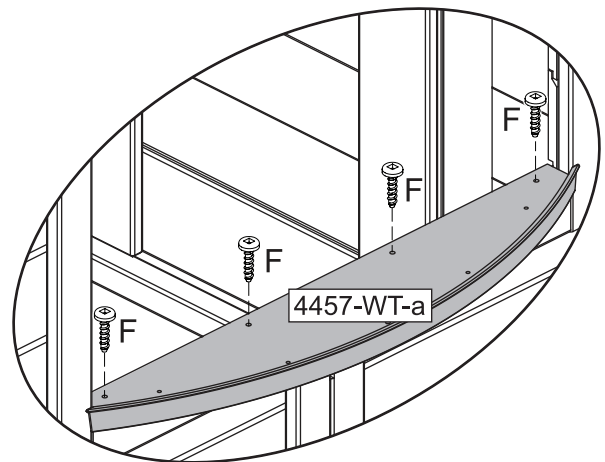
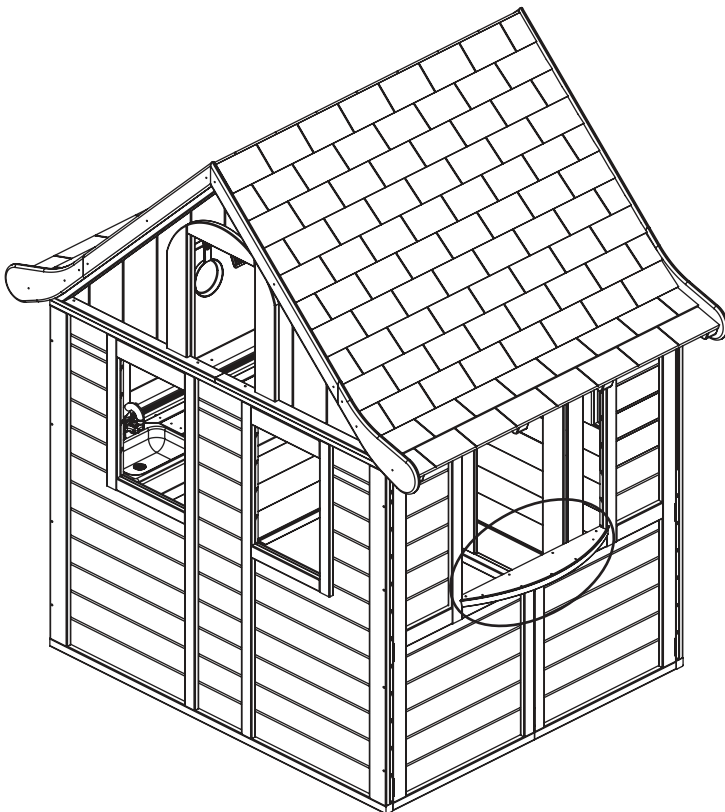

Inside View
Vue intérieure
Vista interior
Innenansicht
Vista dall'interno

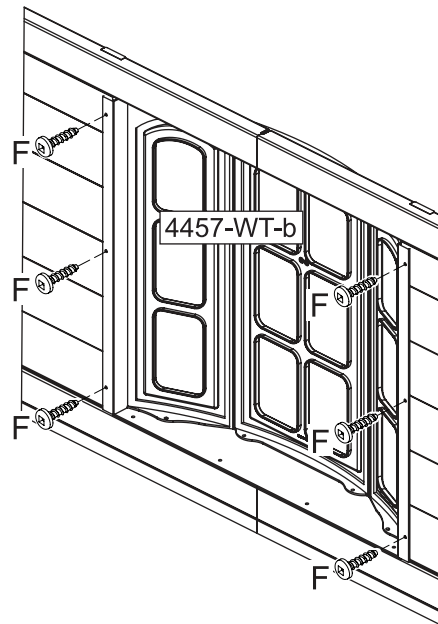
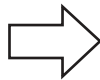
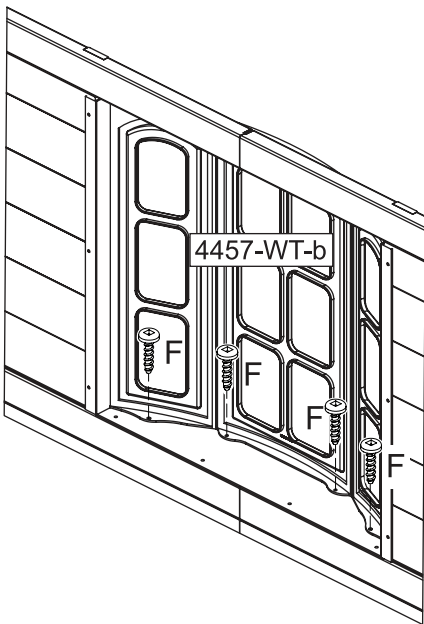
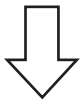
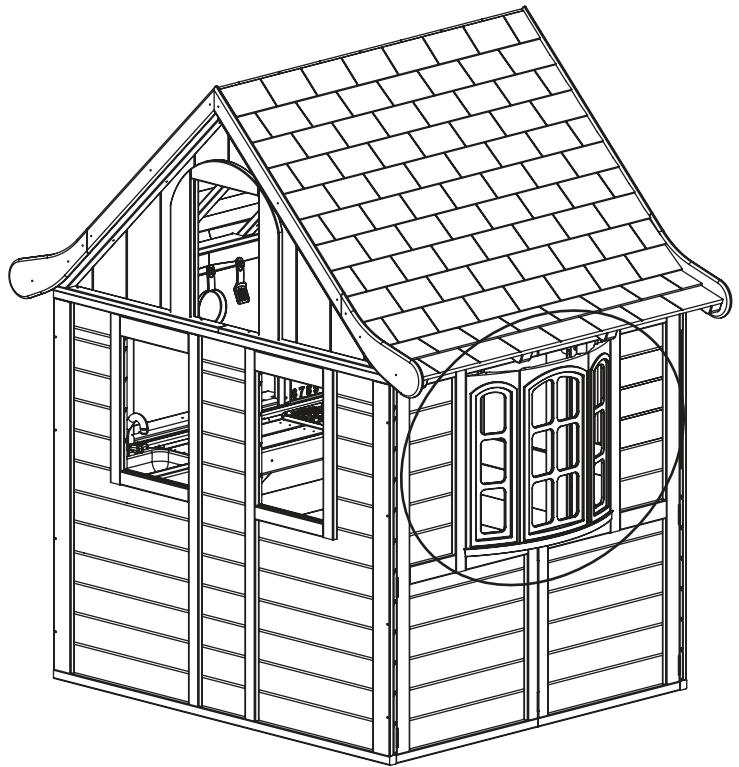
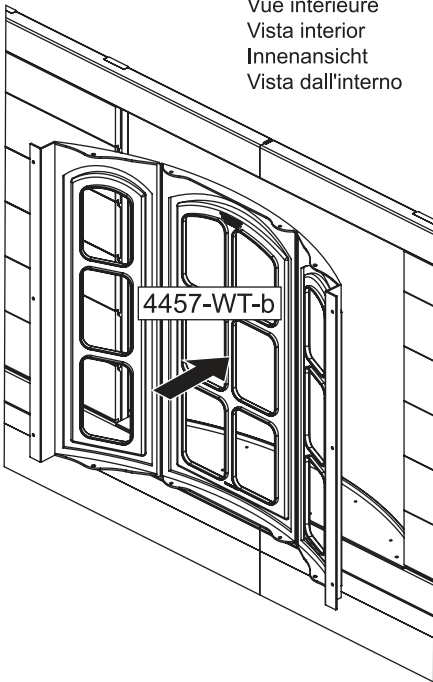

Step
Étape
Paso
Schritt
Fase

43

1 x 4457-WT-c

8 x F

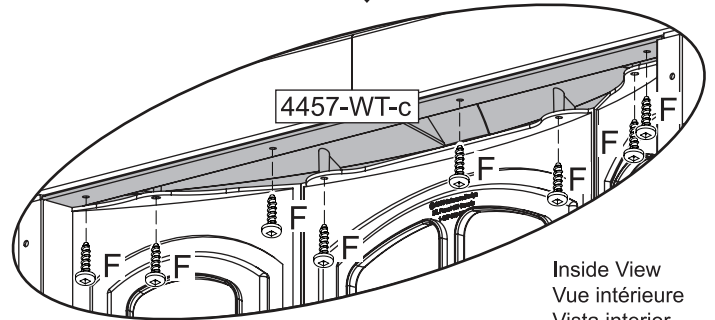
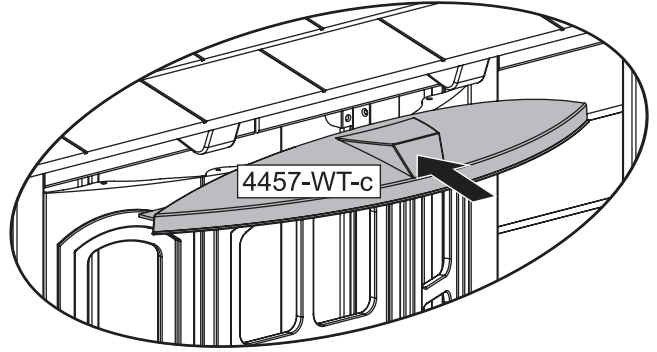
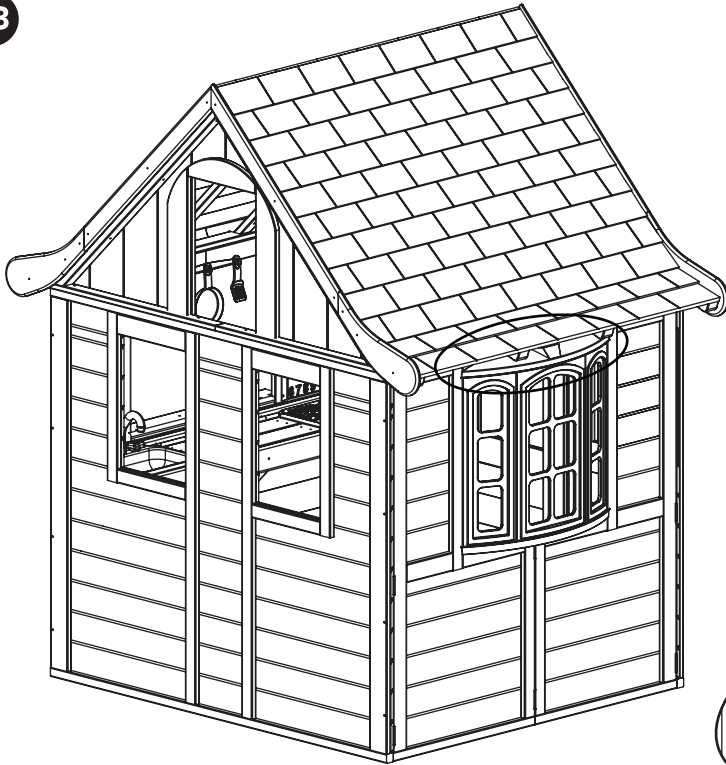

Inside View
Vue intérieure
Vista interior
Innenansicht
Vista dall'interno

Step
Étape
Paso
Schritt
Fase

44

3 x 5943-WT

12 x F

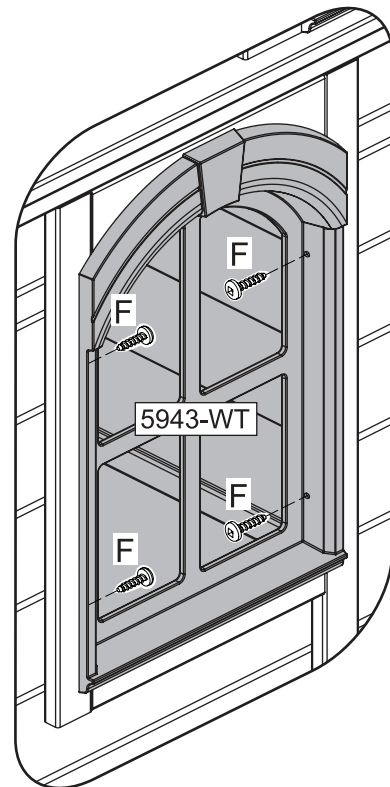
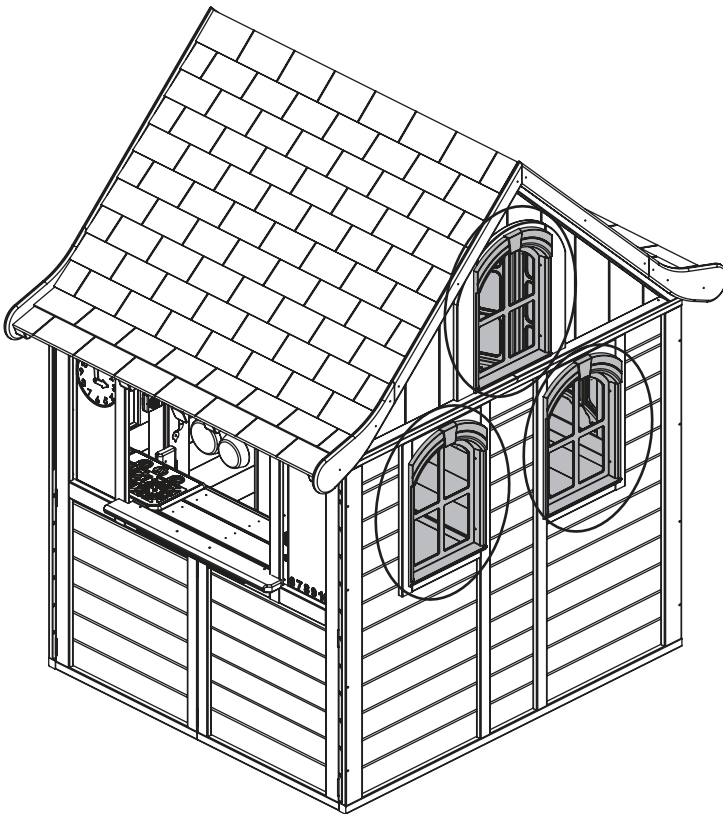

Step
Étape
Paso
Schritt
Fase

45

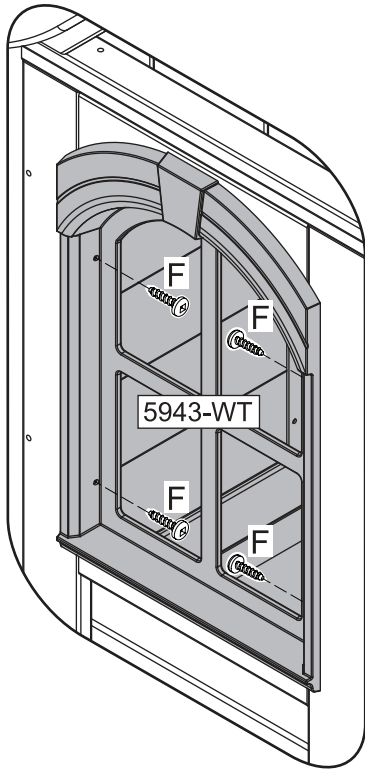

4 x 5943-WT

16 x F

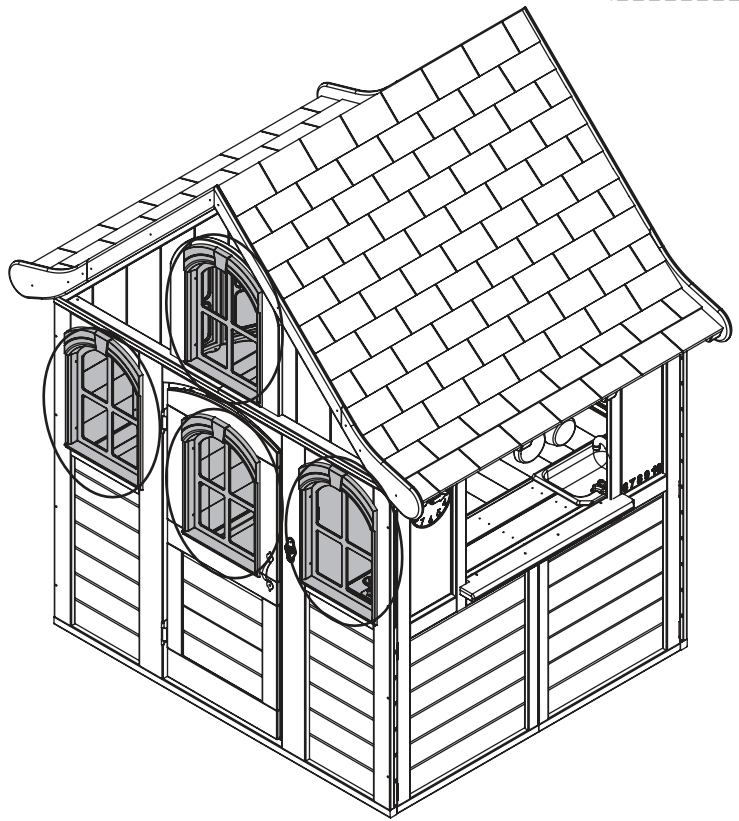

Step
Étape
Paso
Schritt
Fase

46

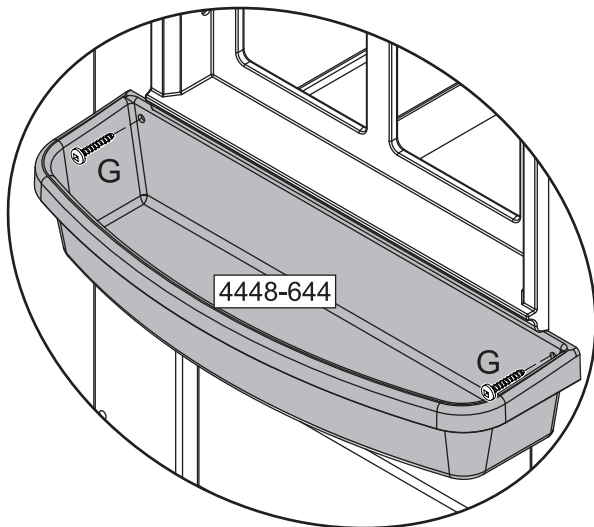

2 x 4448-644

4 x G

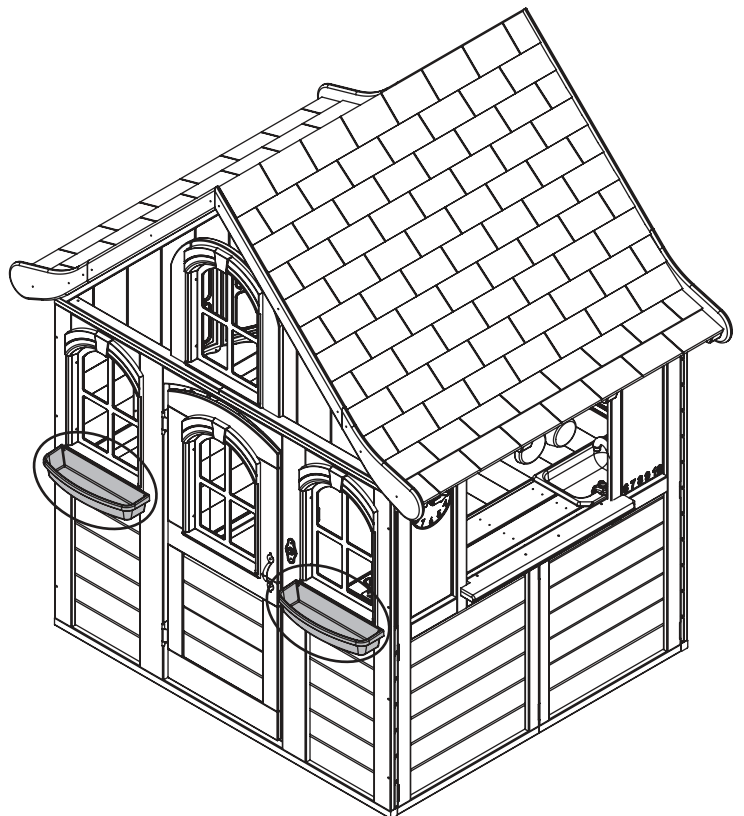

Step
Étape
Paso
Schritt
Fase

47

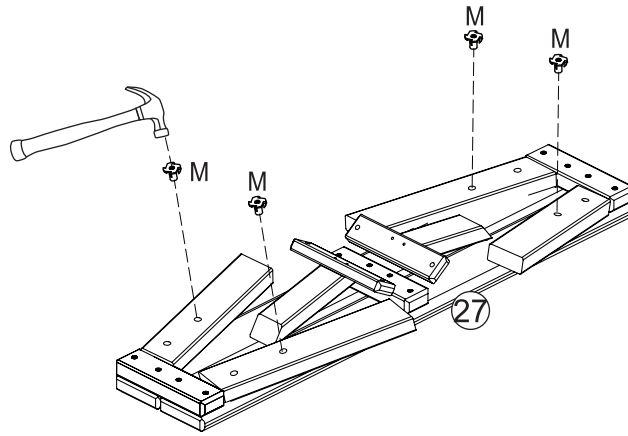

1 x 27

4 x M

Step
Étape
Paso
Schritt
Fase

48

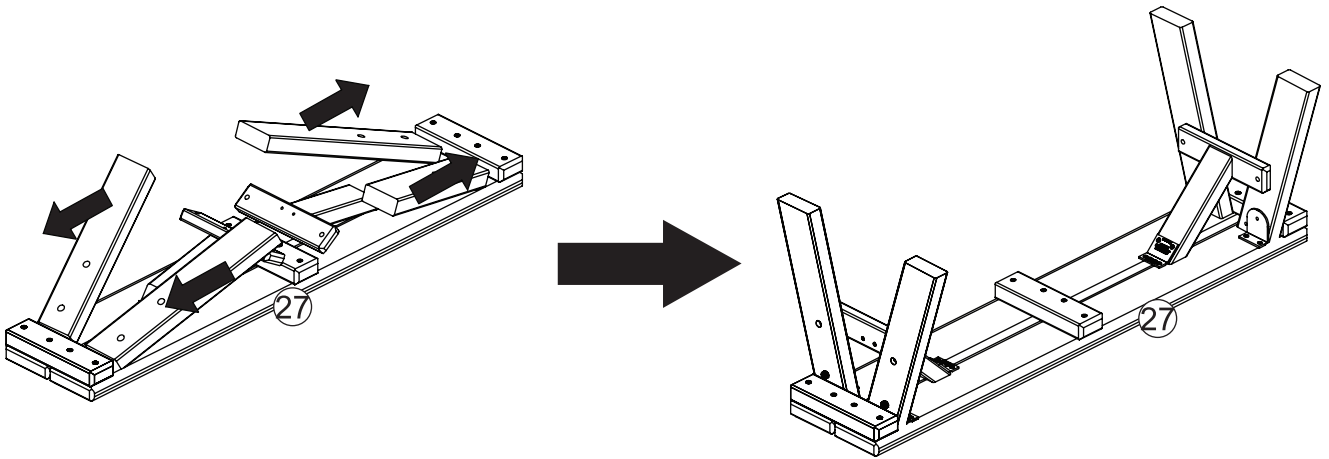

Step
Étape
Paso
Schritt
Fase

49

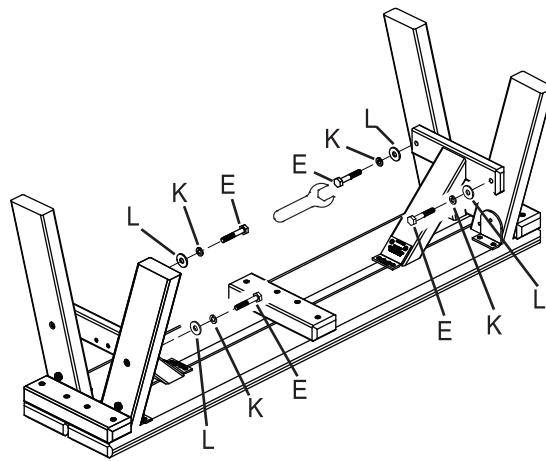

4 x E

4 x K

4 x L

Step
Étape
Paso
Schritt
Fase

50

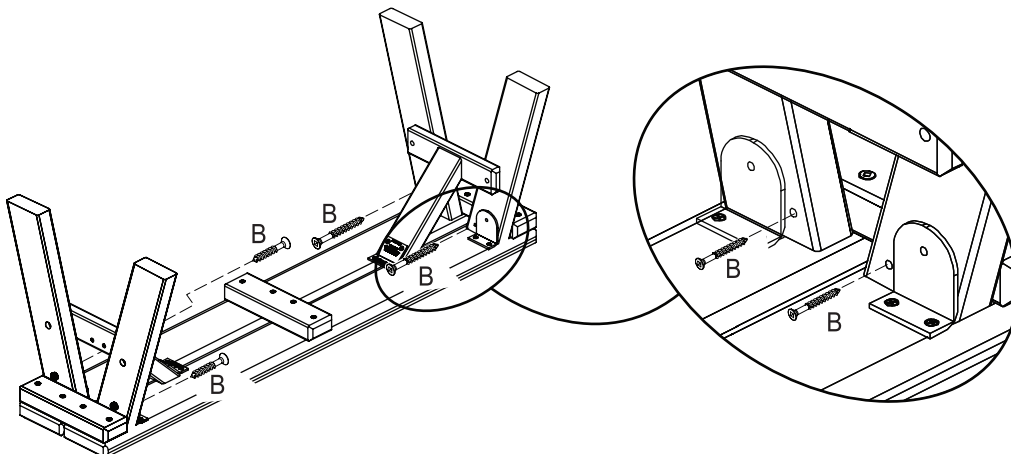

4 x B