

NOTES: UNLESS OTHERWISE SPECIFIED

1. FOR GENERAL SERIES SPECIFICATIONS, SEE SD74-0000.
2. MATERIAL SPECIFICATIONS: BRASS (B05) PER UNS53800
3. FINISH SPECIFICATIONS:
 BODY: .000030 MIN GOLD PER ASTM B488 OVER
 .000050 MIN NICKEL PER AMS-QQ-N-290
4. ELECTRICAL SPECIFICATIONS:
 CURRENT RATING: 30 AMPS
5. FOR USE WITH 10 GA. OR EQUIVALENT WIRE.
6. REFER TO CAP10-01 FOR CABLE ASSEMBLY PROCEDURE.

REV	DESCRIPTION	BY DATE	APPD
C	REVISED PER ER7306	04/11/08 CWB	CWB

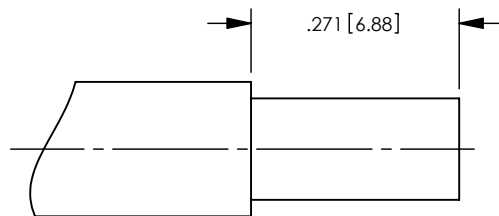
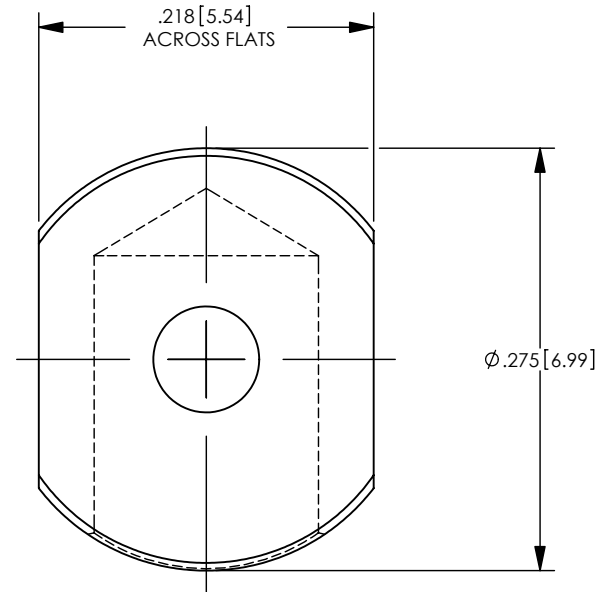
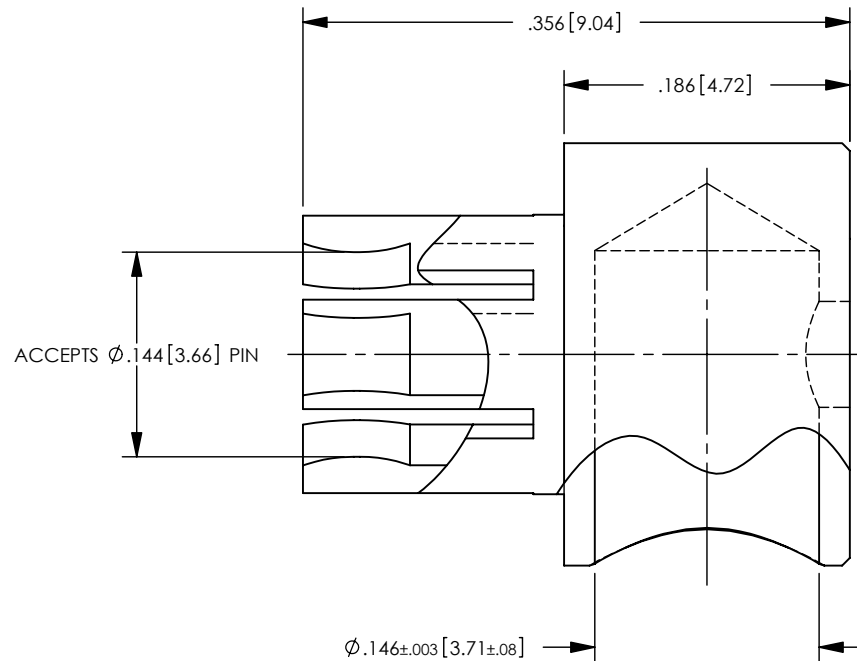

RECOMMENDED CABLE TRIM DIMENSIONS
SCALE: 4:1

CATALOG P/N: 01362

PER ASME Y14.5M-1994 UNLESS OTHERWISE SPECIFIED: DIMENSIONS ARE IN INCHES [MM] TOLERANCES: DECIMAL: .XX [X.X] ± .01 [0.3] .XXX [X.XX] ± .005 [0.13] .XXXX [X.XXX] ± .XXXX ANGLES: ± 2° SCALE: 8:1				 Winchester Electronics Corporation 62 Barnes Industrial Road North Wallingford, Connecticut 06492	
CUSTOMER DRAWING					
DRAWN	DATE	APPROVED	DATE	POWERSNAP, RIGHT ANGLE SOLDER MOUNT 10 AWG, 30 AMP	
JEM	10/15/03	CWB	10/15/03		
APPROVED	DATE	APPROVED	DATE	A	SD01362
JED	10/15/03	SD	10/15/03		