

SIDES	BOTTOM
9 1/2" KNOCKOUTS	3 1/2" KNOCKOUTS
	2 1/2"-3/4" MOON KNOCKOUTS
2 PCS 8-32X1/2 Screws Installed	
Material: Steel-0.0625"-G60 Galvanized	

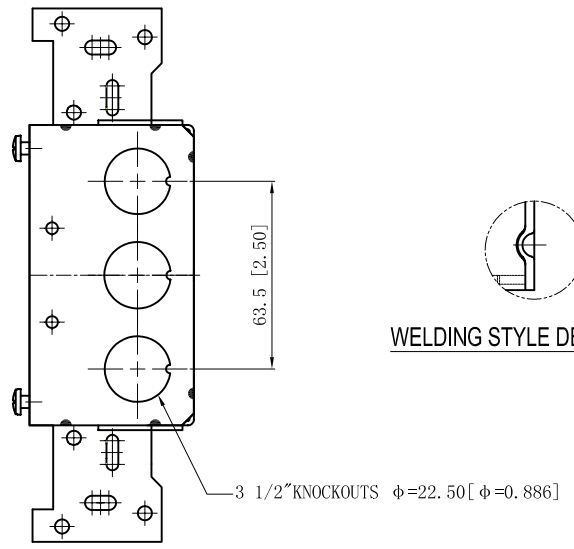
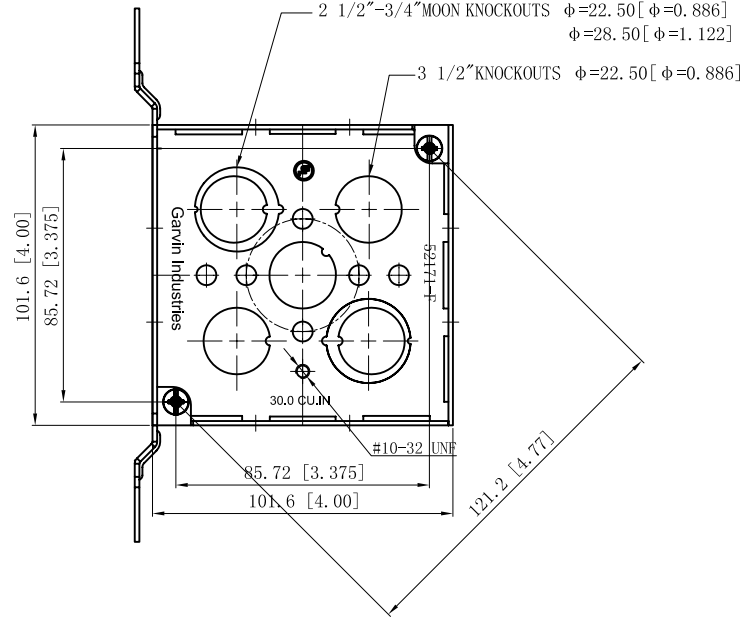
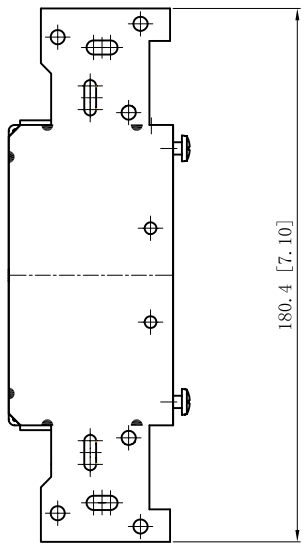
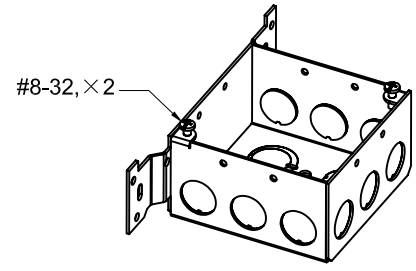
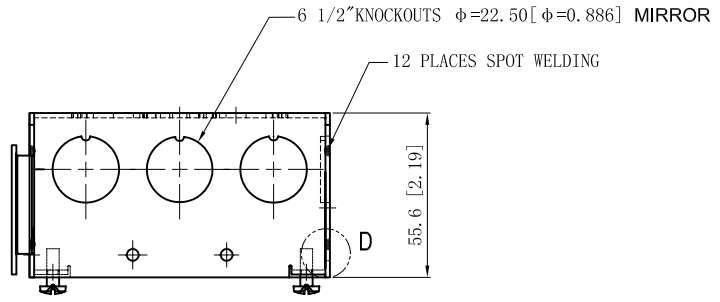

DESCRIPTION
TRADE REFERENCE TERMS

This data sheet is for reference only .GARVIN INDUSTRIES reserves the right to make changes to the design without prior notice.

STANDARD PACKING	<h1 style="text-align: center;">GARVIN INDUSTRIES</h1>		
25 PCS	SIZE	DWG NO.	REV
	A4	52171-F	B
DATA SHEET			