

IMPORTANT!

Addendum to PG100 manual

Used on page 18

Parts #07 - 52" Main Beam are missing 4 holes. Mark and drill four 1/8" diameter holes at locations shown. Holes should be through part.

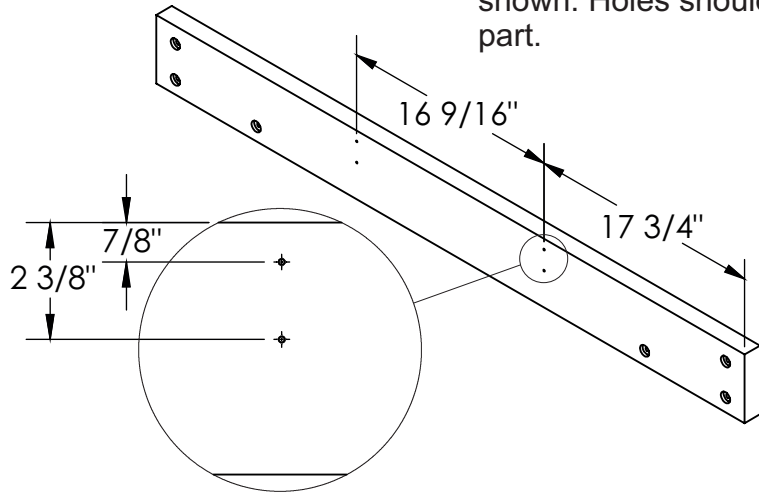

IMPORTANT!

Addendum to PG100 manual

Used on page 18

Parts #07 - 52" Main Beam is missing 4 holes. Mark and drill four 1/8" diameter holes at locations shown. Holes should be through part.

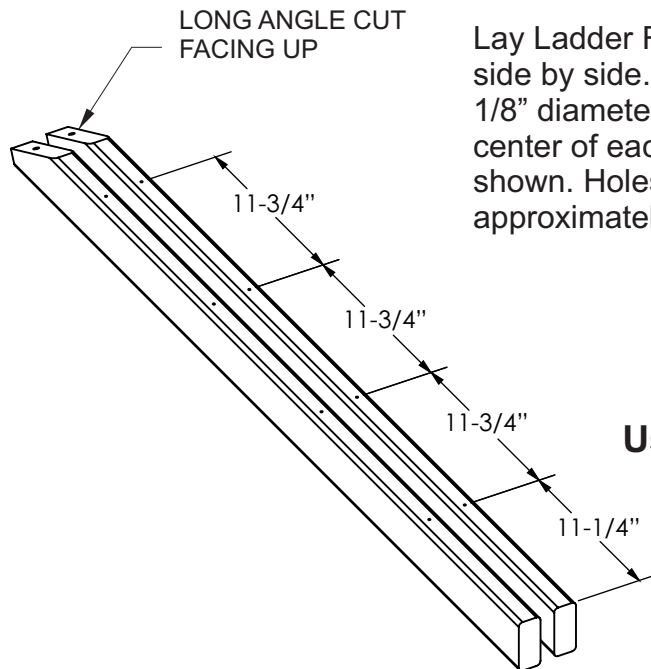
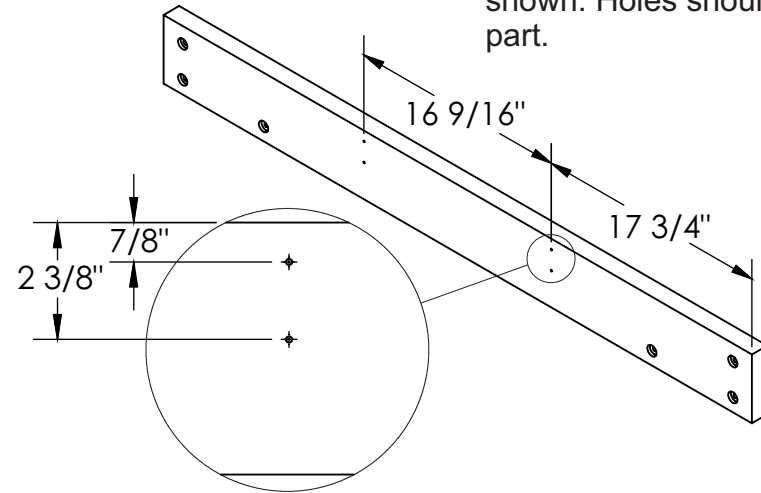

Lay Ladder Rails (PG-24-0031) side by side. Mark and drill four 1/8" diameter holes along the center of each rail at locations shown. Holes should be approximately 1/4" deep.

Used on page 19

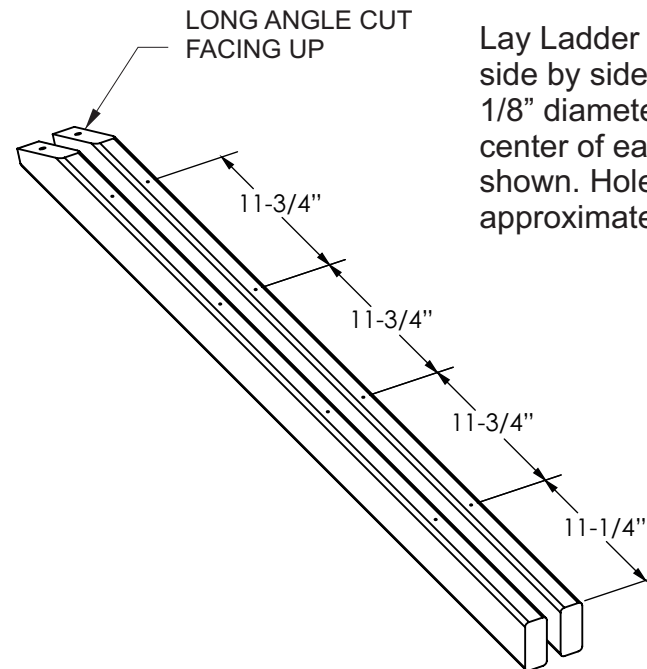

Lay Ladder Rails (PG-24-0031) side by side. Mark and drill four 1/8" diameter holes along the center of each rail at locations shown. Holes should be approximately 1/4" deep.

Used on page 19