

INSTRUCTION MANUAL

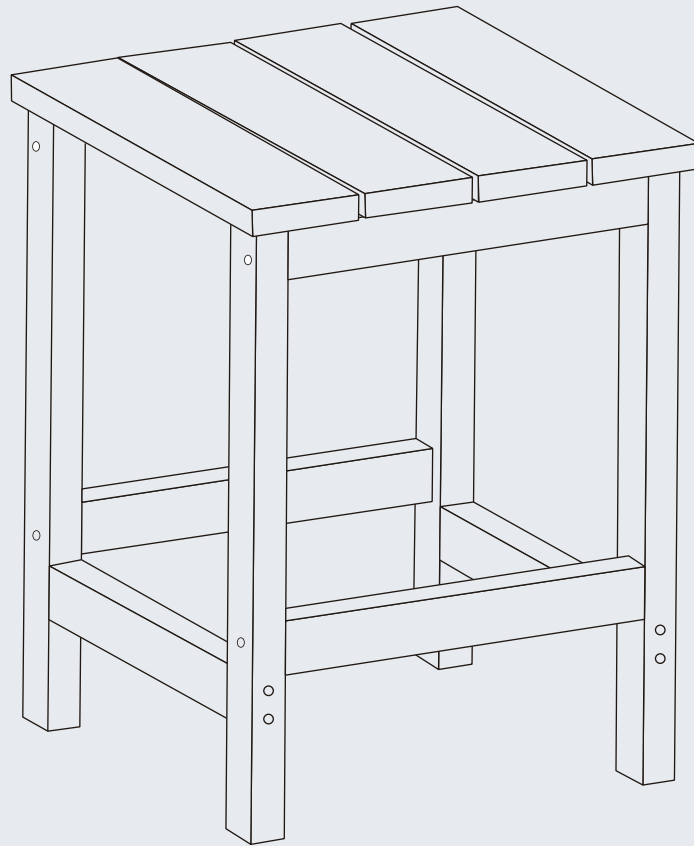

Outdoor Poly Adirondack Side Table

V2.0

! NOTICE

Do not overtighten screws or bolts. (Insert all screws before tighten screws.)

- Please do not exceed the weight limitations of this item.
- Do not stand on or use any part of this item as a step ladder.
- Firmly secure all bolts, screws and nuts before use.
- Reconfirm that all bolts, screws, and nuts are secure every 90 days.
- Do not use or store this item in the proximity of open flame or flammable/combustible chemicals.
- Avoid using strong power tool for avoiding to crack the PE board when assembling.

TOOLS REQUIRED



TABLE
180 LBS
CAPACITY



1 PERSON
ASSEMBLY



UP TO 20 MIN.
ASSEMBLY

HARDWARE

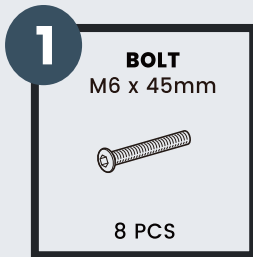

PARTS

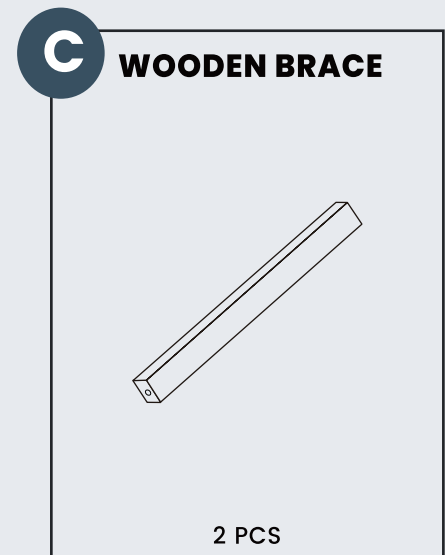
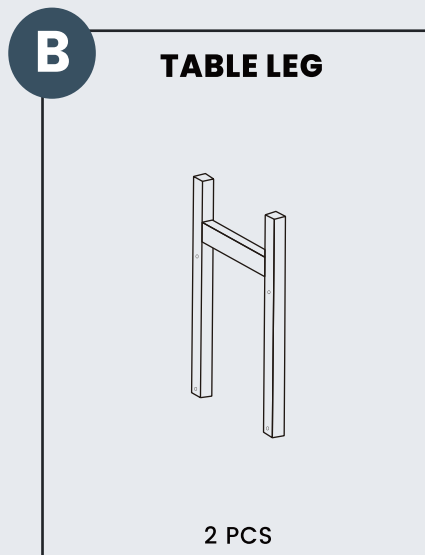
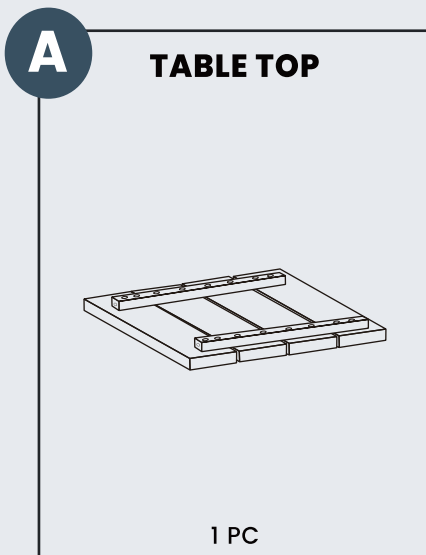

PRODUCT ASSEMBLY

1

Attach **Part B Table Leg** to **Part A Table Top** with 2 pcs of **Hardware #1 Bolt** using an **Allen Wrench**.

Do not tighten bolts too much at this stage.

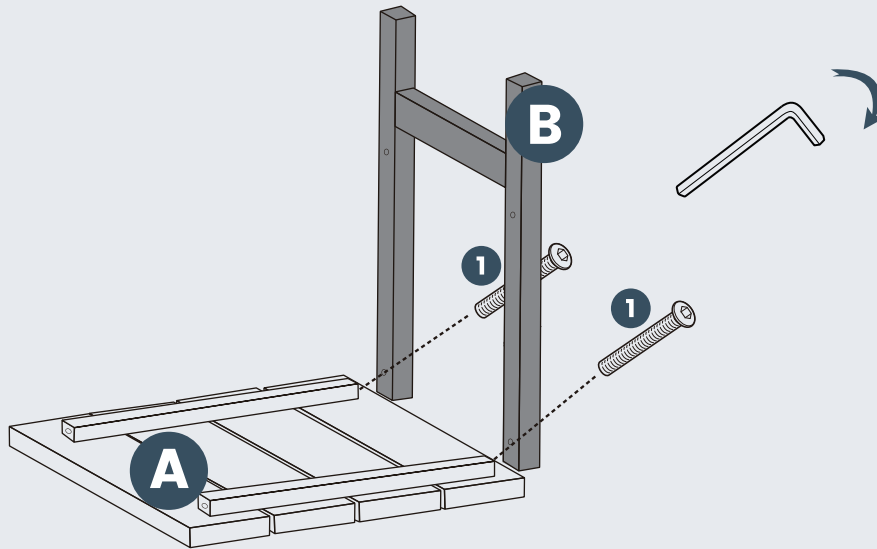

2

Attach **Part C Table Wooden Braces** to **Part B Chair Legs** with 2 pcs of **Hardware #1 Bolt**.

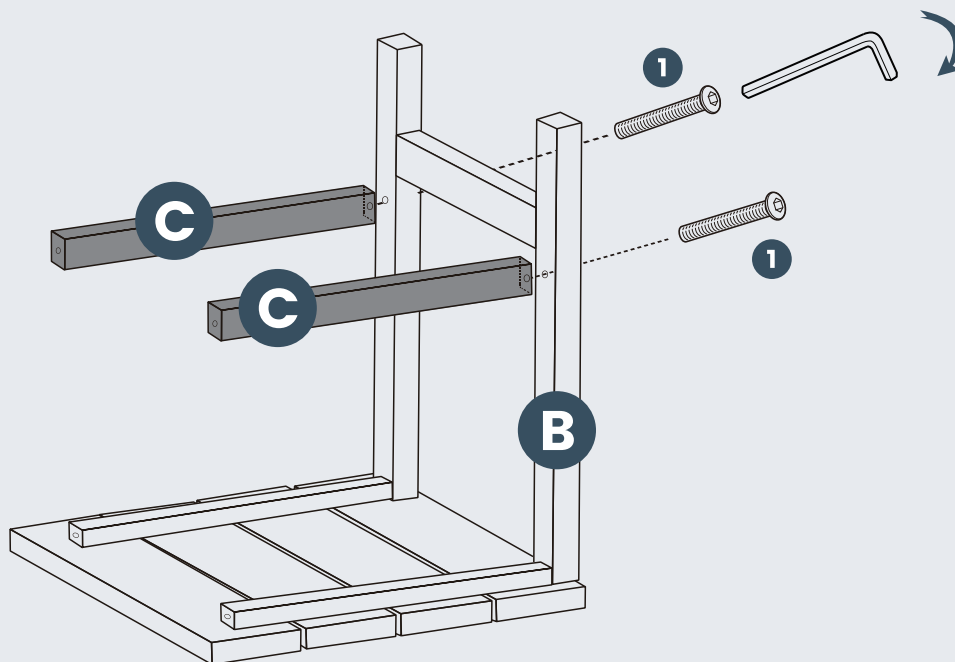

PRODUCT ASSEMBLY

3

Attach **Part B Table Leg** to **Part A Table Top** and **Part C Wooden Brace** with 2 pcs of **Hardware #1 Bolt** using an **Allen Wrench**.

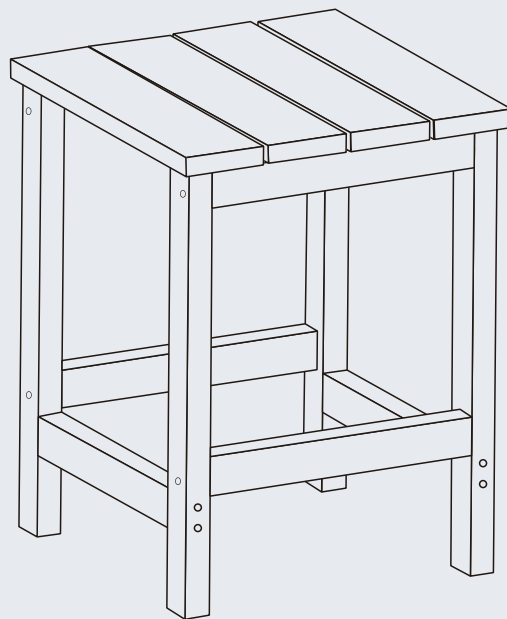
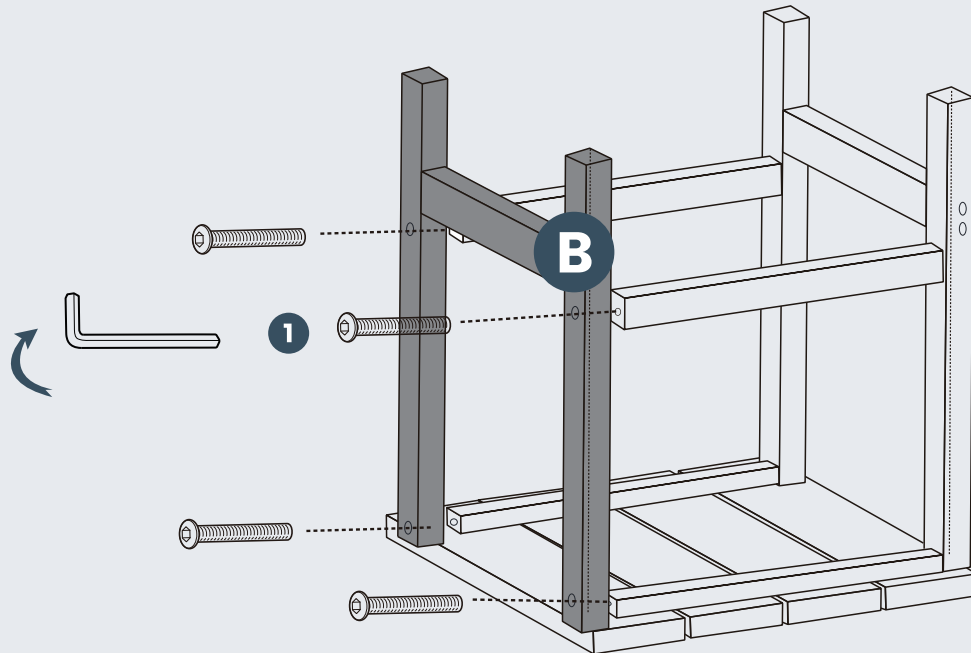

CLEANING TIPS

REGULAR CLEAN: Use a mixture of warm water and mild soap. Gently scrub the surface with a soft bristle brush to remove any dirt or stains.

QUICK CLEAN: You can simply wipe down the furniture with a damp cloth.

Regular cleaning not only preserves the aesthetic appeal of your furniture, but also helps extend its lifespan.