



IMPORTANT

Carefully remove all the parts from the carton and place them individually on a soft cloth to prevent scratches or other damage.

Carefully and strictly follow these assembly instructions to ensure a completed product as designed.

Do not use power tools above 8 volts to assemble.

Part List

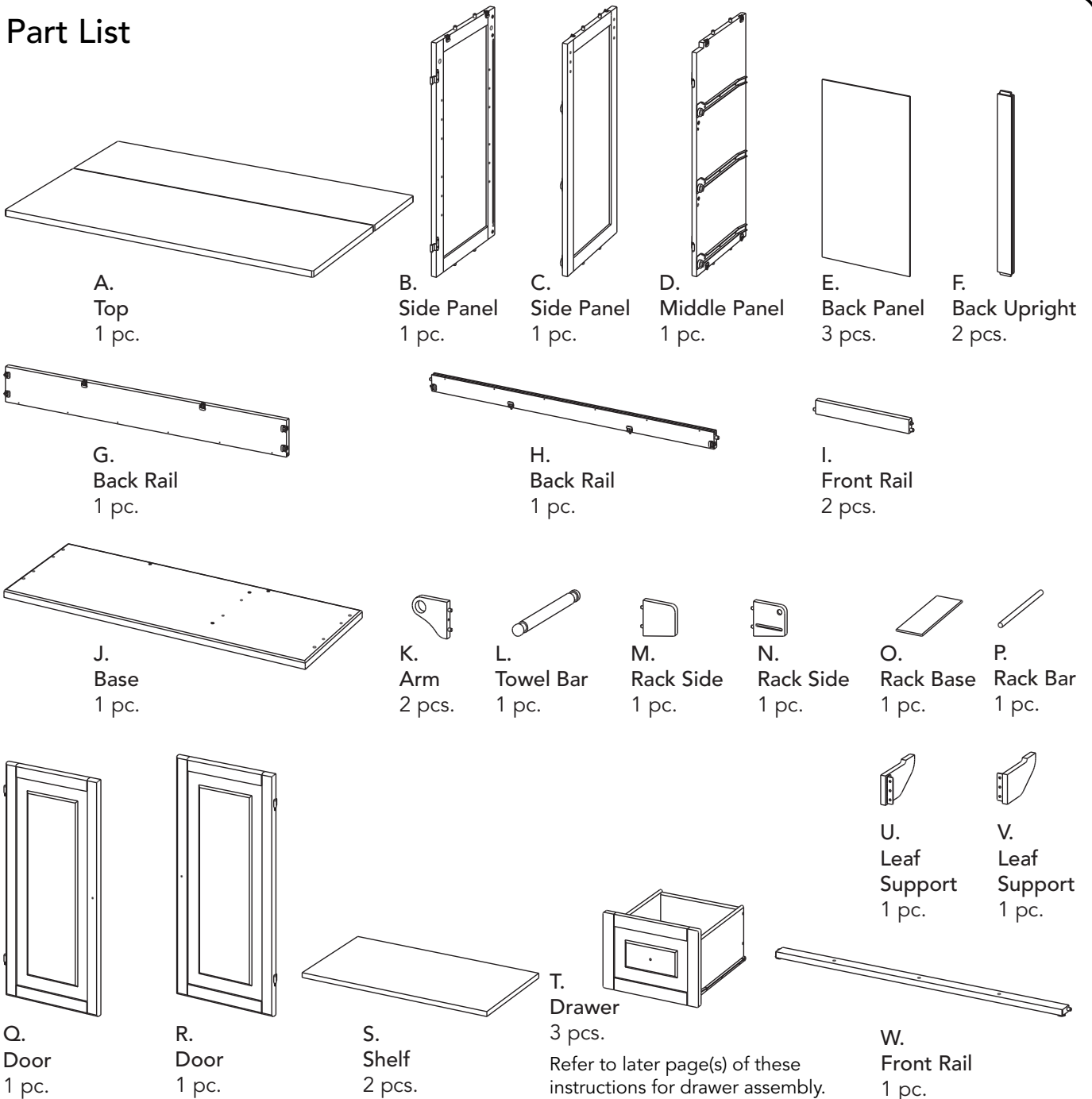

Tool(s) required for assembly: Phillips screwdriver

Assembly Instructions 2/9

Hardware List

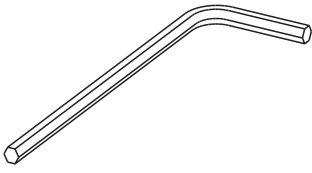

Hex Wrench
1 pc.

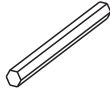

Small
Hex Wrench
1 pc.



01
Head Cap Bolt
4 pcs. (+1 extra)

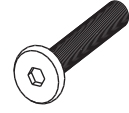

02
Head Cap Bolt (long)
4 pcs. (+1 extra)

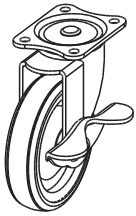

03
Locking Caster
2 pcs.

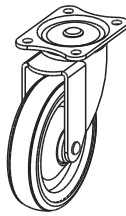

04
Non-Locking Caster
2 pcs.



05
Head Cap Bolt for Caster
16 pcs. (+1 extra)

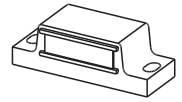

06
Magnet
2 pcs.



07
Wood Screw for Magnet
4 pcs. (+1 extra)



08
Knob
5 pcs.



09
Machine Screw
5 pcs.



10
Wood Screw (long)
24 pcs. (+1 extra)



11
Wood Screw (short)
24 pcs. (+1 extra)



12
Flat Head Screw
3 pcs. (+1 extra)

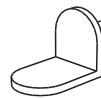

13
Adjustable Pin
8 pcs. (+1 extra)



14
Wood Screw for
Leaf Support
6 pcs. (+1 extra)

Assembly Instructions 3/9

IMPORTANT

- Use a soft cloth between these parts and the floor.
- Do not use power tools above 8 volts to assemble.
- Do not tighten all the bolts until each part is properly assembled.
- Keep Hex Wrench as the bolts may need to be tightened in the future.

STEP 1

Assemble Rack Sides (M), (N), Rack Base (O) and Rack Bar (P).

Note: Spice Rack and Towel Bar are interchangeable and may be installed on either side of the unit.

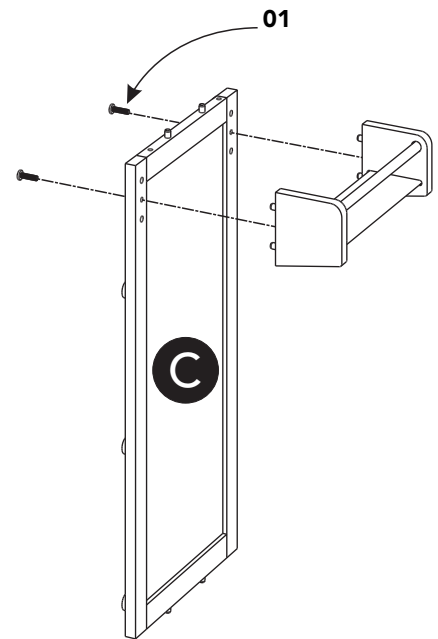
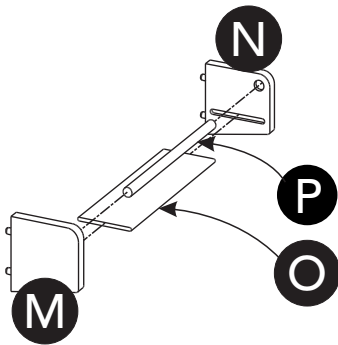

STEP 2

Attach unit to Side Panel (C) with 2 pcs. of **01**.

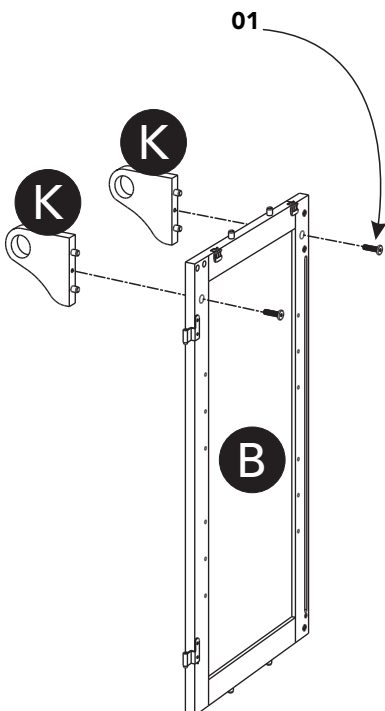

STEP 3

Attach Arms (K) to Side Panel (B) with 2 pcs. of **01**.

Assembly Instructions 4/9

STEP 4

Attach Back Rail (G) to Side Panel (C), then flip Locks. (See Figures 1 and 2)

Attach Back Uprights (F) to unit.

Slide Back Panels (E) into position.

Attach Back Rail (H) to unit, then flip Lock.

Attach Side Panel (B) to unit, then flip Locks.

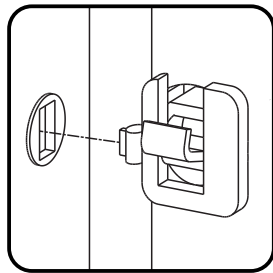
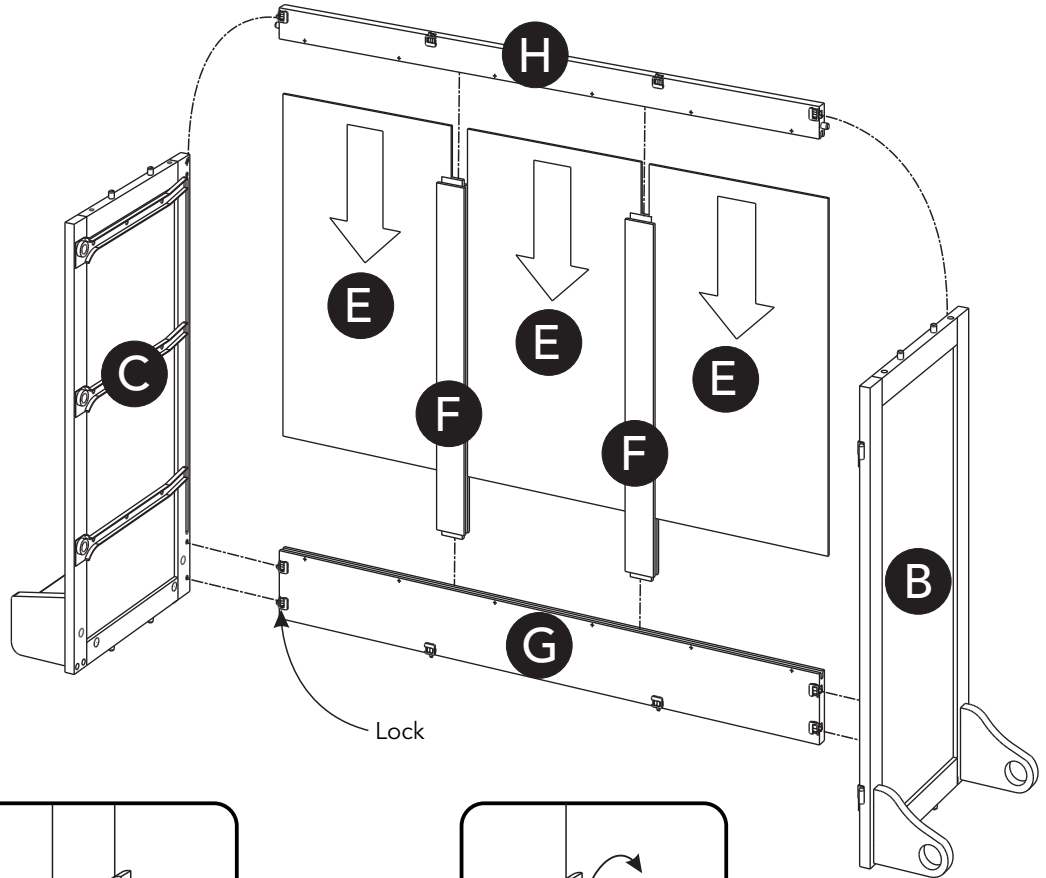

Figure 1

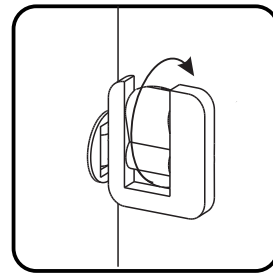
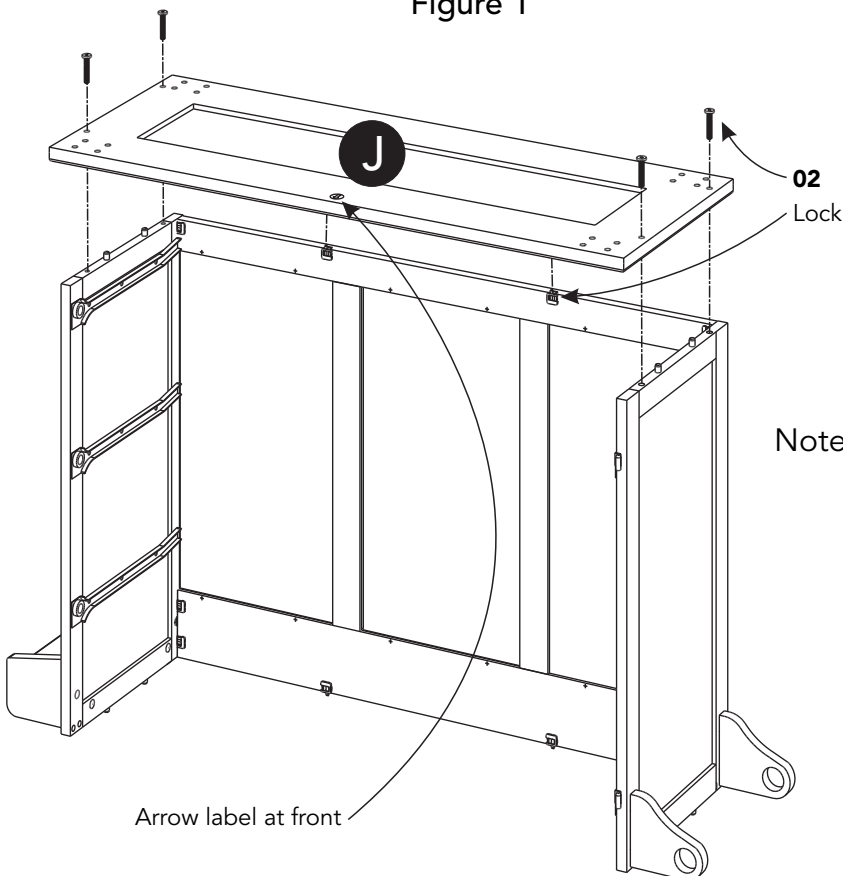

Figure 2



Arrow label at front

STEP 5

Attach Base (J) to unit with 4 pcs. of **02**. (See Figure 3)

Then flip Locks.

Note: Arrow label indicates front of Base (J).

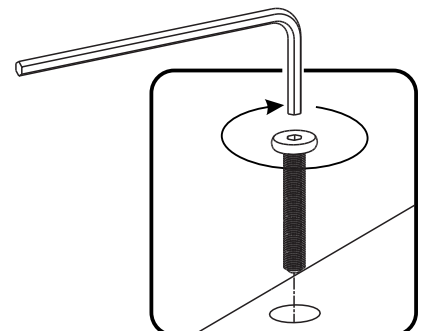

Figure 3

STEP 6

Attach 2 pcs. of **03** and 2 pcs. of **04** to unit with 16 pcs. of **05**.

Attach **03** at front.
(See Figure 4)

Note: Arrow label indicates front of unit.

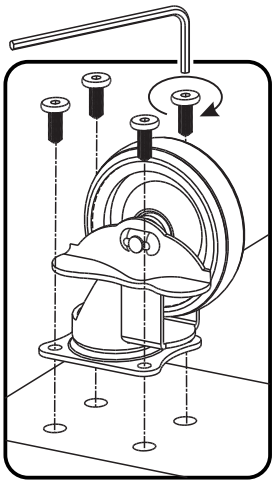
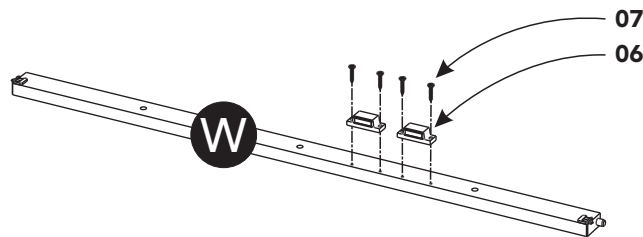
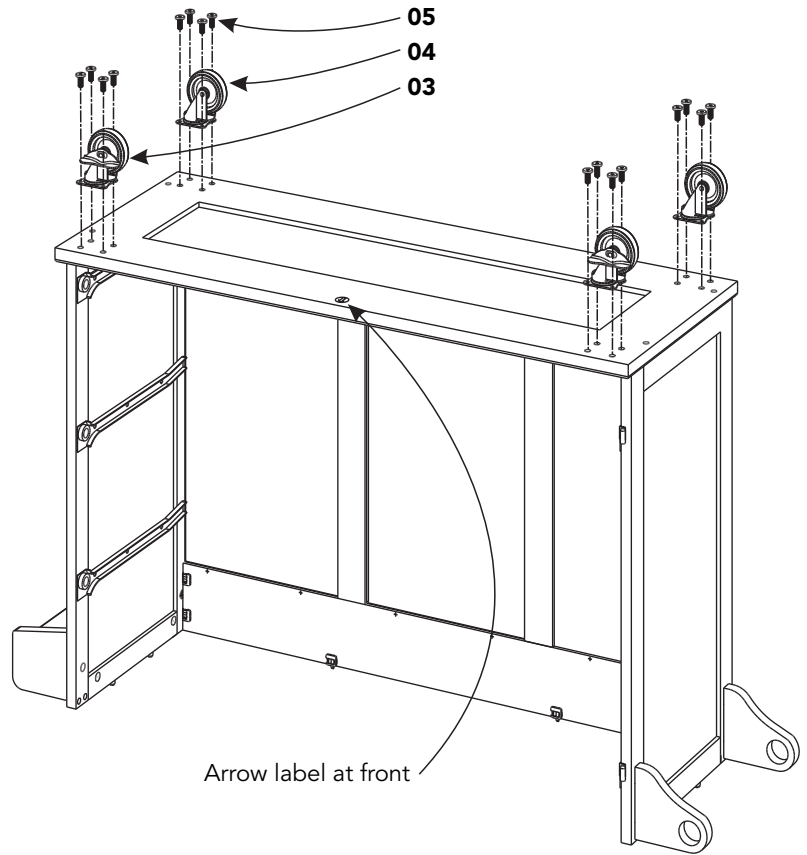

Figure 4



STEP 7

Attach 2 pcs. of **06** to Front Rail (W) by inserting 4 pcs. of **07** into pre-drilled holes, then tighten. (See Figure 5)

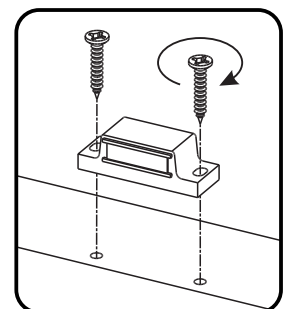

Figure 5

Assembly Instructions 6/9

STEP 8

Turn unit over to its upright position.

Attach Middle Panel (D) to unit, then flip Locks.

Attach Front Rails (I), (W) to unit, then flip Locks.

Slide Towel Bar (L) into position.

Attach Leaf Supports (U) and (V) to unit with 6 pcs. of **14**. (See Figure 6)

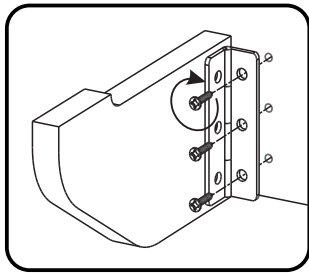
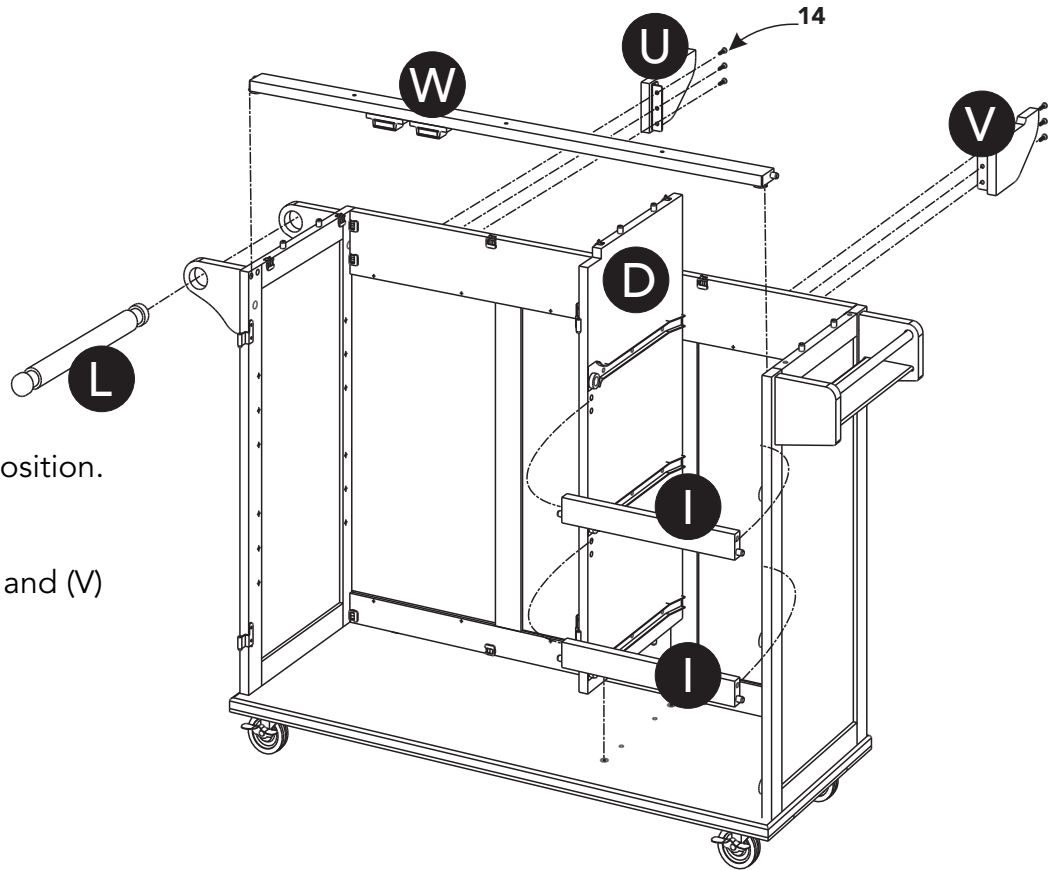

Figure 6

STEP 9

Attach Doors (Q) and (R) by sliding door hinges into side panel and middle panel hinges. (See Figure 7)

Attach 2 pcs. of **08** to Doors (Q) and (R) with 2 pcs. of **09**. (See Figure 8)

Attach Top (A) to unit, then flip Locks.

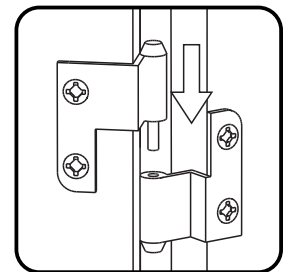
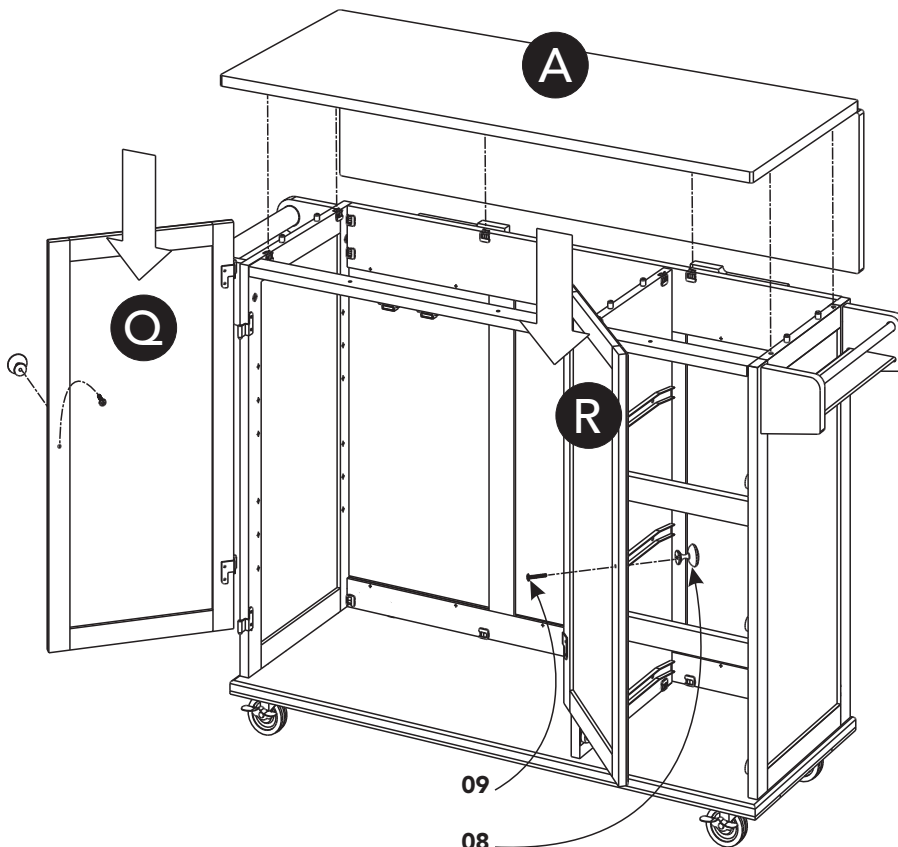

Figure 7

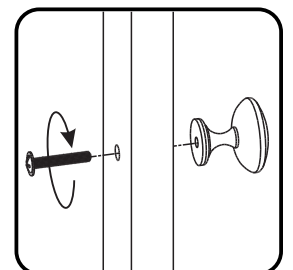
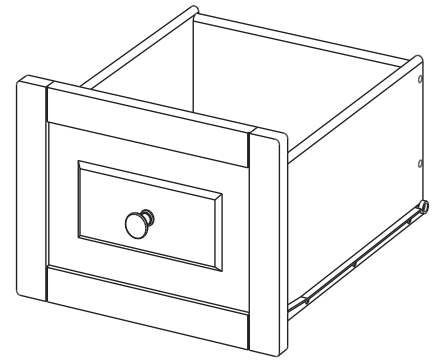
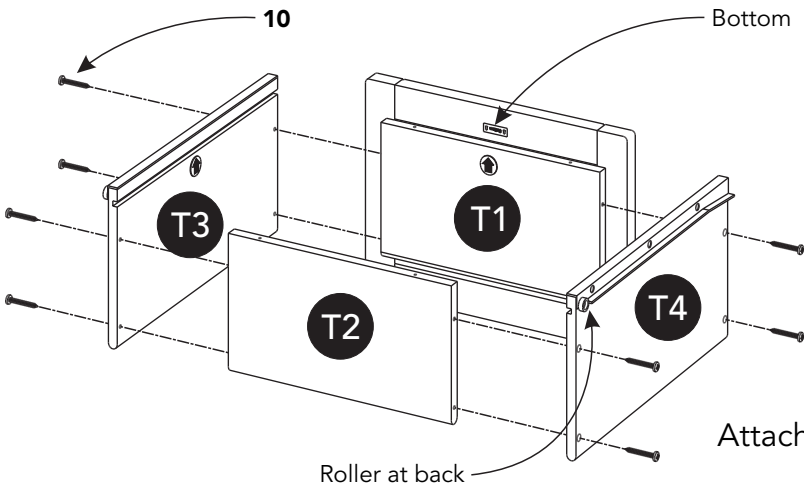

Figure 8

Assembly Instructions 7/9

Drawer (T)



STEP 10

Attach Drawer Front (T1) and Drawer Back (T2) to Drawer Side (T3) with 4 pcs. of **10**.

Attach Drawer Side (T4) to unit with 4 pcs. of **10**.

STEP 11

Slide Drawer Bottom (T5) into groove.

Attach Drawer Bottom (T5) to unit with 4 pcs. of **11**.

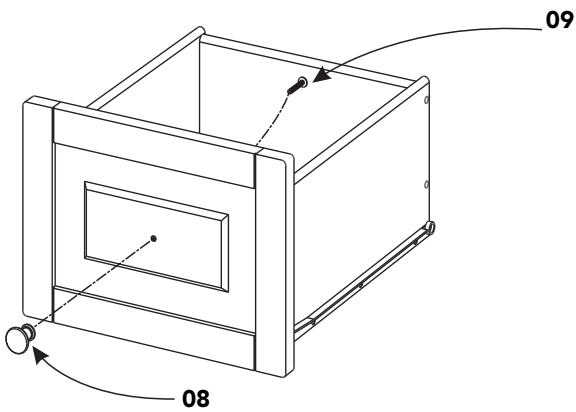
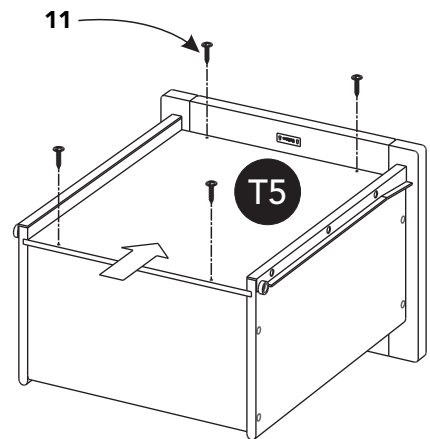

STEP 12

Attach a **08** with a **09**.

Part List

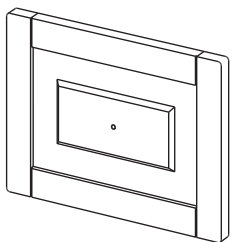

T1.
Drawer Front
3 pcs.

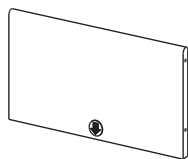

T2.
Drawer Back
3 pcs.

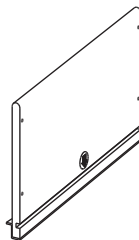

T3.
Drawer Side
3 pcs.

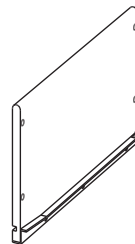

T4.
Drawer Side
3 pcs.

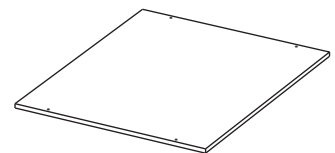

T5.
Drawer Bottom
3 pcs.

Assembly Instructions 8/9

STEP 13

Close the doors, then adjust doors gaps look proportional by move the unit
(See Figure 9)

Open the doors slowly.

Insert 12 pcs. of **11** into pre-drilled holes in unit, then tighten.

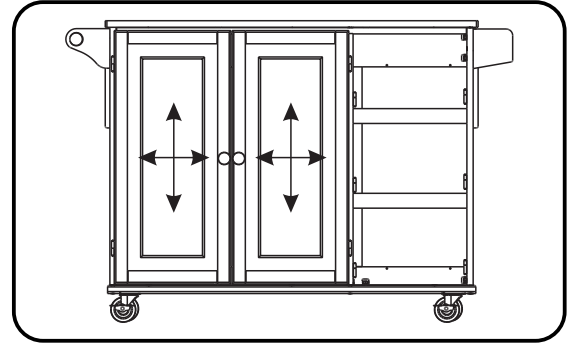
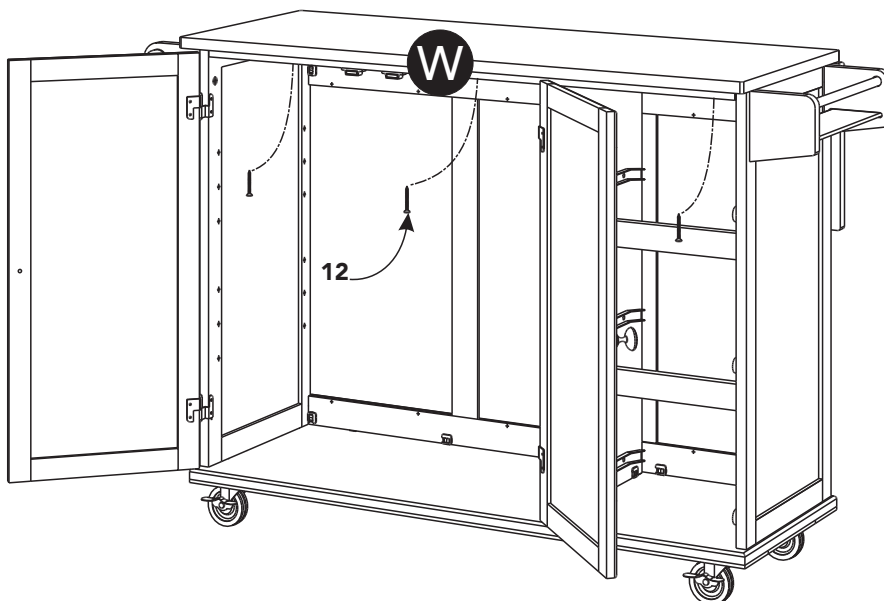
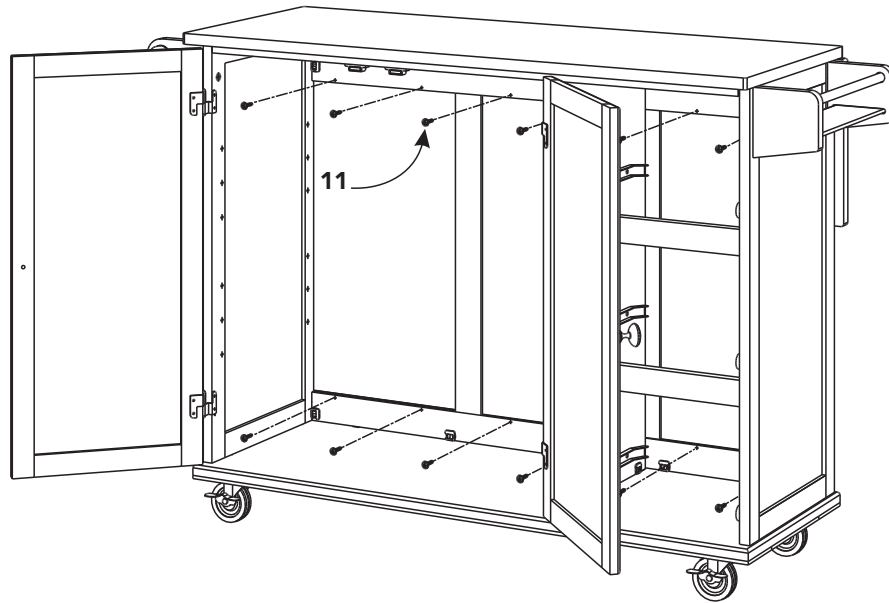
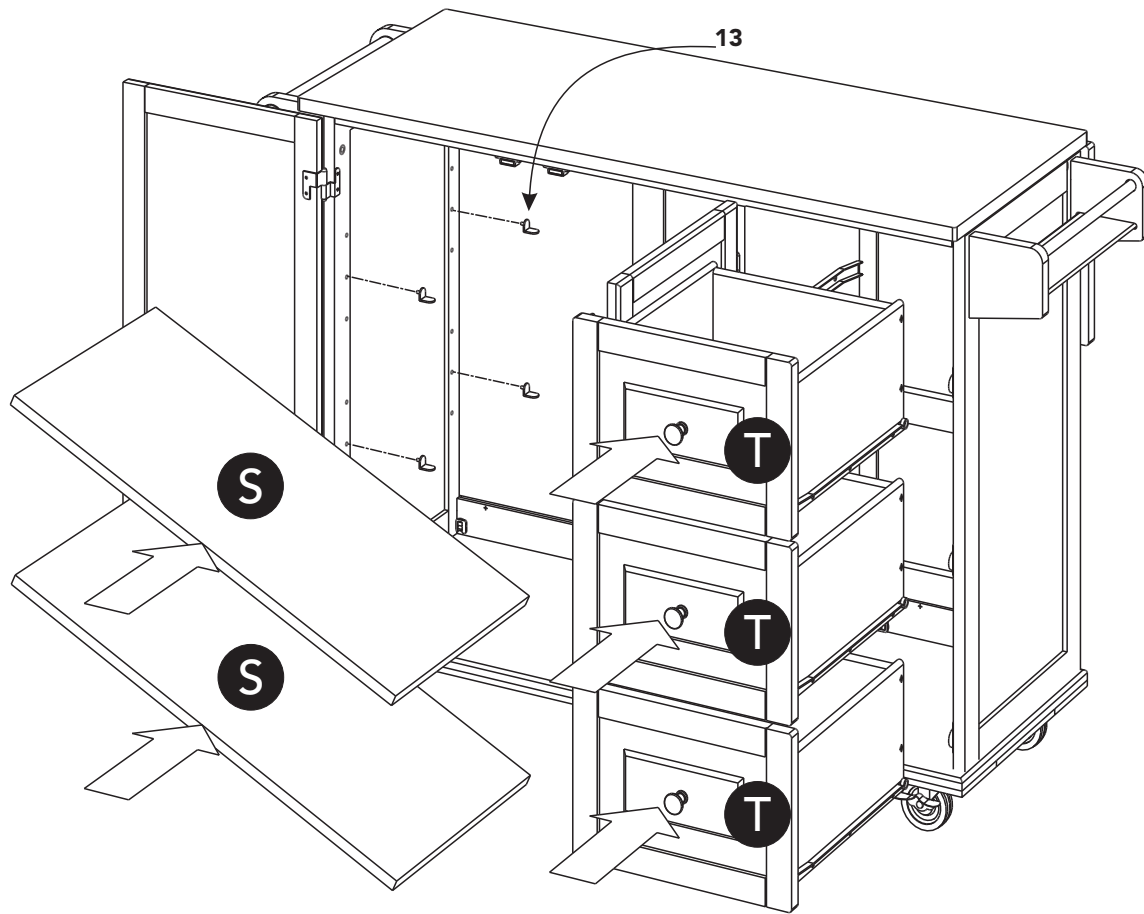

Figure 9



STEP 14

Insert 3 pcs. of **12** into pre-drilled holes of Front Rail (W), then tighten.



STEP 15

Insert 8 pcs. of **13** into side panel and middle panel at desired level.
(See Figure 10)

Place Shelves (S) into position.

Slide Drawers (T) into position.

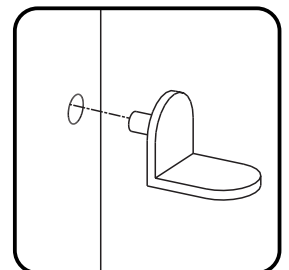

Figure 10

CARE INSTRUCTIONS

NEVER

allow liquids to remain on furniture.
Absorption causes parts to warp
and split and finishes to delaminate.

NEVER

use glass cleaners on
finished furniture. Ammonia
chemically attacks the finish.



Do not use power tools
above 8 volts to assemble.

**PREVENT
CRACKING**

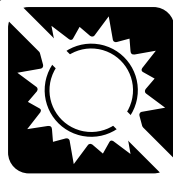

Do not place
in direct sunlight.

**PREVENT
FADING**



Do not write
directly on surface.

**PREVENT
MARKING**



Do not place hot
objects on surface.

**PREVENT
FINISH DAMAGE**

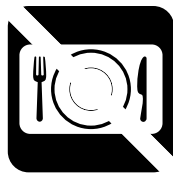

Do not use rubber
based placemats.

**PREVENT
DISCOLORING**



Do not use commercial
waxes and polishes.

**PREVENT
YELLOWING**

CLEAN

with a soft cloth moistened
in lukewarm soap and water.
Buff with a dry clean cloth.



homestyles will provide replacements free of charge for missing or damaged parts within 30 days of purchase. Digital images of the defective parts may be required. If the product was not purchased from an authorized retailer, **homestyles** is under no obligation to provide replacement parts. Parts are not available for fully assembled items nor are parts available for sale. Replacements for missing or damaged parts may be requested via contact info below.

homestyles Customer Service: www.homestylesfurniture.com,
servicedesk@homestylesfurniture.com, 888-680-7460