

CUSTOMER DRAWING

This drawing is the property of Rev-A-Shelf (RAS) and is disclosed in confidence to the extent its subject matter is original to RAS. Any vendor receiving this drawing from RAS shall hold and use this drawing for the sole benefit of RAS and shall not disclose it to, or use or reproduce it for any third party, or perform any act adverse to the interest of RAS with respect to this drawing without the express written permission of RAS. Vendors shall not revise any physical, dimensional or performance characteristic unless authorized by Rev-A-Shelf Engineering.

REV.	DATE	BY	DESCRIPTION OF CHANGE

INCH [MM]		AMERICAN PROJECTION	BY	DATE	
		DRAWN	JOE	21.04.26	
TOLERANCES MAT. (WOOD) .XX ± .03 [.8mm] (OTHER) .XX ± .02 [.5mm] (ALL) .XXX ± .005 [.13 mm] FRACTIONS ± 1/32 [.8 mm]		DEC.	ANGLES	MATERIAL	DRAWING NO.
FINISH		± 1/2	SCALE	1:10	SHEET OF
PART NO. 53PSP-18SC-FOG		SIZE TWO-TIER 18" BLIND CORNER B OPTIMIZER W/ SOFT CLOSE		SHEET OF 1 2	

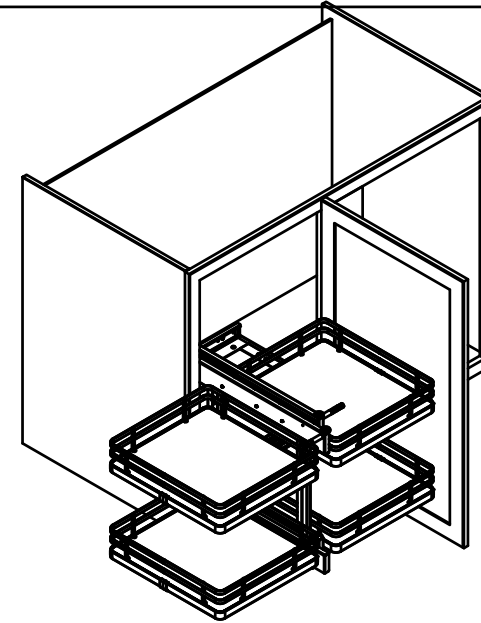
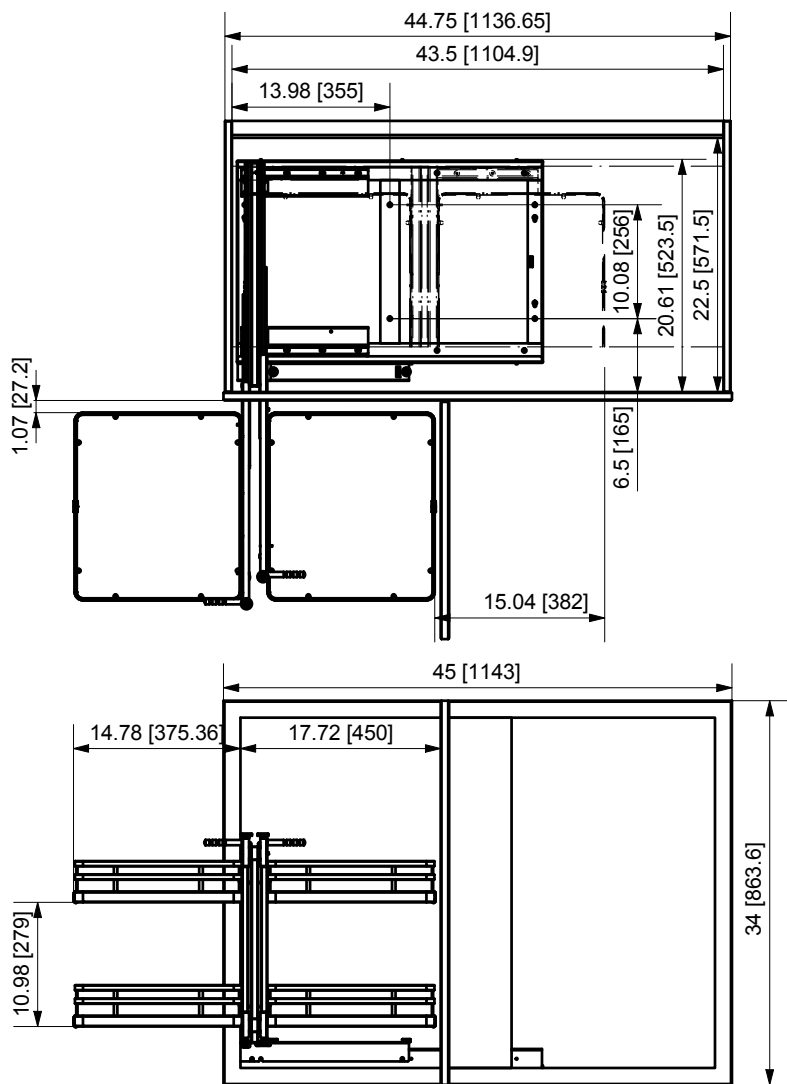

PART DIMENSIONS		
	MIN	MAX
WIDTH	32.25[819]	37.76[959]
DEPTH	20.40[518.2]	39.92[1014]
HEIGHT	21[533]	21[533]
WEIGHT		
DIAMETER		
RADIUS		
CONTAINER		
CAPACITY		
CONTAINER UOM		

MIN CABINET OPENING	
WIDTH	18.00[457]
DEPTH	21.66[550]
HEIGHT	22.00[559]

PRODUCT MAX WEIGHT RATING	

SLIDE SPECIFICATIONS				
SLIDE TYPE	BALL BEARING	SLIDE EXTENSION	19.69 [500]	MAX WEIGHT RATING
SLIDE CLOSING	SOFT CLOSE	SLIDE LENGTH	19.76 [502]	
SLIDE MOUNTING	FLOOR	SLIDE FINISH	ZINC	100LB

CUSTOMER DRAWING

This drawing is the property of Rev-A-Shelf (RAS) and is disclosed in confidence to the extent its subject matter is original to RAS. Any vendor receiving this drawing from RAS shall hold and use this drawing for the sole benefit of RAS and shall not disclose it to, or use or reproduce it for any third party, or perform any act adverse to the interest of RAS with respect to this drawing without the express written permission of RAS. Vendors shall not revise any physical, dimensional or performance characteristic unless authorized by Rev-A-Shelf Engineering.

REV.	DATE	BY	DESCRIPTION OF CHANGE

INCH [MM]	AMERICAN PROJECTION	BY	DATE	
		DRAWN	JOE 21.04.26	
				SCALE
MAT. (WOOD) .XX ± .03 [.8mm] (OTHER) .XX ± .02 [.5mm] (ALL) .XXX ± .005 [.13 mm] FRACTIONS ± 1/32 [.8 mm]		MATERIAL		DRAWING NO.
		FINISH		PART NO.
				SHEET OF
				53PSP-18SC-FOG 2 2