



IGNITE - 60"  
BASKETBALL SYSTEM

MODEL NO.  
**B2256**



**Please Do Not Return This Product to the Store!**

Contact Escalade® Sports customer service department at:  
Phone: 1-888-USA-GOAL Toll-Free!  
Fax: 1-866-873-3536 Toll-Free!  
E-mail: [customerservice@escaladesports.com](mailto:customerservice@escaladesports.com)



Escalade® Sports products may be manufactured and/or licensed under the following patents.  
6120397, 5816957, 5769744, 5119741, 4911085, 4717157, D460140, D420563, 8414431  
Additional patents may be pending. One or more of the listed patents and/or pending patents may cover specific product.

# PRE - ASSEMBLY TIPS

- 1. Read this manual carefully before starting assembly.** Read each step completely before beginning each step.
- 2. Some smaller parts may be shipped inside larger parts. Check inside all parts and cartons before assembling or ordering parts.**
- 3. To make assembly easier, use the Hardware Identifier on page 7-9 to identify and sort all fasteners. Check all cartons for kits. All hardware may not be located in one kit.**
- 4. Do not tighten hardware until instructed to do so. If hardware is tightened too soon, mounting holes may not align and parts may not easily fit together. Leave locknuts slightly loose until you are instructed to tighten them.**
- 5. Save these instructions and your proof of purchase (receipt) in the event that the manufacturer has to be contacted for replacement parts.**

### ITEMS NEEDED (NOT INCLUDED)

- |   |  |
|---|--|
| 11 - 80 lb. bags of concrete                                      | 1 - 5/16" socket driver for cordless drill (used to assemble Board Pads) |
| 1 - Post hole digger (optional)                                   | 1 - 7/32" Hex Key (included)   |
| 1 - Concrete form (see note after step 2)                         | 1 - wheel barrow   |
| 1 - 1/2" Open end Wrench  | 1 - garden hose  |
| 1 - 1/2" Socket & Ratchet (optional)                              | 1 - Phillips Screwdriver   |
| 1 - 15/16" Open end Wrench  | 1 - Level  |
| 1 - 15/16" Socket and Ratchet (optional)                          | 1 - Tape Measure   |
| 1 - 9/16" Deep Well Socket & Ratchet                              | 1 - Rubber Mallet  |
| 1 - 9/16" Open end Wrench   | 1 - Set of Padded Saw Horses   |
| 1 - 3/4" Socket and Ratchet (optional)                            | 1 - Safety glasses   |
| 1 - 3/4" Open end Wrench  | 1 - Ladder   |
| 1 - Cordless drill & 9/64" drill bit                              |  |
| 2 -7/16" Open end Wrench or 1 open end wrench & adjustable wrench |  |

### Please Do Not Return This Product To The Store!

Contact Escalade® Sports customer service department at:

Phone: 1-888-USA-GOAL Toll – Free !

Fax: 1-866-873-3536 Toll – Free !

E-mail: basketball@escaladesports.com

Mailing Address (correspondence only):

Escalade Sports  
 PO Box 889  
 Evansville, IN 47706

Please visit our Website at:  
[www.escaladesports.com](http://www.escaladesports.com)

ON-LINE TROUBLE SHOOTING TECHNICAL ASSISTANCE  
 ON-LINE PARTS REQUESTS FREQUENTLY ASKED QUESTIONS  
 ADDITIONAL ESCALADE®SPORTS PRODUCT INFORMATION





# SAFETY INSTRUCTIONS



**FAILURE TO FOLLOW THESE WARNINGS MAY RESULT IN SERIOUS INJURY AND/OR PROPERTY DAMAGE.**

**Owner must ensure that all players know and follow these rules for safe operation of the system.**



## WARNING

**FAILURE TO FOLLOW THESE WARNINGS MAY RESULT IN SERIOUS INJURY AND/OR PROPERTY DAMAGE.**

**Owner must ensure that all players know and follow these rules for safe operation of the system.**

- Do not dunk on this unit
- Do not hang from any part of the unit, including the backboard, rim, support braces, or net.
- Do not slide, climb, or play on pole.
- Keep organic material away from pole base. Grass, litter, etc. could cause corrosion and/or deterioration.
- Check pole system for signs of corrosion (rust, pitting, chipping). Remove rust and/or loose paint completely and repaint with exterior enamel paint. If rust has penetrated through the steel anywhere, replace pole immediately.
- Check system before each use for proper ballast, loose hardware, excessive wear, and signs of corrosion and repair before using.
- During play, use extreme caution to keep players face away from the backboard, rim, and net. Serious injury could occur if teeth/face come in contact with backboard, rim, or net.
- Wear a mouth guard when playing to avoid dental injuries.
- When adjusting height, keep hands and fingers away from moving parts.
- During play, do not wear jewelry (rings, watches, necklaces, etc.). Objects may entangle in net.
- Do not allow children to adjust system.
- Check system before each use for instability.
- Never play on damaged equipment.

4L-7609-00



## SAFETY INSTRUCTIONS



**FAILURE TO FOLLOW THESE SAFETY INSTRUCTIONS MAY RESULT IN SERIOUS INJURY, PROPERTY DAMAGE AND WILL VOID WARRANTY.**

**Owner must ensure that all players know and follow these rules for safe operation of the system.**

**To ensure safety, do not attempt to assemble this system without following the instructions carefully. Proper and complete assembly, use and supervision is essential for proper operation and to reduce the risk of accident or injury. A high probability of serious injury exists if this system is not installed, maintained, and operated properly.**

- If using a ladder during assembly, use extreme caution.
- 4 people are recommended for this operation.
- Seat the pole sections properly (if applicable). Failure to do so could allow the pole sections to separate during play.
- Before digging contact utility company to locate underground power cables, gas and water lines. Ensure there are no overhead power lines within 20 ft. (7m) radius of pole location.
- Climate, corrosion or misuse could result in system failure.
- If technical assistance is required, contact the manufacturer.
- Minimum operational height is 6'6" (1.98m) to the bottom of backboard.

*Most injuries are caused by misuse and/or not following instructions.  
Use caution when using this system.*

# INSTALLATION TIMELINE

1. Prior to anchor system and goal assembly, call utility services for location of underground utility lines before you dig.
2. Vertical main post assembly is a two part process.

## PART 1

**Day 1.** Complete Anchor System Installation Instructions. (Below)

**Day 2-4.** Allow concrete to cure.

## PART 2

**Day 5.** Complete Goaliath® assembly instructions. (Requires four adults)

## ANCHOR SYSTEM INSTALLATION INSTRUCTIONS (Day 1)



**Before digging hole for anchor system, check for buried power, gas, water, and telecommunication lines! Failure to do so could result in serious or fatal injury! Contact your local utility company if unsure.**

### Items needed for Anchor Installation (not included)

- |   |                  |
|---|------------------|
| 9 - 80 lb. bags of concrete (2-3 extra recommended) | 1 - wheel barrow |
| 1 - post hole digger (optional)                     | 1 - garden hose  |
| 1 - 15/16" open end wrench                          | 1 - level        |
| 1 - 15/16" socket and ratchet (optional)            | 1 - tape measure |
| 1 - concrete form (see note after step 2)           |                  |

**Note: For best results with less vibration, anchor system should be independent of court. If pouring concrete for both at same time, add an expansion joint in between.**

**Note: When digging hole, if you hit rock and cannot dig through contact a contractor.**

1. Determine the location of the anchor system. The proper location is as close to the court without making contact, as shown in Figure 1. This, however, is a general rule. If you need to locate the anchor system in a location other than this, use the following dimensions as a guide.

Overhang when adjusted to 10 ft. = 26"

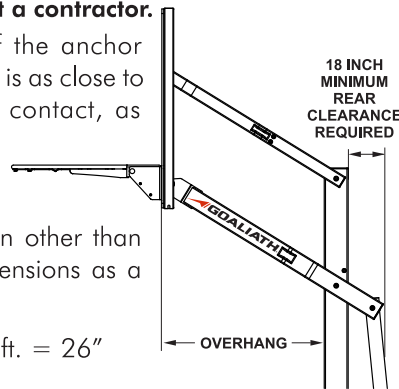

**Note: Minimum of 18" rear clearance is required behind pole.**

2. Assemble anchor system as follows: Thread nut (#45) to bottom of threads on anchor bolt (#50) insert threads of anchor bolt (#50) through hole on anchor plate (#49) and secure with nut (#45). Repeat this step for the remaining anchor bolts. See Figure 2. Note: Each leg of anchor bolts should face the anchor bolt to the right. See Detail A.

**Detail A  
Bottom View**

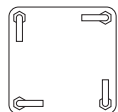

**Figure 2**

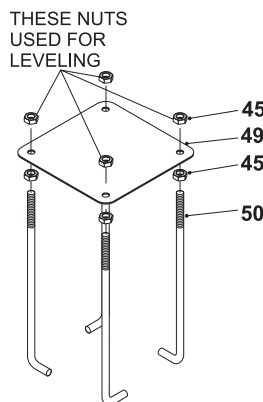

**Figure 1**

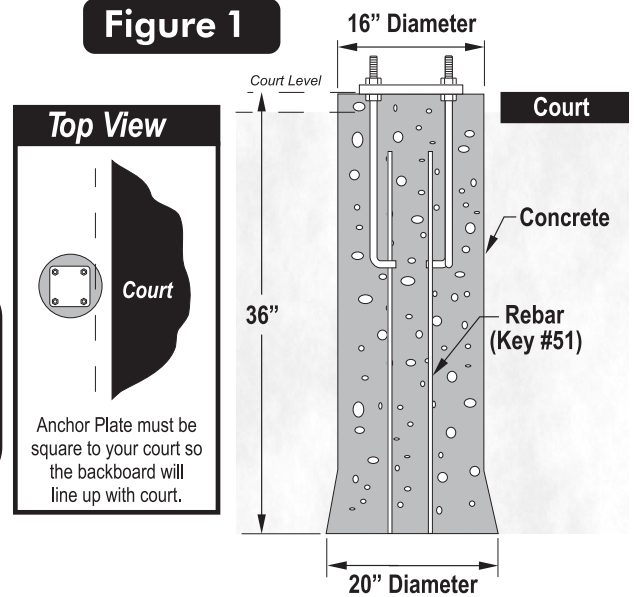

**Note: Using a concrete form for the top 4" of the concrete is recommended. Cardboard forms can be purchased at some hardware and home stores or a wooden form can be constructed out of 2 x 4's.**

**Note: Failure to dig and fill hole as instructed will result in increased system vibration.**

**\*Tip: It is always a good idea to purchase two or three extra bags of concrete, just in case you need them. If extra bags are not used you can return them to the store.**

3. Mix and pour concrete into hole. Follow instructions on concrete bag. Stop about 18" below court level.
4. Insert four reinforcement bars (#40) into concrete 8" apart creating a square in center on hole.
5. Finish pouring concrete up to court level.
6. Push anchor system into concrete and agitate to work out voids in concrete. Immediately use a level to level and square anchor plate to playing surface. Clean off any concrete that may be on exposed threads.

**Note: The bottom four nuts will be forever embedded in concrete. The top four nuts remain on bolts and are used for leveling. (See Page 25).**

Let concrete cure for a MINIMUM of 72 hours.

# PARTS LIST (NOT ACTUAL SIZE)

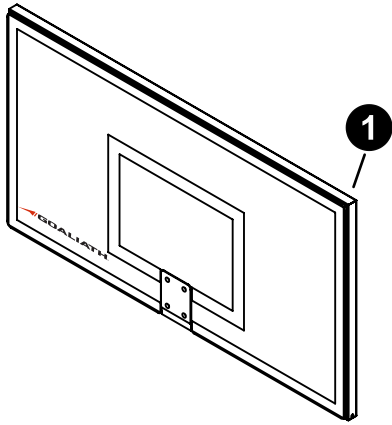

BACKBOARD ASSEMBLY, 60" X 33"  
6A-7799-10  
QTY. 1

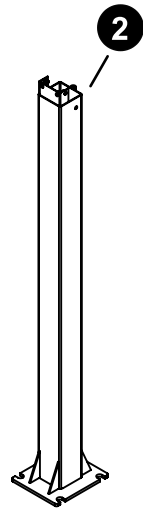

LOWER POLE  
1A-7961-10  
QTY. 1

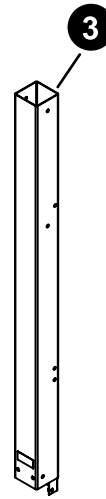

UPPER POLE  
1A-7962-10  
QTY. 1

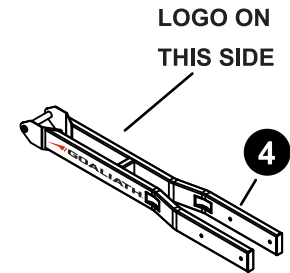

LOWER BOARD ARM ASSEMBLY  
with Godliath logo  
1A-7975-10  
QTY. 1

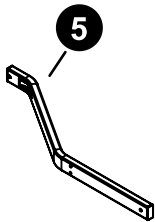

UPPER BOARD ARM ASSEMBLY  
1A-7963-10  
QTY. 2

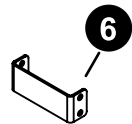

BRACE, BOARD ARM  
2S-9442-10  
QTY. 1  
(Packed together  
with parts #8,9 & 14)

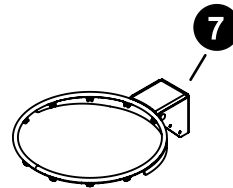

MEDIUM WEIGHT RIM  
6A-6374-01  
QTY. 1

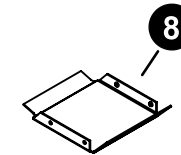

RIM COVER PLATE  
2S-6427-01  
QTY. 1  
(Packed together  
with parts #6,9 & 14)

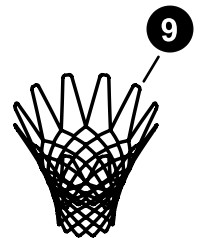

NET  
3F-6010-00  
QTY. 1  
(Packed together  
with parts #6,8 & 14)

**PARTS LIST (NOT ACTUAL SIZE)**

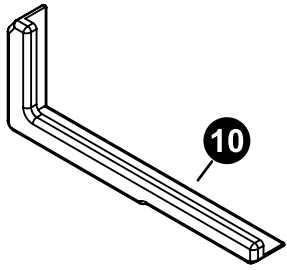

BOARD PAD, LH  
3M-6581-00  
QTY. 1

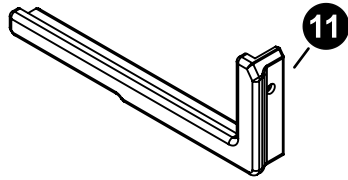

BOARD PAD, RH  
3M-6580-00  
QTY. 1

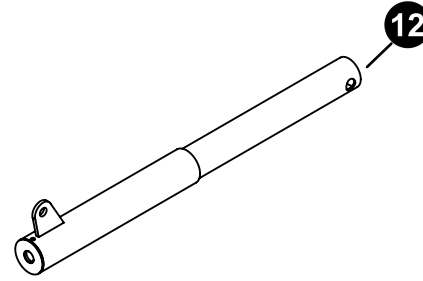

ACTUATOR  
4A-6605-00  
QTY. 1

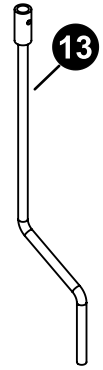

ACTUATOR HANDLE  
4A-6606-00  
QTY. 1

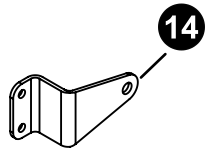

POST EAR  
2S-6795-02  
QTY. 2  
(Packed together  
with parts #6, 8 & 9)

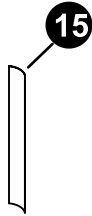

HEIGHT DECAL  
4L-8697-00  
QTY. 1  
(Packed with the owner's manual)

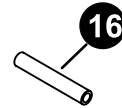

PIVOT TUBE  
8S-6658-00  
QTY. 1  
(Packed in hardware kit)

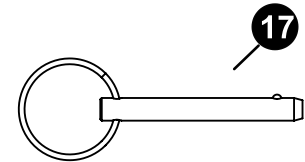

PULL PIN  
7B-6255-00  
QTY. 1  
(Packed with actuator handle)

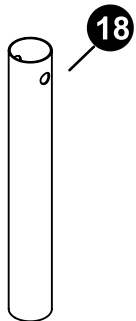

ACTUATOR SLEEVE  
3M-6542-00  
QTY. 1  
(Pre-assembled to part #12)

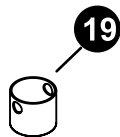

ACTUATOR CAP  
3M-8941-00  
QTY. 1  
(Pre-assembled to part #12)



TUBE PLUG, 4" SQUARE  
3M-6850-00  
QTY. 1  
(Pre-assembled to part #3)

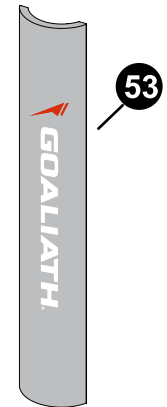

POST PAD  
3M-8960-00  
QTY. 1

# HARDWARE LIST (ACTUAL SIZE)

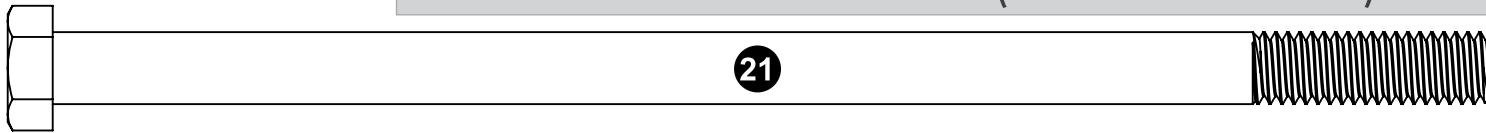

3/8 - 16 X 7.5 " HHCS, Grade 5  
1B-6483-10  
QTY. 2

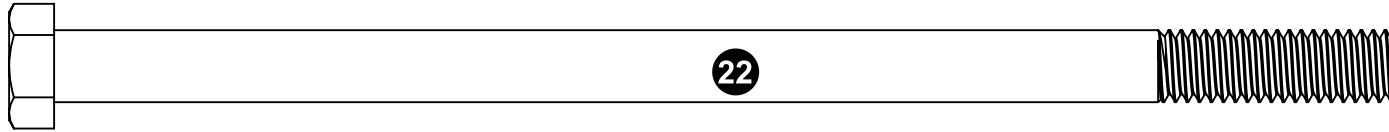

3/8-16 X 7.00 HHCS, ZINC GR 5  
1B-6484-10  
QTY. 2

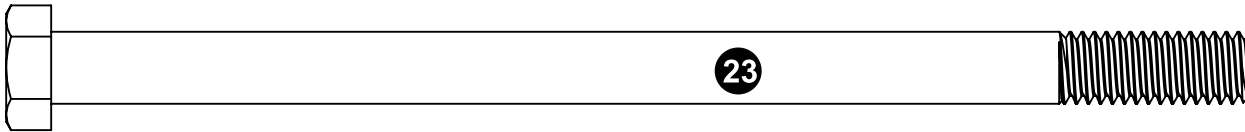

3/8-16 X 6.25" HHCS, GRADE 5  
1B-7188-00  
QTY. 1

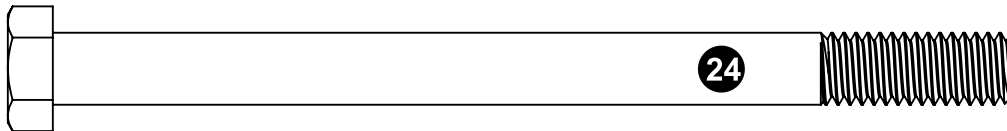

3/8-16 X 5" HHCS, GRADE 5  
1B-6485-10  
QTY. 2

**Note:** Base plate of Anchor kit is located at the bottom of hardware kit in the hardware carton.

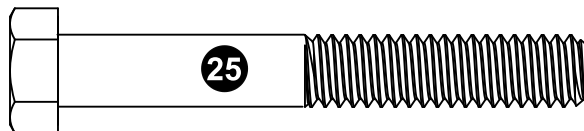

3/8-16 X 2 3/4" HHCS  
1B-6195-00  
QTY. 2

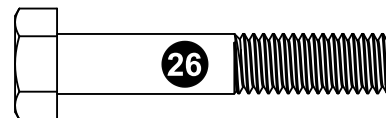

5/16-18 X 1.75 HHCS, ZINC  
1B-7190-00  
QTY. 4

# HARDWARE LIST (ACTUAL SIZE)

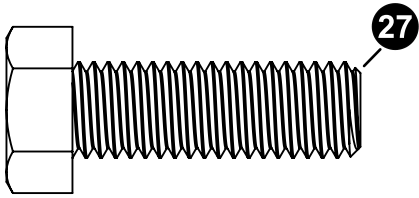

1/2-13 X 1 1/2" HHCS  
1B-6486-10  
QTY. 1

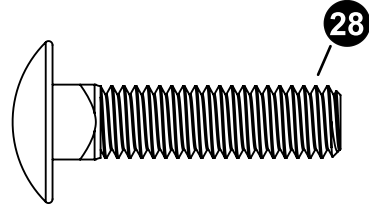

3/8-16 X 1.50 CB, ZINC  
1B-7187-00  
QTY. 4

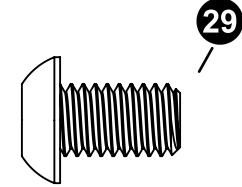

3/8-16 X .625 SBHS, STAINLESS STEEL  
1B-7189-00  
QTY. 8

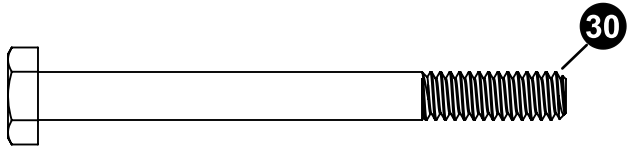

1/4-20 X 2.75 HHCS, ZINC  
1B-7196-00  
QTY. 1

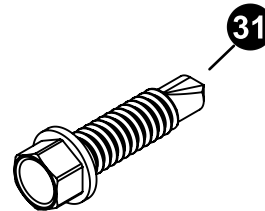

#10 X 1.0 ZINC SELF DRILLING /  
SELF TAPPING SCREW  
1B-6479-00  
QTY. 6

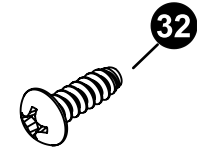

#8 X 1/2" SCREW  
1B-6788-00  
QTY. 4



# HARDWARE LIST (ACTUAL SIZE)

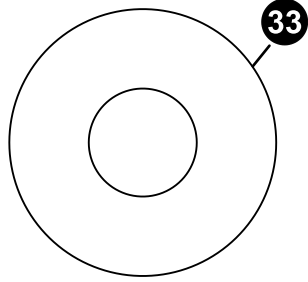

1/2" FLAT WASHER, ZINC  
2B-6093-00  
QTY. 2

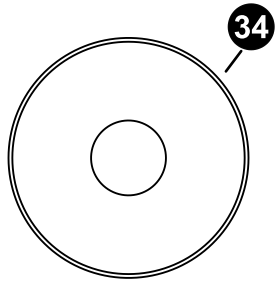

NYLON WASHER,  
0.38 ID X 1.25 OD  
3M-6883-00  
QTY. 8

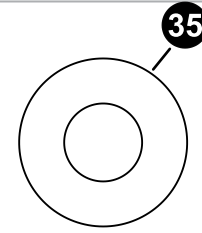

3/8 FLAT WASHER  
2B-6114-00  
QTY. 4

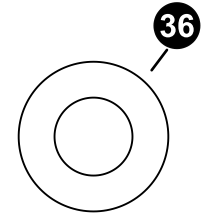

3/8" WASHER  
701-50  
QTY. 16

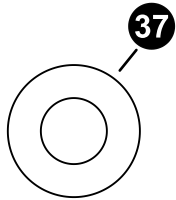

5/16" WASHER  
2B-6024-00  
QTY. 8

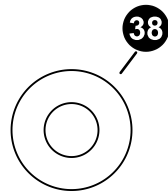

WASHER, 1/4" SAE FLAT  
2B-6014-00  
QTY. 2

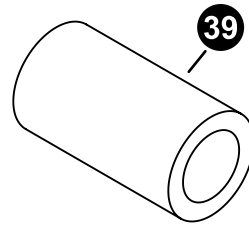

STOP SPACER  
8S-6657-00  
QTY. 2

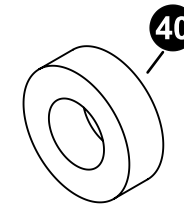

NYLON SPACER,  
0.4 ID X .78 OD X .25 THICK  
3M-6269-00  
QTY. 2

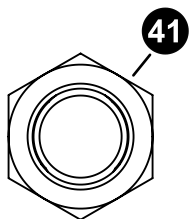

1/2-13 NUT NYLOK, ZINC  
2B-6095-00  
QTY. 1

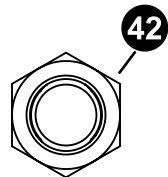

3/8-16 LOCKNUT  
901-28  
QTY. 13

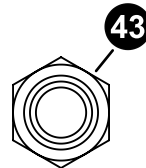

5/16-18 NUT NYLOK ZINC  
2B-6009-02  
QTY. 4

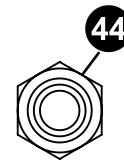

1/4-20 LOCKNUT, ZINC  
2B-6792-00  
QTY. 1

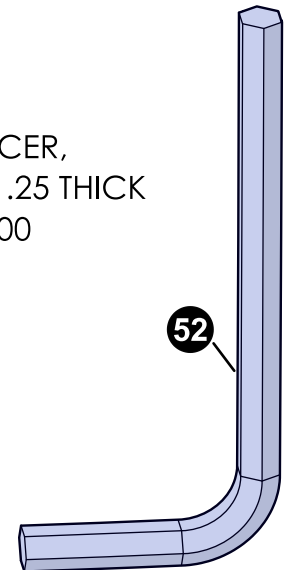

7/32" HEX KEY  
7B-8563-00  
QTY. 1

## HARDWARE LIST (ACTUAL SIZE)

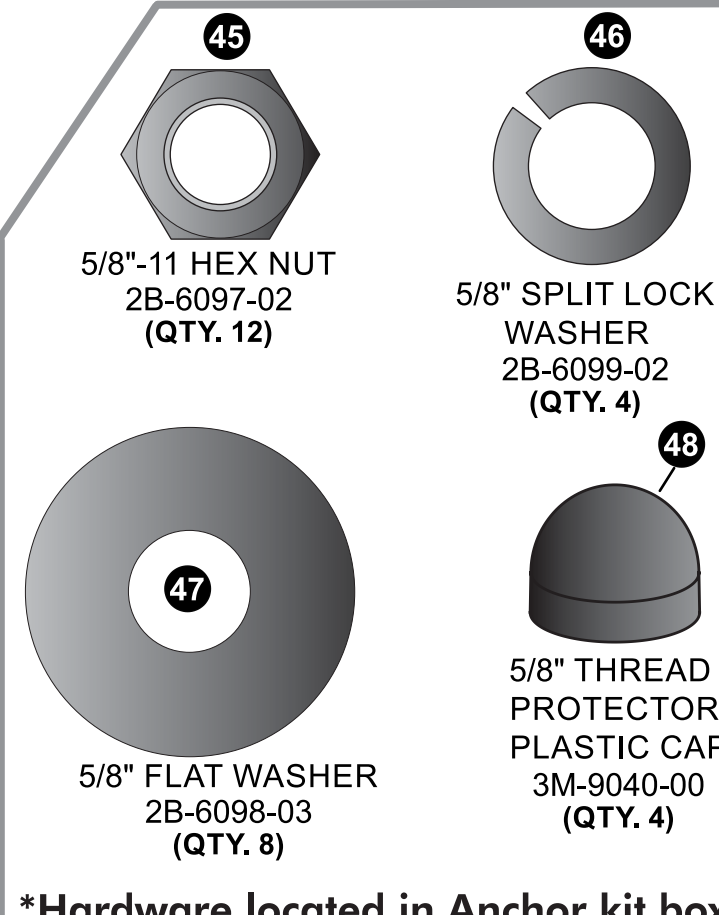

45  
5/8"-11 HEX NUT  
2B-6097-02  
(QTY. 12)

46  
5/8" SPLIT LOCK  
WASHER  
2B-6099-02  
(QTY. 4)

47  
5/8" FLAT WASHER  
2B-6098-03  
(QTY. 8)

48  
5/8" THREAD  
PROTECTOR  
PLASTIC CAP  
3M-9040-00  
(QTY. 4)

**\*Hardware located in Anchor kit box**

## PARTS LIST (NOT ACTUAL SIZE)

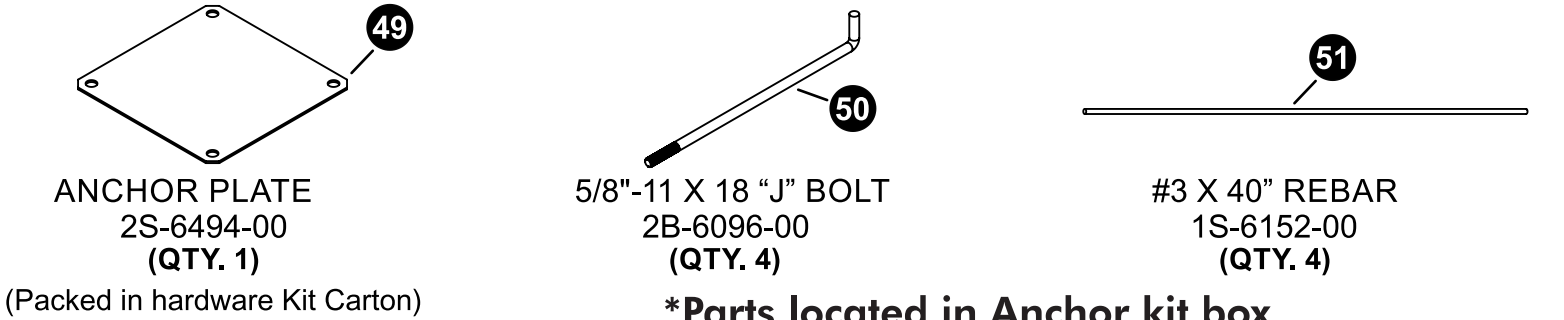

49  
ANCHOR PLATE  
2S-6494-00  
(QTY. 1)  
(Packed in hardware Kit Carton)

50  
5/8"-11 X 18 "J" BOLT  
2B-6096-00  
(QTY. 4)

51  
#3 X 40" REBAR  
1S-6152-00  
(QTY. 4)

**\*Parts located in Anchor kit box**

## HARDWARE NEEDED (ACTUAL SIZE)

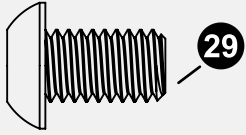

3/8-16 X .625 SBHS, STAINLESS STEEL  
1B-7189-00  
QTY.4



**KEEP CHILDREN AWAY FROM THE ASSEMBLY AREA. TWO CAPABLE ADULTS ARE NEEDED FOR THE FOLLOWING STEPS.**

### NOTE

WITH THE HELP OF ANOTHER ADULT CAREFULLY LIFT UPPER POLE (#3) AND SLIDE INTO LOWER POLE (#2). HOLES IN POLES SHOULD LINE UP WITH NO GAP BETWEEN POLES.



**PINCH POINTS! DO NOT** place your hand or any fingers in any of these locations when inserting the pole.

## TOOLS NEEDED



Packed in hardware kit.

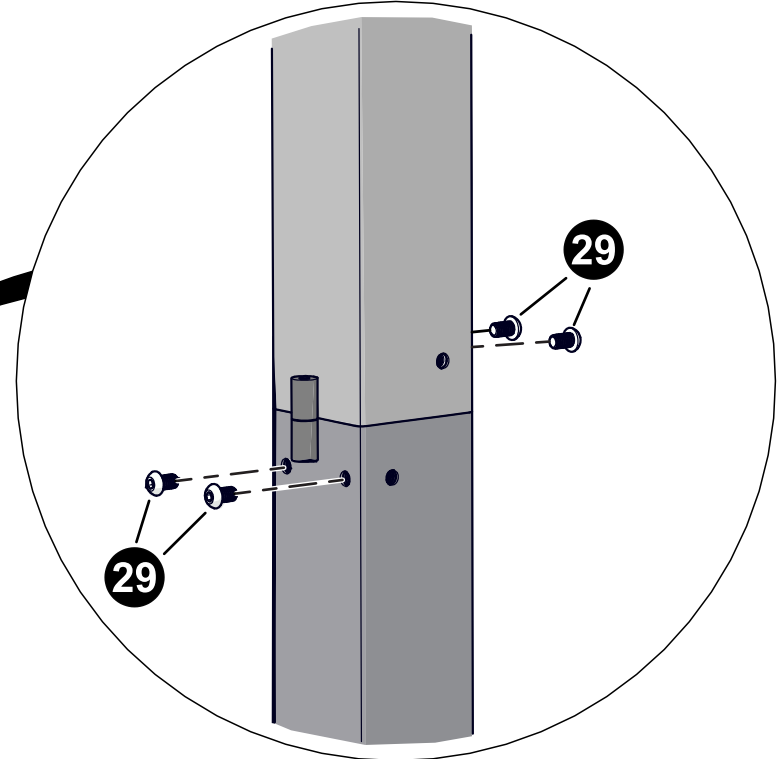
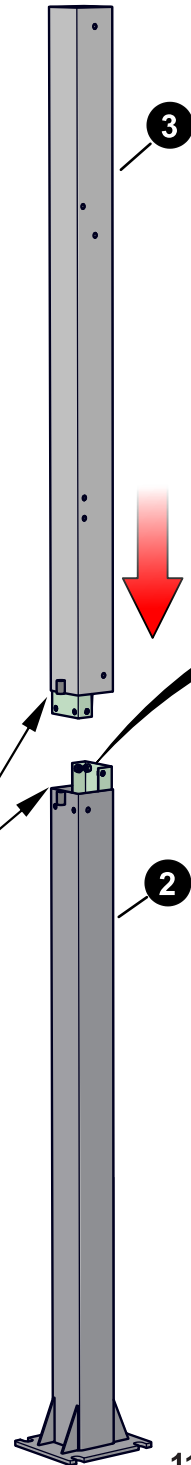

### NOTE

USE 7/32" HEX KEY WRENCH TO INSERT 2 FRONT BUTTON HEAD SCREWS AND 2 BACK BUTTON HEAD SCREWS (#29). TIGHTEN SCREWS COMPLETELY AT THIS TIME.

**HARDWARE NEEDED (ACTUAL SIZE)**

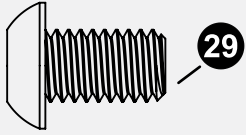

3/8-16 X .625 SBHS, STAINLESS STEEL  
1B-7189-00  
QTY.4



**KEEP CHILDREN AWAY FROM THE ASSEMBLY AREA.  
TWO CAPABLE ADULTS ARE NEEDED FOR THE  
FOLLOWING STEPS.**

**TOOLS NEEDED**



Packed in hardware kit.

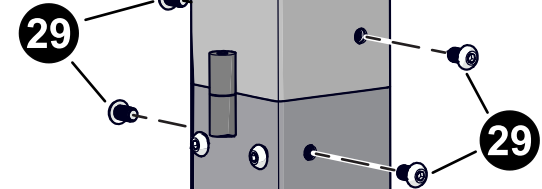
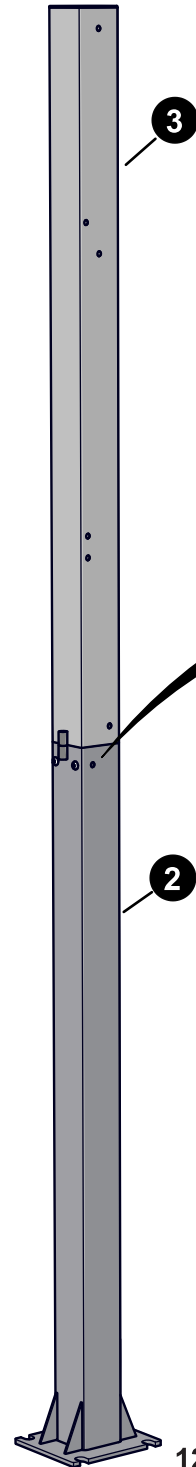

**NOTE**

USE 7/32" HEX KEY WRENCH TO INSERT 4 SIDE  
BUTTON HEAD SCREWS (#29). TIGHTEN  
SCREWS COMPLETELY AT THIS TIME.

**HARDWARE NEEDED (ACTUAL SIZE)**



1/4-20 X 2.75 HHCS, ZINC  
1B-7196-00  
QTY. 1

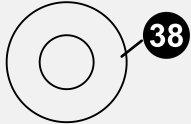

WASHER, 1/4" SAE FLAT  
2B-6014-00  
QTY. 2

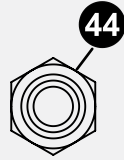

1/4-20 LOCKNUT, ZINC  
2B-6792-00  
QTY. 1

**TOOLS NEEDED**



7/32"

**TOOLS NEEDED**



7/16"

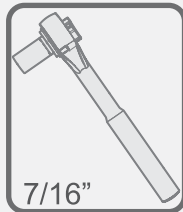

7/16"

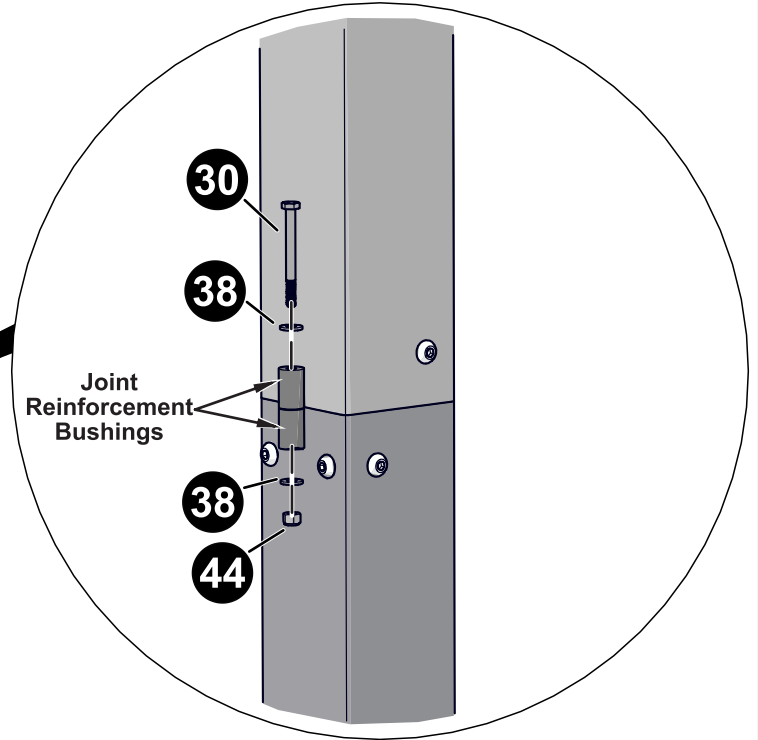
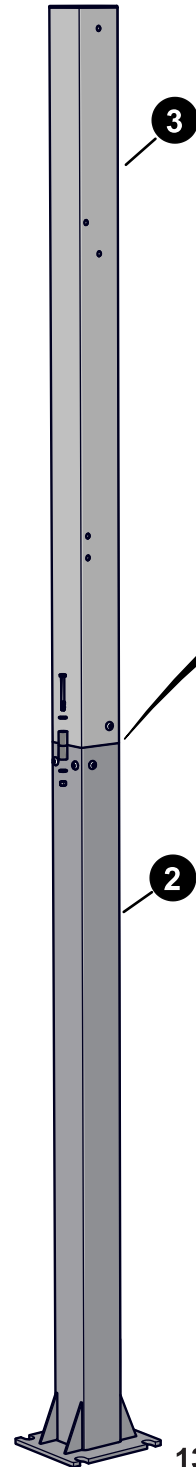

**NOTE**

INSTALL BOLT (#30), WASHERS (#38) AND NUT (#44)  
INTO JOINT REINFORCEMENT BUSHINGS AS SHOWN.  
TIGHTEN (#30) BOLT AND NUT (#44) UNTIL SECURE.

**NOTE:**

Prepare a flat area that is clear of debris. Keep children away from the assembly area. Two capable adults are needed for the following steps.

**CAUTION**  
MAKE SURE THAT THE POLE IS SECURE ON THE SAWHORSES AND NEVER LEAVE IT UNATTENDED.

**NOTE**  
PLACE POLE ASSEMBLY ON TWO SAWHORSES AS SHOWN.

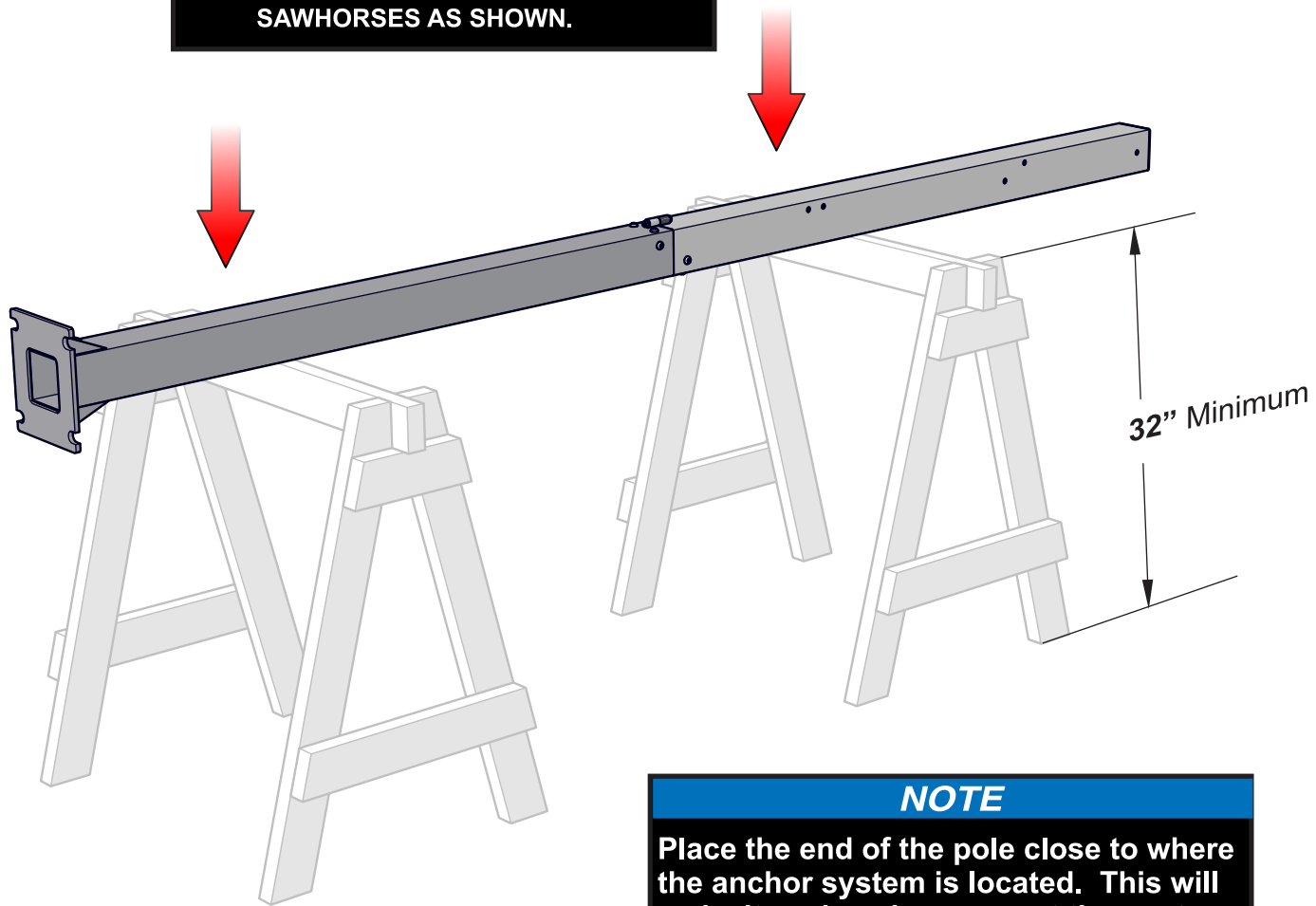

**NOTE**  
Place the end of the pole close to where the anchor system is located. This will make it easier when you set the post assembly upright.

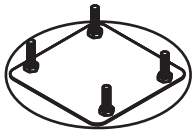

Previously installed Anchor System.

### TOOLS NEEDED



### HARDWARE NEEDED (ACTUAL SIZE)



3/8-16 X 5" HHCS, GRADE 5  
1B-6485-10  
QTY. 2

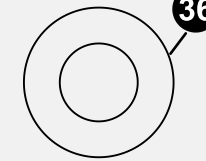

3/8" WASHER  
701-50  
QTY. 4

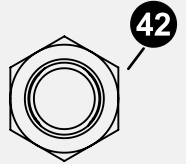

3/8-16 LOCKNUT  
901-28  
QTY. 2

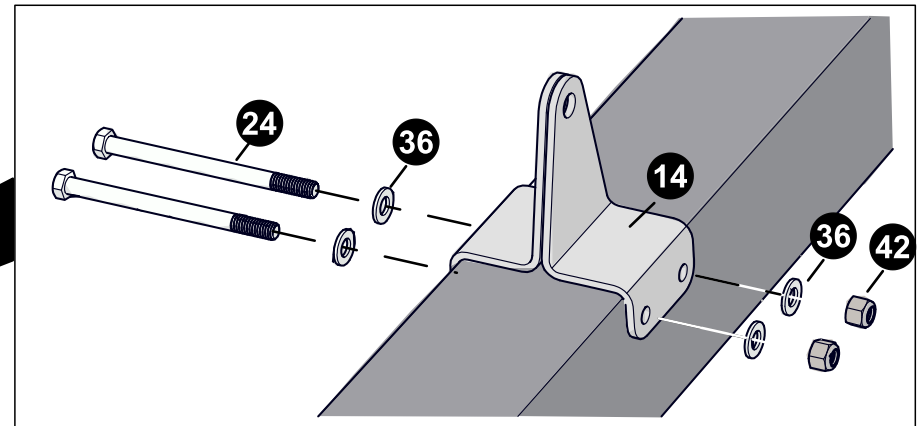
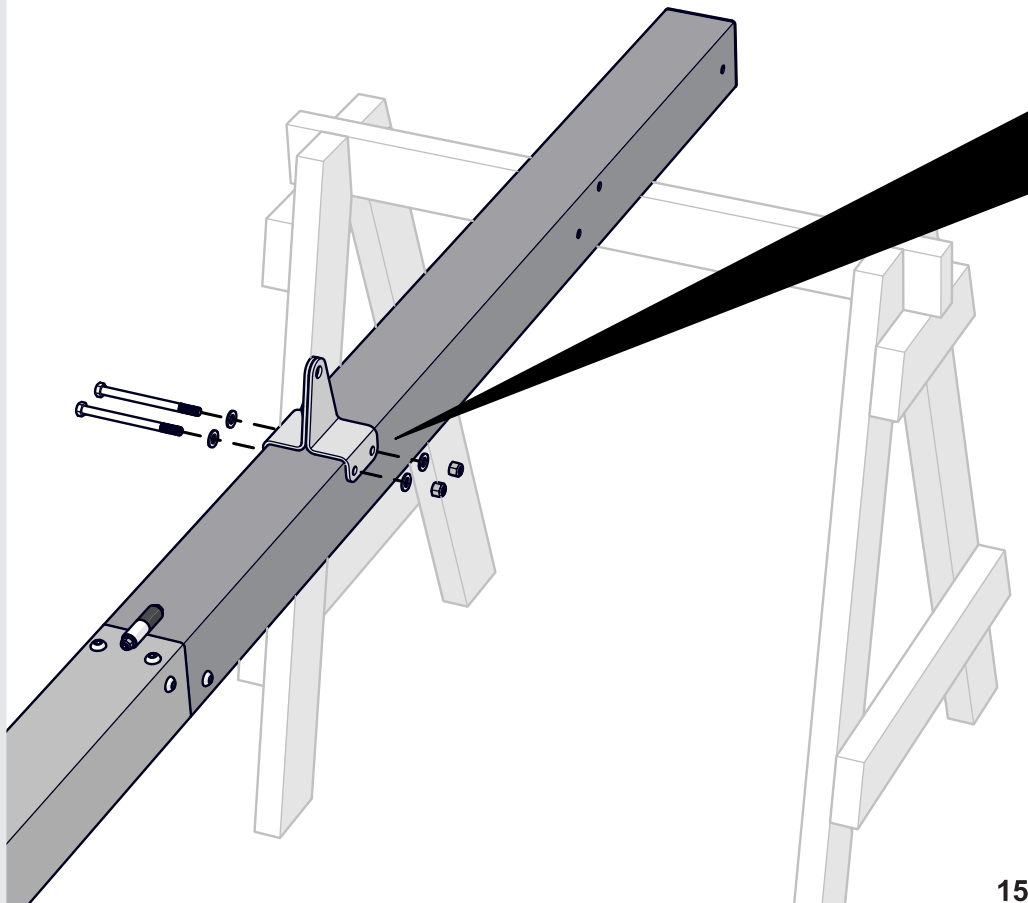

### NOTE

ATTACH POST EARS AS SHOWN. Tighten hardware about 3/4ths of the way. Leave loose enough to attach Actuator on page 18.

## HARDWARE NEEDED (ACTUAL SIZE)



3/8-16 X 7.00 HHCS, ZINC GR 5  
1B-6484-10  
QTY. 1

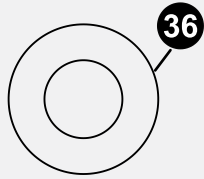

3/8" WASHER  
701-50  
QTY. 2

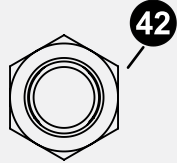

3/8-16 LOCKNUT  
901-28  
QTY. 1

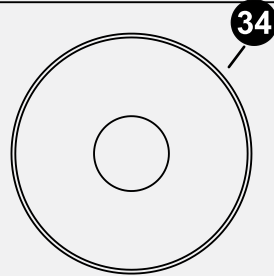

WASHER 0.38 ID X 1.25 OD,  
NYLON  
3M-6883-00  
QTY. 2

## TOOLS NEEDED



### NOTE

IT IS IMPORTANT FOR THE INSTALLER TO UNDERSTAND THE NECESSITY OF THE NYLON WASHERS (#34) PROVIDED. THESE WASHERS ADEQUATELY SPACE PAINTED PARTS AT THE PIVOT POINTS. NEGLECTING THE USE OF THESE WASHERS WILL RESULT IN RUSTED PARTS.

### HELPFUL HINT:

To secure item #34 (3M-6883-00) Nylon Washer in position for assembly use several small strips of tape, drops of hot melt glue or other adhesive. Make sure Nylon Washer is positioned correctly before securing.

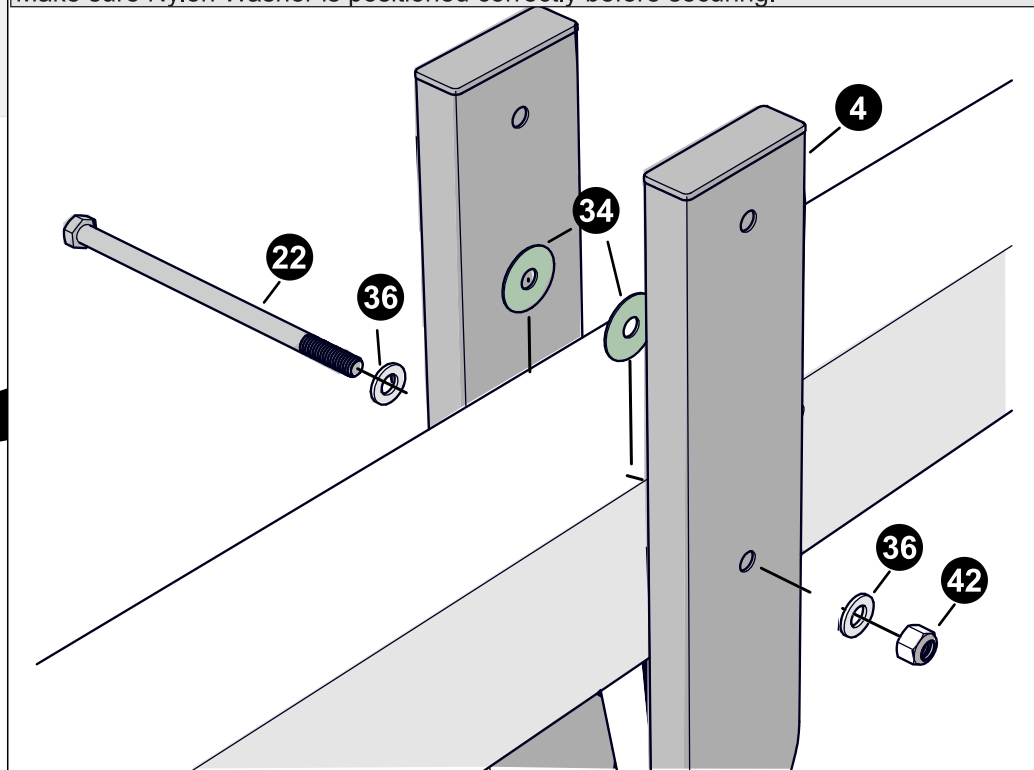
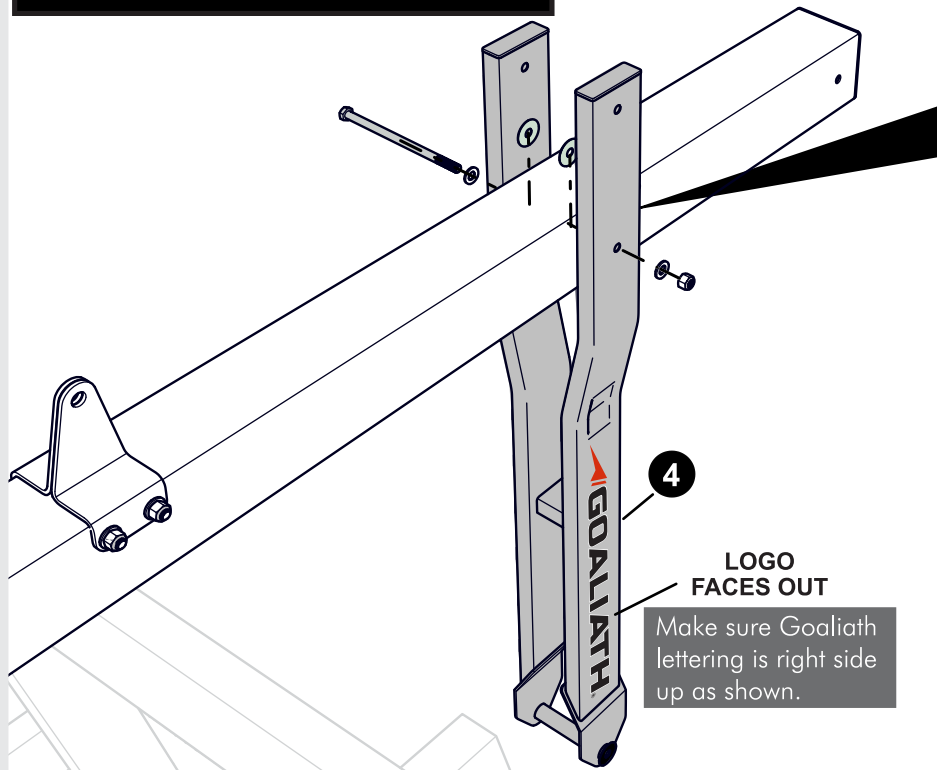

### NOTE

Attach Lower Arm (#4) to the holes that are centered on the pole, the offset holes will be used for a later step (for arm stops). **Tighten hardware but back off half a turn** once you feel the hardware is snug. Make sure Nylon Washers (#34) are installed between the arms and Pole as shown.



**HARDWARE NEEDED**

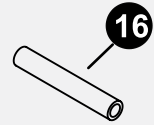

PIVOT TUBE  
8S-6658-00  
QTY. 1

(Packed in hardware kit)

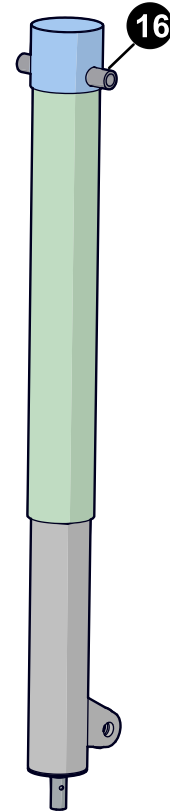
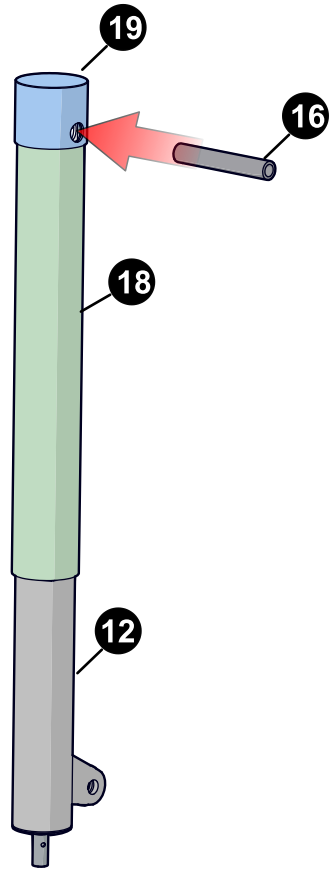

**NOTE**

**PIVOT TUBE (#16) MUST GO THROUGH THE ACTUATOR CAP (#19),  
ACTUATOR SLEEVE (#18) AND THE STEEL ACTUATOR TUBE (#12).**

### HARDWARE NEEDED (ACTUAL SIZE)

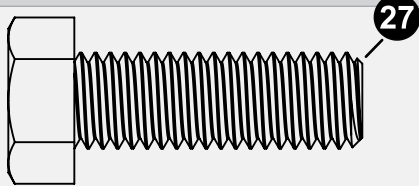

1/2-13 X 1 1/2" HHCS  
1B-6486-10  
QTY. 1

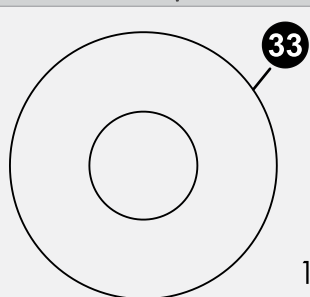

1/2" FLAT WASHER, ZINC  
2B-6093-00  
QTY. 2

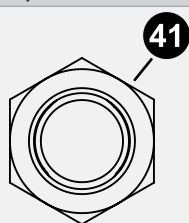

1/2-13 NUT NYLOK, ZINC  
2B-6095-00  
QTY. 1

### TOOLS NEEDED

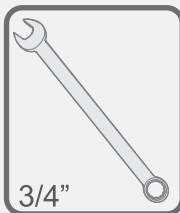

3/4"

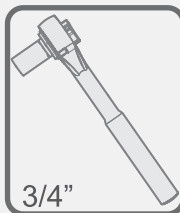

3/4"

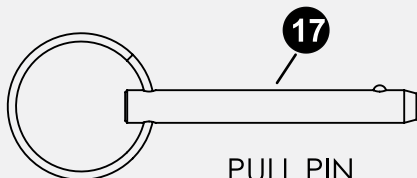

PULL PIN  
7B-6255-00  
QTY. 1

### NOTE

Attach actuator (#12) to post ears as shown, tighten but leave loose enough for actuator to pivot. At this time attach the Actuator handle (#13) with pin (#17).

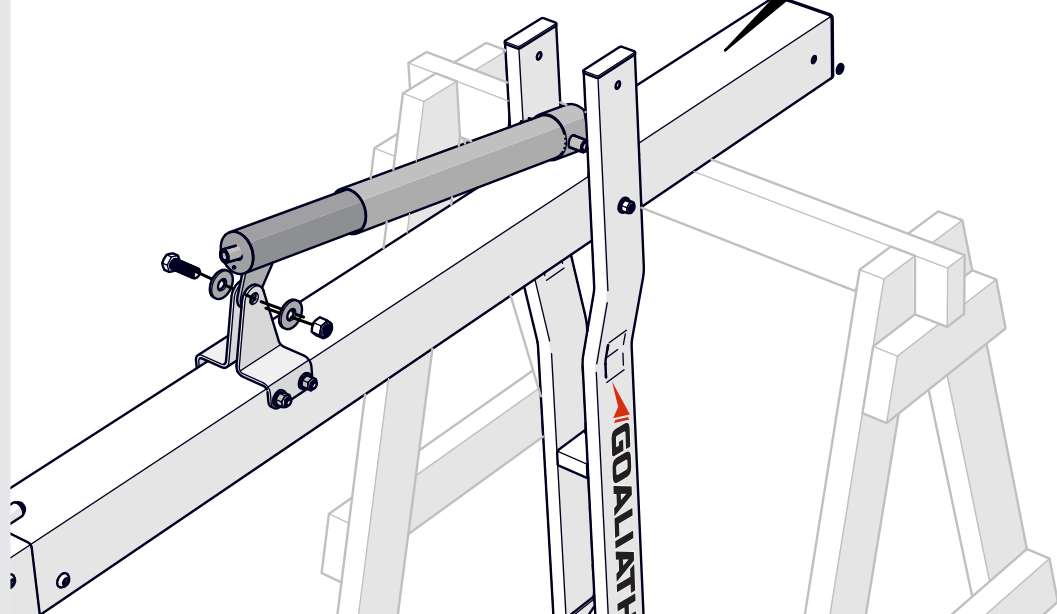
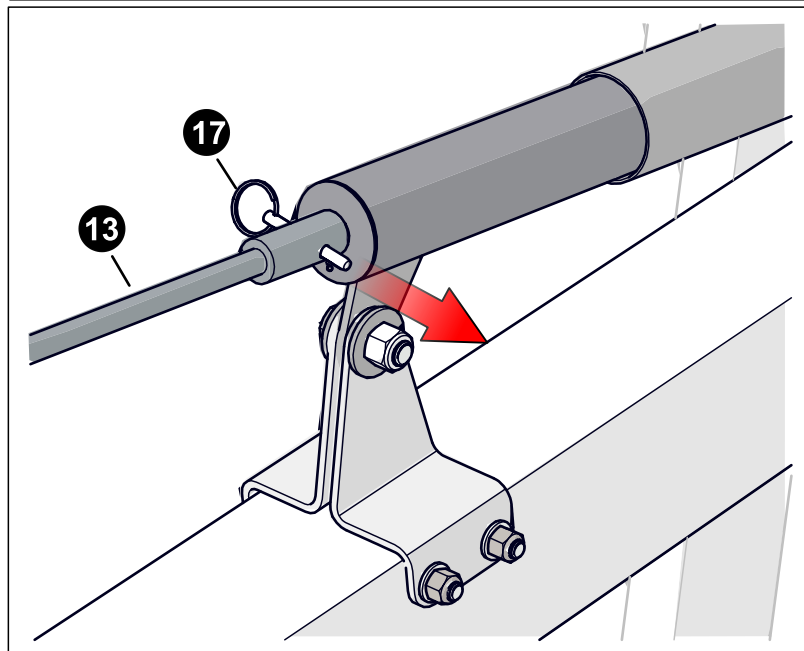
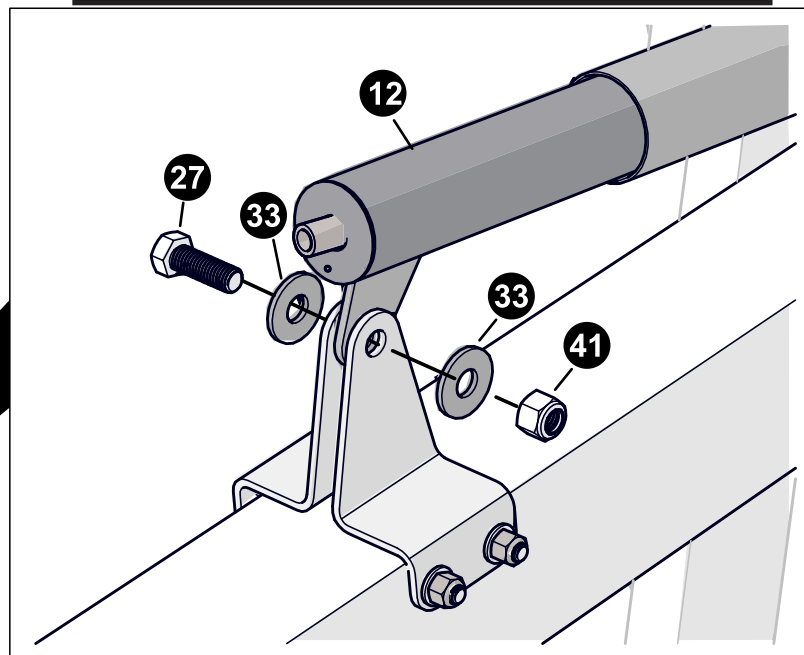

## HARDWARE NEEDED (ACTUAL SIZE)



3/8-16 X 7.00 HHCS, ZINC GR 5  
1B-6484-10  
QTY. 1

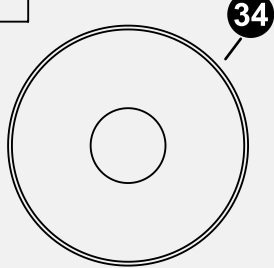

WASHER 0.38 ID X  
1.25 OD NYLON  
3M-6883-00  
QTY. 2

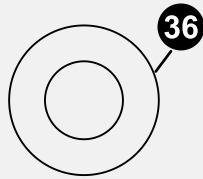

3/8" WASHER  
701-50  
QTY. 2

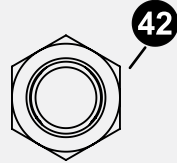

3/8-16 LOCKNUT  
901-28  
QTY. 1

## TOOLS NEEDED



### NOTE

If needed extend the actuator by turning the handle clockwise until the actuator Pivot tube hole lines up with the holes on lower board arm.

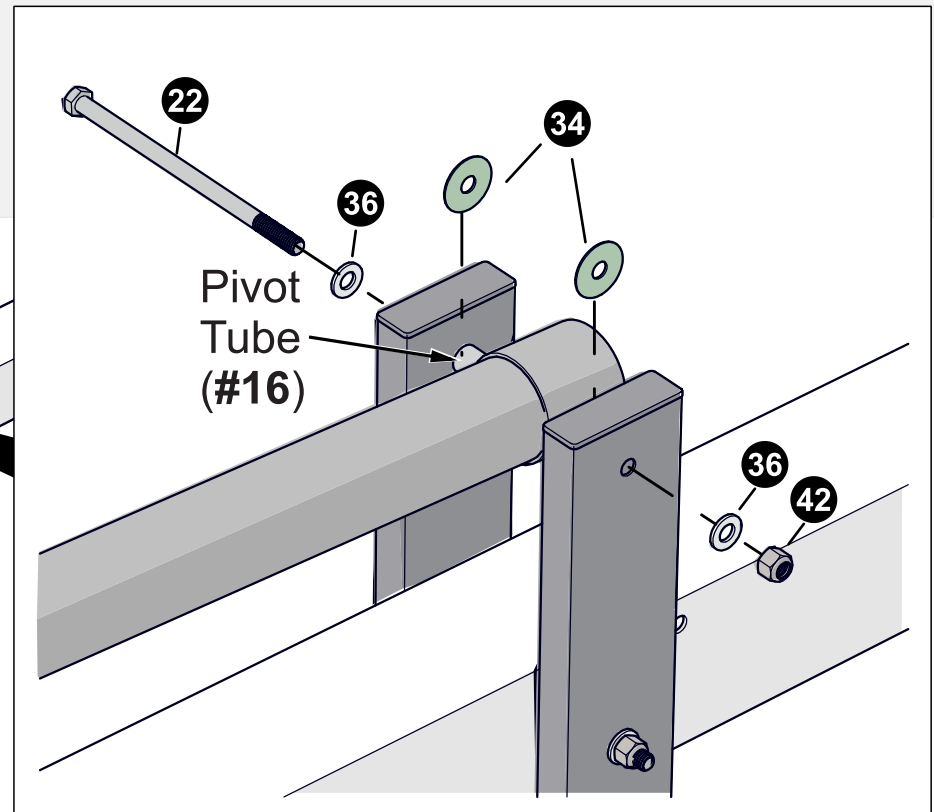

### NOTE

Pivot actuator up and attach to the lower board arm assembly. **Tighten hardware but back off half a turn** once you feel the hardware is snug. Make sure Nylon Washers (#34) are installed between the arms and Actuator pivot tube as shown.

**TOOLS NEEDED**

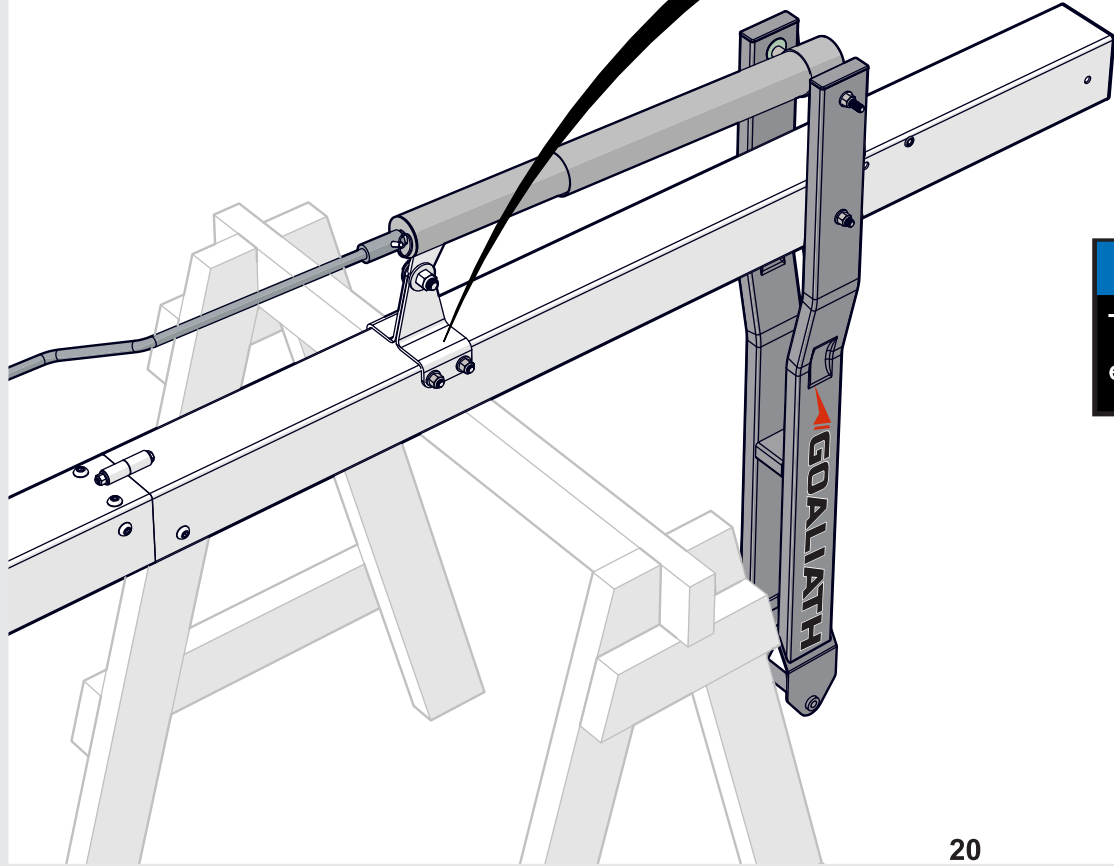
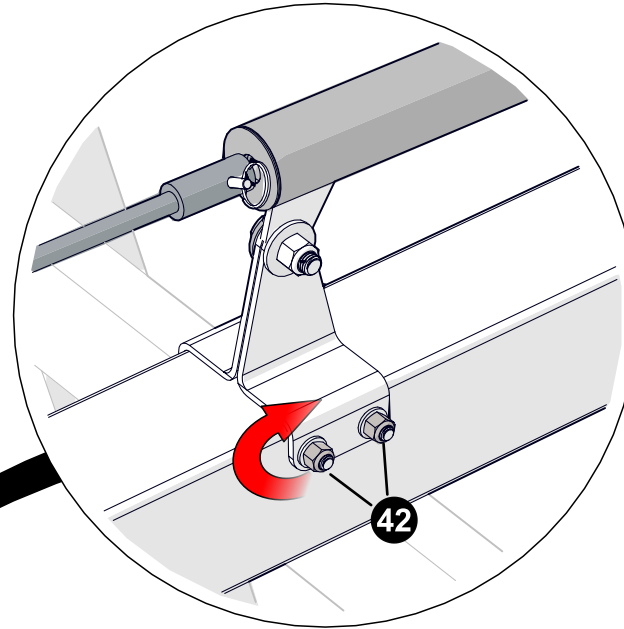

**NOTE**  
Tighten Lock Nuts (#42) that hold the post ears until tight.

## HARDWARE NEEDED (ACTUAL SIZE)



3/8 - 16 X 7.5" HHCS, Grade 5  
1B-6483-10  
QTY. 1

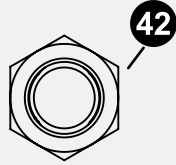

3/8-16 LOCKNUT  
901-28  
QTY. 1

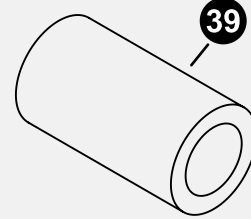

STOP SPACER  
8S-6657-00  
QTY. 2

## TOOLS NEEDED

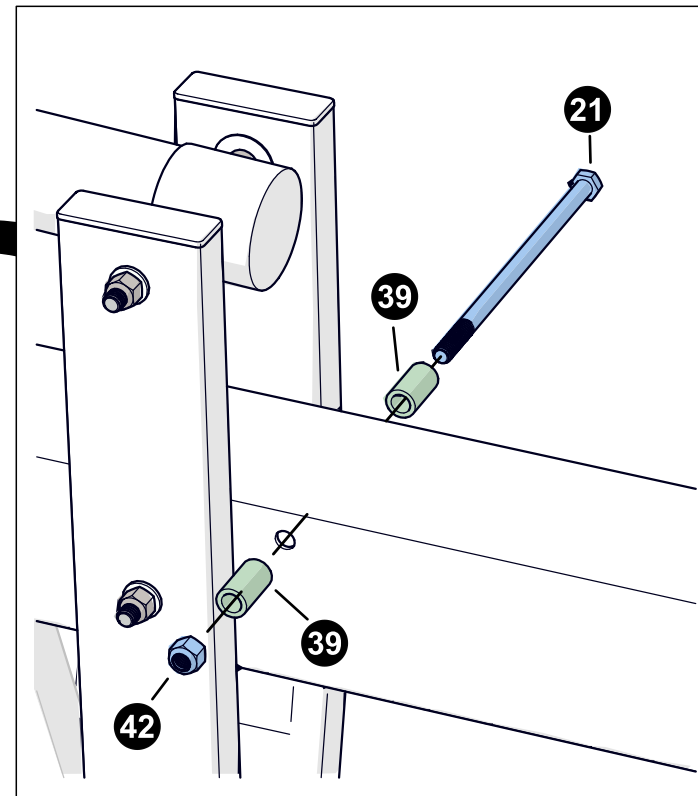
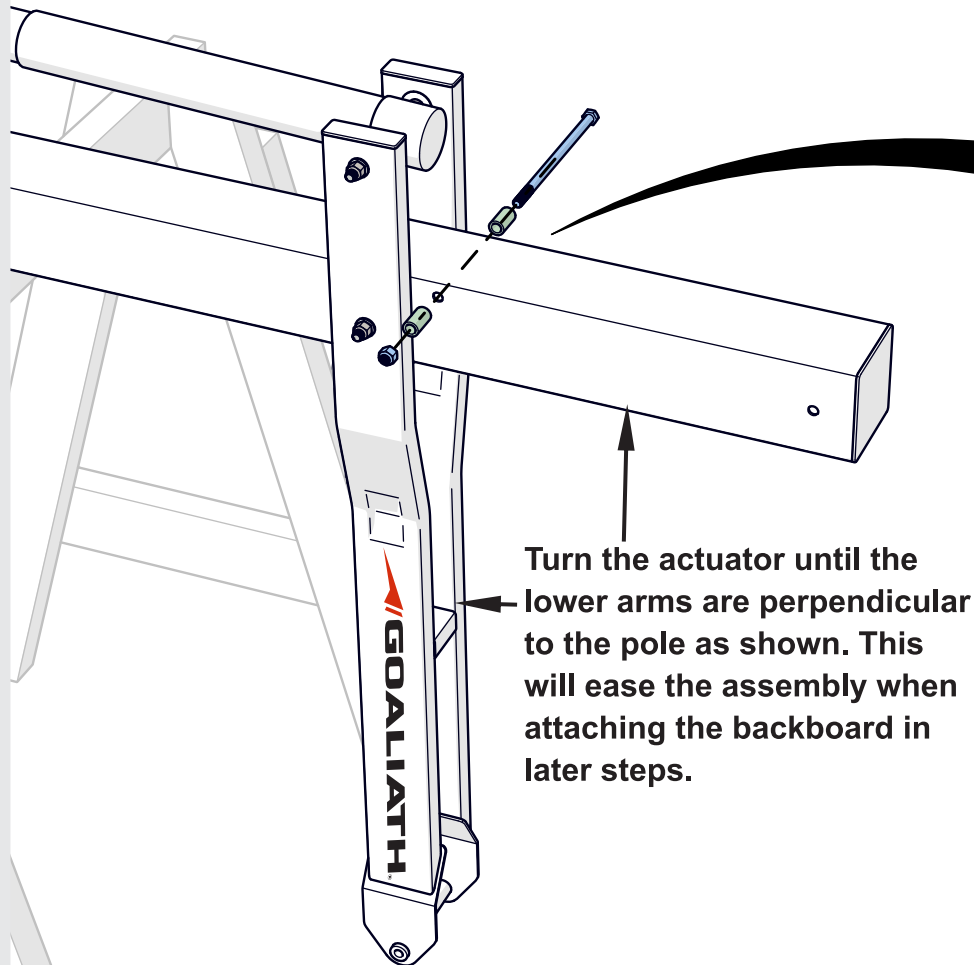

### NOTE

Attach stop spacers in the hole next to the upper arm as shown. Tighten until tight.

**HARDWARE NEEDED (ACTUAL SIZE)**

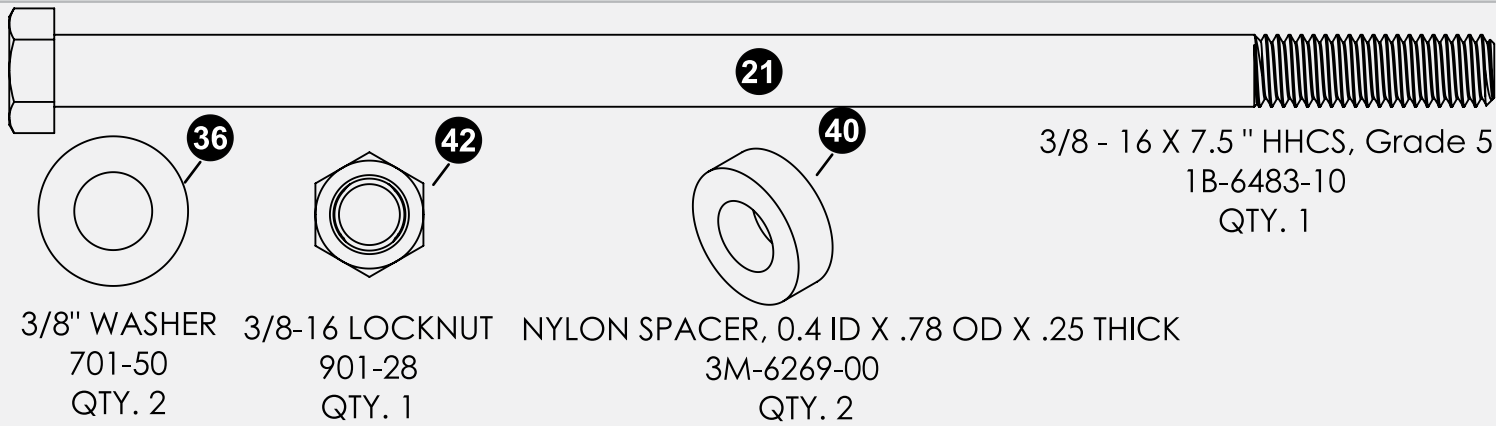

**TOOLS NEEDED**

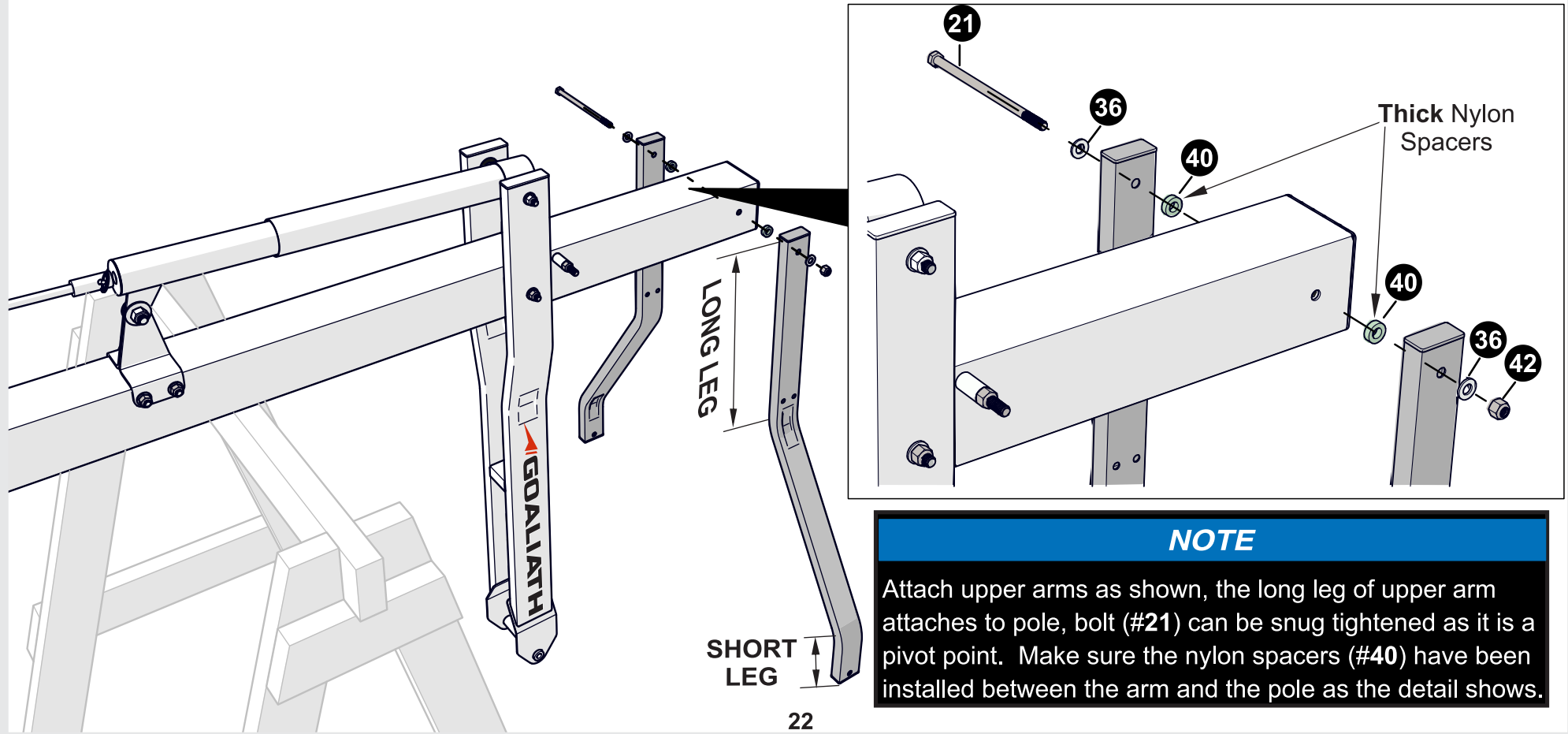
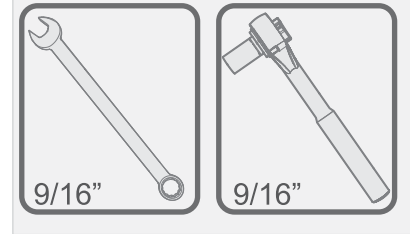

HARDWARE NEEDED (ACTUAL SIZE)

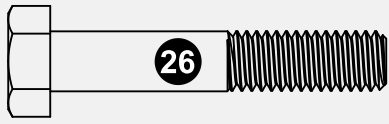

5/16-18 X 1.75 HHCS, ZINC  
1B-7190-00  
QTY. 4

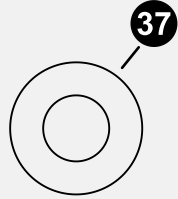

5/16" WASHER  
2B-6024-00  
QTY. 8

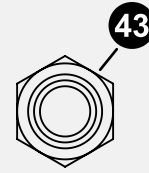

5/16-18 NUT NYLOK ZINC  
2B-6009-02  
QTY. 4

TOOLS NEEDED

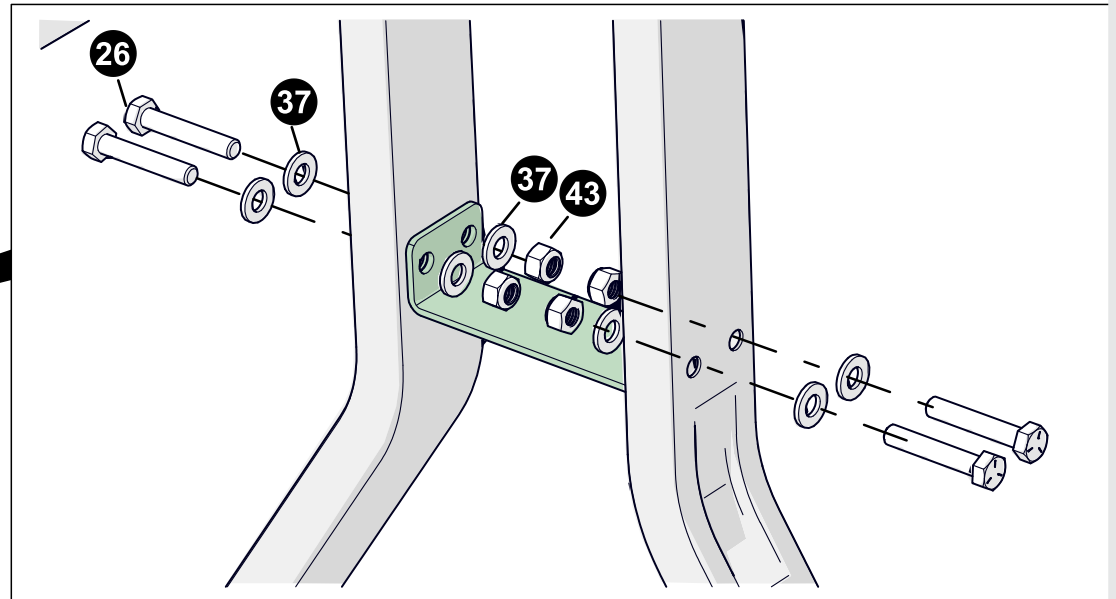
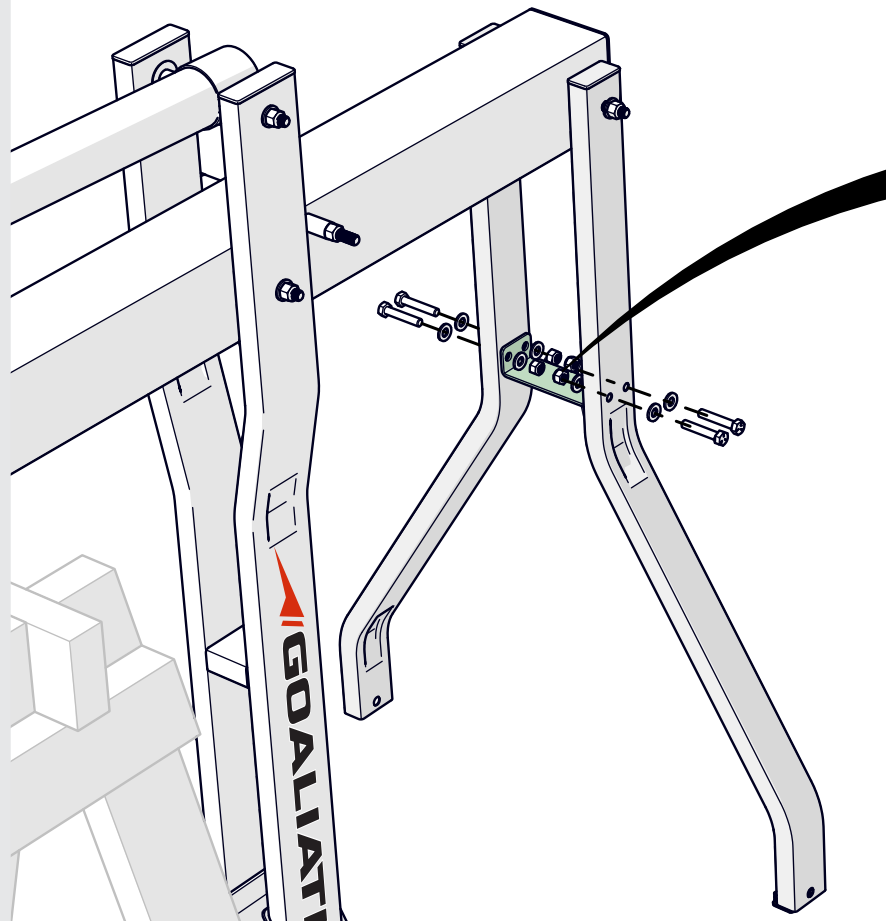
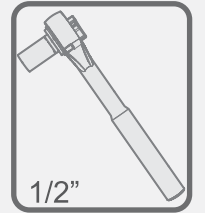
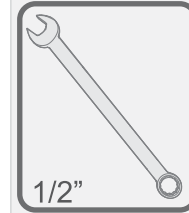

**NOTE**

Attach Board arm brace as shown but hand tighten hardware only. This will make it easier when attaching the Backboard. You will tighten this after the backboard is installed.

**! CAUTION !**

**PLACING THE POST ON THE ANCHOR SYSTEM REQUIRES AT LEAST THREE CAPABLE ADULTS. POLE WILL WANT TO LEAN WHILE ATTEMPTING TO STAND IT UP ON ANCHOR BOLTS.**

1. With one person holding the lower pole have a second person remove one saw horse, then carefully lower the pole on the ground.
2. With the help of another capable adult pivot the assembly onto the anchor bolts. Have a third person ready with the washers and nuts and the corresponding wrenches, read and understand the next page before pivoting this assembly up.

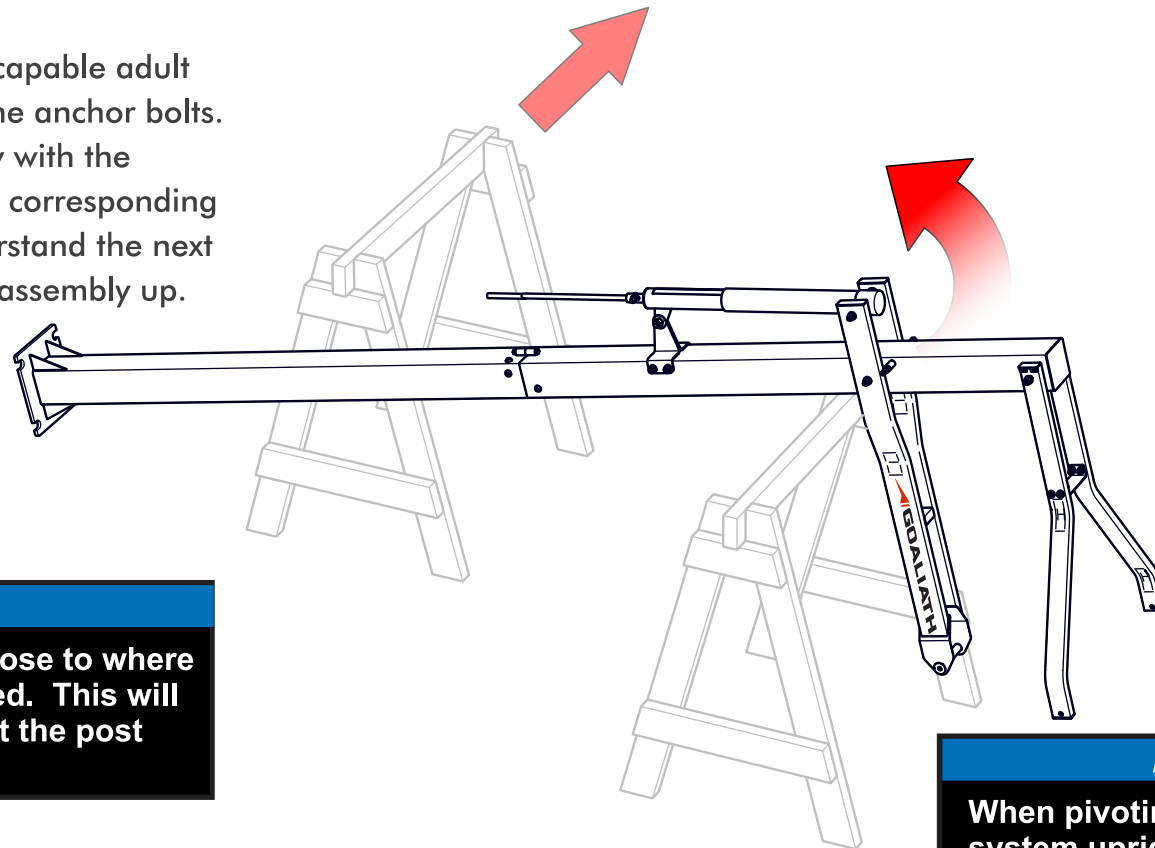
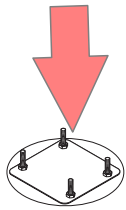

**NOTE**

**Place the end of the pole close to where the anchor system is located. This will make it easier when you set the post assembly upright.**

**NOTE**

**When pivoting the basketball system upright the top arms will pivot down, make sure to keep those under control so they rest safely on the lower board arms.**



## HARDWARE NEEDED (ACTUAL SIZE)



5/8"-11 HEX NUT  
2B-6097-02  
**(QTY. 4)**

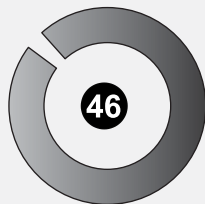

5/8" SPLIT LOCK  
WASHER  
2B-6099-02  
**(QTY. 4)**



5/8" FLAT WASHER  
2B-6098-03  
**(QTY. 8)**

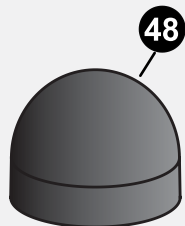

5/8" THREAD  
PROTECTOR  
PLASTIC CAP  
3M-9040-00  
**(QTY. 4)**

**\*Hardware located in Anchor kit box**

**3.** Lift post onto anchor system and secure with hardware as shown. Tighten Fasteners finger tight, leave loose enough to level pole. Place a level on pole and adjust bottom nuts **45** until pole is level (left to right and front to back). Tighten top four hex nuts **45** tight.

**4.** Push on Thread Protector Cap **48** until it is securely in place. Cap may be tight, push hard but **DO NOT** hit with a hammer! See **Detail A**.

## TOOLS NEEDED

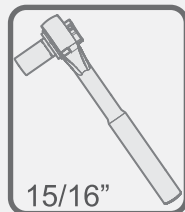

15/16"

OR

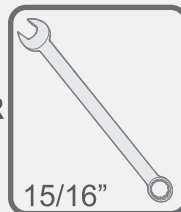

15/16"

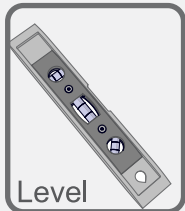

Level



**PLACING THE POST ON THE ANCHOR SYSTEM REQUIRES AT LEAST TWO CAPABLE ADULTS. POLE WILL WANT TO LEAN WHILE ATTEMPTING TO STAND IT UP ON ANCHOR BOLTS.**

## NOTE

**DO NOT REMOVE BOTTOM NUTS #45 THAT YOU INSTALLED IN STEP 2 (PAGE 3).**

Let concrete cure for a **MINIMUM** of 72 hours before installing pole.

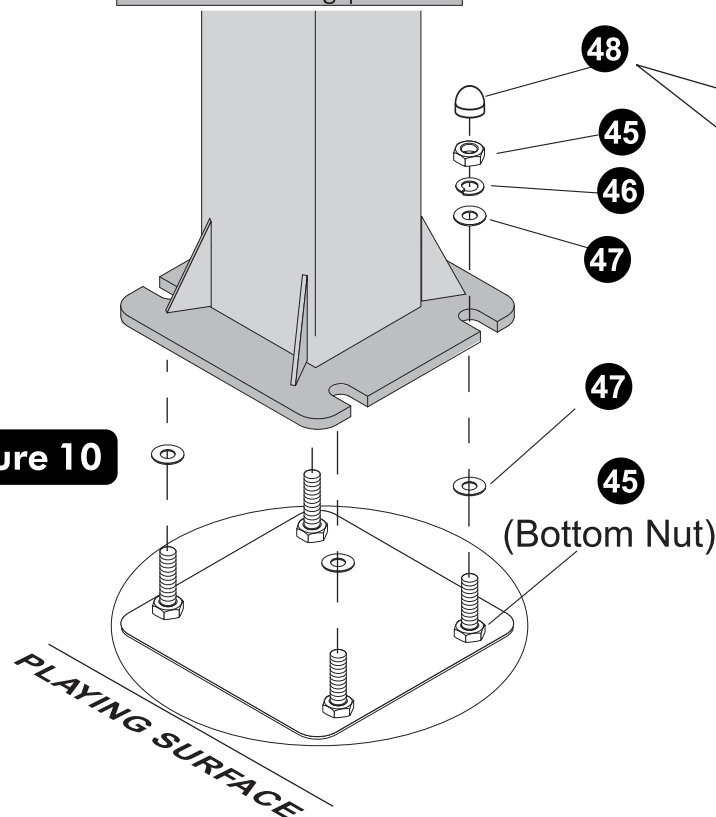

**Figure 10**

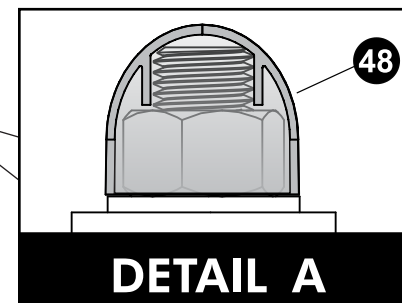

## DETAIL A

### NOTE:

If basketball system needs to be moved, **do not** try to salvage caps. Caps (#48) will be tight, please remove with pliers and discard. New caps will come in new anchor system.

### NOTE:

If (#48) caps are missing for any reason please call customer service.

### NOTE:

Bottom nuts #45 can be used for leveling system.

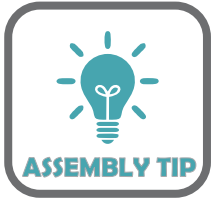

Before proceeding to the next step have the hardware and tools ready along at least 3 other capable people, read the next page completely and understand it before beginning the next step.

### HARDWARE NEEDED (ACTUAL SIZE)



3/8-16 X 6.25" HHCS, GRADE 5  
1B-7188-00  
QTY. 1

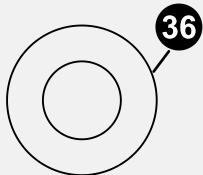

3/8" WASHER  
701-50  
QTY. 2



3/8-16 LOCKNUT  
901-28  
QTY. 1

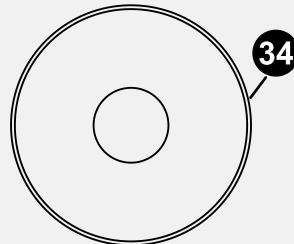

NYLON WASHER,  
0.38 ID X 1.25 OD  
3M-6883-00  
QTY. 2

### TOOLS NEEDED



**! CAUTION !**

ATTACHING BACKBOARD TO BOARD ARMS REQUIRES AT LEAST FOUR CAPABLE ADULTS.

**! CAUTION !**

HANDLE BACKBOARD WITH CARE, IT IS A GLASS PRODUCT ALWAYS WEAR SAFETY GLASSES AND GLOVES WHEN HANDLING GLASS.

5. With at least **four** capable adults, raise the backboard assembly up and have the **fifth** person attach lower board arm **2** to **rim support** as shown in **Detail B**.

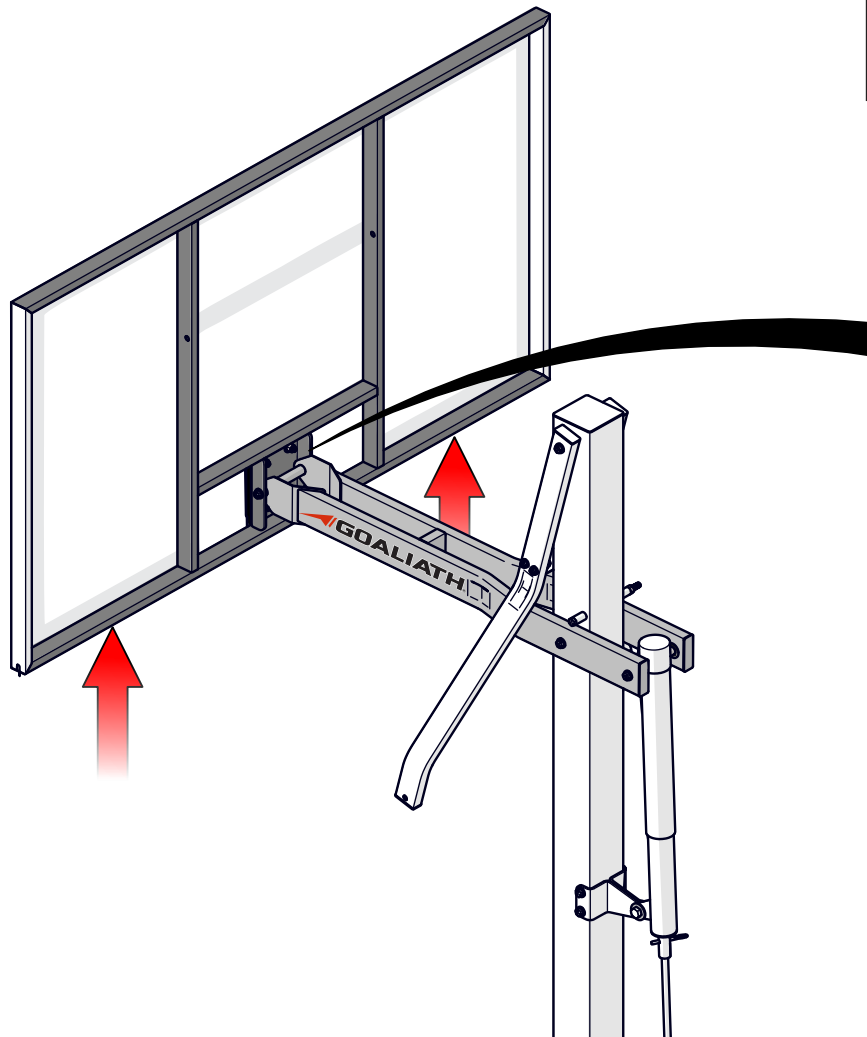

**NOTE**

DO NOT OVER TIGHTEN THESE BOLTS. THIS IS A PIVOT POINT, SNUG IS TIGHT ENOUGH.

**HELPFUL HINT:**

To secure item #34 (3M-6883-00) Nylon Washer in position for assembly use several small strips of tape, drops of hot melt glue or other adhesive. Make sure Nylon Washer is positioned correctly before securing.

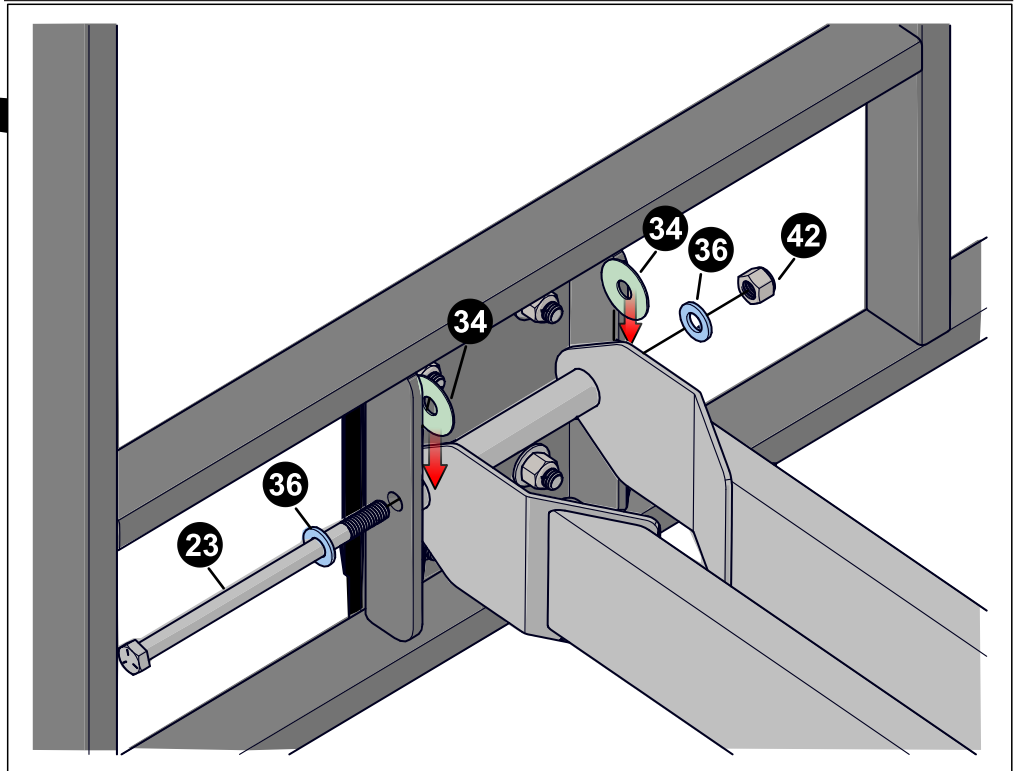

## HARDWARE NEEDED (ACTUAL SIZE)

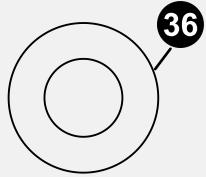

3/8" WASHER  
701-50  
QTY. 4

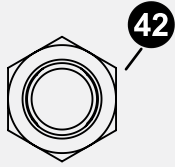

3/8-16 LOCKNUT  
901-28  
QTY. 2

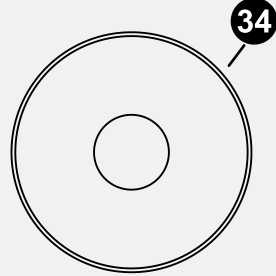

NYLON WASHER,  
0.38 ID X 1.25 OD  
3M-6883-00  
QTY. 2



3/8-16 X 2 3/4" HHCS  
1B-6195-00  
QTY. 2

## TOOLS NEEDED

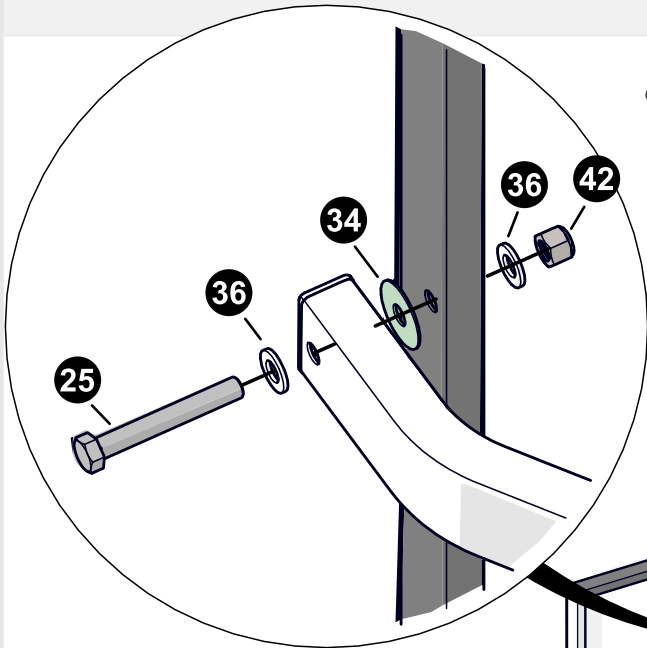

6. Pivot upper arms up and attach to the outside of **Backboard frame** as shown. Make sure you have a Nylon Washer (#34) between the arms and the backboard frame. Tighten this hardware until snug tight but do not collapse tubes.

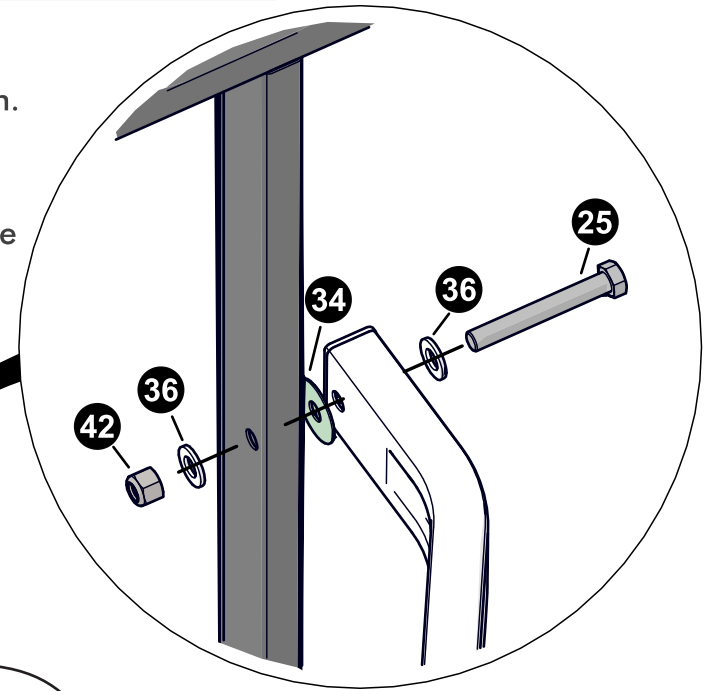

### NOTE

DO NOT OVER TIGHTEN THESE BOLTS. THIS IS A PIVOT POINT, SNUG IS TIGHT ENOUGH.

### NOTE

AFTER THE BACKBOARD IS ATTACHED SNUG TIGHTEN THE BOARD ARM BRACE HARDWARE, FROM PAGE 23, BUT DO NOT COLLAPSE THE TUBES.

**HARDWARE NEEDED (ACTUAL SIZE)**

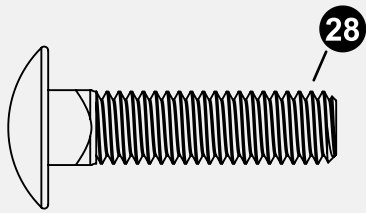

3/8-16 X 1.50 CB, ZINC  
1B-7187-00  
QTY. 4

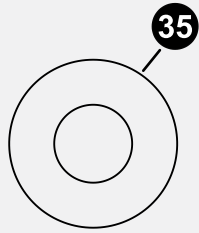

3/8 FLAT WASHER  
2B-6114-00  
QTY. 4

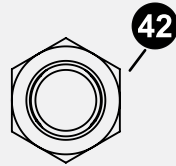

3/8-16 LOCKNUT  
901-28  
QTY. 4

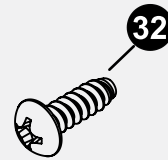

#8 X 1/2" SCREW  
1B-6788-00  
QTY. 4

**TOOLS NEEDED**

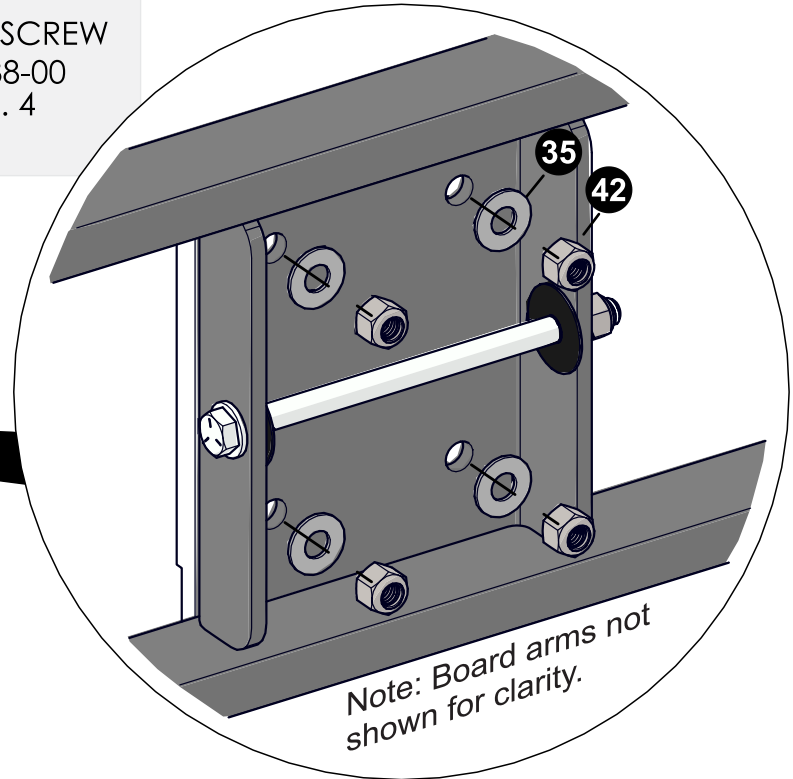
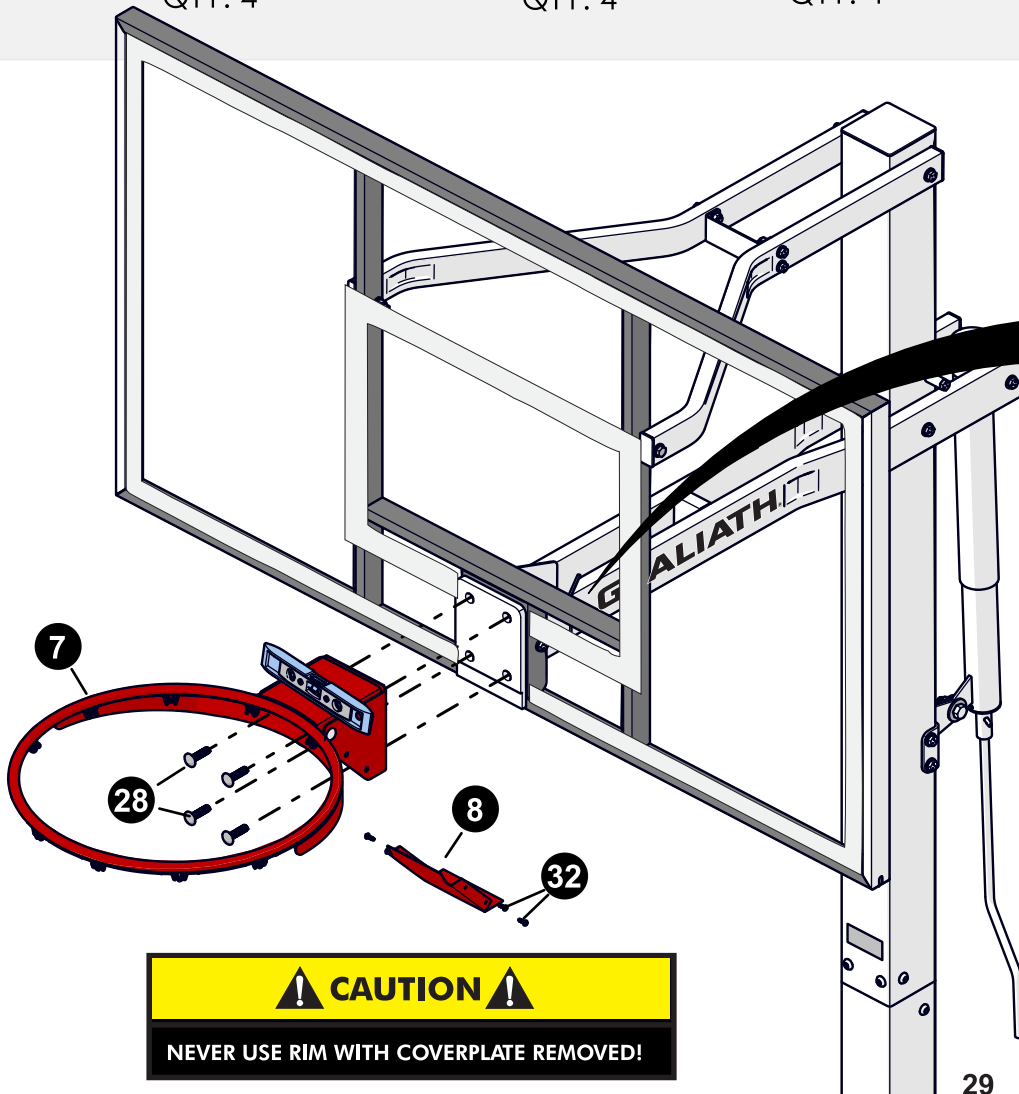

**⚠ CAUTION ⚠**  
NEVER USE RIM WITH COVERPLATE REMOVED!

**NOTE**  
TAKE PROTECTIVE COATING OFF THE BACKBOARD BEFORE ATTACHING THE RIM. LEVEL RIM AND FULLY TIGHTEN THE HARDWARE. MAKE SURE TO INSTALL RIM COVER PLATE WITH (#32) SCREWS.

7. Check all nuts and bolts and make sure everything is tightened properly. **DO NOT over tighten** pivot points, snug is tight enough.
8. Use the Backboard Pads (#44) and (#45) as a template and mark the hole locations on the backboard frame. See **Detail B**.

**Note: Screws (#31), used in step 10, are Self Drilling screws and can be installed without drilling pilot holes. However, it will be easier to install screws if you drill 9/64" pilot holes. WEAR SAFETY GLASSES if drilling holes.**

9. Drill 9/64" pilot holes into steel backboard frame. See **Detail A**. Do not drill through both sides of backboard tube frame.

**Note: Cordless drill recommended for screw installation. Do not over tighten screws causing screws to strip.**

**Note: To install screws, it will be easier if you use a cordless drill with 5/16" socket (instead of Phillips head).**

10. Secure Backboard Pads (#10) and (#11), as shown, using screws (#31). Note: Tighten screws tight but, **do not over tighten**.

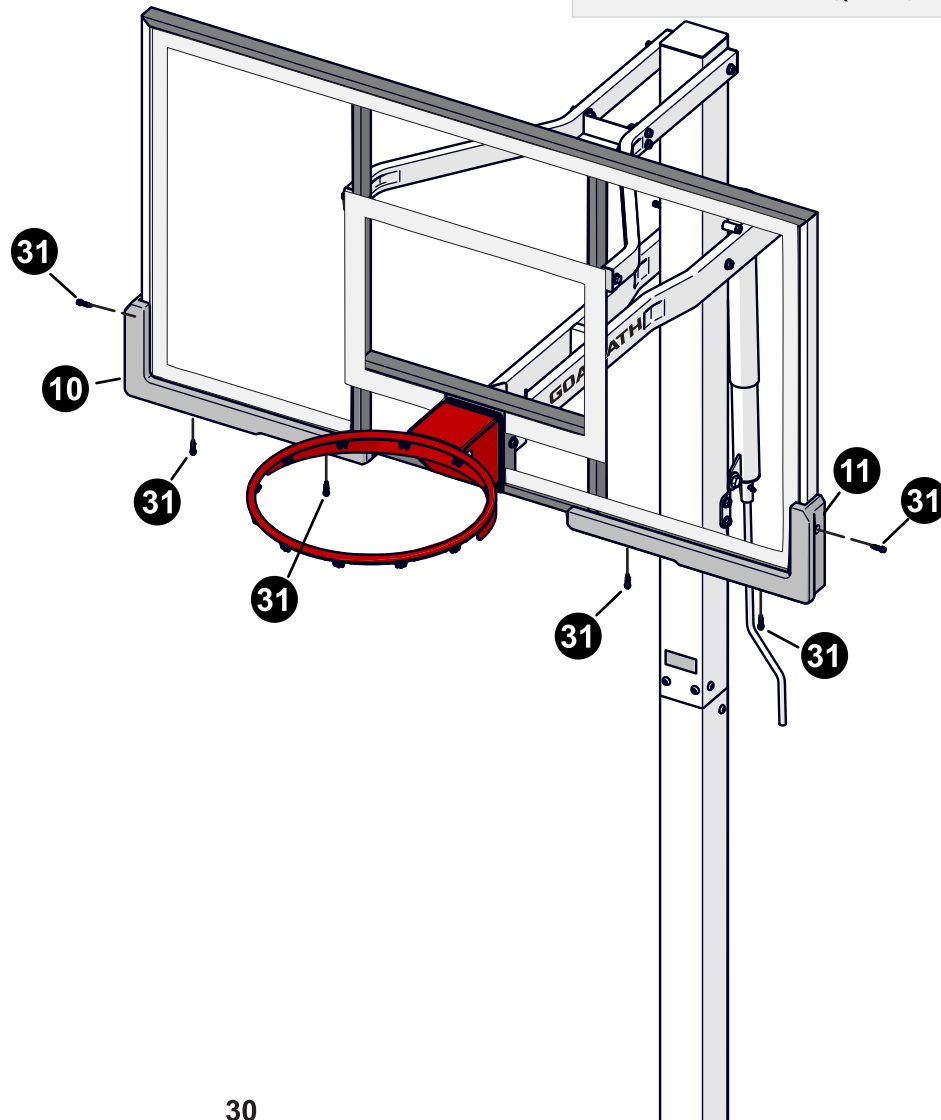
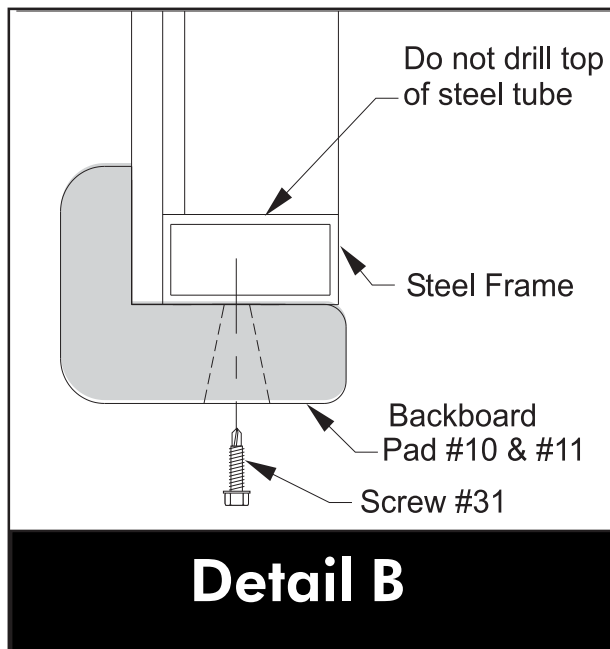
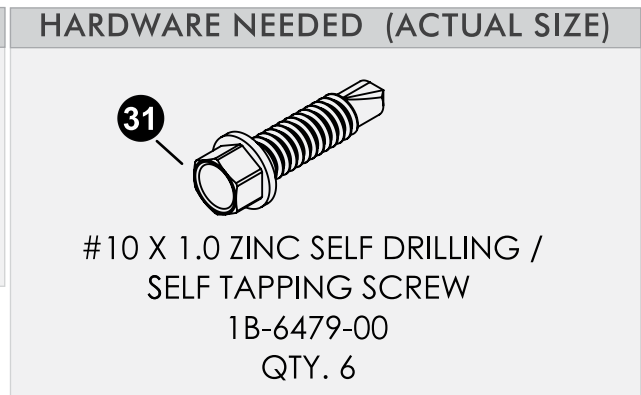
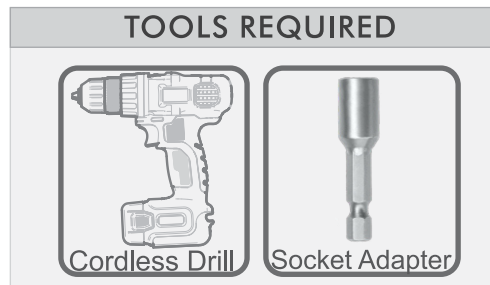

**NOTE**

Attach net as shown in  
Detail C.

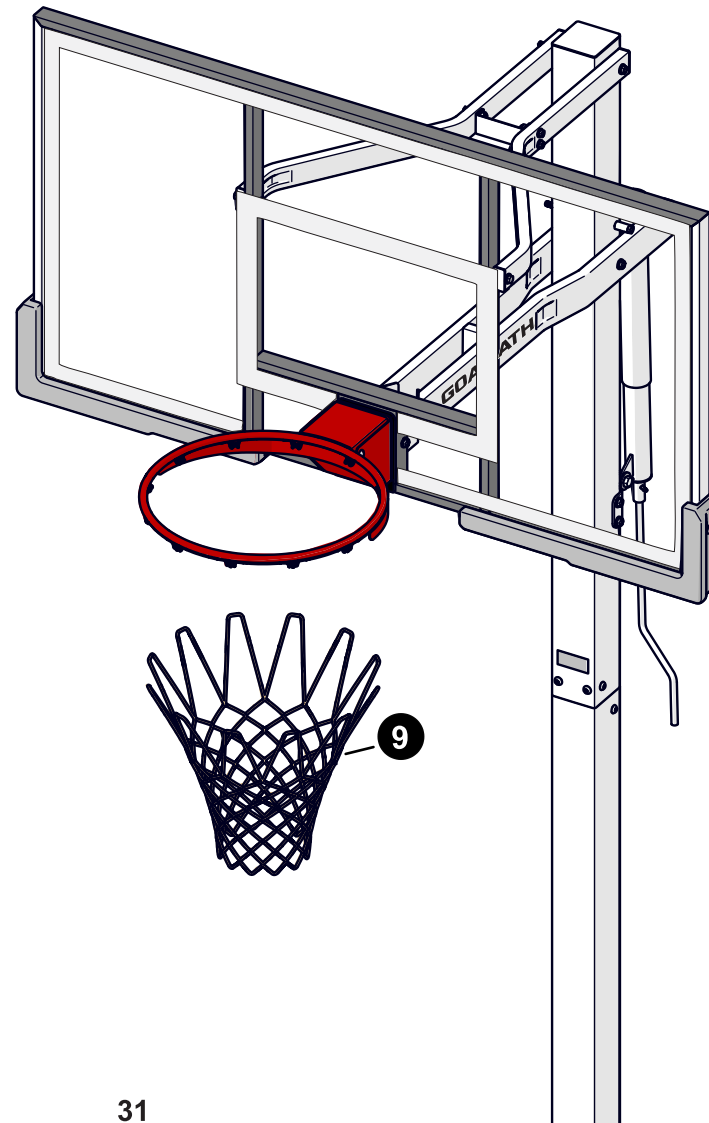
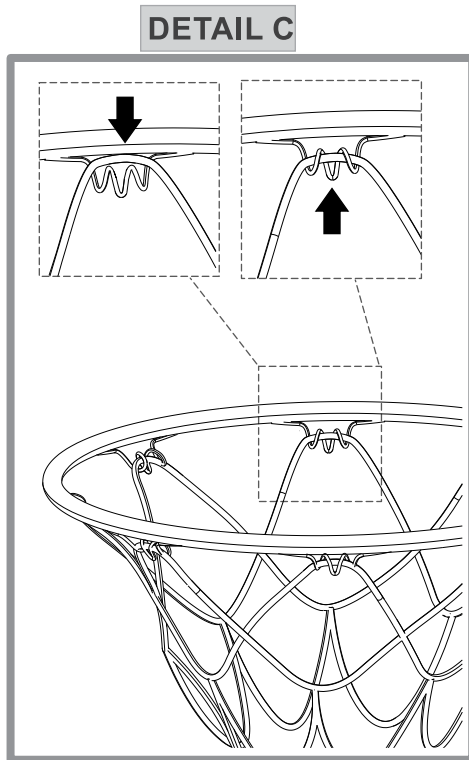

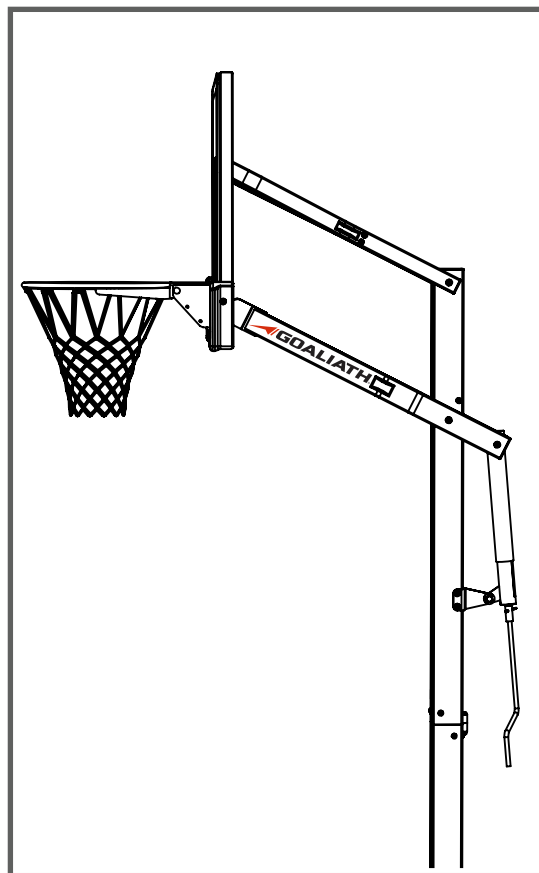
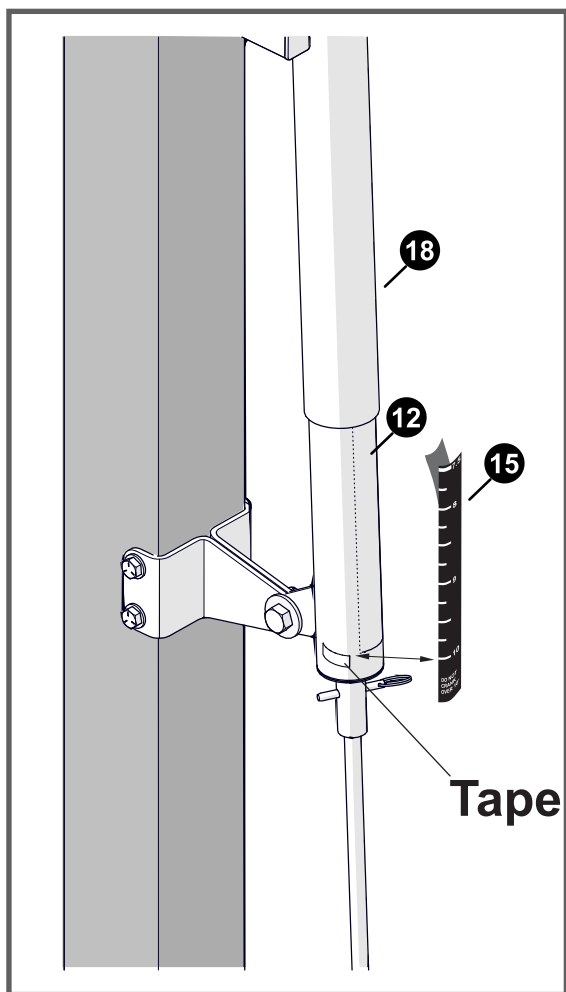

SET AT 10 FEET HIGH

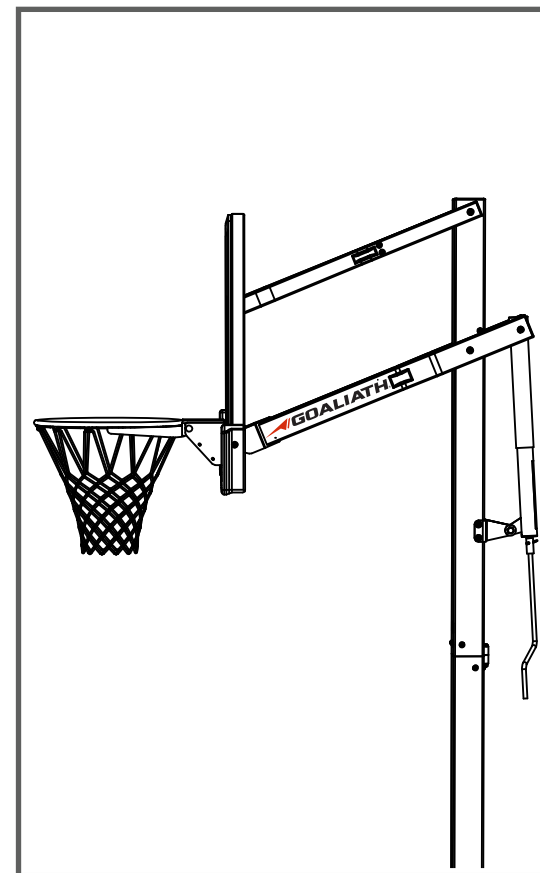

LOWER ALL THE WAY DOWN

Raise Backboard to 10 FT. regulation playing height. Measure from top of rim straight down to the playing surface.

Using tape - mark the side of the steel actuator (#12) just under the plastic actuator sleeve (#18) at this 10 ft rim height. See **Figure 1**.

Lower backboard all the way down. Do not force actuator once backboard is in it's lowest position. See **Figure 2**.

**Do not** remove adhesive backing from height decal (#15) yet. Carefully place height decal on backside of steel actuator and line up the 10 ft mark on the tape with the 10 ft mark on the height decal. Decal should fit correctly onto the backside of the steel actuator. ( If not, simply trim to fit the top of the actuator decal).



12. Secure Post Pad (#53) to front of pole by wrapping straps around pole and sticking to velcro on opposite side of Pad. Post Pad should cover Post Screws but remain below Warning Label on the front of the Pole. Make sure to reposition Pole Pad if sliding occurs.

**NOTE: Do not cover the Warning Label on the front of the pole with the Pole Pad.**

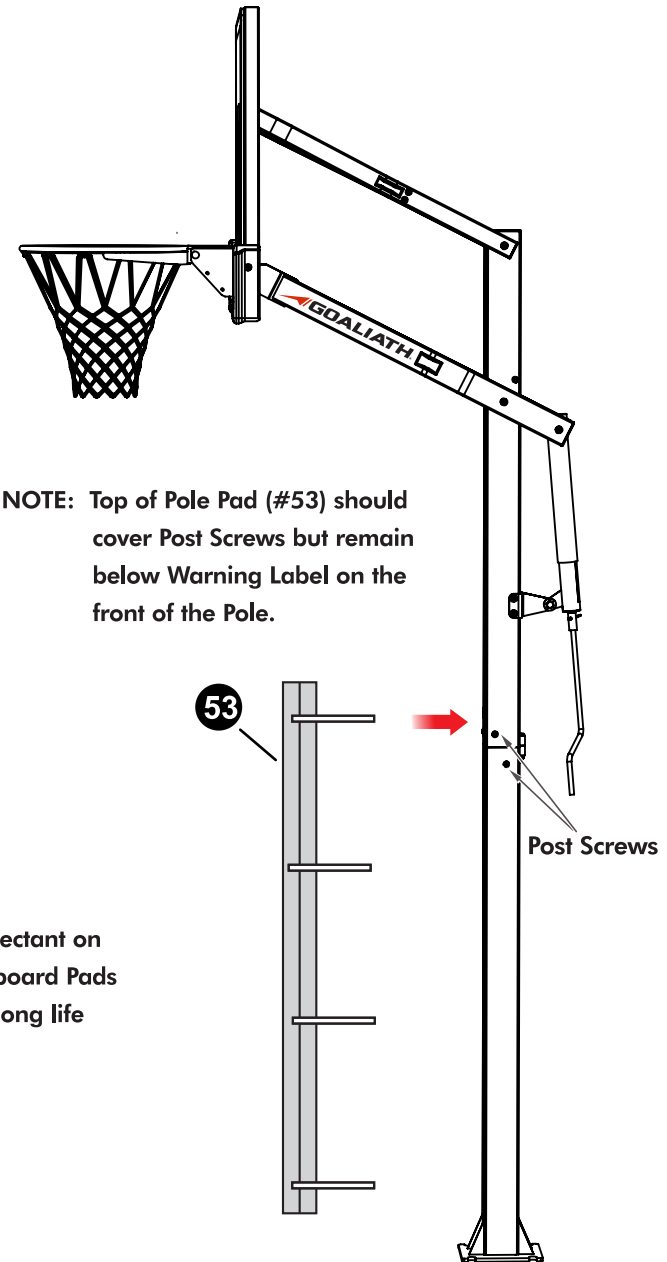

**Helpful hint:** Periodically, use a vinyl protectant on both the Pole Pad and Backboard Pads to insure the best look and long life

## LIMITED 5 YEAR WARRANTY

This consumer warranty extends to the original consumer purchase of any Escalade® Sports Product (hereinafter referred to as the "Product").

**WARRANTY COVERAGE:** Escalade® Sports warrants to the original Consumer Purchaser that any Product of its manufacture is free from defects in material and workmanship. THIS WARRANTY IS VOID IF THE PRODUCT HAS BEEN DAMAGED BY ACCIDENT, UNREASONABLE USE, NEGLIGENCE, IMPROPER SERVICE, FAILURE TO FOLLOW INSTRUCTIONS PROVIDED WITH THE PRODUCT OR OTHER CAUSES NOT ARISING OUT OF DEFECTS IN MATERIAL OR WORKMANSHIP.

Subject to proper installation and normal Residential use, Escalade® Sports warrants, subject to the limitations below, to the original retail purchaser all structural components of the Goaliath® System to be free of defects in material and workmanship for a period of five (5) years from the original purchase.

Merchandise must be shipped prepaid with a copy of proof of purchase to Escalade® Sports factory for examination to determine if the basketball system needs to be repaired or replaced. Any labor costs, travel expenses and any other changes involved in the removal, installation or replacement of the defective/repared parts from/to your Goaliath® System will be the purchaser's responsibility. Shipping charges for replaced or warranted merchandise sent back to the customer from Escalade® Sports factory must be prepaid by the customer in advance. If not, the replacement shipment will be sent out collect.

Escalade® Sports reserves the right to examine photographs or physical evidence of merchandise claimed to be defective, and to recover said merchandise, prior to authorization of warranty claims. A "Returned Goods Authorization" number may be required, please call for details prior to the return of any photographs or merchandise.

This limited 5 year warranty is expressly in lieu of all warranties, expressed or implied, including warranties of merchantability or fitness for use. Escalade® Sports does not assume or authorize any person or representative to assume for us, any other liability in connection with the sale of our products.

The remedy of repair or replacement stated above is Escalade® Sports exclusive remedy. Escalade® Sports will not be liable for any other damages or expenses which may incur, including but not limited to incidental or consequential damages. Escalade® Sports assumes no other obligations or liability on the part of the purchaser, and Escalade® Sports neither assumes nor authorizes any other person to assume for it any other liability in connection with the goods sold.

This warranty shall not apply in any manner to parts or accessories not manufactured by Escalade® Sports.

### NOT COVERED BY THIS WARRANTY

- Merchandise not intended to be in places of public assembly, such as, but not limited to, schools, parks, public or private recreational facilities.
- Any merchandise subjected to Non-residential abuse, negligence, improper installation, vandalism, acts of God, alteration of product, or any other events beyond the control of Escalade® Sports.
- Paint or rusted parts. If rust should appear, remove loose paint, sand lightly, primer and paint with exterior flat matte finish enamel paint.
- HANGING ON RIM WILL VOID THE WARRANTY: Rims are not warranted for any defects other than workmanship. Torn back plates, damaged springs, bent rings, damaged eyebolts, and torn or distorted rim supports result from hanging on the rim and are not warranted.
- Shipping charges both ways. Note: Any merchandise shipped to Escalade® Sports collect will be refused.
- Dealer service charges, labor charges and travel expenses associated with replacement of repair of warranty item.

**WARRANTY DISCLAIMERS:** ANY IMPLIED WARRANTIES ARISING OUT OF THIS SALE, INCLUDING BUT NOT LIMITED TO THE IMPLIED WARRANTIES OF MERCHANTABILITY AND FITNESS FOR A PARTICULAR PURPOSE, ARE LIMITED IN DURATION. ESCALADE® SPORTS SHALL NOT BE LIABLE FOR LOSS OF USE OF THE PRODUCT OR OTHER CONSEQUENTIAL OR INCIDENTAL COSTS. EXPENSES OR DAMAGES INCURRED BY THE CONSUMER OF ANY OTHER USE.

Some states do not allow the exclusion or limitation of implied warranties or consequential or incidental damages, so the above limitations or exclusions may not apply to you.

LEGAL REMEDIES: This warranty gives you specific legal rights, and you may also have other rights which may vary from state to state.

### WARRANTY GUIDELINES IS REQUIRED FOR ALL WARRANTY CLAIMS

1. Proof of Purchase (original retail purchaser) is required for all warranty claims.
  2. Call or write Escalade® Sports to receive a Return Authorization # and determine specific needs.
- Phone: 1-888-USA-GOAL / Warranty Dept.  
Or Write Escalade® Sports at: Escalade® Sports - P.O. Box 889, Evansville, IN 47706 - Attn: Warranty Dept.  
Or E-mail us at: [basketball@escaladesports.com](mailto:basketball@escaladesports.com)