

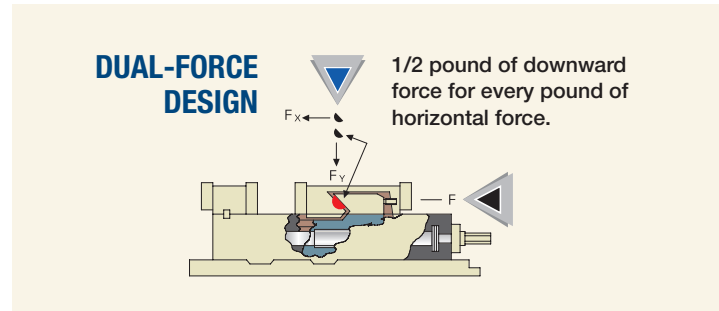

## DUAL FORCE PRECISION PREMIUM MACHINE VISES

Palmgren's premium CNC vises combines quality, high precision and wide clamping capacities at an affordable price. Ideal for everyday use from high production environments to rapid prototyping machine shops.

- Equipped with Dual Force anti-lift mechanism
- Sealed friction reducing needle thrust bearing help increase clamping pressure and reduce drag
- Vise nut does not extend beyond the end of the vise body
- Hardened jaw plates
- Hardened vise bed
- Repeatability within 0.001"
- Bed heights matched to +/- 0.0004"
- Parallelism of keyways on the bottom of the vise bed to the jaw face +/- 0.0008"
- 80,000 PSI stress relieved ductile iron castings



Item #	9625927	9625929	9625930	9625937
A	12.638	17.205	21.850	16.862
B	6.299	8.740	11.614	7.380
C	4.173	5.945	8.110	6.000
D	14.212	18.937	23.032	18.380
E	3.372	4.371	5.279	4.360
F	1.575	1.732	1.181	1.518
G	2.795	3.563	4.950	3.562
H	2.250	2.875	3.310	2.875
I	1.382	2.047	2.284	2.300
J	0.590	0.709	0.953	0.725
K	0.550	0.688	0.813	0.656
L	4.016	4.843	6.181	4.000
M	1.378	1.752	2.205	1.735
N	0.551	0.748	0.748	0.750
O	6.024	8.898	10.433	9.178
T	0.689	0.937	1.260	0.940
U	2.500	3.874	4.724	3.875
Weight	31 lbs.	80 lbs.	151 lbs.	65 lbs.

