

# SUMNER\*





A Southwire Company

## MAX JAX\* 2

- 4,500 lbs / 2141 kg load capacity
- 4 - 36" / pipe capacity
- Base reversible for 21." to 23" low or 26.5" to 36" high
- Drop slot roller wheel head offers more wheel contact with pipe
- Roll pipe through fab shop

(US and International Patents Pending)

Part # 786451 shown here

MAX JAX* 2 PRODUCT DETAILS	
	Roll pipe through fab shop and save crane time (shown with recommended hold down device)
	PN 781050 Hold Down Device is a recommended safety option to retain pipe on stand
	To Convert: 1. Remove head assembly 2. Loosen caster set screws 3. Rotate base 4. Mount casters and tighten set screws. 5. Install head
	PN 786450 MAX JAX* 2 complete with vee head and 4 roller wheels (PN 781381)

MAX JAX\* 2 base in high position for small diameter pipe

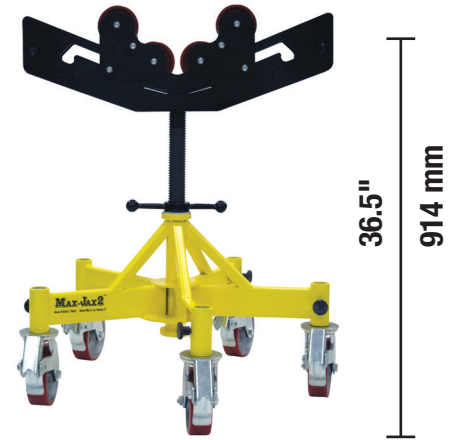

Hi Position

MAX JAX\* 2 base in low position for large diameter pipe

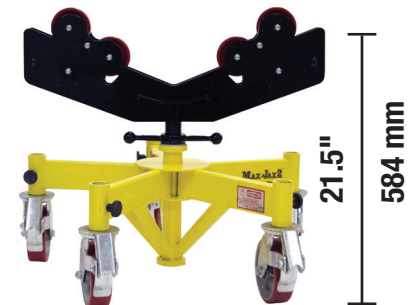

Lo Position

ITEM #	DESCRIPTION	MODEL #	UPC	MAXIMUM OPERATING HEIGHT	MINIMUM OPERATING HEIGHT	PIPE CAPACITY	LOAD CAPACITY	BASE WIDTH
786450	MAX JAX* 2 Kit w/ Large Vee & Rollers	MJAX2	661165864502	33"	21"	4" to 36"	4,500 lbs.	29.5"
786451	MAX JAX* 2 Kit w/ Drop Slot Head	MJAX2RR	661165864519	36.5"	21.5"	4" to 36"	4,500 lbs	29.5"