



Project Name: _____

Location: _____

Item #: _____ Qty: _____

Model: _____

UNDERCOUNTER REFRIGERATORS

MODEL: GRUCRF-27 GRUCRF-48 GRUCRF-60 GRUCRF-72



GRUCRF-27



GRUCRF-48



GRUCRF-60



GRUCRF-72

ELECTRIC

115V / 60Hz / 1Ph

8' (2.4m) NEMA 5-15P cord set included

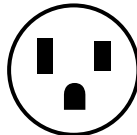

NEMA 5-15P

3RD PARTY APPROVALS



Intertek



Intertek

GRISTA WARRANTY (USA / CANADA)

Contact Admiral Craft for warranty statement at support@admiralcraft.com or 516.433.3535

Grista's Undercounter Refrigerators are constructed of heavy duty stainless steel making them strong and durable enough to survive in any kitchen environment. These units are perfect for adding more storage space anywhere you need. The flat stainless steel countertop allows for them to be used as a separate workstation. All undercounter units come with 4" casters and plastic coated wire shelving. These models are ETL Listed and ETL Sanitation. They are backed with a 2 year warranty on parts and labor and a 5 year warranty on the compressor

FEATURES AND CONSTRUCTION

- 430 series stainless steel exterior
- Painted aluminum interior
- Environmentally-friendly R290 refrigerant
- Precise digital temperature controller with LED display
- Foamed-in-place polyurethane high density cell insulation throughout the entire cabinet
- Automatic defrosting
- Removable door gasket
- Recessed door handles
- (4) 4" casters (2 locking and 2 non-locking)

NOMINAL STORAGE CAPACITY

GRUCRF-27	6.3 Cu Ft (178 L)
GRUCRF-48	12 Cu Ft (340 L)
GRUCRF-60	15 Cu Ft (425 L)
GRUCRF-72	15.5 Cu Ft (439 L)

TEMPERATURE

Holding Temperature 33°F to 40°F (1°C to 5°C)

- These models are designed to operate in an environment where temperature and humidity do not exceed 75°F (24°C) and 55% relative humidity

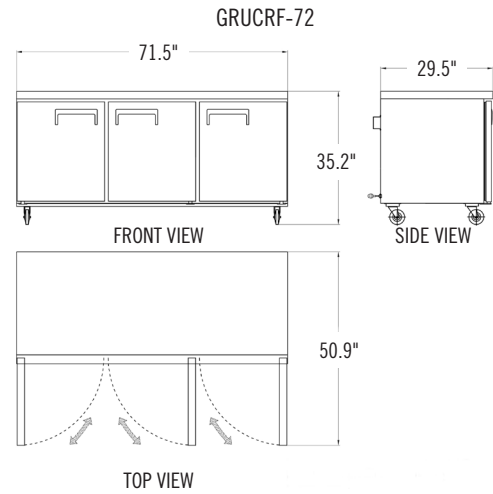
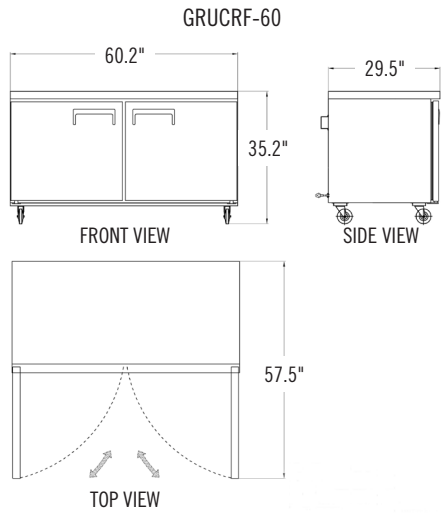
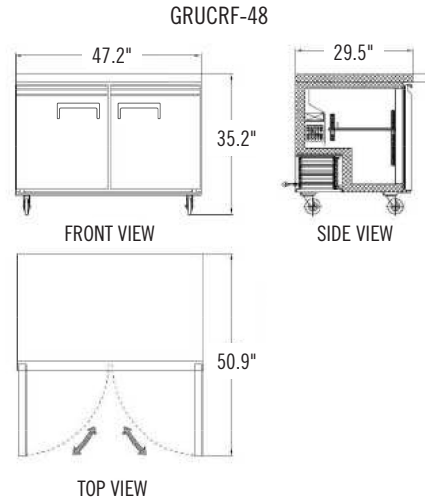
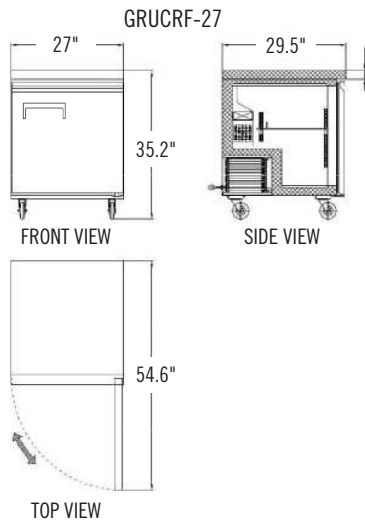

MODEL	GRUCRF-27	GRUCRF-48	GRUCRF-60	GRUCRF-72
Doors	1	2	2	3
Shelves	4	8	8	12
Net Volume (Cu Ft)	6.3 Cu Ft	12 Cu Ft	15 Cu Ft	15.5 Cu Ft
Overall Dimensions (in) WxDxH	27" x 29.5" x 35.2" (686 x 749 x 894mm)	47.2" x 29.5" x 35.2" (1199 x 749 x 894mm)	60.2" x 29.5" x 35.2" (1626 x 826 x 1092mm)	71.5" x 29.5" x 35.2" (2083 x 826 x 1092mm)
Interior Dimensions (in) WxDxH	22" x 23" x 23.5" (559 x 584 x 597mm)	42.5" x 23" x 23.5" (1080 x 584 x 597mm)	55.6" x 23" x 23.5" (1412 x 584 x 597mm)	66.9" x 23" x 23.5" (1699 x 584 x 597mm)
Refrigerant	R-290	R-290	R-290	R-290
Horsepower	1/6	1/5	3/5	3/4
Voltage/Hertz/Phase	115/60/1	115/60/1	115/60/1	115/60/1
Amps/Watts	1.9A/207W	2.7A/276W	7.14A/299W	7.08A/310W
Net Weight (lbs)	169 lbs (77 kg)	238 lbs (108 kg)	399 lbs (181 kg)	507 lbs (230 kg)
Gross Weight (lbs)	202 lbs (92 kg)	275 lbs (125 kg)	323 lbs (147 kg)	370 lbs (168 kg)
Shipping Dimensions (in) WxDxH	29.7" x 32.3" x 38.2" (754 x 820 x 970mm)	50" x 32.3" x 38.2" (1270 x 820 x 970mm)	63" x 32.3" x 38.2" (1600 x 820 x 970mm)	74.2" x 32.3" x 38.2" (1885 x 820 x 970mm)