

INSTALLATION INSTRUCTIONS FOR SLIMLINE® BEDPAN WASHER WITH EXPOSED ROYAL® AND REGAL® XL FLUSHOMETER



Slimline® Bedpan Washers

Royal BPW-1000 Standard
 Royal BPW-1005 With Deoseptic Unit
 Royal BPW-1010 With Retrofit Elbow
 Royal BPW-1015 With Retrofit Elbow & Deoseptic Unit
 Rrgal BPW-1000 XL Standard

Slimline® Bedpan Washers for ADA Installations

Royal BPW-1100 Standard
 Royal BPW-1105 With Deoseptic Unit
 Royal BPW-1110 With Retrofit Elbow
 Royal BPW-1115 With Retrofit Elbow & Deoseptic Unit
 Royal BPW-1150 With Grab Bar Offset
 Royal BPW-1155 With Grab Bar Offset & Deoseptic Unit
 Regal BPW-1100 XL Standard
 Regal BPW-1150 XL With Grab Bar Offset

Slimline® Bedpan Washers — Diverter Assemblies

DV-100 Standard
 DV-105 With Deoseptic Unit
 DV-110 For ADA Installation
 DV-115 For ADA Installation With Deoseptic Unit
 DV-120 With Grab Bar Offset
 DV-125 With Grab Bar Offset & Deoseptic Unit
 DV-130 Replacement Model
 DV-135 Replacement Model With Deoseptic Unit

LIMITED WARRANTY

Sloan Valve Company warrants its Slimline Bedpan Washer to be made of first class materials, free from defects of material or workmanship under normal use and to perform the service for which they are intended in a thoroughly reliable and efficient manner when properly installed and serviced, for a period of three years (1 year for special finishes) from date of purchase. During this period, Sloan Valve Company will, at its option, repair or replace any part or parts which prove to be thus defective if returned to Sloan Valve Company, at customer's cost, and this shall be the sole remedy available under this warranty. No claims will be allowed for labor, transportation or other incidental costs. This warranty extends only to persons or organizations who purchase Sloan Valve Company's products directly from Sloan Valve Company for purpose of resale.

THERE ARE NO WARRANTIES WHICH EXTEND BEYOND THE DESCRIPTION ON THE FACE HEREOF. IN NO EVENT IS SLOAN VALVE COMPANY RESPONSIBLE FOR ANY CONSEQUENTIAL DAMAGES OF ANY MEASURE WHATSOEVER.

PRIOR TO INSTALLATION

Before you install the Sloan Bedpan Washer and Flushometer, be sure the items listed below are installed. Also, refer to the rough-in diagram below.

- Closet fixture
- Drain line
- Water supply line

Important:

- **ALL PLUMBING SHOULD BE INSTALLED IN ACCORDANCE WITH APPLICABLE CODES AND REGULATIONS.**
- **WATER SUPPLY LINES MUST BE SIZED TO PROVIDE AN ADEQUATE VOLUME OF WATER FOR EACH FIXTURE.**
- **FLUSH ALL WATER LINES PRIOR TO MAKING CONNECTIONS.**

The Sloan Royal® and Regal® XL Flushometers are designed to operate with 10 to 100 psi (69 to 689 kPa) of water pressure. **THE MINIMUM PRESSURE REQUIRED TO THE VALVE IS DETERMINED BY THE TYPE OF FIXTURE SELECTED.** Consult fixture manufacturer for minimum pressure requirements. Most Low Consumption water closets (1.6 gpf/6.0 Lpf) require a minimum flowing pressure of 25 psi (172 kPa).

TOOLS REQUIRED FOR INSTALLATION

- Straight blade screwdriver
- Sloan A-50 Super-Wrench™, Sloan A-109 Plier Wrench or smooth jawed spud wrench

VALVE ROUGH-IN

STANDARD INSTALLATION

BPW 1000/1005

DV-100/105

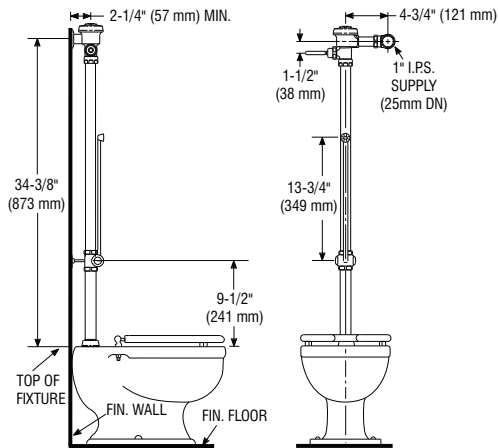

RETROFIT INSTALLATIONS

BPW 1010/1015

DV-100/105-R

USE WHEN INSTALLING WITH EXISTING WATER SUPPLY ROUGH-IN

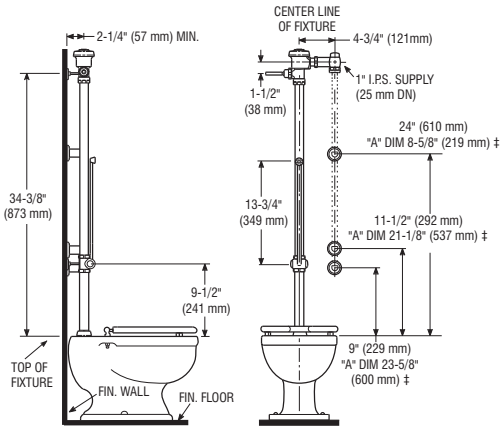

‡ DIMENSION "A" IS LENGTH OF PIPE REQUIRED TO RAISE THE SUPPLY TO THE CONTROL STOP. ELBOW FITTING SUPPLIED.

ADA INSTALLATION

BPW 1100/1105

DV-110/115

USE WHEN VALVE MUST MEET 44" (1118 mm) MAX. HANDLE HEIGHT REQUIREMENT PER THE AMERICANS WITH DISABILITIES ACT

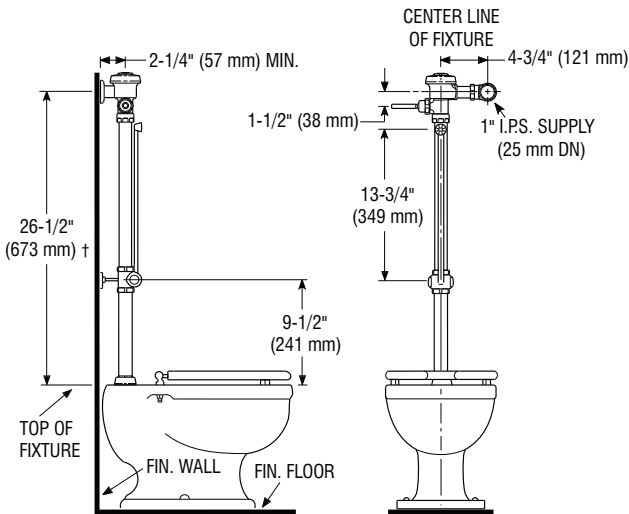

† IF VALVE IS NOT PROVIDED WITH 13-1/2" (343 mm) V-600-AA VACUUM BREAKER, CUT VACUUM BREAKER TUBE TO SIZE TO MEET ROUGH-IN HEIGHT.

FLUSH VOLUME

BPW VALVE CAN BE PROVIDED WITH THE FOLLOWING FLUSHING VOLUMES:

- Standard — Water Saver, 3.5 gpf (13.2 Lpf)
- "-1.6" — Low Consumption, 1.6 gpf (6.0 Lpf)
- "-2.4" — 2.4 gpf (9.0 Lpf) – European Standard

These instructions also for use with Slimline Bedpan Washers with Sloan Naval, Dolphin, and GEM Flushometers.

BPW RETROFIT WITH 2" OFFSET DV-130/135

USED TO REPLACE OLD STYLE AMERICAN STERILIZER AND CHICAGO FAUCET BEDPAN WASHERS

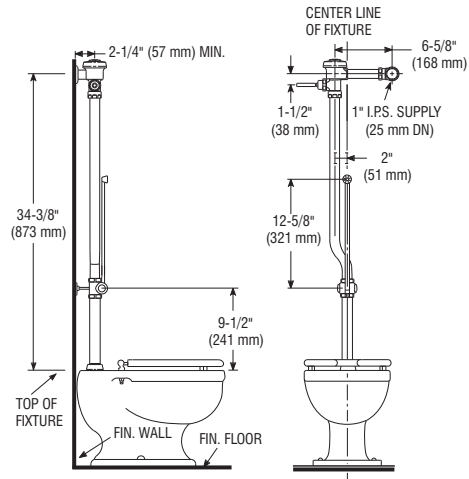

BPW-1150/1155

DV-120/125

USE WHEN INSTALLATION REQUIRES CLEARANCE AROUND GRAB BARS

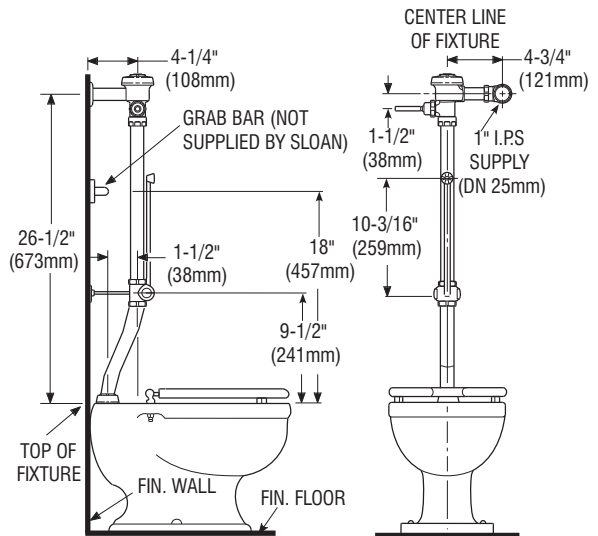

!!! IMPORTANT !!!

With the exception of Control Stop Inlet, DO NOT use pipe sealant or plumbing grease on any valve component or coupling!

!!! IMPORTANT !!!

Protect the chrome or special finish of Sloan Flushometers — DO NOT USE toothed tools to install or service these valves. Use a Sloan A-50 Super-Wrench™, Sloan A-109 Plier Wrench or smooth jawed spud wrench to secure all couplings. Also see "Care and Cleaning" section of this manual.

!!! IMPORTANT !!!

This product contains mechanical and/or electrical components that are subject to normal wear. These components should be checked on a regular basis and replaced as needed to maintain the valve's performance.

If you have questions about how to install your Sloan Flushometer, consult your local Sloan Representative or call Sloan Installation Engineering Department at:

1-888-SLOAN-14 (1-888-756-2614) OR 1-847-233-2016

1 - INSTALL OPTIONAL SWEAT SOLDER ADAPTER (ONLY IF YOUR SUPPLY PIPE DOES NOT HAVE A MALE THREAD)

- A** Measure from finished wall to C/L of Fixture Spud. Cut pipe 1¼" (32 mm) shorter than this measurement. Chamfer O.D. and I.D. of water supply pipe.
- B** Slide Threaded Adapter fully onto pipe.
- C** Sweat solder the Adapter to pipe.

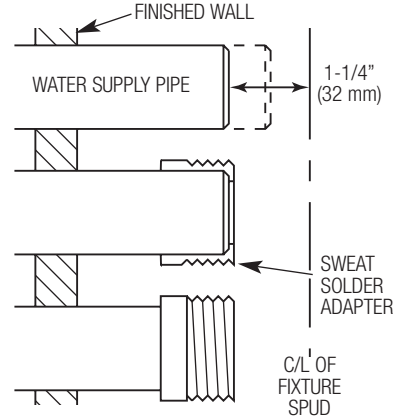

!!! IMPORTANT !!!

With the exception of Control Stop Inlet, DO NOT use pipe sealant or plumbing grease on any valve component or coupling!

2 - INSTALL COVER TUBE, WALL FLANGE, AND CONTROL STOP TO SUPPLY PIPE

- A** Measure from finished wall to first thread of Adapter or threaded supply pipe (dimension "X"). Cut Cover Tube to this length.
- B** Slide Cover Tube over pipe. Slide Wall Flange over Cover Tube until against wall.
- C** Thread Control Stop onto pipe. Tighten with a wrench.

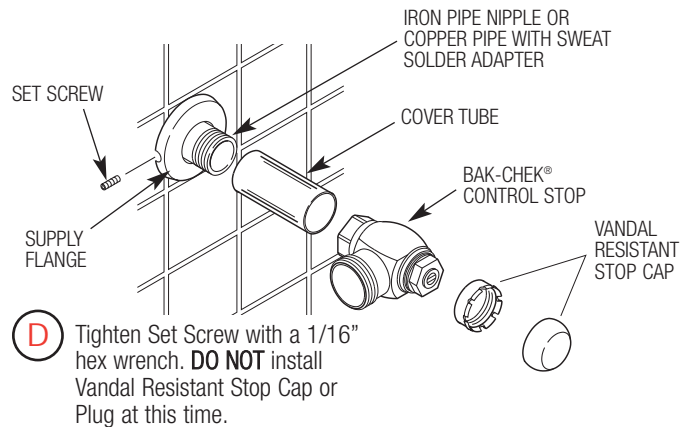
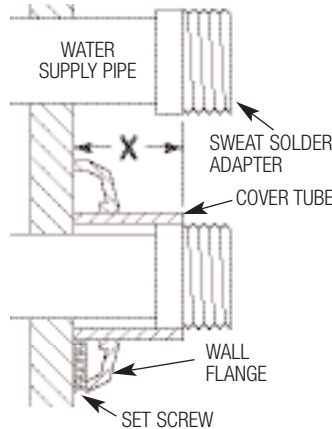

- D** Tighten Set Screw with a 1/16" hex wrench. **DO NOT** install Vandal Resistant Stop Cap or Plug at this time.

3 - INSTALL FLANGED OUTLET TUBE (RETROFIT APPLICATIONS START HERE)

- A** Slide the diverter valve coupling nut, spud coupling, nylon slip gasket, rubber gasket and spud flange over the flanged outlet tube and insert tube into fixture spud. Place tube gasket on top of flanged outlet tube as shown.
- B** Hand tighten spud coupling onto fixture spud.
- C** Place tube gasket on top of flanged outlet tube as shown.

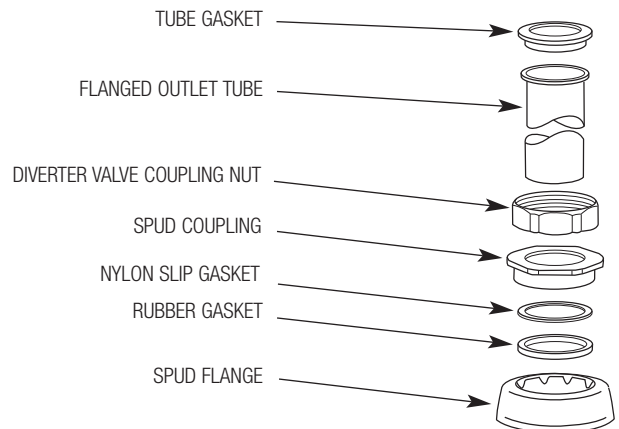

4 - INSTALL DIVERTER VALVE AND WALL SUPPORT FLANGE

- A** Position diverter valve on top of tube gasket and secure with diverter valve coupling nut; tightening hand tight.

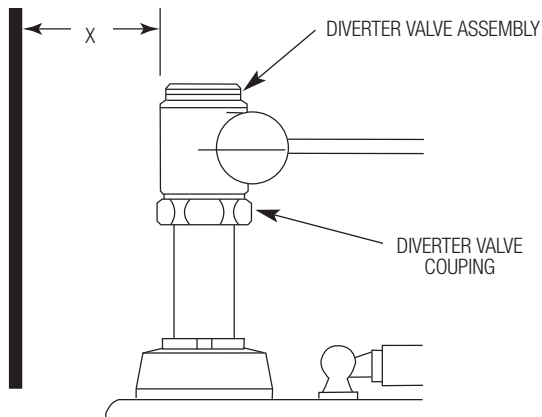

- B** Determine required length of support rod by measuring distance between finish wall and back of diverter valve at support rod hole. Add 1/4" (6 mm) to the length determined and cut the support rod to size.
- C** Turn the diverter valve assembly to allow threading support rod into back of diverter body. Slide wall support flange onto support rod and turn the diverter valve assembly so that the wall support flange is flush with wall.

- D** Use the wall support flange as a template and mark off holes on finished wall for mounting screws. Remove diverter valve assembly and drill two 5/16" (8 mm) holes at the locations marked. Install an anchor in each hole.
- E** Position the diverter valve on top of adapter ring and secure with diverter valve coupling; tightening hand tight. Rotate diverter valve so that the support rod flange mounting holes are aligned with the mounting holes in the finished wall.
- F** Secure flange with the two (2) screws provided. Tighten set screw in wall support flange.

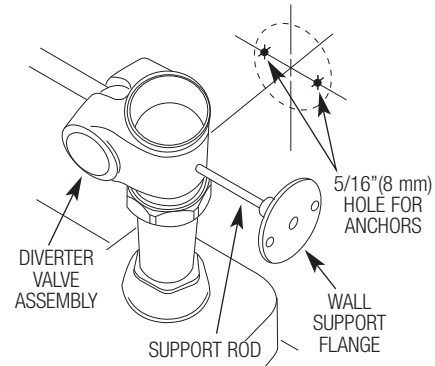

5 - INSTALL DEOSEPTIC UNIT (9005 MODELS ONLY)

- A** Connect aspirator tube to deoseptic swivel.
- B** Screw bottle onto deoseptic swivel.

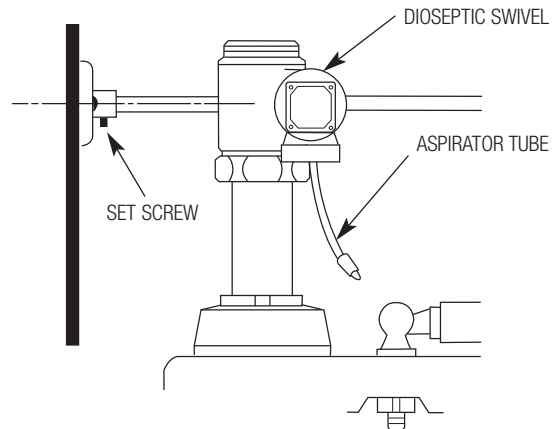

6 - INSTALL VACUUM BREAKER FLUSH CONNECTION

- A** Slide the diverter valve coupling nut, nylon slip gasket and rubber gasket over the vacuum breaker tube and secure tube to diverter valve.
- B** Hand tighten diverter valve coupling nut onto diverter valve assembly.
- C** Length of vacuum breaker tube may be shortened to accommodate lower valve installation height.

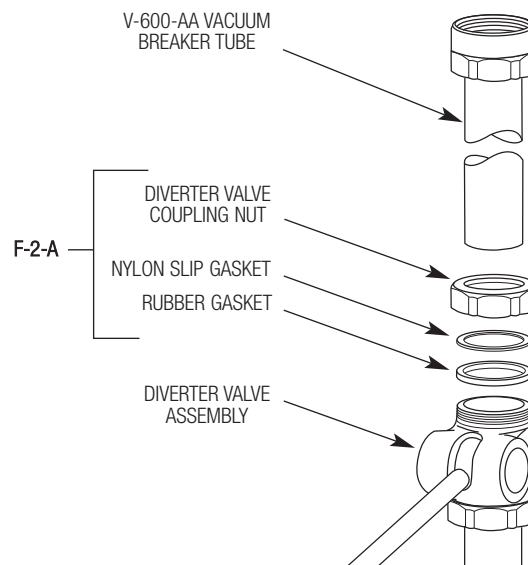

7 - INSTALL FLUSHOMETER

- A** Lubricate tailpiece O-ring with water. Insert Adjustable Tailpiece into Control Stop. Tighten Tailpiece Coupling by hand.
- B** Align Flushometer directly above the Vacuum Breaker Flush Connection by sliding the Flushometer Body IN or OUT as needed. Tighten Vacuum Breaker Coupling by hand.

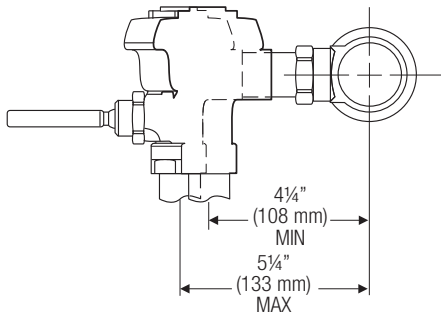

NOTE

Maximum adjustment of the Sloan Adjustable Tailpiece is 1/2" (13 mm) IN or OUT from the standard 4-3/4" (121 mm) (centerline of Flushometer to centerline of Control Stop).

If roughing-in measurement exceeds 5-1/4" (133 mm), consult factory for longer tailpiece.

- C** Align Flushometer Body and securely tighten first the Tailpiece Coupling (1), then the Vacuum Breaker Coupling (2), and finally the Spud Coupling (3). Use a wrench to tighten these couplings in the order shown.

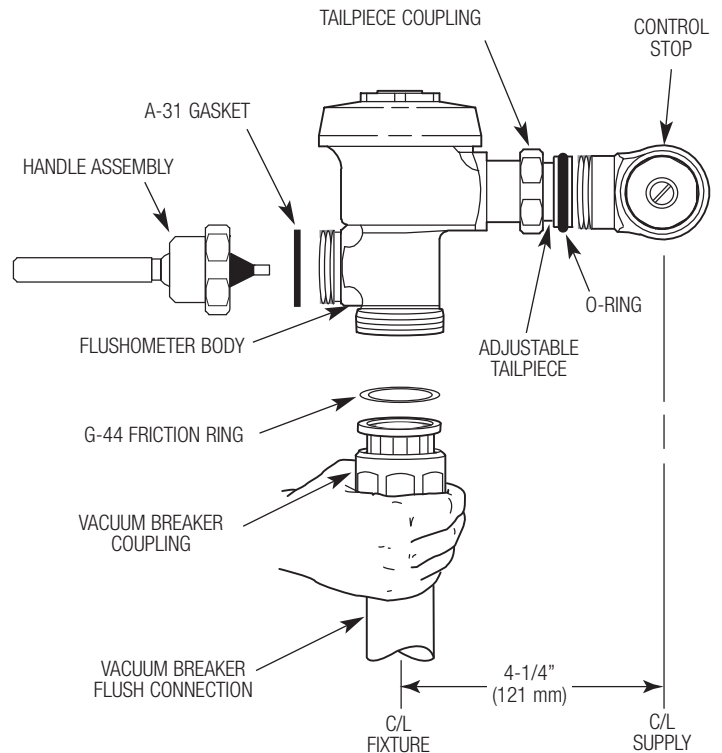

8 - FLUSH OUT SUPPLY LINE

- A** Make sure Control Stop is CLOSED and remove Flushometer Outer Cover.
- B** Remove Inside Cover and lift out Inside Parts Assembly.

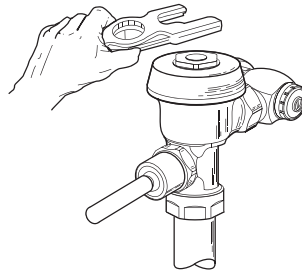

- C** Reinstall Outside and Inside Cover wrench tight. Open Control Stop to flush supply line. Close Control Stop and remove Outside and Inside Cover.

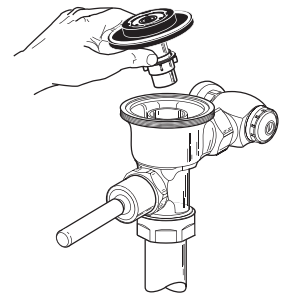

- D** Reinstall Inside Parts Assembly, Inside Cover and Outside Cover wrench tight.

9 - INSTALL CONTROL STOP AND VANDAL RESISTANT STOP CAP OR PLUG

- A** Open Control Stop COUNTERCLOCKWISE one FULL turn from closed position.

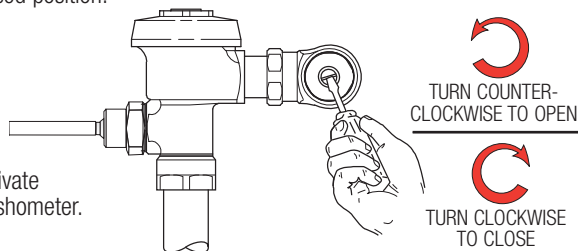

- B** Activate Flushometer.

- C** Adjust Control Stop after each flush until the rate of flow delivered properly cleanses the fixture.

!!! IMPORTANT !!!

The Sloan Flushometer is engineered for quiet operation. Excessive water flow creates noise, while too little water flow may not satisfy the needs of the fixture. Proper adjustment is made when plumbing fixture is cleansed after each flush without splashing water out from the lip AND a quiet flushing cycle is achieved.

- D** Install Vandal Resistant Control Stop Cap onto Control Stop (Or if you have a Regal XL, install Control Stop Plug into Control Stop.).

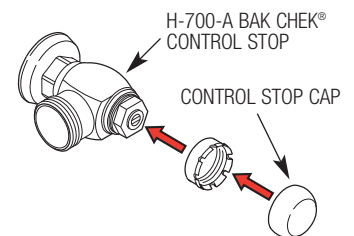

10 - ADJUST VOLUME OF SOLUTION DRAWN FROM DEOSEPTIC BOTTLE (9005 MODELS ONLY)

A Using a screwdriver blade, pry off plug button on side of deoseptic swivel. Turn deoseptic adjustment screw as follows:

 Clockwise to DECREASE volume of solution drawn during flush

 Counterclockwise to INCREASE volume of solution drawn during flush

B Replace plug button after making adjustment.

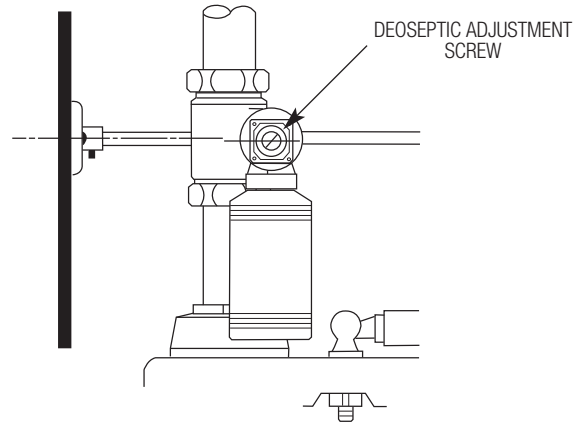

VANDAL RESISTANT CONTROL STOP / PLUG REMOVAL INSTRUCTIONS

A Using a large flat screwdriver, gently lift the Cap from the Control Stop as follows. Insert the screwdriver blade between the bottom edge of the Cap and the flat surface of the Control Stop body as shown. Using the screwdriver as a lever, push the screwdriver handle straight back towards the wall. Gently lift the Cap from the Sleeve. It may be necessary to work the screwdriver around the diameter of the cap to further lift the Cap from the Sleeve.

B Once the Cap has been lifted away from the Control Stop, grasp the Cap and pull it off the Sleeve.

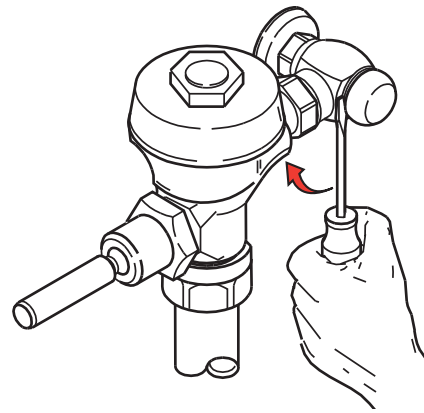

CARE AND CLEANING

DO NOT USE abrasive or chemical cleaners (including chlorine bleach) to clean Flushometers as they may dull the luster and attack the chrome or special decorative finishes. Use **ONLY** soap and water, then wipe dry with clean cloth or towel.

While cleaning the bathroom tile, the Flushometer should be protected from any splattering of cleaner. Acids and cleaning fluids can discolor or remove chrome plating.

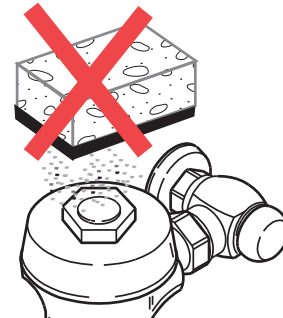

MAINTENANCE OF DIVERTER AND DEOSEPTIC

Cleaning Nozzle Spray Disc and Screen

Remove spray disc retainer by turning counterclockwise. Remove spray disk and screen, and clean with water. Reinstall screen, spray disc and spray disc retainer. Tighten spray disc retainer hand tight.

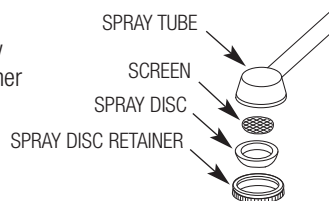

Refilling Deoseptic Bottle

Remove deoseptic bottle by turning counterclockwise. Fill deoseptic bottle with fluid and reinstall. Tighten deoseptic bottle hand tight.

Cleaning Aspirator Tube

Remove deoseptic bottle by turning counterclockwise. Remove aspirator tube, clean with warm water and reinstall. Fill deoseptic bottle with fluid if necessary and reinstall. Tighten deoseptic bottle hand tight.

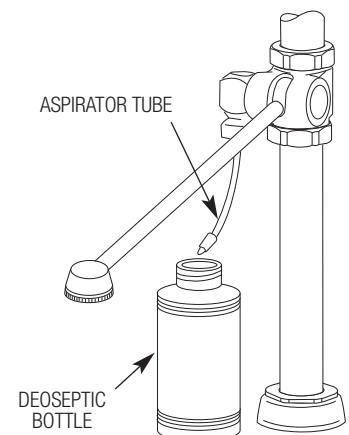

TROUBLESHOOTING

See Royal, Naval, Dolphin, GEM, Sloan and Regal XL Flushometers Troubleshooting and Maintenance Guide for all problems regarding the flushometer valve and the flushing discharge.

1. PROBLEM: Diverter leaking at Spray Arm.

CAUSE: (a.) Diverter Spray Arm (old style) is damaged.
(b.) Spray Arm O-Ring is damaged or installed improperly.

SOLUTION: (a.) Replace Diverter Arm with new Spray Arm Replacement Kit.

NOTE: On old style diverter Spray Arm, the Spray Arm O-Ring was placed on groove at the end of the Spray Arm. When installing new Spray Arm Kit, place Washer into bottom of hole of Nozzle Pivot. Then place the O-Ring on top of Washer. Insert new Spray Arm into the Pivot, pressing in slightly. While holding Spray Arm in place, tighten Set Screw.

(b.) Re-install O-Ring as described above in step
(a.) If leakage persists replace using Spray Arm Kit DV-1007-A.

2. PROBLEM: Diverter leaking at Nozzle Pivot.

CAUSE: (a.) One or both Pivot O-Rings are worn.
(b.) Diverter Seal Washer worn or missing.
(c.) Nozzle Pivot damaged or defective.

SOLUTION: (a.) Replace Nozzle Pivot Assembly. Use Pivot Replacement Kit.
(b.) Replace Pivot Seals. Use Diverter Rebuild Kit.
(c.) Replace Nozzle Pivot Assembly. Use Pivot Replacement Kit.

3. PROBLEM: Erratic spray pattern from Spray Arm Nozzle.

CAUSE: (a.) Debris clogging Nozzle Screen.
(b.) Damaged or missing Nozzle Screen or Spray Disc.

SOLUTION: (a.) Wash Nozzle Screen under running water.
(b.) Replace using DV-1007-A Spray Arm Replacement Kit.

4. PROBLEM: Deoseptic Solution not siphoning from Bottle during flush cycle (Deoseptic models only).

CAUSE: (a.) Adjusting Screw not open.
(b.) Aspirator Tube Screen clogged.
(c.) Aspirator Tube not installed completely onto Swivel & Ball Check Assembly.
(d.) Aspirator Tube cracked.
(e.) Rubber Ball Check stuck inside Swivel & Ball Check Assembly.

SOLUTION: (a.) Open Adjusting Screw until adequate amount of solution is siphoned from Bottle during flush cycle.
(b.) Remove Solution Bottle. Remove Aspirator Tube from Swivel & Ball Check Assembly and wash Screen under running water.
(c.) Remove Solution Bottle. Make sure Aspirator Tube is pushed completely onto nipple of Swivel and Ball Check Assembly.
(d.) Replace Aspirator Tube Assembly.
(e.) Remove Solution Bottle and Aspirator Tube from Swivel & Ball Check Assembly. Gently insert small implement (paper clip, small dia. hex key, etc.) into nipple of Swivel & Ball Check Assembly to dislodge Rubber Ball Check. Stop pushing once water starts to trickle from nipple.

NOTE: If Ball is pushed too hard or too far it may fall out of seat. Should this occur, the Swivel & Ball Check Assembly must be removed and Ball replaced. To do this, remove Retaining Ring using retaining clip pliers. Pull Swivel & Ball Check Assembly off of Adjusting Screw being careful not to drop Rubber Ball Check. Place Rubber Ball back into seat of Swivel & Ball Check Assembly and reassemble. If Ball and Seals appear worn rebuild.

5. PROBLEM: Water leaking back into Solution Bottle.

CAUSE: (a.) Rubber Ball damaged or missing.
(b.) Rubber Ball not sitting in seat of Swivel & Ball Check Assembly.

SOLUTION: (a.) Replace Rubber Ball using DV-1004-A Deoseptic Diverter Rebuild Kit
(b.) Remove Swivel & Ball Check Assembly taking care not to lose Rubber Ball. Insert Rubber Ball back into seat of Swivel & Ball Check Assembly and reassemble.

NOTE: Follow steps in Solution (e.) of Problem 4.

REBUILDING THE SLOAN SLIMLINE DIVERTER ASSEMBLY:

To disassemble Diverter Valve:

Loosen Set Screw and remove Spray Arm from Pivot. Slide Pivot out of Diverter Valve Body.

To further disassemble Deoseptic Diverter:

Remove Plug Cap and Retaining Ring. Slide Swivel and Ball Check Assembly off Pivot shaft, exposing all internal components.

NOTE: This disassembly can be done without removing Pivot Assembly from Diverter Valve Body.