

# TRADITIONAL GAZING GLOBE STAND

Review all assembly and care information before using this product. Save this manual for future reference.

**Assemble components on a soft, clean surface to avoid damaging the finish.**

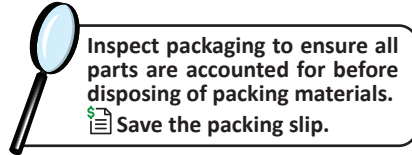
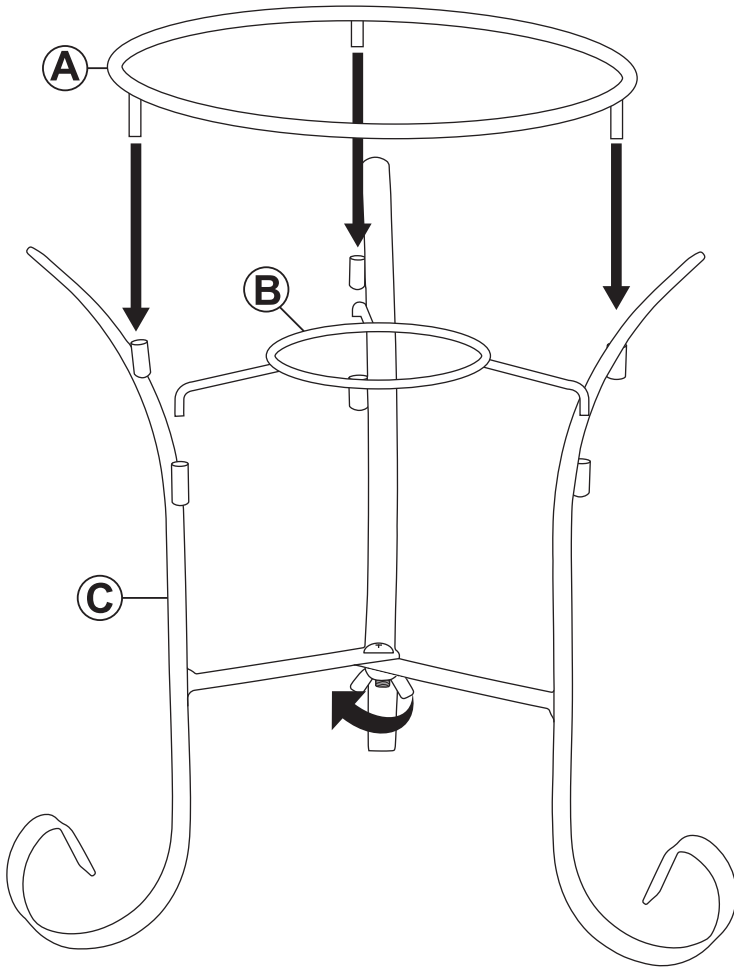

**SCAN TO  
VIEW OUR  
ASSEMBLY  
VIDEO**

No.	PARTS	QTY.
A	Top Ring	1
B	Inner Ring	1
C	Frame	1

## ASSEMBLY

1. Unfold Frame (C) and place it on a level surface.
2. Affix Inner Ring (B) to the lower spaces on the frame.
3. Affix Top Ring (A) to the upper spaces of the frame.
4. Hand-tighten the wing nut on the bottom of the frame; do not over-tighten.

**NOTE:** The rings are intended to fit snugly in the frame, minor force may be necessary to align the rings with the frame.

## USE & CARE

- Choose a flat, level location to place the stand.
- Avoid high-traffic areas such as locations where children and pets play.
- Occasionally check the wing nut on the bottom of the frame to ensure it is intact.

## CLEANING

Wipe the stand down with warm water and a soft cloth.

## ⚠ IMPORTANT INFORMATION ⚠

- To prevent rusting, store indoors during the winter and inclement weather conditions.
- Remove the gazing globe (not included) from the stand during windy conditions.
- Do not bend the metal.

**Any modification to the product or failure to follow recommended care will void the product warranty.**

*If you experience issues with assembly or the product was damaged during shipping, please contact our customer service team through one of the methods mentioned at the top of page 1. Please have the item number and order information ready to expedite response time.*

## ⚠ WARNING:

**Manufacturer and seller expressly disclaim any and all liability from personal injury, property damage or loss, whether direct or indirect, or incidental, resulting from the incorrect attachment, improper use, inadequate maintenance, or neglect of this product.**