

SMART HEXAGON LIGHT TILES

IMPORTANT SAFETY INSTRUCTIONS AND INSTALLATION GUIDE

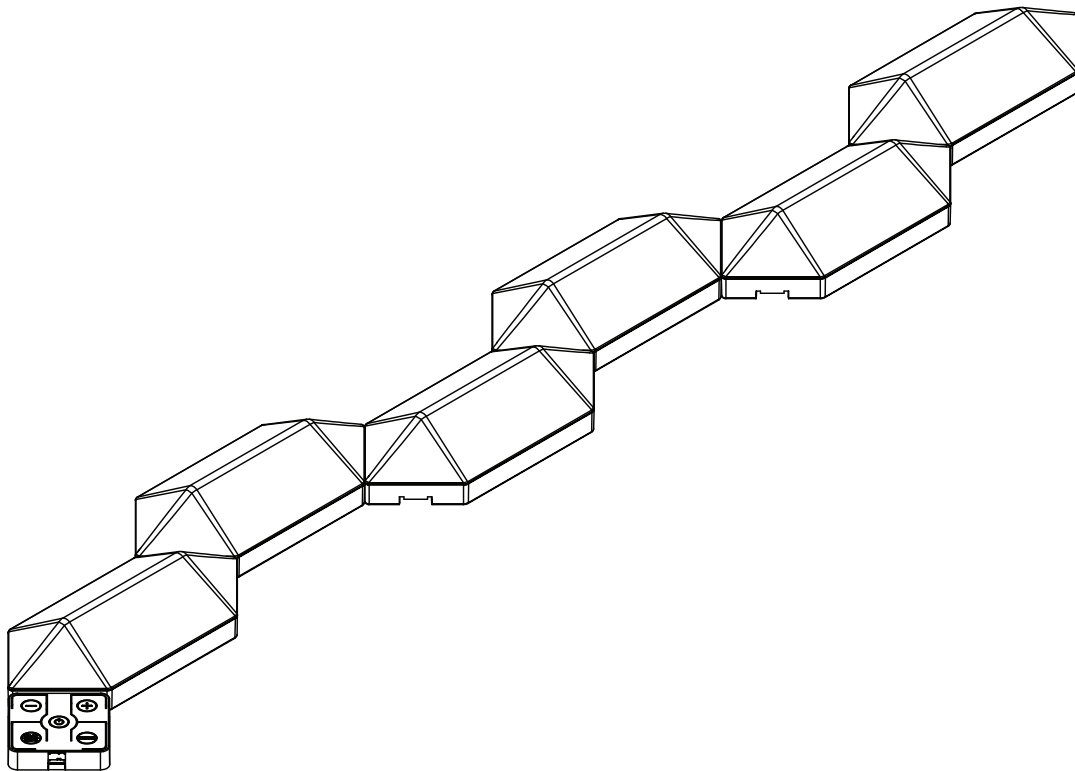

READ BEFORE INSTALLATION
SAVE THESE INSTRUCTIONS

Questions, problems, missing parts? Before returning to the store,
call Feit Electric Customer Service
8 a.m. - 5 p.m., PST, Monday - Friday

1-866-326-BULB (2852)

FEIT.COM

Table of Contents

Table of Contents	2
Important Safety Information	2
FCC Statement	2
Limited Warranty	2
Product Dimension	3
Pre-Installation	3
Operating Instructions	3
Troubleshooting Tips	3
Installation	4
Getting Started	5
Mounting Bracket Template	6

Important Safety Information

SAVE THESE INSTRUCTIONS

IMPORTANT SAFEGUARDS:

ALWAYS FOLLOW BASIC SAFETY PRECAUTIONS WHEN USING ELECTRICAL PRODUCTS, ESPECIALLY WHEN CHILDREN ARE PRESENT.

Product Specifications:

120VAC, 60Hz, 24 Watts Max
Dimmable with LED Controller
Suitable for Damp Locations

Supplier's Declaration of Conformity: 47 CFR § 2.1077 Compliance Information

Responsible Party: Feit Electric Company 4901 Gregg Road, Pico Rivera, CA 90660, USA 562-463-2852

Unique Identifier: HEX/CHASE/AG/6KIT

FCC STATEMENT

This device complies with part 15 of the FCC Rules. Operation is subject to the following two conditions: (1) This device may not cause harmful interference, and (2) this device must accept any interference received, including interference that may cause undesired operation. Note: This equipment has been tested and found to comply with the limits for a Class B digital device, pursuant to part 15 of the FCC Rules. These limits are designed to provide reasonable protection against harmful interference in a residential installation. This equipment generates, uses and can radiate radio frequency energy and, if not installed and used in accordance with the instructions, may cause harmful interference to radio communications. However, there is no guarantee that interference will not occur in a particular installation. If this equipment does cause harmful interference to radio or television reception, which can be determined by turning the equipment off and on, the user is encouraged to try to correct the interference by one or more of the following measures: Reorient or relocate the receiving antenna. Increase the separation between the equipment and receiver. Connect the equipment into an outlet on a circuit different from that to which the receiver is connected. Consult the dealer or an experienced radio/TV technician for help. Any changes or modifications not expressly approved by the manufacturer could void the user's authority to operate the equipment.

Radiation Exposure Statement

This device complies with FCC radiation exposure limits set forth for an uncontrolled environment. This device should be installed and operated with a minimum distance of 20cm between the radiator and your body.

Limited Warranty

This product is warranted to be free from defects in workmanship and materials for up to 1 year from date of purchase. If the product fails within the warranty period, please visit feit.com/help for instructions on replacement/refund or call 866.326.BULB. REPLACEMENT OR REFUND IS YOUR SOLE REMEDY. EXCEPT TO THE EXTENT PROHIBITED BY APPLICABLE LAW, ANY IMPLIED WARRANTIES ARE LIMITED IN DURATION TO THE DURATION OF THIS WARRANTY. LIABILITY FOR INCIDENTAL OR CONSEQUENTIAL DAMAGES IS HEREBY EXPRESSLY EXCLUDED. Some states and provinces do not allow the exclusion of incidental or consequential damages, so the above limitation or exclusion may not apply to you. This warranty gives you specific legal rights, and you may also have other rights which vary from state to state or province to province.



CAUTION: Do not attempt to install while plugged in. This fixture is for indoor use only. Not for use with plastic cabinets. Do not install this fixture inside a totally enclosed cabinet. Do not mount over stoves.



WARNING: To avoid risk of electrical shock, always make sure the product is unplugged from the electrical outlet before assembling, disassembling, relocating, servicing or cleaning it.



CAUTION: Do not install this product in a wet location.



CAUTION: Do not install this product in an outdoor location.



CAUTION: Do not use chemical solvents or harsh abrasives to clean the fixture.

Product Dimension

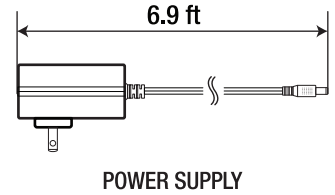
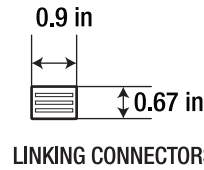
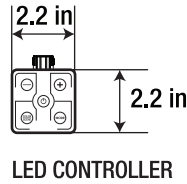
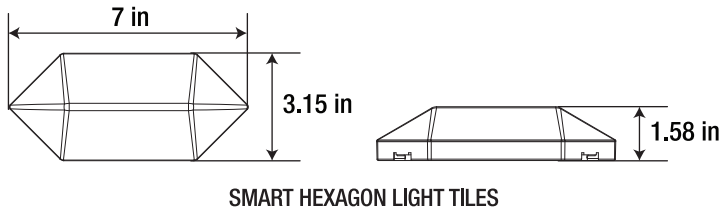

Pre-Installation

DRAWINGS NOT TO SCALE.

TOOLS REQUIRED (NOT INCLUDED)

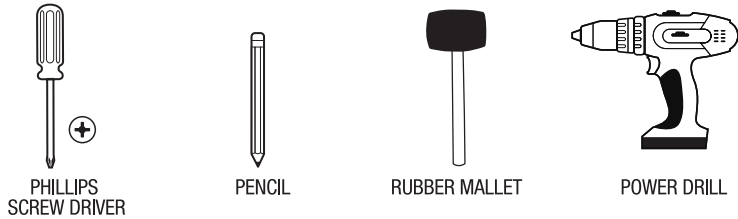

NOTE: Hardware not shown to actual size.

HARDWARE INCLUDED

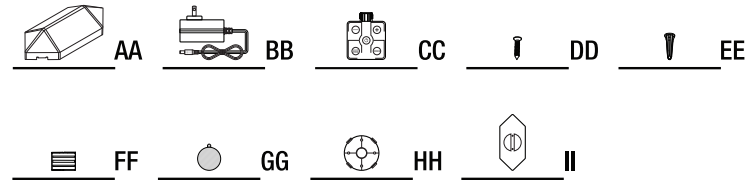

Part	Description	Quantity
AA	Smart Hexagon Light Tiles	6
BB	Power Supply	1
CC	LED Controller	1
DD	Mounting Screw	12
EE	Mounting Anchor	12
FF	Linking Connectors	6
GG	Mounting Tape	6
HH	Mounting Bracket	6
II	Mounting Bracket Template	1

Item No.	Description	Maximum Wattage (W)	Wattage Per Panel (W)	Maximum Linkable Units
HEX/CHASE/AG/6KIT	Smart Hexagon Light Tiles	24	2	DO NOT EXCEED MORE THAN 12 PANELS

Operating Instructions

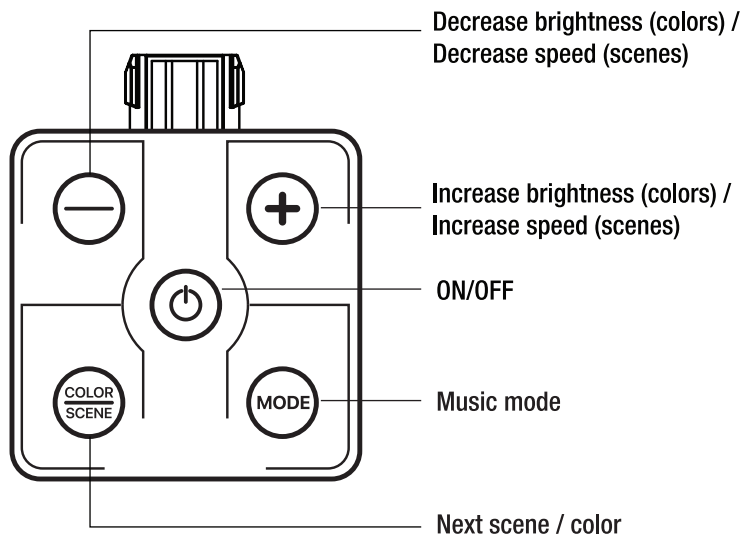

Troubleshooting Tips

Disconnect the power supply then plug it back in. Press the "ON/OFF" button to confirm it is turned on. Ensure the power supply, LED controller, and the light tiles are properly connected. Ensure the linking connectors are pointing outward from the connecting light. The lights tiles will freeze or cycle through colors if it is incorrect.

If you are having difficulty connecting the light tiles to Wi-Fi: Make sure the Wi-Fi network is a 2.4 GHz network. The smart hexagon light tiles will not connect to a 5 GHz network. Test your Wi-Fi network with other devices such as your phone to make sure it is operating properly. The Wi-Fi connection may not have good coverage during set up. Try moving the smart hexagon light tiles closer to your Wi-Fi router. Your Wi-Fi network password is case sensitive, make sure you are entering it correctly.

Check the App User Guide or visit www.feit.com/help for more information and assistance.

Installation

1 Position the Fixture

Find the desired place for the smart hexagon light tile (AA) and mark clearly using the provided mounting bracket template (II).

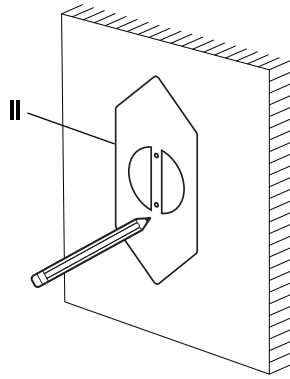

IMPORTANT: The location must be able to be reached by the cable from the power supply. For Smart Control, ensure the location has good Wi-Fi coverage.

2 Installing the Mounting Bracket

Using a 3/16 in. drill bit, drill two holes on your marked locations. Insert the mounting anchors into the holes using a rubber mallet (not included). Apply the mounting tape (GG) to the back of the mounting bracket (HH) (ensure that the tape is inside of the circle and not obstructing the mounting screw holes). Align the screw holes on the mounting bracket (HH) with the holes on the wall and screw in the mounting screws (DD).

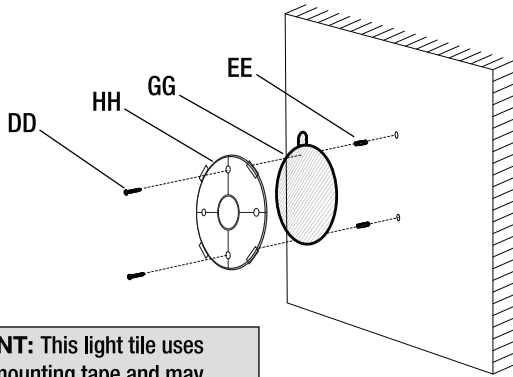

IMPORTANT: This light tile uses permanent mounting tape and may cause surface damage if removed. Not recommended for mounting on brick or concrete. Feit Electric is not responsible for damage to mounted surfaces.

3 Installing the LED Fixture

Align the back of the smart hexagon light tile (AA) with the mounting bracket (HH) and press it in firmly.

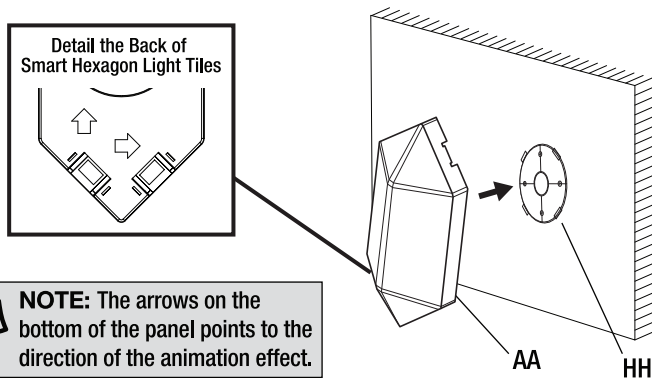

NOTE: The arrows on the bottom of the panel points to the direction of the animation effect.

4 Adding Extra Panels

To add extra panels, connect the linking connector (FF) to the linking port of the mounted smart hexagon light tile (AA). Use your mounting bracket template (II) to mark your desired mounting location. Ensure that the arrow on the linking connector (FF) points outward from the connected light. Then repeat step 3.

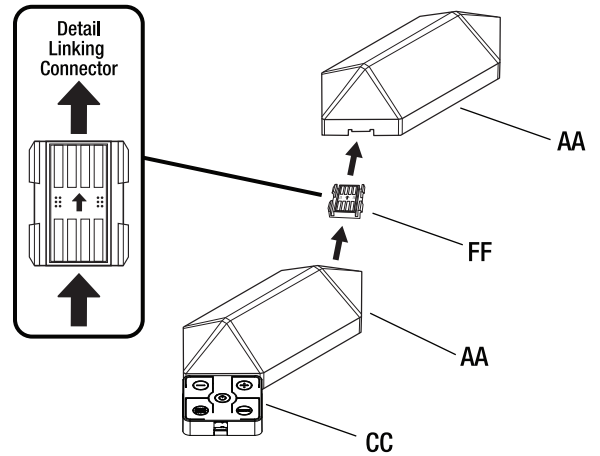

5 Connecting the Power Supply and LED Controller

Plug the LED Controller (CC) to the first smart hexagon light tile (AA), then plug the power supply (BB) into the LED Controller (CC).

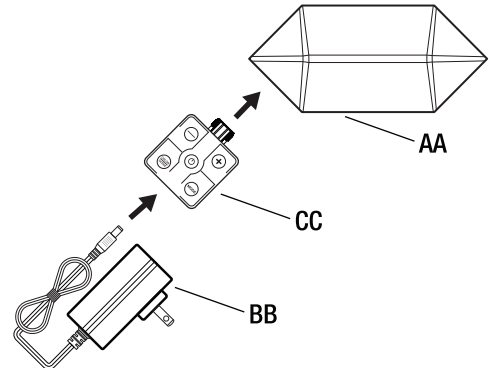

IMPORTANT: Do not plug in electrical plug to a wall power source until after connecting to the LED Fixture (AA).

6 Connecting to a Power Outlet

Connect the power supply (BB) to the power outlet on the wall.

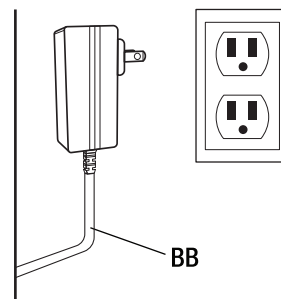

Getting Started:

1 Download the Feit Electric App on Your Smart Device



Feit Electric app



2 Install Your Smart Hexagon Light Tiles

See "Installation" Section on page 4.

3 Plug in Your Smart Hexagon Light Tiles

Plug the Smart Hexagon Light Tiles into power outlet.

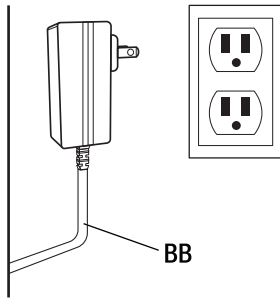

You are now ready to use the smart hexagon light tile. To activate smart features proceed to steps 4 & 5.

4 Pair Your Device

Press and hold the On/Off button on the LED controller (CC) when lights are on for 5 seconds or until it blinks to enter pairing mode.

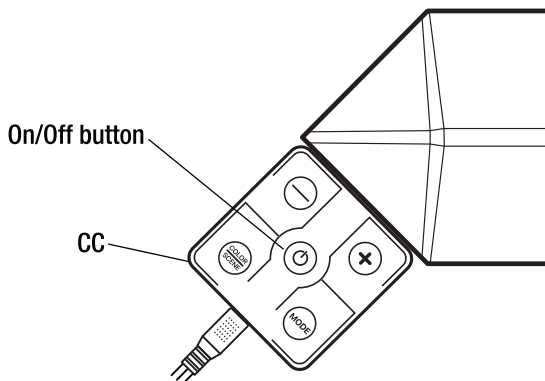

5 Launch the Feit Electric App to Complete the Set Up

Tap Add Device or the + sign, then select smart hexagon light tiles and confirm. You will be prompted to enter your Wi-Fi network and password.



NOTE: Be sure to connect to a 2.4 GHz Wi-Fi network that covers your installation location.

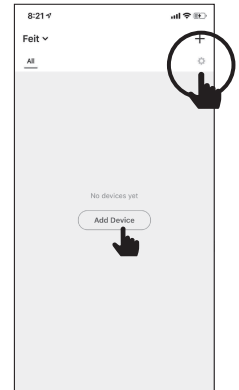

(Optional) Connect to Google Home or Alexa Using the In-App Guide

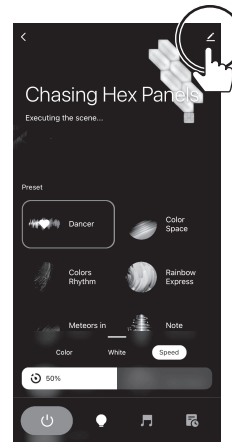

Tap Pen icon

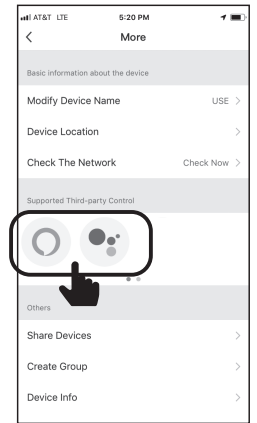

Choose Alexa or Google

Need Help?

Thank you for your purchase
Questions, comments or feedback?
We'd love to hear from you.

Visit feit.com/help for support or connect with us:



@FeitElectric



@FeitElectricInc



feitelectriclighting

