

AXOR

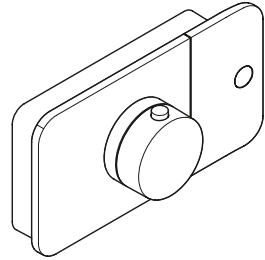

AXOR One®
45711xx1

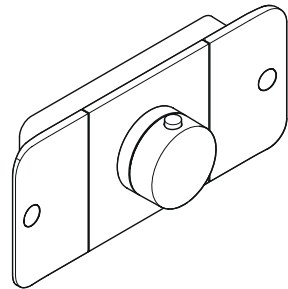

AXOR One®
45712xx1

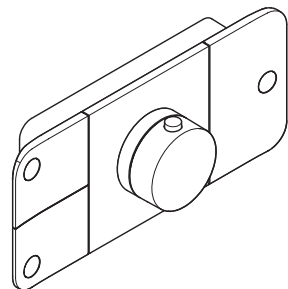

AXOR One®
45713xx1

EN Installation / User Instructions / Warranty
FR Instructions de montage / Mode d'emploi / Garantie
ES Instrucciones de montaje / Manejo / Garantía

INSTALLATION

ENGLISH

TECHNICAL INFORMATION

Water pressure recommended	15 - 75 PSI (0.1-0.5 MPa)
maximum	145 PSI (1 MPa)
Hot water temp. recommended	120°-140° F (49°- 60°C)*
maximum	176°F (80° C)*
Flow rate @ 44 PSI	
45711xx1	5.8 GPM (21.9 L/min)
45712xx1, 45713xx1	1.75 GPM (6.6 L/min)

* Please know and follow all applicable local plumbing codes when setting the temperature on the water heater.

INSTALLATION CONSIDERATIONS

- / For best results, Hansgrohe recommends that this unit be installed by a licensed, professional plumber.
- / Please read over these instructions thoroughly before beginning installation. Make sure that you have all tools and supplies needed to complete the installation.
- / This trim kit is for use with rough valve 45710181.
- / This thermostatic mixing valve is for use with a showerhead rated at 1.1 GPM (4.2 L/min) or higher.
- / This valve is not for use as a tub filler.
- / To prevent scald injury, the maximum output temperature of the shower mixing valve (not included) must be no higher than 120°F (49°C). In Massachusetts, the maximum output temperature can be no higher than 112°F (44°C).
- / Keep this booklet and the receipt (or other proof of date and place of purchase) for this product in a safe place. The receipt is required should it be necessary to request warranty parts.

FRANÇAIS

DONNÉES TECHNIQUES

Pression d'eau recommandée	15 - 75 PSI (0.1-0.5 MPa)
maximum	145 PSI (1 MPa)
Température d'eau chaude recommandée	120°-140° F (49°- 60°C)*
maximum	176°F (80° C)*
Capacité nominale @ 44 PSI	
45711xx1	5.8 GPM (21.9 L/min)
45712xx1, 45713xx1	1.75 GPM (6.6 L/min)

* Vous devez connaître et respecter tous les codes de plomberie locaux applicables pour le réglage de la température du chauffe-eau.

À PRENDRE EN CONSIDÉRATION POUR L'INSTALLATION

- / Pour de meilleurs résultats, Hansgrohe recommande que ce produit soit installé par un plombier professionnel licencié.
- / Veuillez lire attentivement ces instructions avant de procéder à l'installation. Assurez-vous de disposer de tous les outils et du matériel nécessaires pour l'installation.
- / Ce dispositif requiert une pièce intérieure 45710181.
- / Ce mitigeur thermostatique est à utiliser avec des pommes de douches ayant un débit de 1.1 GPM (4.2 L/min) ou supérieur.
- / Ce mitigeur n'est pas destinée à être utilisée comme remplisseur de baignoire.
- / Pour empêcher des blessures par ébullition, la température de sortie maximale du robinet de douche ne doit pas excéder 120°F (49°C). Au Massachusetts, la température de sortie maximale du robinet de douche ne doit pas excéder 112°F (44°C).
- / Conservez ce livret et le reçu (ou une autre preuve sur laquelle figurent la date et l'endroit de l'achat) pour ce produit dans un endroit sûr. Le reçu est requis si vous commandez des pièces sous garantie.

ESPAÑOL

DATOS TECNICOS

Presión en servicio recomendada	15 - 75 PSI (0.1-0.5 MPa)
máximo	145 PSI (1 MPa)
Temperatura del agua caliente recomendada	120°-140° F (49°- 60° C)*
máximo	176° F (80° C)*
Caudal máximo @ 44 PSI	
45711xx1	5.8 GPM (21.9 L/min)
45712xx1, 45713xx1	1.75 GPM (6.6 L/min)

* Debe conocer y cumplir todos los códigos locales aplicables para ajustar la temperatura del calentador de agua.

CONSIDERACIONES PARA LA INSTALACIÓN

- / Para obtener mejores resultados, la instalación debe estar a cargo de un plomero profesional matriculado.
- / Antes de comenzar la instalación, lea estas instrucciones detenidamente. Asegúrese de tener las herramientas y los insumos necesarios para completar la instalación.
- / La unidad requiere una pieza interior de válvula 45710181.
- / El mezclador termostático está diseñado para uso con cabezales de ducha calificados a 1.1 GPM (4.2 L/min) o más.
- / Este mezclador no es para usar como llenadora de bañera.
- / Para evitar escaldaduras, la máxima temperatura de salida de la válvula de la ducha no debe exceder los 120°F (49°C). En Massachusetts, la máxima temperatura de salida de la válvula de la ducha no debe exceder los 112°F (44°C).
- / Mantenga este folleto y el recibo (u otro comprobante del lugar y fecha de compra) de este producto en lugar seguro. El recibo se requiere en caso de ser necesario solicitar piezas bajo garantía.

TOOLS REQUIRED / OUTILS UTILES / HERRAMIENTAS ÚTILES

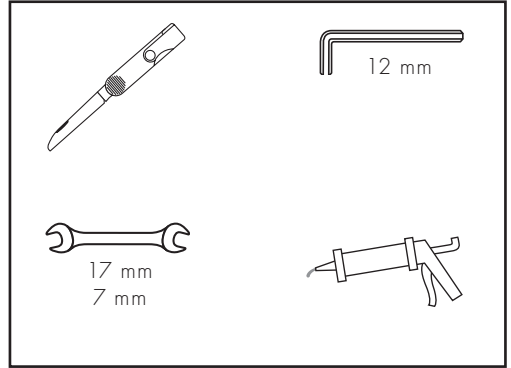

AXOR One
45711xx1

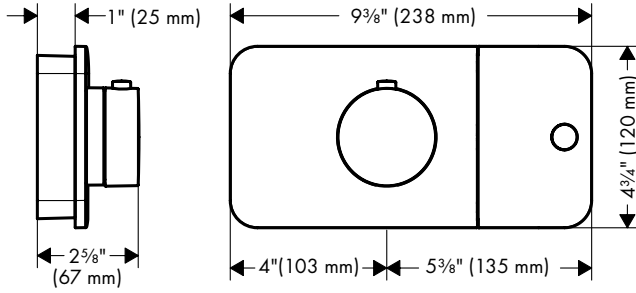

AXOR One
45712xx1

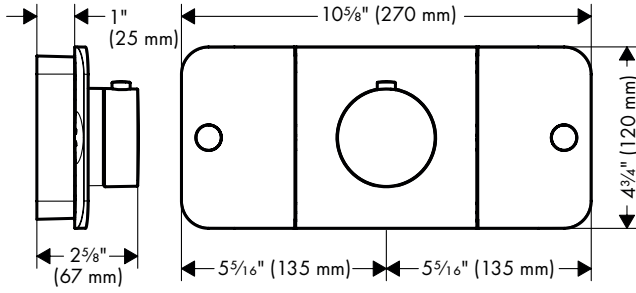

AXOR One
45713xx1

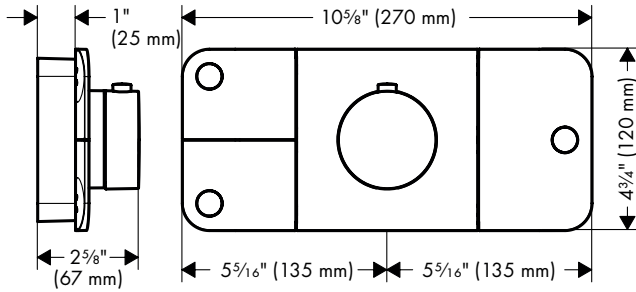

SUGGESTED INSTALLATIONS / SUGGESTIONS D'INSTALLATION /
SUGERENCIAS DE INSTALACIÓN

AXOR One
45711xx1

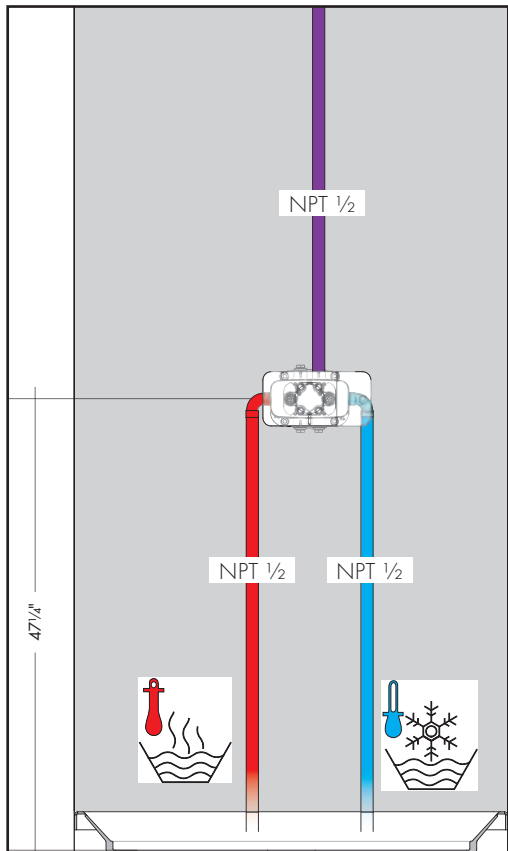

AXOR One
45712xx1

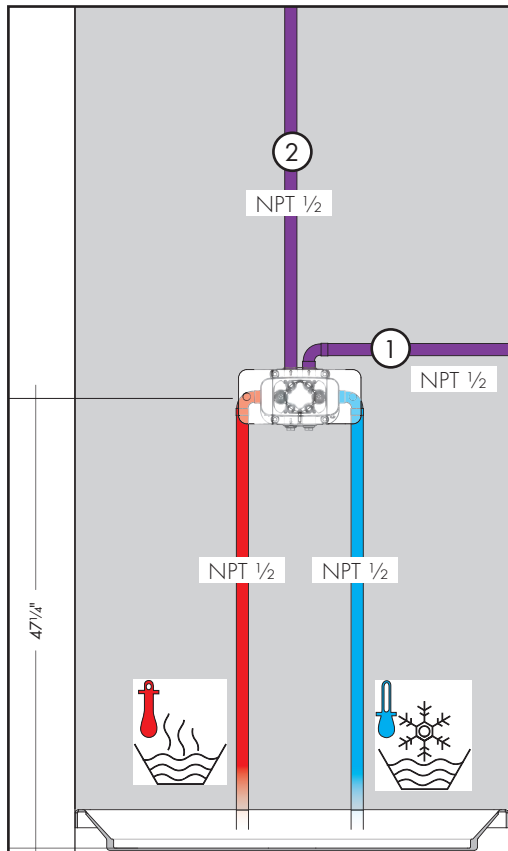

SUGGESTED INSTALLATIONS / SUGGESTIONS D'INSTALLATION /
SUGERENCIAS DE INSTALACIÓN

AXOR One
45713xx1

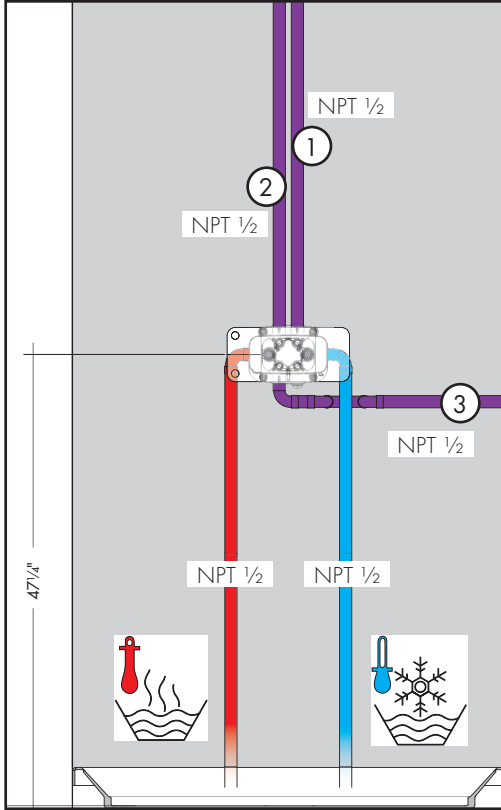

INSTALLATION / INSTALLATION / INSTALACIÓN

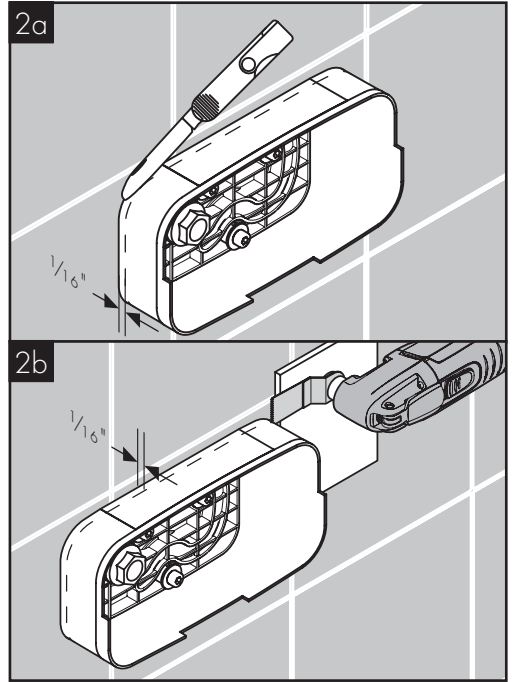
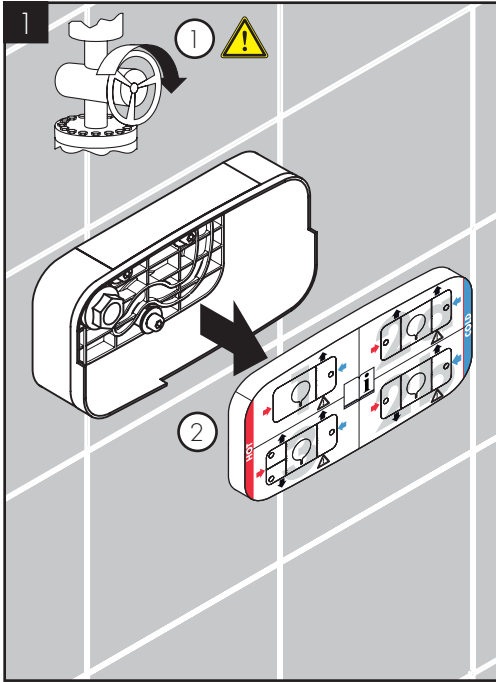

ENGLISH

FRANÇAIS

ESPAÑOL

Turn the water off at the main.

Fermez l'eau à la valve principale.

Cierre el paso del agua en la entrada del suministro.

Remove the dust cover from the plaster shield.

Retirez le pare-poussière du protecteur.

Retire la cubierta antipolvo del protector de yeso.

Cut the plaster shield so that it extends $\frac{1}{16}$ " outside the surface of the finished wall.

Coupez le protecteur de façon à ce qu'une partie de $\frac{1}{16}$ po soit à l'extérieur de la surface du mur fini.

Corte el protector de yeso de modo que sobresalga $\frac{1}{16}$ " de la superficie de la pared terminada.

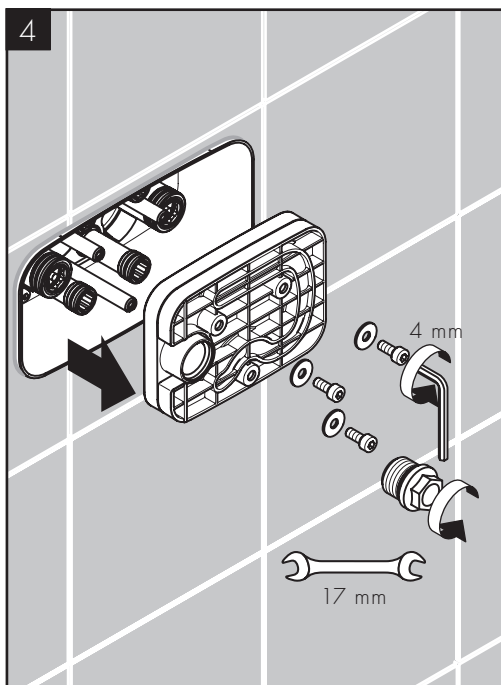
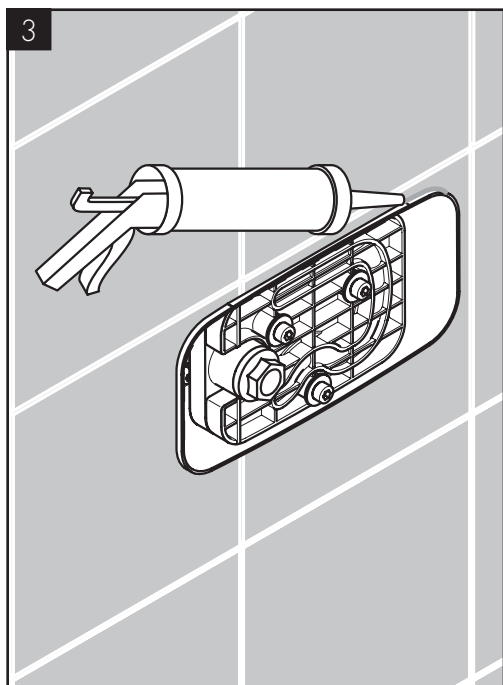

ENGLISH

FRANÇAIS

ESPAÑOL

⚠ Seal the wall around the plaster shield using waterproof sealant.

⚠ Scellez le mur autour du protecteur à l'aide d'un agent d'étanchéité.

⚠ Selle la pared alrededor del protector de yeso con un sellador impermeable.

Remove the plug and the flush insert.

Retirez le bouchon et l'insert de rinçage.

Retire el conector y el inserto de lavado.

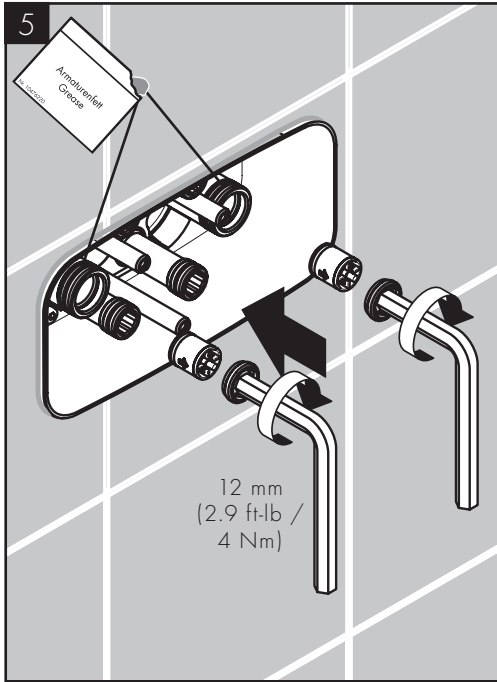

ENGLISH

Remove the check valve covers.

Insert the check valves.

Install the check valve covers.

Lightly lubricate the o-rings using white plumber's grease.

FRANÇAIS

Retirez les caches des clapets anti-retour.

Insérer les clapets anti-retour.

Mettez les caches des clapets anti-retour.

Lubrifiez légèrement les joints toriques en utilisant de la graisse de plomberie blanche.

ESPAÑOL

Retire las tapas de la válvula de retención.

Inserte las válvulas de retención.

Instale las tapas de la válvula de retención.

Lubrique ligeramente los retenes anulares con grasa blanca para plomería.

45711XX1 → PAGE / PÁGINA 10

45712XX1 → PAGE / PÁGINA 14

45713XX1 → PAGE / PÁGINA 19

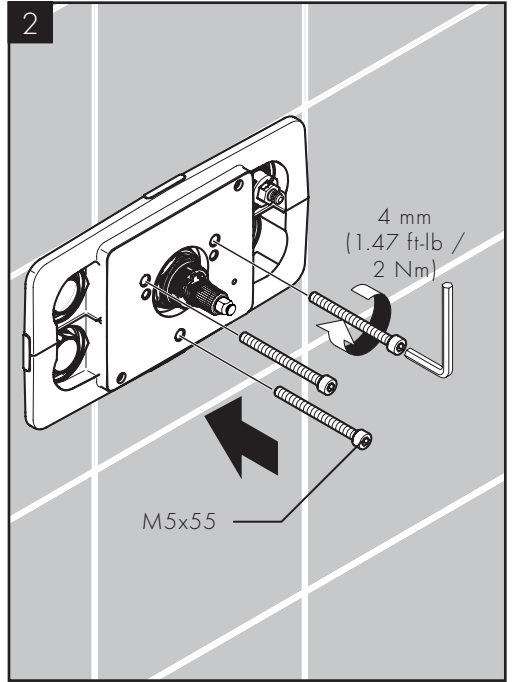
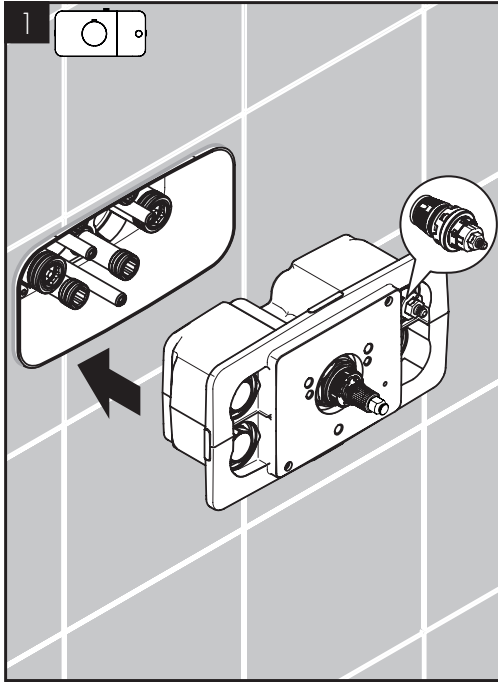

ENGLISH

FRANÇAIS

ESPAÑOL

Insert the function block into the rough.

Insérez le bloc de fonction dans la pièce intérieure.

Inserte el bloque de función en la pieza interior.

Install the M5x55 screws.

Installez les vis M5x55.

Instale los tornillos M5x55.

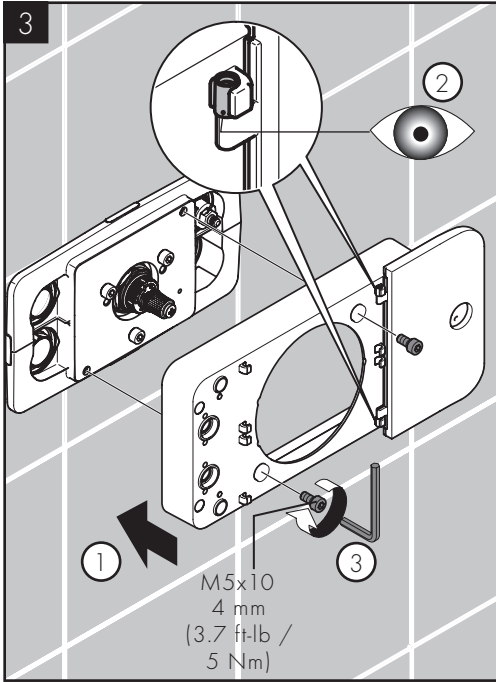

ENGLISH

Install the control panel.

Install the M5x10 screws.

Position the escutcheon over the control panel.

Install the escutcheon using the M5x25 screws.

FRANÇAIS

Installez le tableau de commande.

Installez les vis M5x10.

Placez la rosace sur le tableau de commande.

Installez la rosace à l'aide des vis M5x25.

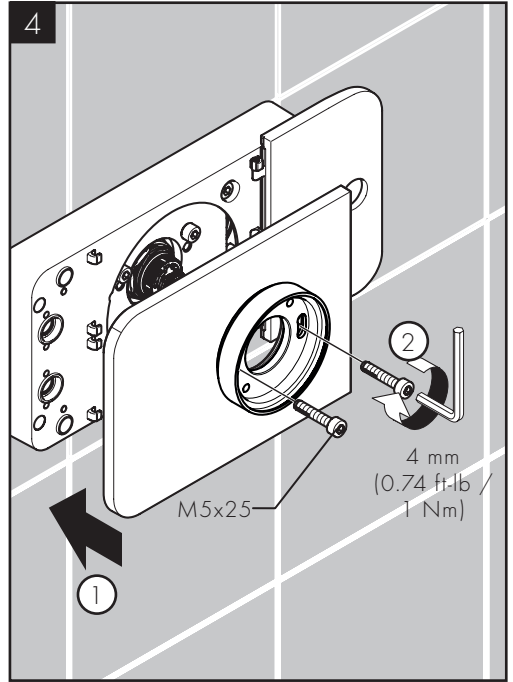

ESPAÑOL

Instale el panel de control.

Instale los tornillos M5x10.

Coloque el escudo sobre el panel de control.

Instale el escudo usando tornillos M5x25.

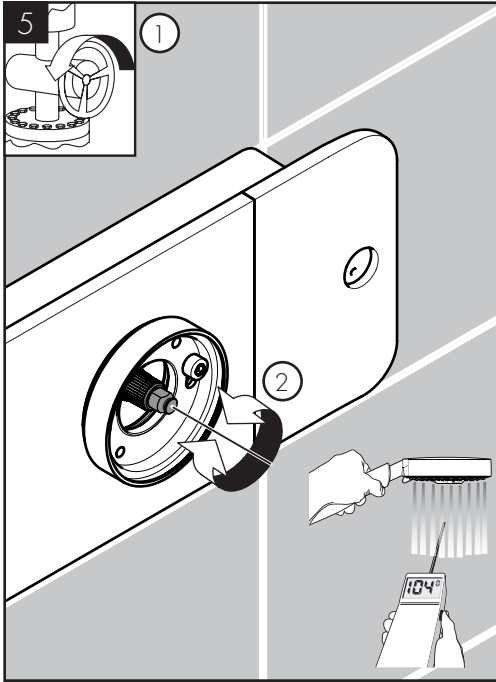

ENGLISH

Turn the water on at the main.

Rotate the thermostatic cartridge stem until the output water is 104°F (40 °C).

Install the sleeve so that it is oriented as shown in the diagram.

FRANÇAIS

Ouvrez l'eau à la valve principale.

Tournez la tige de la cartouche thermostatique jusqu'à ce que l'eau qui s'écoule atteigne 40 °C (104°F).

Installez la douille de façon à ce qu'elle soit orientée comme sur le schéma.

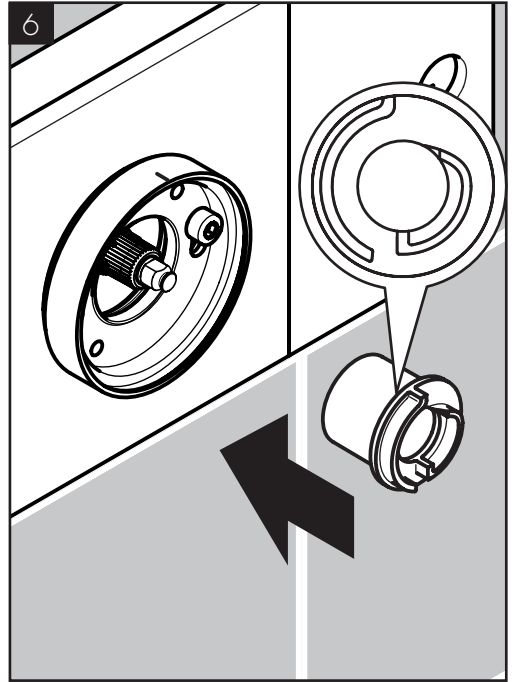

ESPAÑOL

Abra el paso del agua en la entrada del suministro.

Gire el vástago del cartucho termostático hasta que el agua de salida esté en 40 °C (104°F).

Instale el manguito de manera que quede orientado como se muestra en el dibujo.

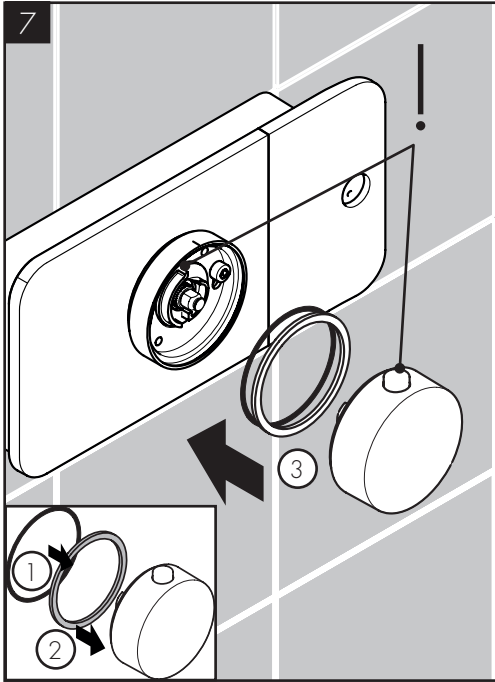

ENGLISH

Install the handle so that the safety stop override button is aligned with the notch on the top of the sleeve.

Tighten the handle screw fully, then loosen by one full turn.

Install the screw cover.

Install the appropriate icon.

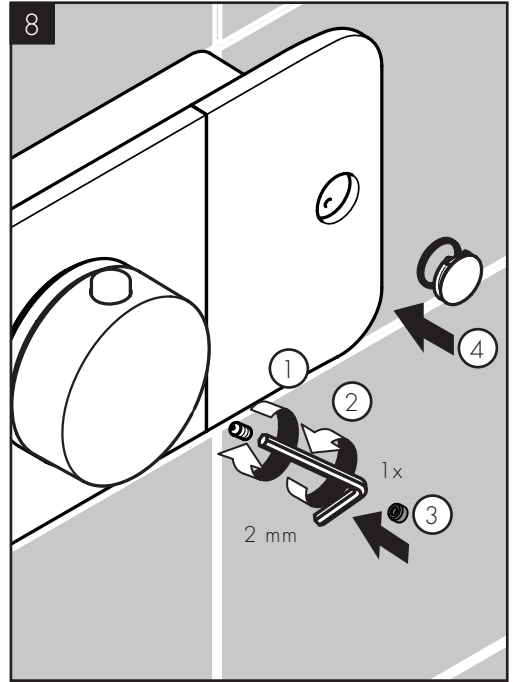

FRANÇAIS

Installez la poignée de sorte que le bouton de surpassement de la butée de sécurité soit aligné avec l'encoche qui se trouve sur la partie supérieure de la poignée.

Serrez la vis de la poignée complètement, puis déserez la vis d'un tour complet.

Installez le cache-vis.

Placez le symbole qui convient.

ESPAÑOL

Instale la manija de forma que el botón de vencimiento de tope de seguridad esté alineado con la ranura en la parte superior del manguito.

Apriete el tornillo de la manija completamente, y luego afloje el tornillo una vuelta completa.

Instale la tapa del tornillo.

Instale los símbolo apropiado.

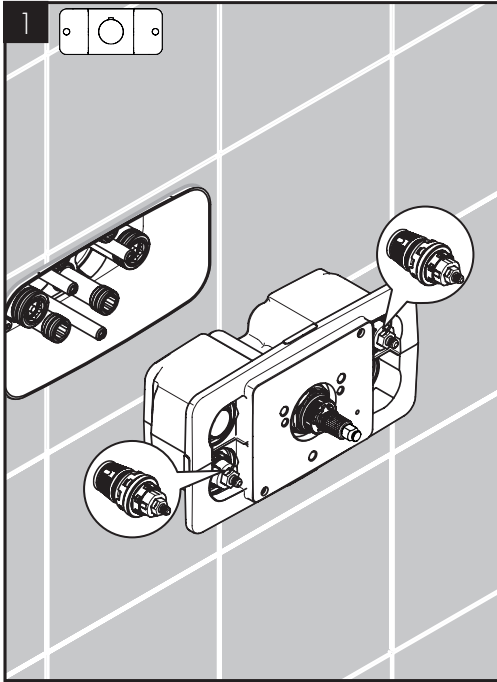

ENGLISH

Insert the function block in the rough.

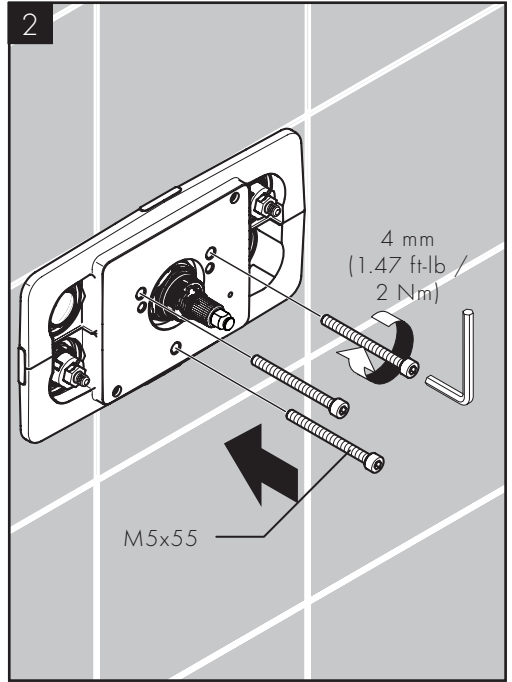

ESPAÑOL

Inserte el bloque de función en la pieza interior.

Install the M5x55 screws.

Installez les vis M5x55.

Instale los tornillos M5x55.

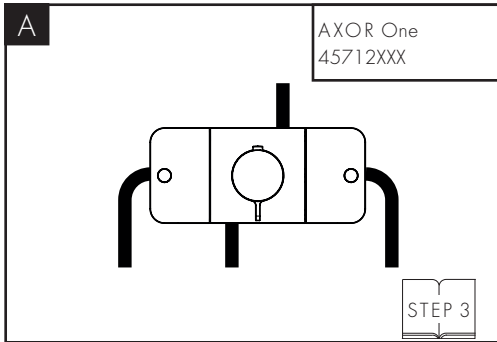

ENGLISH

A. If using the top and bottom ports, proceed to step 3.

B. If using both top ports, first exchange the position of the cartridge on the left (Step B1 and B2). Proceed to step 3.

FRANÇAIS

A. Si vous utilisez les ports supérieur et inférieur, passez à l'étape 3.

B. Si vous utilisez les deux ports supérieurs, changez d'abord la position de la cartouche sur la gauche (étapes B1 et B2). Passez à l'étape 3.

ESPAÑOL

A. Si usa los puertos superior e inferior, continúe con el paso 3.

B. Si usa ambos puertos superiores, primero cambie la posición del cartucho a la izquierda (Paso B1 y B2). Continúe con el paso 3.

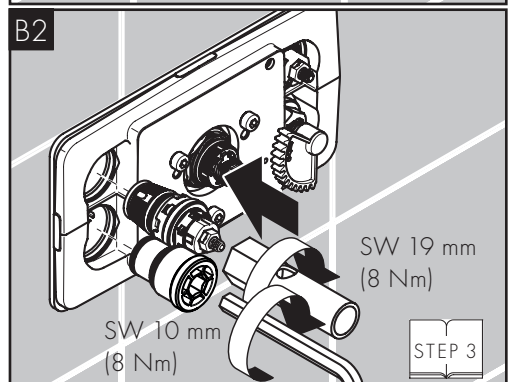
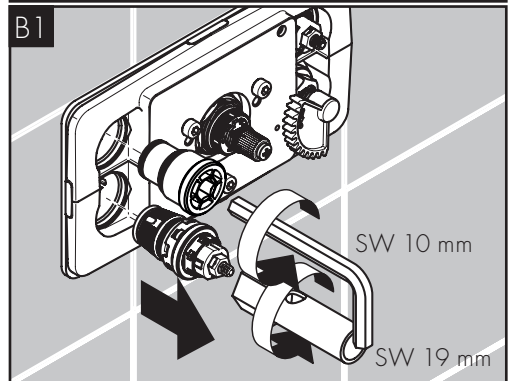
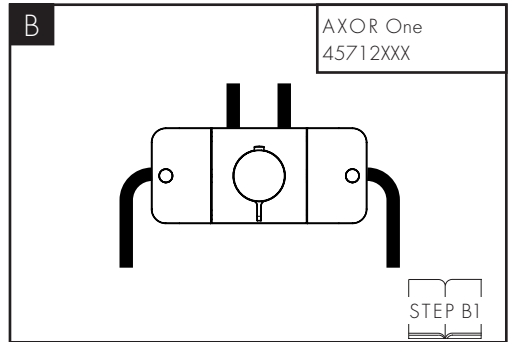

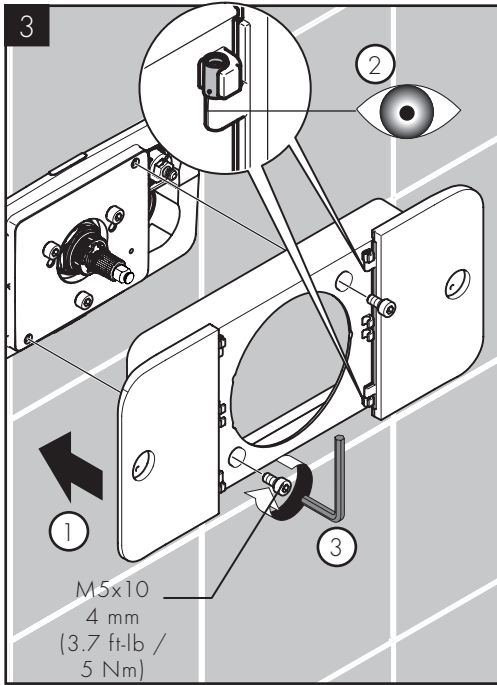

ENGLISH

Install the control panel.

Install the M5x10 screws.

Position the escutcheon over the control panel.

Install the escutcheon using the M5x25 screws.

FRANÇAIS

Installez le tableau de commande.

Installez les vis M5x10.

Placez la rosace sur le tableau de commande.

Installez la rosace à l'aide des vis M5x25.

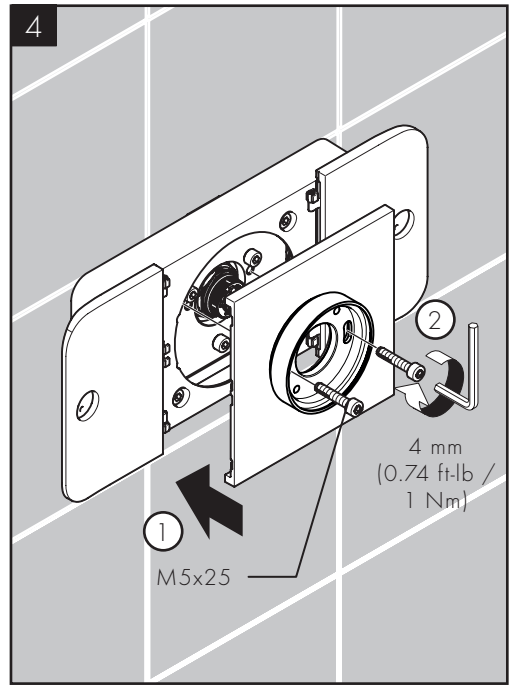

ESPAÑOL

Instale el panel de control.

Instale los tornillos M5x10.

Coloque el escudo sobre el panel de control.

Instale el escudo usando tornillos M5x25.

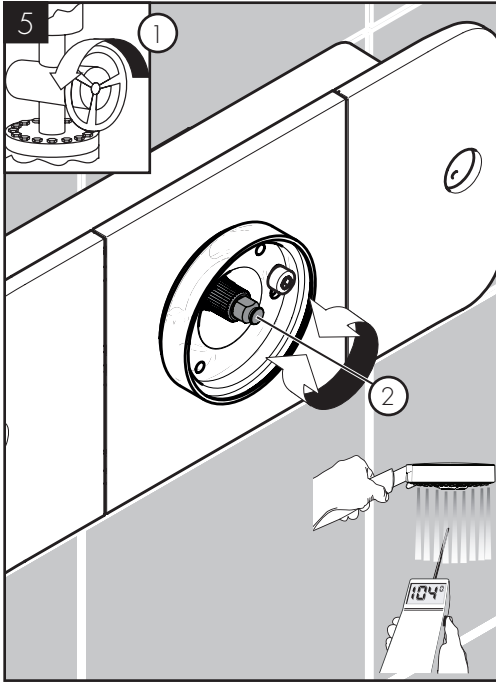

ENGLISH

Turn the water on at the main.

Rotate the thermostatic cartridge stem until the output water is 104°F (40 °C).

Install the sleeve so that it is oriented as shown in the diagram.

FRANÇAIS

Ouvrez l'eau à la valve principale.

Tournez la tige de la cartouche thermostatique jusqu'à ce que l'eau qui s'écoule atteigne 40 °C (104°F).

Installez la douille de façon à ce qu'elle soit orientée comme sur le schéma.

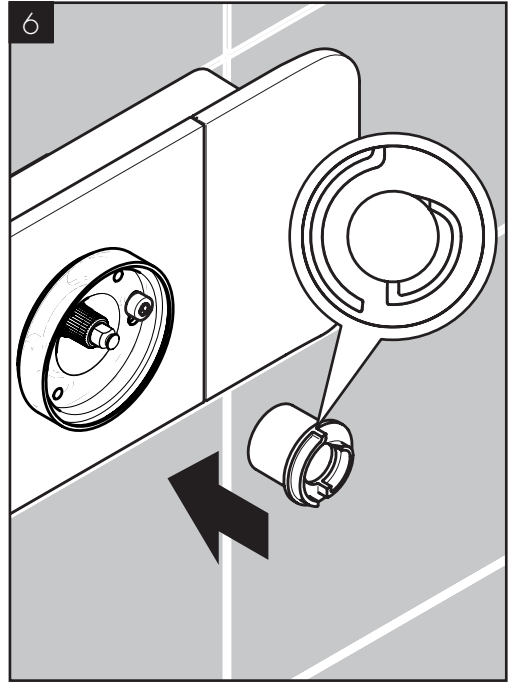

ESPAÑOL

Abra el paso del agua en la entrada del suministro.

Gire el vástago del cartucho termostático hasta que el agua de salida esté en 40 °C (104°F).

Instale el manguito de manera que quede orientado como se muestra en el dibujo.

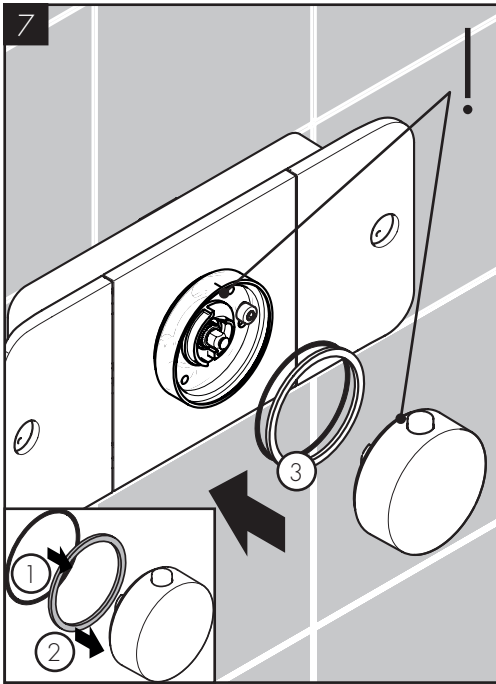

ENGLISH

Install the handle so that the safety stop override button is aligned with the notch on the top of the sleeve.

Tighten the handle screw fully, then loosen by one full turn.

Install the screw cover.

Install the appropriate icons.

FRANÇAIS

Installez la poignée de sorte que le bouton de surpassement de la butée de sécurité soit aligné avec l'encoche qui se trouve sur la partie supérieure de la poignée.

Serrez la vis de la poignée complètement, puis desserrez la vis d'un tour complet.

Installez le cache-vis.

Placez les symboles appropriés.

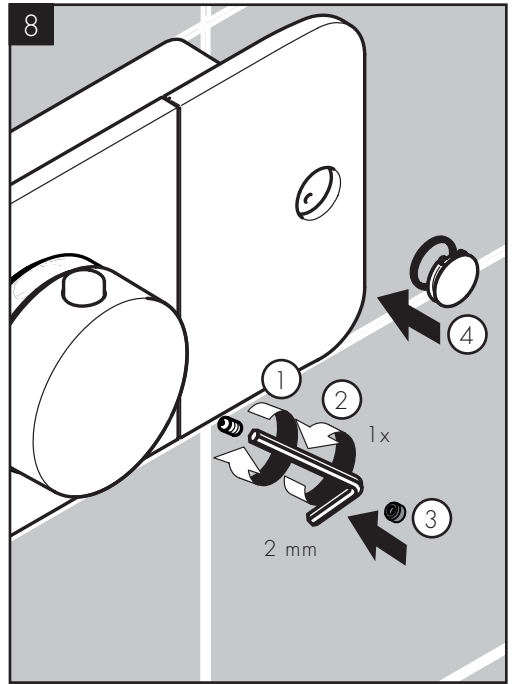

ESPAÑOL

Instale la manija de forma que el botón de vencimiento de tope de seguridad esté alineado con la ranura en la parte superior del manguito.

Apriete el tornillo de la manija completamente, y luego afloje el tornillo una vuelta completa.

Instale la tapa del tornillo.

Instale los símbolos apropiados.

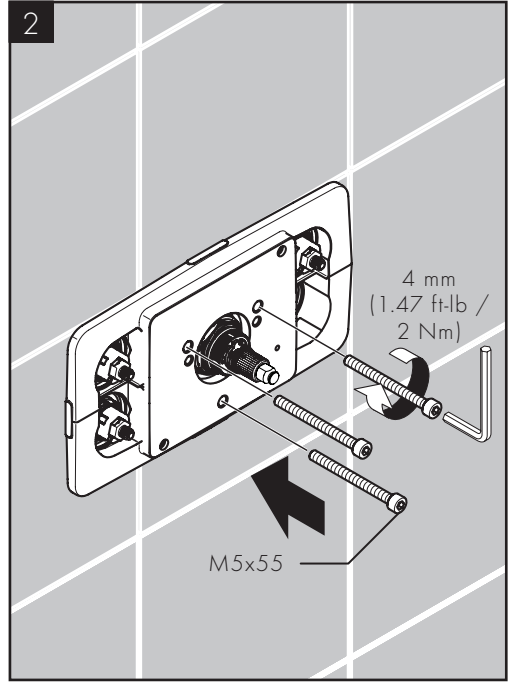
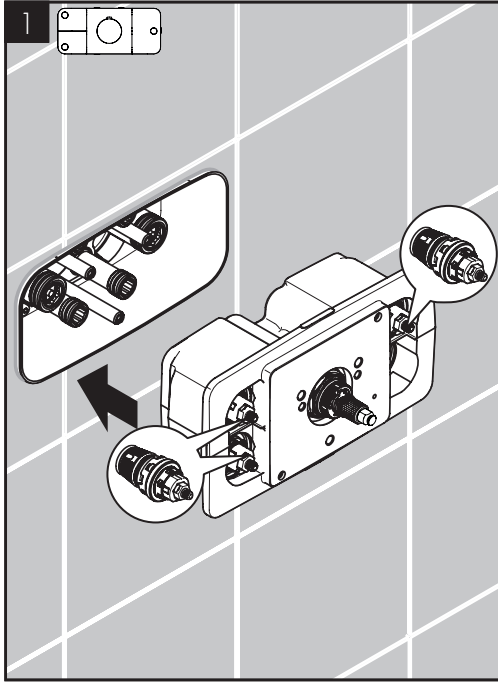

ENGLISH

FRANÇAIS

ESPAÑOL

Insert the function block in the rough.

Insérez le bloc de fonction dans la pièce intérieure.

Inserte el bloque de función en la pieza interior.

Install the M5x55 screws.

Installez les vis M5x55.

Instale los tornillos M5x55.

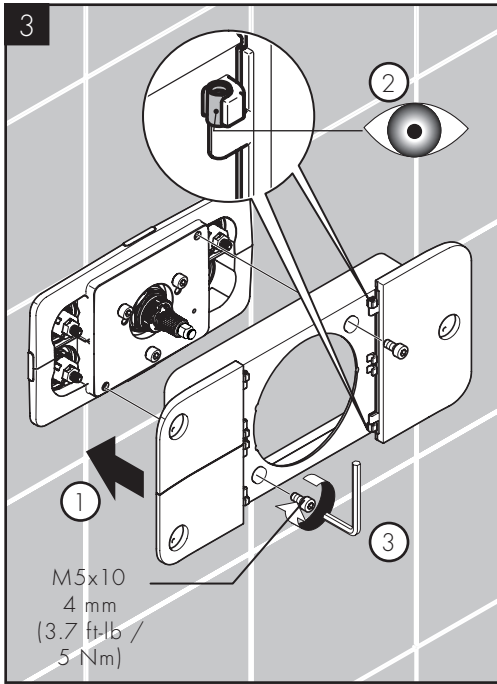

ENGLISH

Install the control panel.

Install the M5x10 screws.

Position the escutcheon over the control panel.

Install the escutcheon using the M5x25 screws.

FRANÇAIS

Installez le tableau de commande.

Installez les vis M5x10.

Placez la rosace sur le tableau de commande.

Installez la rosace à l'aide des vis M5x25.

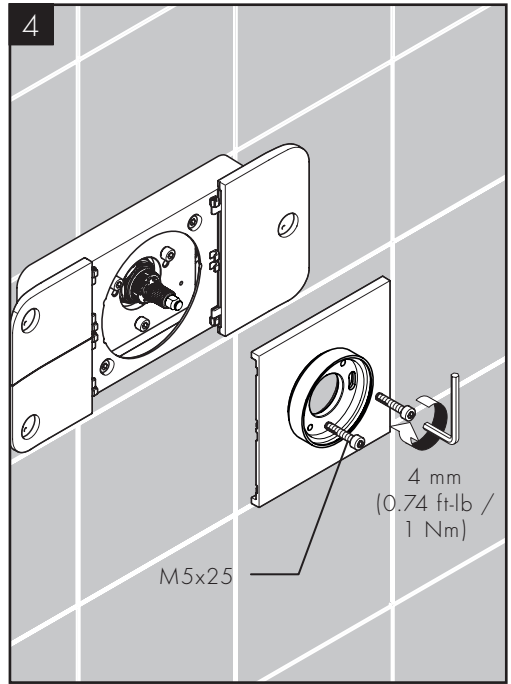

ESPAÑOL

Instale el panel de control.

Instale los tornillos M5x10.

Coloque el escudo sobre el panel de control.

Instale el escudo usando tornillos M5x25.

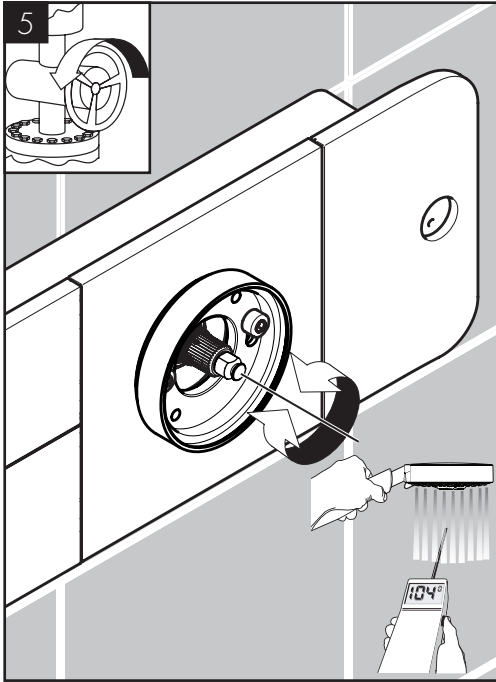

ENGLISH

Turn the water on at the main.

Rotate the thermostatic cartridge stem until the output water is 104°F (40 °C).

Install the sleeve so that it is oriented as shown in the diagram.

FRANÇAIS

Ouvrez l'eau à la valve principale.

Tournez la tige de la cartouche thermostatique jusqu'à ce que l'eau qui s'écoule atteigne 40 °C (104°F).

Installez la douille de façon à ce qu'elle soit orientée comme sur le schéma.

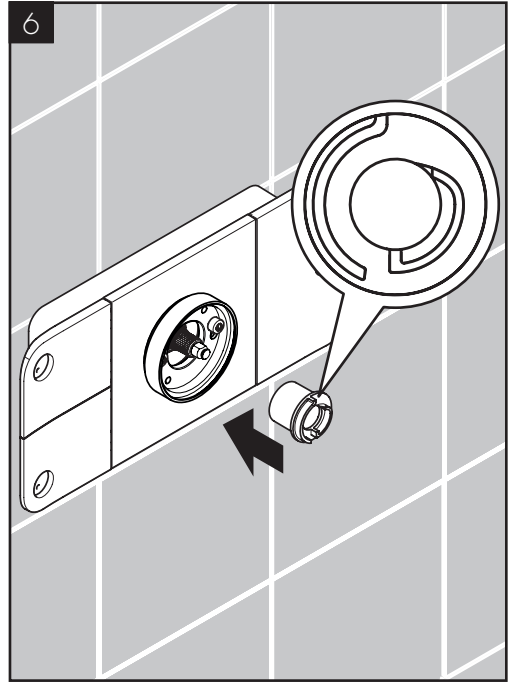

ESPAÑOL

Abra el paso del agua en la entrada del suministro.

Gire el vástago del cartucho termostático hasta que el agua de salida esté en 40 °C (104°F).

Instale el manguito de manera que quede orientado como se muestra en el dibujo.

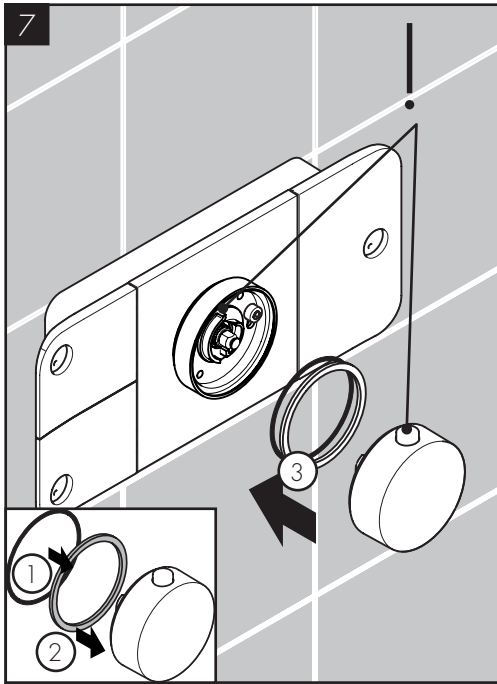

ENGLISH

Install the handle so that the safety stop override button is aligned with the notch on the top of the sleeve.

Tighten the handle screw fully, then loosen by one full turn.

Install the screw cover.

Install the appropriate icons.

FRANÇAIS

Installez la poignée de sorte que le bouton de surpassement de la butée de sécurité soit aligné avec l'encoche qui se trouve sur la partie supérieure de la poignée.

Serrez la vis de la poignée complètement, puis déserrez la vis d'un tour complet.

Installez le cache-vis.

Placez les symboles appropriés.

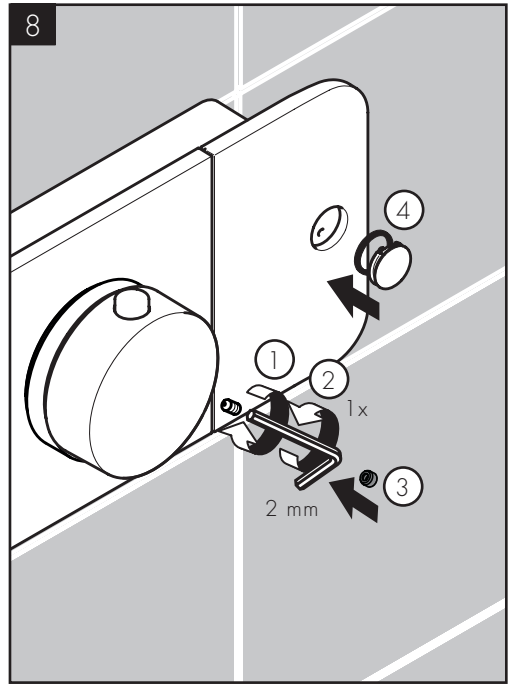

ESPAÑOL

Instale la manija de forma que el botón de vencimiento de tope de seguridad esté alineado con la ranura en la parte superior del manguito.

Apriete el tornillo de la manija completamente, y luego afloje el tornillo una vuelta completa.

Instale la tapa del tornillo.

Instale los símbolos apropiados.

SET THE HIGH TEMPERATURE LIMIT STOP, JUSTIFY THE HANDLE / RÉGLER LA BUTÉE DE LIMITE D'EAU CHAUDE, RÉGLER LA POIGNÉE / FIJE EL TOPE DE LÍMITE DE ALTA TEMPERATURA, AJUSTE LA MANIJA

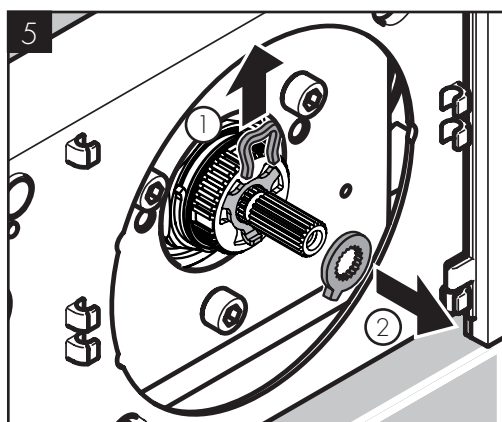
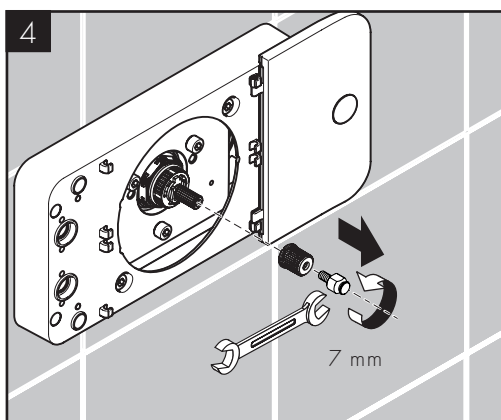
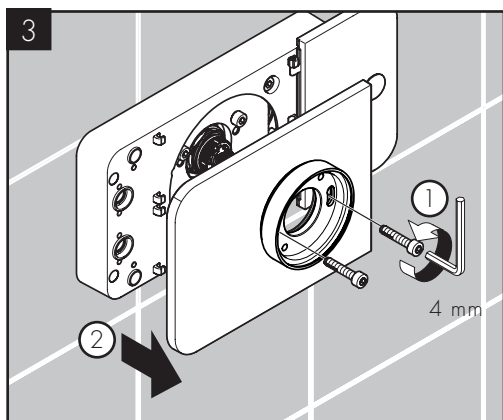
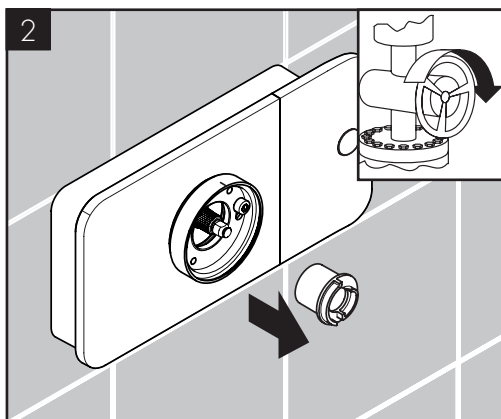
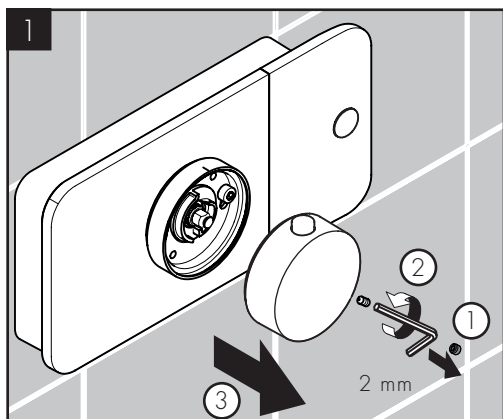

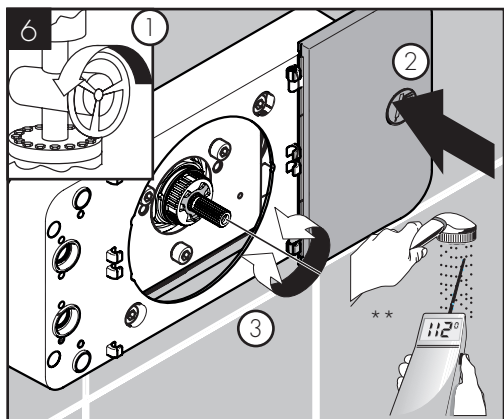

**Follow all applicable local plumbing codes when setting the high temperature limit stop. To prevent scald injury, the maximum output temperature of the shower valve must be no higher than 120°F (49°C). In Massachusetts, the maximum output temperature can be no higher than 112°F (44°C).

**Pour empêcher des blessures par ébullantement, la température de sortie maximale du robinet de douche ne doit pas excéder 120°F (49°C). Au Massachusetts, la température de sortie maximale du robinet de douche ne doit pas excéder 112°F (44°C).

**Al prevenir escaldada herida, la temperatura de salida máxima de la válvula de chaparrón no debe ser más alto que 120°F (49°C). En Massachusetts: la temperatura de salida máxima de la válvula no puede ser más alto que 112°F (44°C).

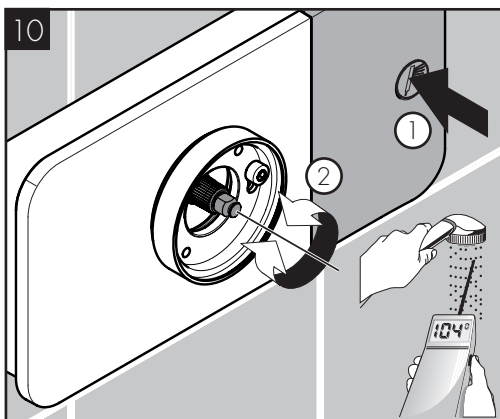
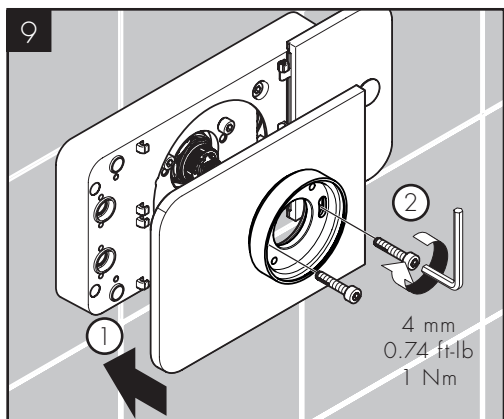
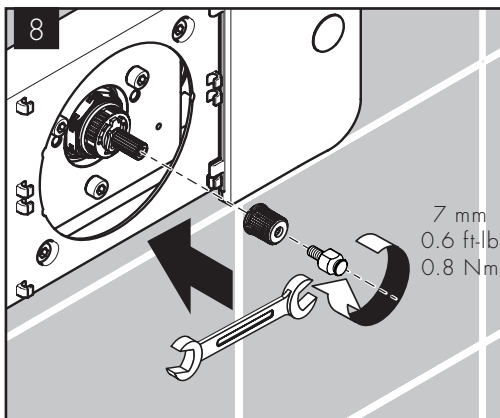
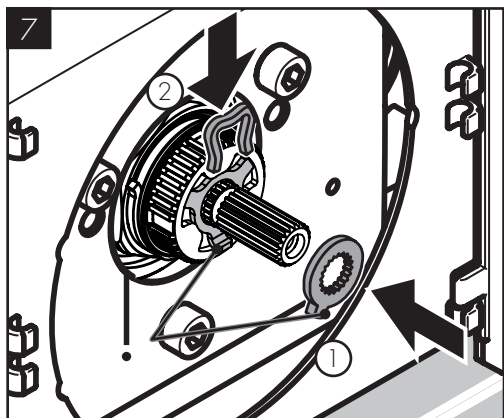

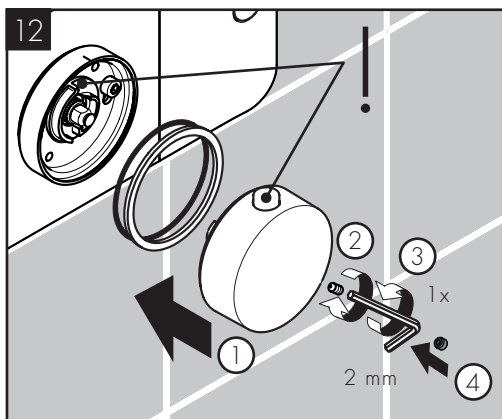
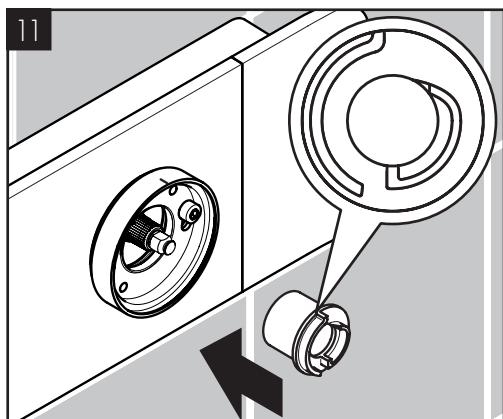

JUSTIFY THE HANDLE / RÉGLEZ LA POIGNÉE / AJUSTE LA MANIJA

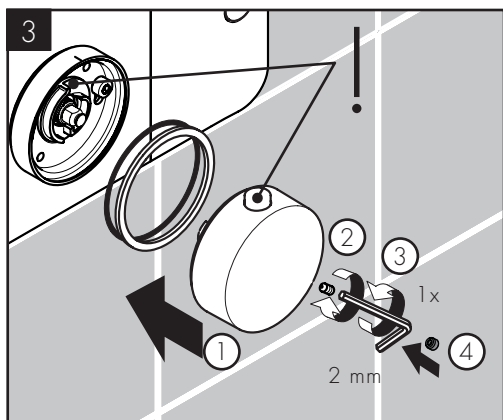
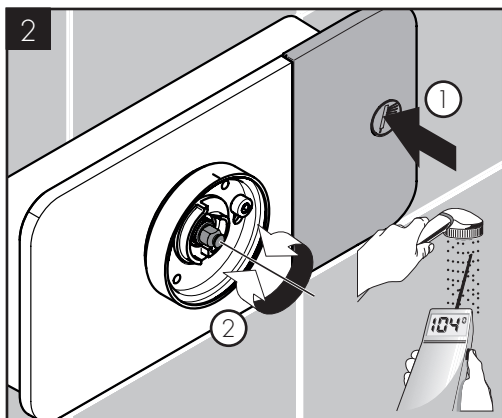
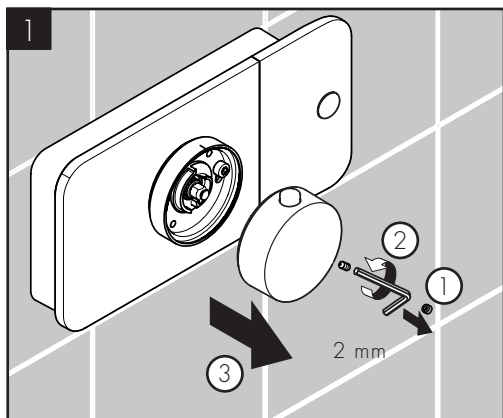

REPLACEMENT PARTS / PIÈCES DÉTACHÉES / REPUESTOS

AXOR One
45711xx1

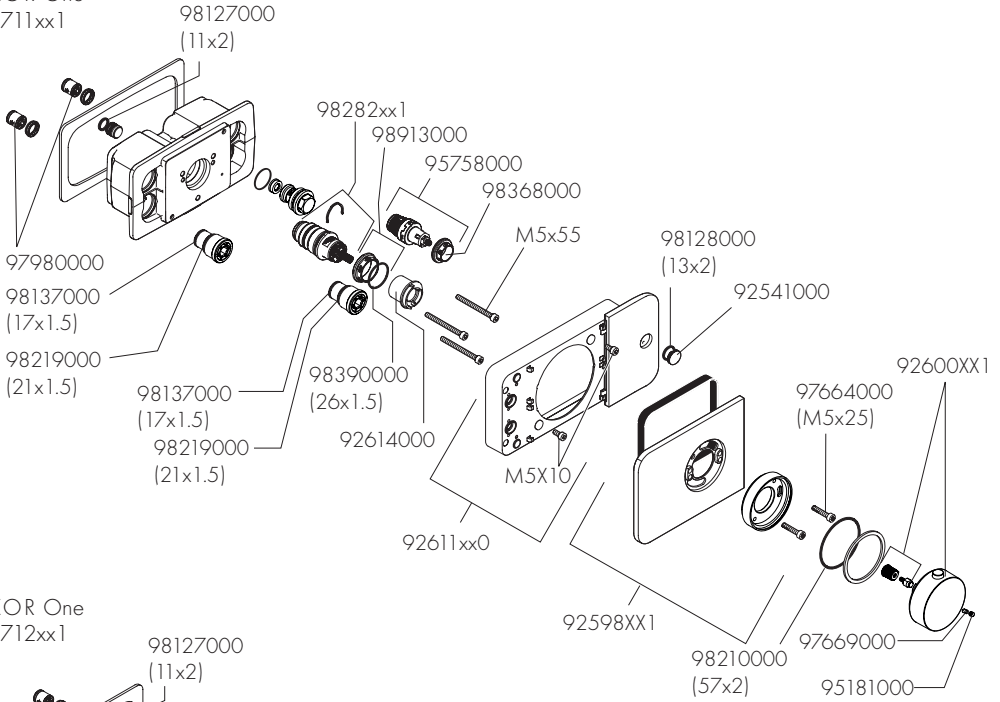

AXOR One
45712xx1

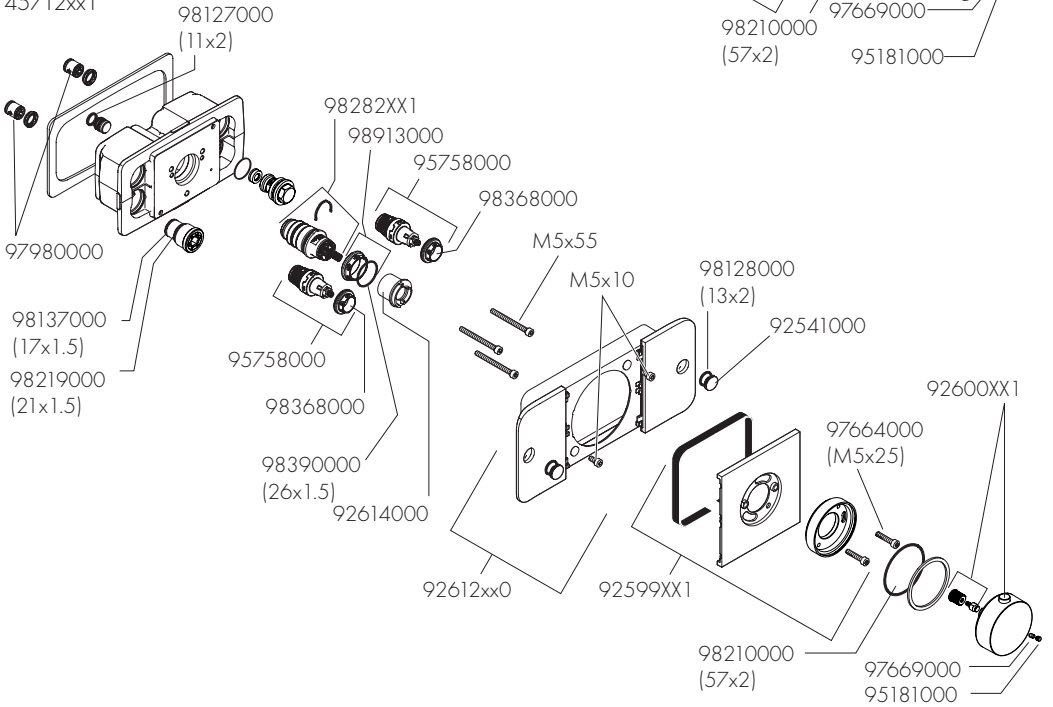

AXOR One
45713xx1

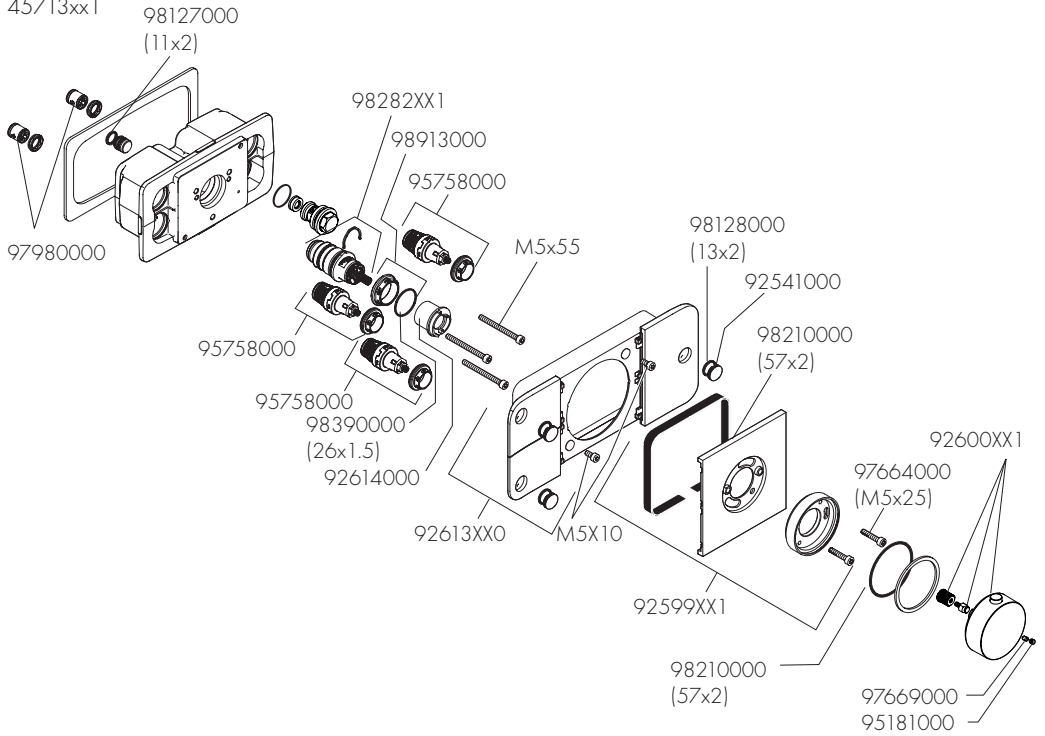

XX = COLORS / COULEURS / ACABADOS

00 = Chrome

25 = Brushed Gold Optik

34 = Brushed Black Chrome

82 = Brushed Nickel

USER INSTRUCTIONS / INSTRUCTIONS DE SERVICE / MANEJO

on
ouvert
abierto

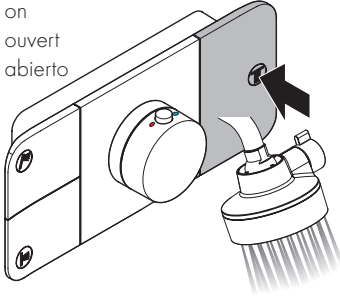

off
fermé
cerrar

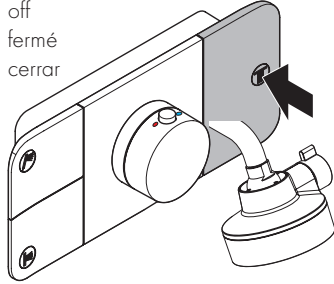

on
ouvert
abierto

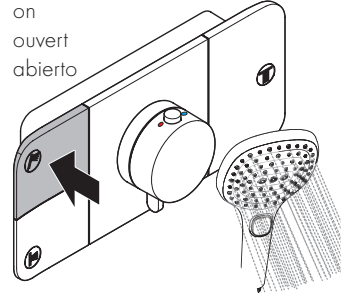

off
fermé
cerrar

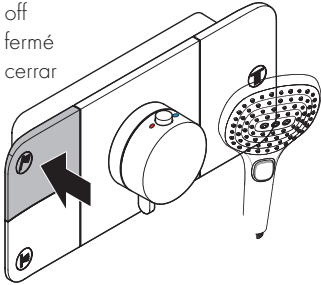

on
ouvert
abierto

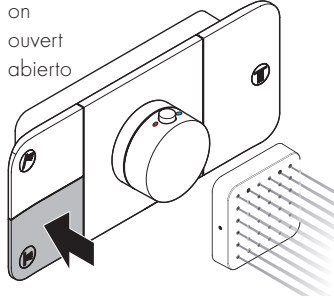

off
fermé
cerrar

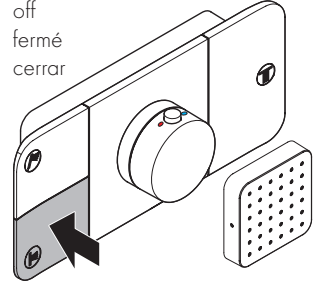

hot
chaud
caliente

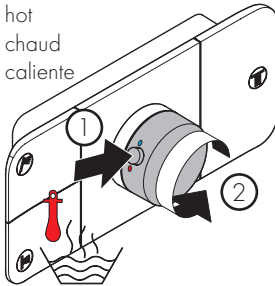

cold
froid
frío

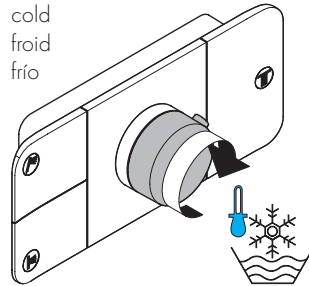

CHECK VALVE MAINTENANCE / ENTRETIEN DE LES CLAPETS ANTI-RETOUR/ MANTENIMIENTO DE LAS VÁLVULAS ANTIRRETORNOS

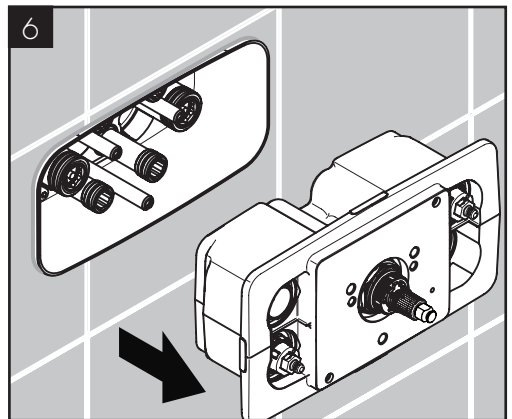
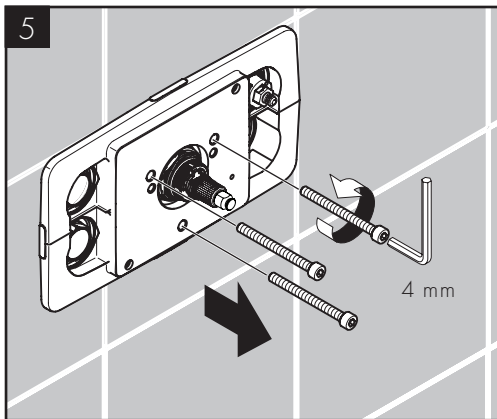
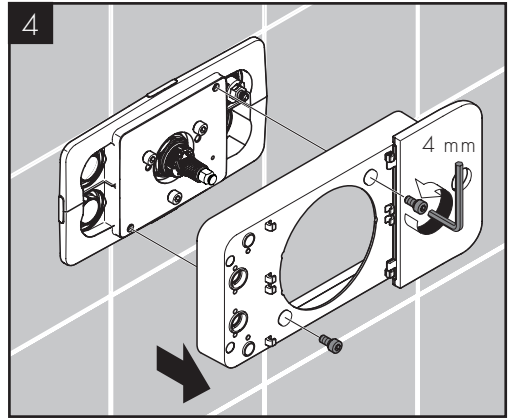
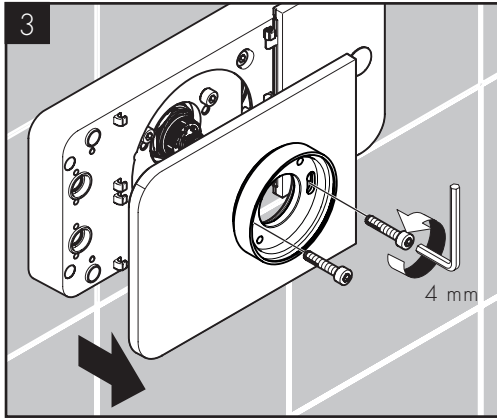
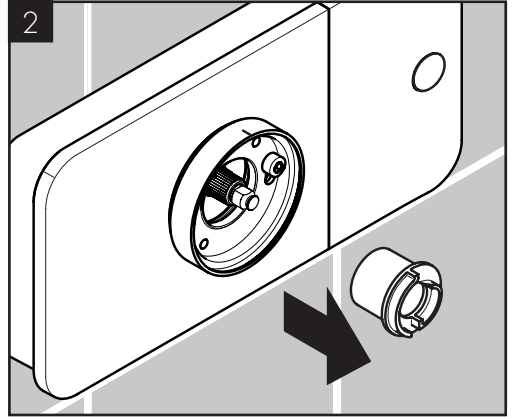
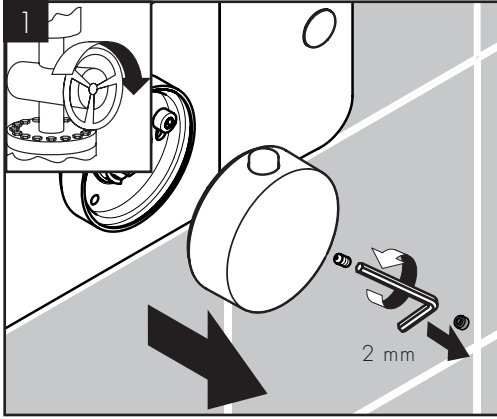

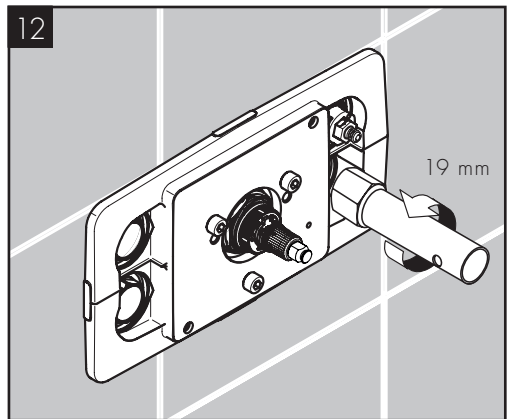
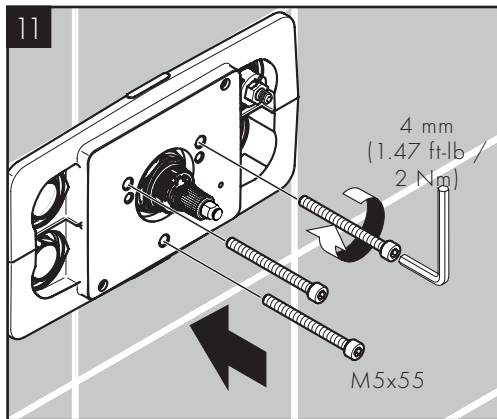
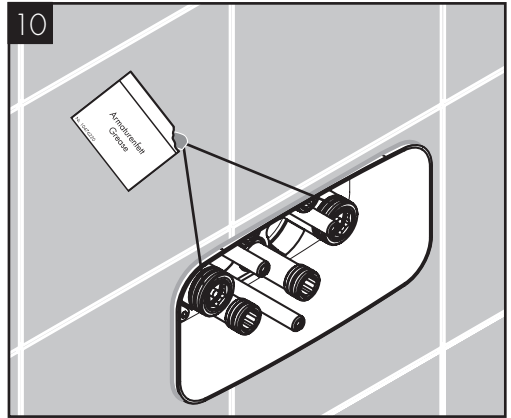
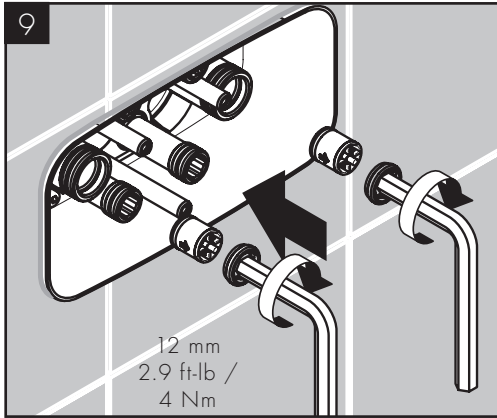
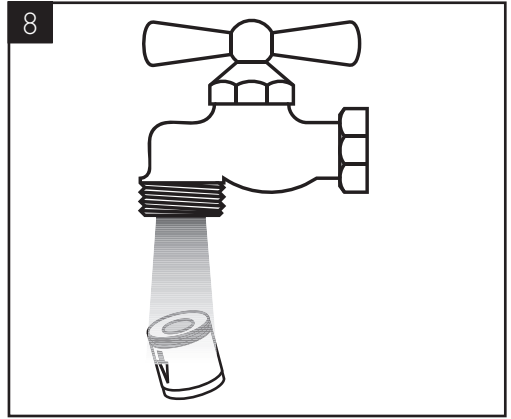
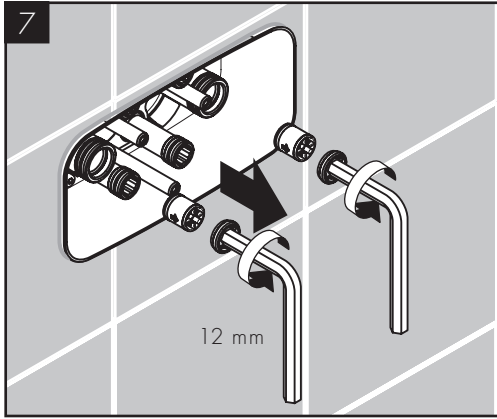

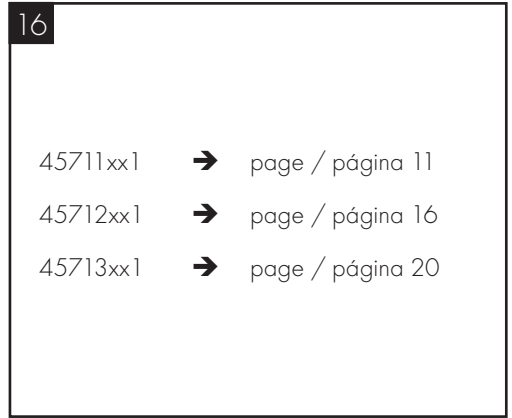
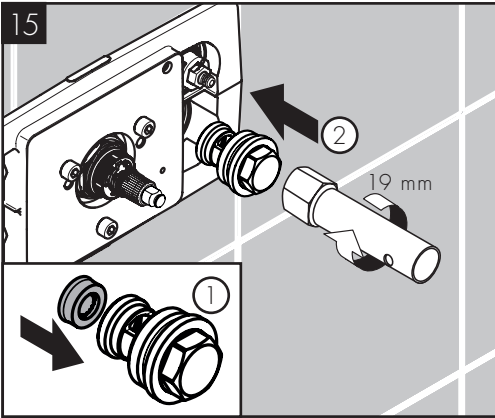
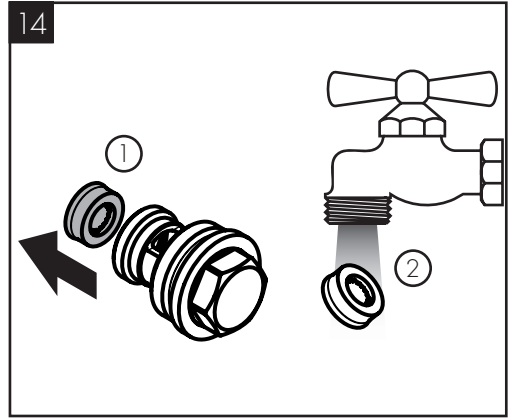
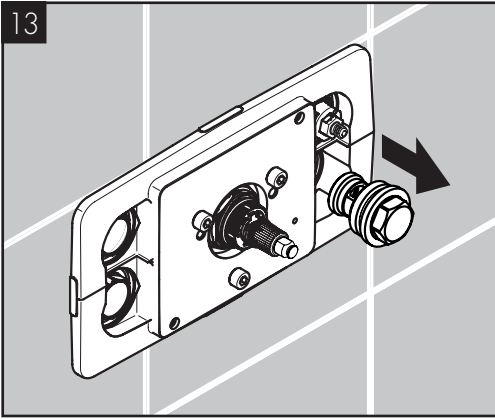

TROUBLESHOOTING

FAULT	CAUSE	REMEDY
Insufficient water	– Supply pressure inadequate	– Check water pressure (If a pump has been installed check to see if the pump is working).
	– Regulator filter dirty	– Clean filter in front of the mixer and on the thermostat cartridge
	– Shower filter seal dirty	– Clean filter seal between shower and hose
Crossflow, hot water being forced into cold water pipe, or vice versa, when mixer is closed	– Backflow preventers dirty or leaking	– Clean backflow preventers, replace if necessary - see page 29
Spout temperature does not correspond with temperature set	– Handle not justified	– Justify the handle - see page 25
	– Hot water temperature too low	– Increase hot water temperature to 120 °F (49 °C) to 140 °F (60 °C)
Temperature regulation not possible	– Thermo cartridge calcified	– Replace thermo cartridge
Instantaneous heater didn't work with thermostat	– Filters are dirty	– Clean the filter / replace filter
	– check valve hasn't moved back	– Replace check valves

DÉPANNAGE

DYSFONCTIONNEMENT	ORIGINE	SOLUTION
Pas assez d'eau	– Pression d'alimentation insuffisante	– Contrôler la pression
	– Filtre de l'élément thermostatique encrassé	– Nettoyer les filtres devant le mitigeur thermostatique et sur la cartouche
	– Joint-filtre de douchette encrassé	– Nettoyer le joint-filtre entre la douchette et le flexible
Circulation opposée, l'eau chaude est comprimée dans l'arrivée d'eau froide et vice versa avec robinet fermé	– Clapet anti-retour encrassé ou défectueux	– Nettoyer le clapet anti-retour ou le changer éventuellement - ver page 29
La température à la sortie ne correspond pas à la température de réglage	– Le thermostat n'a pas été réglé	– Régler le thermostat - ver page 25
	– Température d'eau chaude trop basse, pas d'eau froide	– Augmenter la température d'eau chaude entre 120 °F (49 °C) et 140 °F (60 °C)
Le réglage de la température n'est pas possible	– Cartouche thermostatique entartrée	– Changer la cartouche thermostatique
Le chauffe-eau instantané ne s'allume pas lors de l'utilisation du thermostat	– Filtres encrassés	– Nettoyez / changez les filtres
	– Clapet anti-retour bloque	– Changez le clapet antiretour

LOCALIZACIÓN DE FALLAS

PROBLEMA	CAUSA	SOLUCIÓN
Sale poca agua	- Presión insuficiente	- Comprobar presión
	- Filtro del termoelemento sucio	- Limpiar filtros en las uniones a las tomas de agua caliente y fría y en el cartucho termostático
	- Filtro de la teleducha sucio	- Limpiar / Cambiar filtro entre flexo y teleducha
Flujo de agua cruzada agua caliente entra en la tubería del agua fría o al revés	- Válvula antirretorno sucia o pierde	- Limpiar / cambiar válvula anti-retorno Consulte la página 29.
Temperatura del agua no corresponde a lo marcado	- Termostato no ha sido ajustado	- Ajustar termostato - Consulte la página 25.
	- Temperatura del agua caliente demasiado baja	- Aumentar temperatura del agua caliente a 120 °F (49 °C) - 140 °F (60 °C).
No es posible regular la temperatura	- Termoelemento calcificado o desgastado	- Cambiar termoelemento
Calentador instantáneo no se enciende cuando el termostato mezcla agua caliente con agua fría	- Filtros sucios	- Limpiar/cambiar filtros
	- Válvula anti-retorno cerrada	- Cambiar válvula anti-retorno

CLEANING RECOMMENDATION FOR AXOR PRODUCTS

Modern bathroom faucets, kitchen faucets and shower products are made from different materials to comply with the needs of the market with regard to design and functionality. To avoid damage to the product, it is necessary to take proper care of it.

FOR BEST RESULTS:

- / Prevent the buildup of mineral scale and /or soap residue by cleaning your Hansgrohe product(s) when needed.
- / Select a cleaning agent specifically intended for the type of product.
- / DO NOT use these types of cleaners as they will cause damage to your Hansgrohe product:
 - Any cleaning agent containing hydrochloric acid, formic acid, lye, or acetic acid.
 - Abrasive cleaning powders, pads, or brushes.
 - Steam cleaners.
 - “No rinse” cleaning agents.
- / ALWAYS follow the instructions provided by the manufacturer of the cleaning agent.
- / DO NOT mix cleaning agents, unless directed by the manufacturer.
- / DO NOT spray cleaners directly onto the product as drops could enter openings and gaps and cause damage. When using spray cleaners, spray the cleaner onto a soft cloth or sponge.
- / ALWAYS rinse your Hansgrohe product thoroughly with clear water and polish dry with a soft cloth after cleaning.

IMPORTANT

- / Residue from soaps and shampoos can cause damage. Rinse the product with clean water after each use.
- / Residue from basin/tub/tile cleaner can cause damage to faucets and fittings. Immediately rinse any overspray from the Hansgrohe product.
- / DO NOT store any cleaning agents under your Hansgrohe product, such as in a vanity unit, as the fumes may damage the product.
- / DAMAGE TO THE PRODUCT CAUSED BY IMPROPER CARE OR THE USE OF IMPROPER CLEANING AGENTS IS NOT COVERED BY THE WARRANTY.
- / IF A COMPONENT OF THE PRODUCT IS DAMAGED, REPLACE IT, AS THERE IS RISK OF INJURY.

CONSEIL DE NETTOYAGE POUR LES PRODUITS AXOR

Les robinets pour les salles de bains et les cuisines modernes ainsi que les produits récents pour les douches se composent de matériaux différents afin de satisfaire aux besoins du marché en termes de conception et de fonctionnalité. Afin d'éviter d'endommager le produit, il est nécessaire d'en prendre soin.

POUR DE MEILLEURS RÉSULTATS :

- / Empêchez l'accumulation de tarte et/ou de résidu de savon en nettoyant votre produit Hansgrohe lorsque c'est nécessaire.
- / Sélectionnez un produit de nettoyage spécifiquement prévu pour ce type de produit.
- / N'UTILISEZ PAS ces types de nettoyeurs car ils peuvent endommager votre produit Hansgrohe :
 - Tout produit de nettoyage contenant de l'acide chlorhydrique, de l'acide formique, de la potasse ou de l'acide acétique.
 - Les poudres de nettoyage, les tampons ou les brosses abrasives.
 - Les nettoyeurs à vapeur.
 - Les produits de nettoyage « sans rinçage ».
- / NE MÉLANGEZ PAS les produits de nettoyage, à moins que cela soit indiqué par le fabricant.
- / NE PULVÉRISEZ PAS les nettoyeurs directement sur le produit car des gouttes pourraient entrer dans les ouvertures et les fentes et causer des dommages. Lorsque vous utilisez des nettoyeurs par pulvérisation, pulvérisez le nettoyeur sur un chiffon ou une éponge douce.
- / Après le nettoyage rincer abondamment à l'eau claire pour éliminer intégralement les restes de détergent.

IMPORTANT

- / Les residus de produits pour le corps comme les savons liquides, shampooings, gels de douche, teintures pour cheveux, parfums, apres-rasage et vernis a ongles peuvent causer des deteriorations. Rincez le produit avec de l'eau propre après chaque utilisation.
- / Le résidu provenant des nettoyeurs pour cuvette/baignoire/carrelage peut endommager les robinets et les raccords de tuyauterie. Rincez immédiatement toute surpulvérisation sur le produit Hansgrohe.
- / De meme, il est interdit de stocker des detergents ou des produits chimiques sous les produits, par ex. dans un meuble sous lavabo, car les vapeurs qui s'en degagent risquent d'abimer les produits.
- / LES DOMMAGES AU PRODUIT CAUSÉS PAR UN MAUVAIS ENTRETIEN OU PAR L'UTILISATION DE PRODUITS DE NETTOYAGE INADÉQUATS NE SONT PAS COUVERTS PAR LA GARANTIE.
- / SI UN COMPOSANT DU PRODUIT EST ENDOMMAGÉ, REMPLACEZ-LE, CAR IL EXISTE UN RISQUE DE BLESSURE.

RECOMENDACIÓN DE LIMPIEZA PARA LOS PRODUCTOS DE AXOR

Hoy en día, las griferías de baño y de cocina así como duchas modernas se componen de materiales muy distintos para satisfacer las exigencias del mercado respecto al diseño y la funcionalidad. Para evitar daños y reclamaciones hay que tener en cuenta ciertos aspectos tanto en el uso como en su limpieza.

PARA OBTENER MEJORES RESULTADOS:

- / Evite la acumulación de restos de jabón o sarro limpiando el producto Hansgrohe cuando sea necesario.
- / Seleccione un agente de limpieza diseñado específicamente para el tipo de producto.
- / NO use estos tipos de limpiadores, ya que causarán daño a su producto Hansgrohe:
 - Agentes limpiadores que contengan ácido clorhídrico, fórmico, acético o lejía.
 - Polvos, paños o cepillos de limpieza abrasivos.
 - Limpiadores a vapor
 - Agentes de limpieza "sin enjuague".
- / SIEMPRE siga las instrucciones provistas por el fabricante del agente de limpieza.
- / NO mezcle los agentes de limpieza, a menos que esté indicado por el fabricante.
- / NO rocíe limpiadores directamente sobre el producto, ya que podrían caer gotas sobre las aberturas y espacios y causar daños. Cuando use limpiadores en spray, rocíe el limpiador sobre un paño suave o esponja.
- / SIEMPRE enjuague su producto Hansgrohe con agua limpia y séquelo y lústrelo con un paño suave después de la limpieza.

IMPORTANTE

- / Los residuos de productos de aseo como jabon liquido, champus, gel de ducha, tintes de pelo, perfumes, lociones de afeitado y esmalte de unas pueden danar tambien los materiales. Enjuague el producto con agua limpia después de cada uso.
- / Los residuos de limpiadores para lavatorios, bañeras o azulejos pueden causar daño a los grifos y accesorios. Enjuague inmediatamente cualquier derrame que haya sobre el producto de Hansgrohe.
- / Tampoco pueden generarse depositos de productos de limpieza o quimicos debajo de los productos, p. ej. En un armario de lavabo. De lo contrario, los vapores generados pueden danar los productos.
- / LOS DAÑOS QUE RESULTEN DE UN CUIDADO INADECUADO O USO DE AGENTES DE LIMPIEZA INADECUADOS NO ESTÁN CUBIERTOS POR LA GARANTÍA.
- / SI SE DAÑA UN COMPONENTE DEL PRODUCTO, REEMPLÁCELO, YA QUE EXISTE RIESGO DE LESIÓN.

LIMITED CONSUMER WARRANTY

Offering our customers the highest quality at all times is a fundamental part of the Hansgrohe, Inc. company philosophy. We offer consumers a limited warranty on our hansgrohe® and AXOR® branded products.

This warranty is limited to products manufactured by Hansgrohe, Inc. that are purchased from a Hansgrohe, Inc. authorized seller by a consumer in the United States or Canada after September 1, 2019, and installed in either the United States or in Canada.

WARRANTY

Hansgrohe, Inc. warrants to the original consumer purchaser that hansgrohe and AXOR products will be free from defects in material and workmanship for as long as the original consumer purchaser owns both the product and the home in which the product was originally installed. For commercial purchasers, the warranty period is (a) one (1) year for hansgrohe products and (b) five (5) years for AXOR products, in each case from the date of purchase. The warranty period for products in the Rubbed Bronze, Matte Black and Matte White finishes are three (3) years from the date of purchase. This warranty is non-transferable.

WHAT WE WILL DO

Hansgrohe, Inc., at its option, will replace any product or part of the product that proves defective in workmanship and/ or material, under normal installation, use, service and maintenance. If Hansgrohe, Inc. is unable to provide a replacement part or product and repair is not practical or cannot be made in timely fashion, Hansgrohe, Inc. may elect to refund the purchase price in exchange for the return of the defective product. REPAIR OR REPLACEMENT (OR, IN LIMITED CIRCUMSTANCES, REFUND OF THE PURCHASE PRICE) AS PROVIDED UNDER THIS LIMITED WARRANTY IS THE EXCLUSIVE REMEDY OF THE PURCHASER.

WHAT IS NOT COVERED BY THE WARRANTY

Because Hansgrohe, Inc. is unable to control the quality of hansgrohe or AXOR products sold by unauthorized sellers, unless otherwise prohibited by law, this warranty does not cover hansgrohe or AXOR products purchased from unauthorized sellers. Authorized sellers can be found on hansgrohe and AXOR branded websites.

Labor and other expenses for disconnection, deinstallation, or return of the product for warranty service (including but not limited to proper packaging and shipping costs), or for installation or reinstallation of the product are not covered by this warranty.

Hansgrohe, Inc. shall not be liable for any damage to the product resulting from:

- reasonable wear and tear
- outdoor use
- misuse (including use of the product for an unintended application)
- freezing water
- excessive water pressure

- pipe corrosion in the home in which the product is installed
- abuse, neglect or improper or incorrectly performed installation, maintenance or repair, including the use of abrasive or caustic cleaning agents or "no-rinse" cleaning products.

This warranty does not cover: (i) accessories, connected materials and products, or related products not manufactured by Hansgrohe, Inc. (ii) any hansgrohe or AXOR product sold for display purposes or (iii) hansgrohe or AXOR products purchased from unauthorized sellers.

WHAT YOU MUST DO TO OBTAIN WARRANTY SERVICE OR INFORMATION

Contact your retailer, or contact Technical Service at:

Hansgrohe, Inc.
1492 Bluegrass Lakes Parkway
Alpharetta, GA 30004
Toll-free 800 -334- 0455

In requesting warranty service, you will need to provide:

1. The sales receipt or other evidence of the date and place of purchase.
2. A description of the problem.
3. Delivery of the product or the defective part, postage prepaid and carefully packed and insured, to:

Hansgrohe, Inc.
1492 Bluegrass Lakes Parkway
Alpharetta, GA 30004
Toll-free 800 -334- 0455

When warranty service is completed, any repaired or replacement product or part will be returned to you postage prepaid.

REVISED SEPTEMBER 1, 2019.

Limitation on Duration of Implied Warranties: Some States do not allow limitations on how long an implied warranty lasts, so the below limitations may not apply to you. TO THE MAXIMUM EXTENT PERMITTED BY APPLICABLE LAW, ANY IMPLIED WARRANTY, INCLUDING THE IMPLIED WARRANTIES OF MERCHANTABILITY AND OF FITNESS FOR A PARTICULAR PURPOSE, IS LIMITED TO THE STATUTORY PERIOD OR THE DURATION OF THIS WARRANTY, WHICHEVER IS SHORTER.

Limitation of Special, Incidental or Consequential Damages: Some States do not allow the exclusion or limitation of incidental or consequential damages, so the below limitations and exclusions may not apply to you. TO THE MAXIMUM EXTENT PERMITTED BY APPLICABLE LAW, THIS WARRANTY DOES NOT COVER, AND HANSGRÖHE, INC. SHALL NOT BE LIABLE FOR, ANY SPECIAL, INCIDENTAL OR CONSEQUENTIAL DAMAGES (INCLUDING LABOR CHARGES TO REPAIR, REPLACE, INSTALL OR REMOVE THIS PRODUCT), WHETHER ARISING OUT OF BREACH OF ANY EXPRESS OR IMPLIED WARRANTY, BREACH OF CONTRACT, TORT, OR OTHERWISE. HANSGRÖHE, INC. SHALL NOT BE LIABLE FOR ANY DAMAGE TO THE PRODUCT RESULTING FROM REASONABLE WEAR AND TEAR, OUTDOOR USE, MISUSE (INCLUDING USE OF THE PRODUCT FOR AN UNINTENDED APPLICATION), FREEZING WATER, EXCESSIVE WATER PRESSURE, PIPE CORROSION IN THE HOME IN WHICH THE PRODUCT IS INSTALLED, ABUSE, NEGLIGENCE OR IMPROPER OR INCORRECTLY PERFORMED INSTALLATION, MAINTENANCE OR REPAIR, INCLUDING THE USE OF ABRASIVE OR CAUSTIC CLEANING AGENTS OR "NO-RINSE" CLEANING PRODUCTS.

Notice to residents of the State of New Jersey: The provisions of this warranty, including its limitations, are intended to apply to the fullest extent permitted by the laws of the State of New Jersey.

This warranty gives you specific legal rights, and you may also have other rights which vary from state to state.

PRODUCT INSTRUCTIONS AND QUESTIONS

Upon purchase or prior to installation, please carefully inspect your product for any damage or visible defect. Prior to installing, always carefully study the enclosed instructions on the proper installation and the care and maintenance of this product.

If you have questions at any time about the use, installation or performance of your product, or the Limited Warranty, please write us or call us toll-free at 800-334-0455.

AXOR

AXOR / Hansgrohe, Inc.
1490 Bluegrass Lakes Parkway
Alpharetta, GA 30004
Tel. 800-334-0455
Fax 770-889-1783

axor-design.com