

Directions For Application, Use and Care

Application

The Drive Sensor Basic Alarm is used with a sensor pad to alert staff that a patient is about to wander. When sensor is activated an 85dB or 100dB alarm tone sounds notifying caregiver. LED indicates low battery. Alarm features convenient ON/OFF switch. 9V battery included or AC adaptable (adapter sold separately).

Installation

1. Insert one 9V battery into battery compartment of the alarm. Slide compartment door open.
2. Secure to chair or bed using hook and loop straps. If using mounting bracket to attach alarm box to chair or bed, remove belt clip from back of alarm unit. Peel backing from pressure sensitive hook (included), and attach to back of alarm box. Press firmly to attach alarm to mounting bracket.
3. BED: Mount alarm box toward foot of bed. Route cord toward footboard of bed. Keep cord clear of siderails and all other moving parts. Secure excess cord for patient/staff safety.
4. CHAIR: Mount alarm box out of patient's reach. Route cord toward back of chair. Keep cord clear of wheels and all other moving parts. Secure excess cord for patient/staff safety (Figure 2).

figure 1

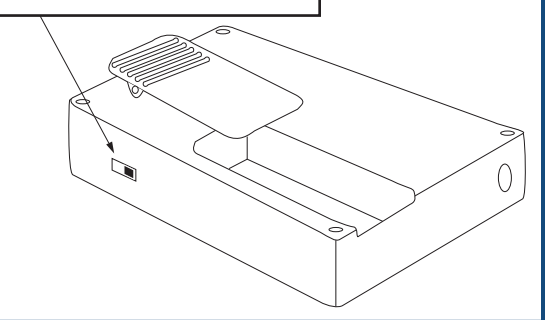
Power Switch
Off, Low 85dB or Hi 100dB

Use

1. Move volume switch to Low or Hi, depending on required alarm volume for environment (Figure 1).
2. Plug sensor pad into telephone-type jack on side of alarm box. Inspect wires for damage before connecting. Replace if damage to wiring or device is present. Once initial pressure or contact is detected by alarm unit, unit will beep once to alert caregiver that unit is active.
3. If resident leaves the chair or bed or unbuckles the seat belt, alarm will sound and LED will flash. Unit will sound continuously until patient returns to bed or chair, or power switch is moved to the OFF position.

Note: Battery power is low if LED flashes continuously and sounds a single beep every 30 seconds. Replace battery immediately. If alarm tone decreases in volume, replace battery immediately.

locate mounting bracket
out of patient's reach, low
on back of wheelchair

figure 2

Testing the System

1. Test pad by applying pressure to pad for 3 seconds and releasing. Alarm will sound when pressure is released. Test lap cushion by connecting activation strap and releasing. Alarm will sound when strap is released. Note: If using alarm unit with optional delay settings, pressure must be removed from pad for entire delay cycle before alarm will sound.
2. Always test alarm unit and pad together before each use. Never use if alarm fails to sound when tested. Always retest if alarm unit is dropped.
3. Inspect pad and all connections for damage. Do not use if damaged. Replace immediately.

Caution

- This device is not a substitute for routine visual monitoring of patients. It will not prevent falls. Staff must make frequent routine visual inspections to ensure sensor pad is properly placed and alarm unit is powered on.
- Use of alarm unit may not be suitable for all “High Risk” patients. Other safety measures may still be necessary to ensure patient safety.

Optional Nurse Call Feature for Bedside Use

Plug one end of Nurse Call Cable (sold separately) into top of alarm unit and opposite end of cable into a compatible nurse call plug located at patient’s bedside. When alarm sounds, a signal will activate nurse call station just as it would if emergency button were pressed.

Care

- Wipe clean using standard cleaning disinfectants.
- Do not immerse in fluids.
- Check function before each use and if alarm unit is dropped. Do not use equipment that has been damaged.

Precautions

- Avoid contact with water: remove alarm unit from wheelchair before washing.
- Alarm emits extremely loud signal. Do not point unit directly at yourself or anyone else unless you need immediate assistance. Do not place unit near patient’s ear as possible hearing loss can occur.

Maintenance

Check alarm before each use to ensure proper alarm function. If alarm fails to sound, replace battery. If alarm fails to work with a new battery, then inspect and clean battery terminals.

1 Year Limited Warranty

Your Drive brand product is warranted to be free of defects in materials and workmanship for one year of the original consumer purchaser.

This device was built to exacting standards and carefully inspected prior to shipment. This 1 year Limited Warranty is an expression of our confidence in the materials and workmanship of our products and our assurance to the consumer of years of dependable service.

This warranty does not cover device failure due to owner misuse or negligence, or normal wear and tear. The warranty does not extend to non-durable components, such as rubber accessories, casters, and grips, which are subject to normal wear and need periodic replacement.

If you have a question about your Drive device or this warranty, please contact an authorized Drive dealer.

tamper-proof chair and bed patient alarm with reset button

item # 13608
item # 13609

Directions For Application, Use and Care

Application

The Drive Sensor Basic Alarm is used with a sensor pad to alert staff that a patient is about to wander. When sensor is activated an 85dB or 100dB alarm tone sounds notifying caregiver. LED indicates low battery. Alarm features convenient ON/OFF switch. 9V battery included or AC adatable (adapter sold separately).

Installation

1. Insert one 9V battery into battery compartment of the alarm. To open compartment, slide compartment door open.
2. If using mounting bracket to attach alarm box to chair or bed, remove belt clip from back of alarm unit. Peel backing from pressure sensitive hook (included), and attach to back of alarm box. Press firmly to attach alarm to mounting bracket.
3. BED: Mount alarm box toward foot of bed. Route cord toward footboard of bed. Keep cord clear of siderails and all other moving parts. Secure excess cord for patient/staff safety.
4. CHAIR: Mount alarm box out of patient's reach. Route cord toward back of chair. Keep cord clear of wheels and all other moving parts. Secure excess cord for patient/staff safety (Figure 2).

Use

1. Move volume switch to Low or Hi, depending on required alarm volume for environment (Figure 1).
2. Plug sensor pad into telephone-type jack on side of alarm box. Inspect wires for damage before connecting. Replace if damage to wiring or device is present. Once initial pressure or contact is detected by alarm unit, unit will beep once to alert caregiver that unit is active.
3. If resident leaves the chair or bed or unbuckles the seat belt, alarm will sound and LED will flash. Unit will sound continuously until patient returns to bed or chair, or power switch is moved to the OFF position.

Note: Battery power is low if LED flashes continuously and sounds a single beep every 30 seconds. Replace battery immediately. If alarm tone decreases in volume, replace battery immediately.

Testing the System

1. Test pad by applying pressure to pad for 3 seconds and releasing. Alarm will sound when pressure is released. Test lap cushion by connecting activation strap and releasing. Alarm will sound when strap is released. Note: If using alarm unit with optional delay settings, pressure must be removed from pad for entire delay cycle before alarm will sound.
2. Always test alarm unit and pad together before each use. Never use if alarm fails to sound when tested. Always retest if alarm unit is dropped.
3. Inspect pad and all connections for damage. Do not use if damaged. Replace immediately.

figure 1

Power Switch
Off, Low 85dB or Hi 100dB

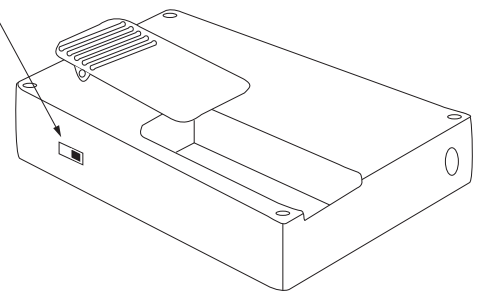

locate mounting bracket
out of patient's reach, low
on back of wheelchair



figure 2

Caution

- This device is not a substitute for routine visual monitoring of patients. It will not prevent falls. Staff must make frequent routine visual inspections to ensure sensor pad is properly placed and alarm unit is powered on.
- Use of alarm unit may not be suitable for all “High Risk” patients. Other safety measures may still be necessary to ensure patient safety.

Optional Nurse Call Feature for Bedside Use

Plug one end of Nurse Call Cable (sold separately) into top of alarm unit and opposite end of cable into a compatible nurse call plug located at patient’s bedside. When alarm sounds, a signal will activate nurse call station just as it would if emergency button were pressed.

Care

- Wipe clean using standard cleaning disinfectants.
- Do not immerse in fluids.
- Check function before each use and if alarm unit is dropped. Do not use equipment that has been damaged.

Precautions

- Avoid contact with water: remove alarm unit from wheelchair before washing.
- Alarm emits extremely loud signal. Do not point unit directly at yourself or anyone else unless you need immediate assistance. Do not place unit near patient’s ear as possible hearing loss can occur.

Maintenance

Check alarm before each use to ensure proper alarm function. If alarm fails to sound, replace battery. If alarm fails to work with a new battery, then inspect and clean battery terminals.

1 Year Limited Warranty

Your Drive branded product is warrantied to be free of defects in materials and workmanship for 1 year from the date of purchase for the original consumer purchaser.

This device was built to exacting standards and carefully inspected prior to shipment. This Limited 1 Year Warranty is an expression of our confidence in the materials and workmanship of our products and our assurance to the consumer of years of dependable service.

This warranty does not cover device failure due to owner misuse or negligence, or normal wear and tear. The warranty does not extend to non-durable components, such as rubber accessories, casters, and grips, which are subject to normal wear and need periodic replacement.

If you have a question about your Drive device or this warranty, please contact an authorized Drive dealer.