

INSTRUCTION MANUAL

Fairmont[®]

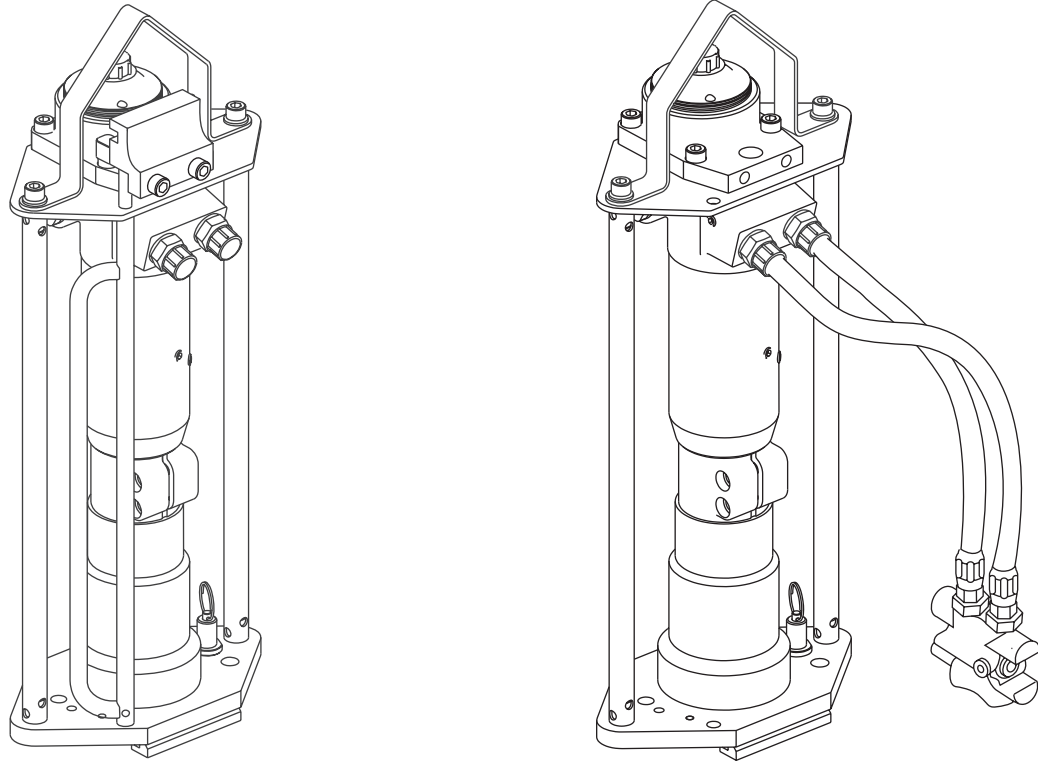

HPD-T and HPD-HV Hydraulic Sign Post Drivers



Read and understand all of the instructions and safety information in this manual before operating or servicing this tool.

Table of Contents

Description 2
 Safety 2
 Purpose of this Manual 2
 Other Publications 2
 Important Safety Information 3–5
 Identification 6
 Specifications 7–8
 Hoses and Fittings 9
 Typical Setup 9
 Hose Connections—HPD-T 9
 Hose Connections—HPD-HV 10
 Adapters 11
 Operation 12–13
 Maintenance 14–15
 Troubleshooting 16
 Illustrations and Parts Lists 17–20
 Accessories 20

Description

The HPD-T and HPD-HV Fairmont Sign Post Drivers are heavy-duty, hydraulically powered reciprocating tools designed for driving various types of sign posts into the ground. The high power-to-weight ratio and low vibration reduce operator fatigue and increase productivity.

These drivers have a lifting bracket and two side handles for easy positioning.

The HPD-HV has a remote double-acting operating valve that allows operation on either open-center or closed-center hydraulic systems.

Safety

Safety is essential in the use and maintenance of Fairmont tools and equipment. This manual and any markings on the tool provide information for avoiding hazards and unsafe practices related to the use of this tool. Observe all of the safety information provided.

Purpose of this Manual

This manual is intended to familiarize personnel with the safe operation and maintenance procedures for the following Fairmont tools:

- HPD-T Sign Post Driver with Trigger
- HPD-HV Sign Post Driver with Remote Control Valve

Keep this manual available to all personnel.

Replacement manuals are available upon request at no charge.

Other Publications

Tool Owners/Users

SAE Standard J1273 (Hose and Hose Assemblies):
 Publication 999 3032.3

All specifications are nominal and may change as design improvements occur. Greenlee Textron Inc. shall not be liable for damages resulting from misapplication or misuse of its products.

Loctite and 242 are registered trademarks of Loctite Corporation.

KEEP THIS MANUAL

IMPORTANT SAFETY INFORMATION

	<p>SAFETY ALERT SYMBOL</p>
<p>This symbol is used to call your attention to hazards or unsafe practices which could result in an injury or property damage. The signal word, defined below, indicates the severity of the hazard. The message after the signal word provides information for preventing or avoiding the hazard.</p>	
<p>⚠ DANGER</p>	
<p>Immediate hazards which, if not avoided, WILL result in severe injury or death.</p>	
<p>⚠ WARNING</p>	
<p>Hazards which, if not avoided, COULD result in severe injury or death.</p>	
<p>⚠ CAUTION</p>	
<p>Hazards or unsafe practices which, if not avoided, MAY result in injury or property damage.</p>	

	<p>⚠ WARNING</p>
	<p>Skin injection hazard: Oil under pressure easily punctures skin causing serious injury, gangrene or death. If you are injured by escaping oil, seek medical attention immediately.</p> <ul style="list-style-type: none"> • Do not use hands to check for leaks. • Do not hold hose or couplers while the hydraulic system is pressurized. • Depressurize the hydraulic system before servicing.

<p>⚠ WARNING</p>
<p>Do not exceed the following hydraulic power source maximums:</p> <ul style="list-style-type: none"> • Hydraulic flow: 30 l/min (8 gpm) • Pressure relief: 160 bar (2300 psi) • Back pressure: 15 bar (200 psi) <p>Failure to observe this warning could result in severe injury or death.</p>

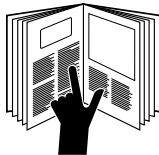
	<p>⚠ WARNING</p>
	<p>Read and understand all of the instructions and safety information in this manual before operating or servicing this tool.</p> <p>Failure to observe this warning could result in severe injury or death.</p>

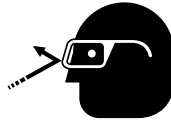
	<p>⚠ WARNING</p>
	<p>Wear eye protection when operating or servicing this tool.</p> <p>Failure to wear eye protection could result in serious eye injury from flying debris or hydraulic oil.</p>

	<p>⚠ WARNING</p>
	<p>Wear hearing protection when using this tool.</p> <p>Long-term exposure to high noise levels could result in hearing loss.</p>

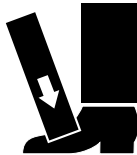
	<p>⚠ WARNING</p>
	<p>Wear foot protection when using this tool.</p> <p>Failure to observe this warning could result in serious injury.</p>

IMPORTANT SAFETY INFORMATION

	⚠ WARNING
	<p>Wear a hard hat when using this tool.</p> <p>Failure to observe this warning could result in serious injury or death.</p>

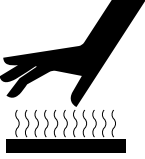
	⚠ WARNING
	<p>Tool and accessory may be hot during and after operation. Allow to cool before handling, or handle with heat-resistant gloves.</p> <p>Contact with hot surfaces could result in serious injury.</p>

	⚠ WARNING
	<p>Electric shock hazard:</p> <p>This tool is not insulated. When using this unit near energized electrical lines:</p> <ul style="list-style-type: none"> • Use only certified non-conductive hoses and proper personal protective equipment. • Select and maintain the hydraulic fluid to meet the minimum dielectric standards required by your safety department. <p>Failure to observe this warning could result in severe injury or death.</p>

⚠ WARNING
<p>Do not disconnect tool, hoses, or fittings while the power source is running or if the hydraulic fluid is hot. Hot hydraulic fluid could cause serious burns.</p>

⚠ WARNING
<p>Do not reverse hydraulic flow. Operation with hydraulic flow reversed can cause tool malfunction. Connect the supply (pressure) hose and return (tank) hose to the proper ports.</p> <p>Failure to observe this warning could result in severe injury or death.</p>

⚠ WARNING
<p>Do not change accessories, inspect, adjust or clean tool when it is connected to a power source.</p> <p>Accidental startup could result in serious injury or death.</p>

⚠ WARNING
<p>Serious injury could result if the operator does not maintain control of the tool.</p> <ul style="list-style-type: none"> • Wear slip-proof gloves when operating this tool. • Maintain a firm grip on the tool, using both hands at all times. • Do not lock the trigger in the power-ON position. Operator cannot stop tool when the trigger is locked. <p>Failure to observe these warnings could result in severe injury or death.</p>

⚠ WARNING
<p>Accumulator is charged with nitrogen under high pressure. This pressure must be unloaded before dismounting.</p> <p>Failure to observe this warning could result in severe injury or death.</p>

IMPORTANT SAFETY INFORMATION**⚠ CAUTION**

Vibration hazard:

Apply just enough pressure to do the work. Applying excess pressure to the tool can cause operator discomfort or temporary numbness.

Failure to observe this precaution may result in injury.

⚠ CAUTION

These tools can weigh more than 25 kg (55 lb) and require two persons to lift and transport.

Failure to observe this precaution may result in injury.

⚠ CAUTION

Hydraulic oil can cause skin irritation.

- Handle the tool and hoses with care to prevent skin contact with hydraulic oil.
- In case of accidental skin contact with hydraulic oil, wash the affected area immediately to remove the oil.

Failure to observe these precautions may result in injury.

⚠ CAUTION

- Inspect the hydraulic hoses and couplings every operating day. Repair or replace if leakage, cracking, wear, or damage is evident. Damaged hoses or couplings may fail, resulting in injury or property damage.
- Use this tool for manufacturer's intended purpose only. Use other than that which is described in this manual may result in injury or property damage.
- Make sure all bystanders are clear of the work area when handling, starting, and operating the tool. Nearby personnel may be injured by flying or falling debris or by flying parts in the event of a tool malfunction.

IMPORTANT

Procedure for connecting or disconnecting hydraulic hoses, fittings or components:

1. Move the flow lever on the power source to the OFF position.
2. Stop the hydraulic power source.
3. Follow the sequence under "Hose Connections" to prevent pressure buildup. In case some pressure has built up, loosen hoses, fittings or components slowly.

IMPORTANT

Emergency stop procedure:

1. Release the trigger or move the control spool to the OFF position.
2. Shut off the hydraulic power source.

Note: Keep decals clean and legible. Replace decals when necessary.

When disposing of any components (hydraulic hoses, hydraulic fluid, worn parts, etc.), do so in accordance with federal, state, and local laws or ordinances.

Identification

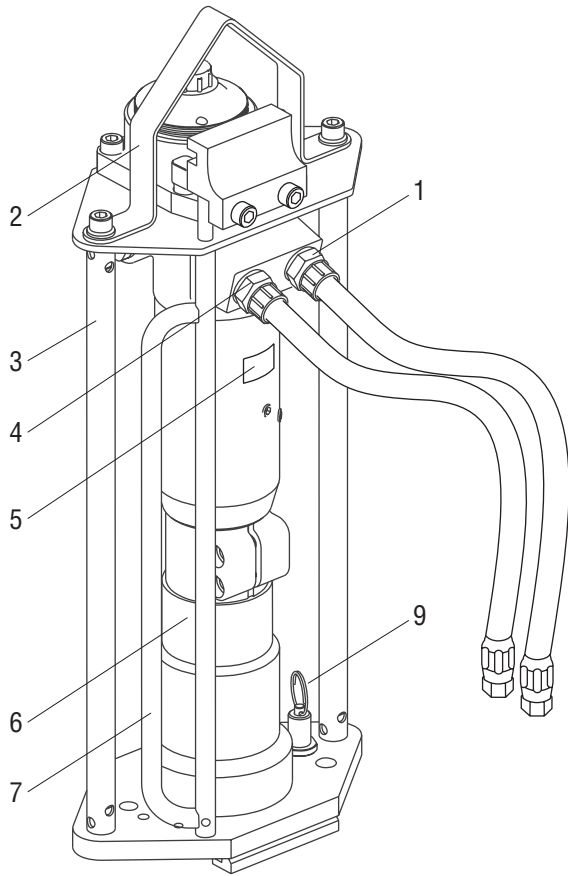

HPD-T

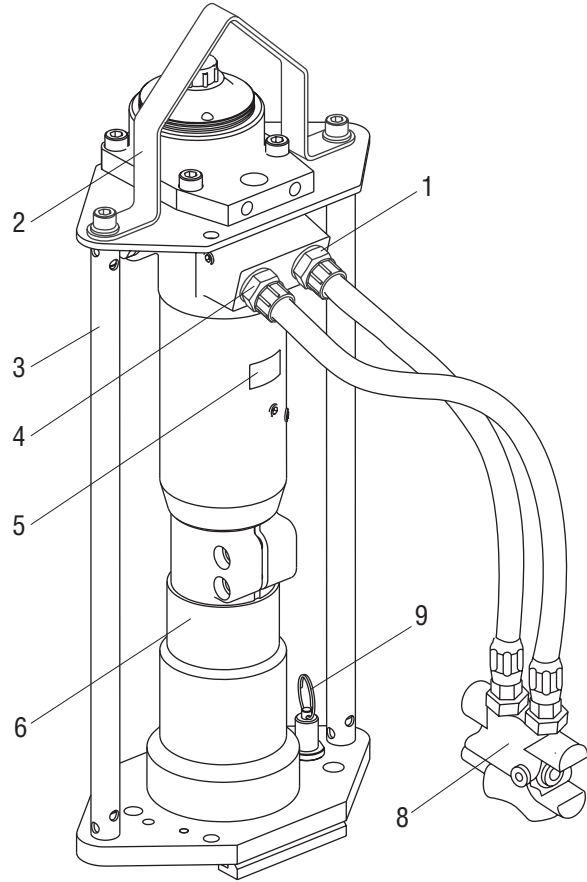

HPD-HV

Sign Post Drivers

- | | |
|---------------------------|----------------------------------|
| 1. Return (tank) Port | 6. Front Head |
| 2. Lifting Bracket | 7. Trigger Bar (HPD-T) |
| 3. Side Handles | 8. Remote Control Valve (HPD-HV) |
| 4. Supply (pressure) Port | 9. Adapter Release Ring |
| 5. Serial Number | |

Specifications

HPD-T and HPD-HV

Type of Hydraulic System

- HPD-T Open-center
- HPD-HV Open-center or closed-center

Weight

- HPD-T
 - Without Hoses and Adapter 30.6 kg (67.5 lb)
 - With Hoses and Adapter 34 kg (75 lb)

HPD-HV

- Without Hoses, Remote Control Valve, and Adapter 28.8 kg (63.5 lb)
- With Hoses, Remote Control Valve, and Adapter 32 kg (70.5 lb)

Length x Width x Height

- without Adapter 655 mm x 254 mm x 177 mm (25.8" x 10.0" x 6.7")

Working Pressure 105 to 125 bar (1500 to 1800 psi)

Hydraulic Oil

Working Temperature 30 to 70 °C (86 to 158 °F)

Accumulator Charging

Pressure (nitrogen) 50 bar (723 psi)

Blow Frequency

- @ 30 l/min (8 gpm) 25 Hz (1500/min)

Hydraulic Ports at Tool 1/2" BSP

Hydraulic Ports at Remote Control Valve (HPD-HV)

- Pressure 9/16–18 SAE O-ring boss
- Return 3/4–16 SAE O-ring boss

Hydraulic Power Source

⚠ WARNING

Do not exceed the following hydraulic power source maximums:

- Hydraulic flow: 30 l/min (8 gpm)
- Pressure relief: 160 bar (2300 psi)
- Back pressure: 15 bar (200 psi)

Failure to observe this warning could result in severe injury or death.

- Optimal performance occurs at maximum flow.
- Maximum hydraulic fluid temperature must not exceed 70 °C (158 °F). A sufficient oil cooling capacity is needed to limit the hydraulic fluid temperature.
- Hydraulic flow must not exceed 30 l/min (8 gpm). Install a flow meter in the return line to measure the rate of hydraulic flow before using the tool.
- Pressure relief valve setting must not exceed 160 bar (2300 psi) at your tool's maximum flow. Locate the pressure relief valve in the supply circuit to limit excessive hydraulic pressure to the tool.

Hydraulic Schematic

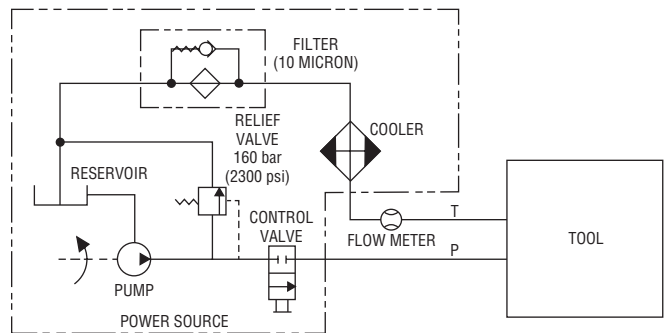

Specifications (cont'd)

Recommended Hydraulic Fluid

Viscosity

Ideal 20 to 40 cSt

Allowable 15 to 1000 cSt

Viscosity Index Min. 100

Standard mineral or synthetic oil can be used.

When the tool works continuously, the oil temperature will steady at a certain level called the oil working temperature. Depending on the nature of the job and the cooling capacity of the system, the oil working temperature will be 20 °C to 40 °C (68 °F to 104 °F) above the air temperature. At working temperature, the oil viscosity must be within the ideal area. The tool may not be operated if the oil viscosity is not within the allowable area or if the temperature is not within -20 °C to 70 °C (-4 °F to 158 °F).

The viscosity index expresses the dependence of the viscosity on the temperature. Thus, a high viscosity index is preferable so that the oil can be used within a wide temperature interval.

Applicable Oil Types

TYPE OF OIL	(-4 °F)	(14 °F)	(32 °F)	(50 °F)	(68 °F)	(86 °F)	(104 °F)	(122 °F)	(140 °F)	(158 °F)	Viscosity at 40 °C (104 °F)
	-20 °C	-10 °C	0 °C	10 °C	20 °C	30 °C	40 °C	50 °C	60 °C	70 °C	
BP Biohyd 32											36.0 cSt
BP Biohyd 46											44.0 cSt
BP Biohyd SE 46											46.0 cSt
BP Biohyd SE 68											72.2 cSt
CASTROL Biotech HTG 32											36.8 cSt
MOBIL EAL 224 H											36.0 cSt
Q8 Holbein 46											48.4 cSt
SHELL Naturelle HF											35.0 cSt
STATOIL M 32-68											47.4 cSt
SHELL Tellus oil T46											46.0 cSt
ESSO Univis N46											45.7 cSt
TEXACO Rando oil HDZ46											51.0 cSt
MOBIL DTE 15											44.9 cSt

 Permitted oil temperature

 Recommended oil temperature

Hoses and Fittings

Installation and Maintenance

Refer to publication 999 3032.3, SAE J1273 (Hose and Hose Assemblies).

Replacement

Refer to a Fairmont catalog or bulletin 999 1032.2 for a complete selection of hoses and fittings.

Hose Connections—HPD-T

⚠ WARNING

Do not disconnect tool, hoses, or fittings while the power source is running or if the hydraulic fluid is hot. Hot hydraulic fluid could cause serious burns.

Connecting Hoses

1. Move the flow lever on the power source to the OFF position.
2. Stop the hydraulic power source.
3. Connect the return hose to the return port on the power source, then to the return port on the tool.
4. Connect the pressure hose to the pressure port on the tool, then to the pressure port on the power source.

Disconnecting Hoses

1. Move the flow lever on the power source to the OFF position.
2. Stop the hydraulic power source.
3. Disconnect the pressure hose from the power source, then from the tool.
4. Disconnect the return hose from the tool, then from the power source.
5. Install dust caps over the ports to prevent contamination.

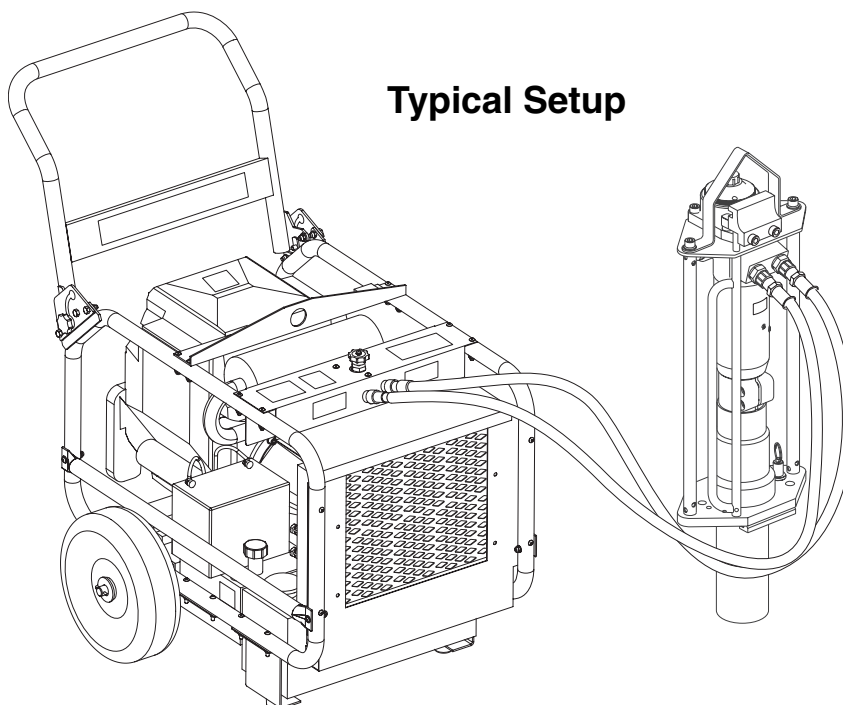

Hose Connections—HPD-HV

⚠ WARNING

Do not disconnect tool, hoses, or fittings while the power source is running or if the hydraulic fluid is hot. Hot hydraulic fluid could cause serious burns.

Connecting Hoses on a Closed-Center Hydraulic System

1. Stop the hydraulic power source. Refer to the illustration below.

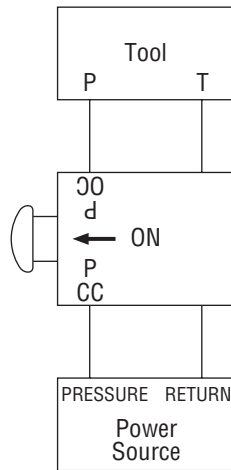

Closed-Center Hydraulic System Hose Connections

2. Connect the return (tank) hose from the tool's tank port (port T) to the control valve return port (next to the port labeled P/OC, the open-center pressure port).
3. Connect the return (tank) hose from the control valve's tank port (next to the port labeled P/CC, the closed-center pressure port) to the power source's tank port (port T).
- Note: Connect the return (tank) hoses before the supply (pressure) hoses to prevent pressure buildup inside the tool.*
4. Connect the supply (pressure) hose from the tool's pressure port (port P) to the control valve's open-center pressure port (port P/OC).
5. Connect the supply (pressure) hose from the control valve's closed-center pressure port (port P/CC) to the power source's pressure port (port P).

Connecting Hoses on an Open-Center Hydraulic System

1. Stop the hydraulic power source. Refer to the illustration below.

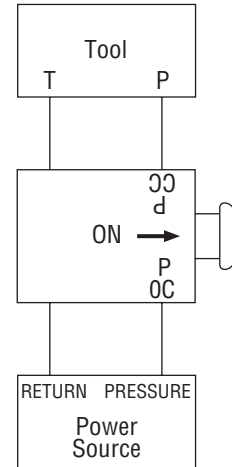

Open-Center Hydraulic System Hose Connections

2. Connect the return (tank) hose from the tool's tank port (port T) to the control valve return port (next to the port labeled P/CC, the closed-center pressure port).
3. Connect the return (tank) hose from the control valve's tank port (next to the port labeled P/OC, the open-center pressure port) to the power source's tank port (port T).
- Note: Connect the return (tank) hoses before the supply (pressure) hoses to prevent pressure buildup inside the tool.*
4. Connect the supply (pressure) hose from the tool's pressure port (port P) to the control valve's closed-center pressure port (port P/CC).
5. Connect the supply (pressure) hose from the control valve's open-center pressure port (port P/OC) to the power source's pressure port (port P).

Disconnecting Hoses

1. Move the flow lever on the power source to the OFF position.
2. Stop the hydraulic power source.
3. Disconnect hoses in the reverse order of the connection sequence.
4. Install dust caps over the ports to prevent contamination.

Adapters

Use the following Fairmont adapters on the sign post drivers to accommodate various configurations of sign posts. Refer to the figures to identify the proper adapter and orientation for different types of sign posts.

Cat. No.	UPC No.	Description
78-3310- UA	49532	Universal head adapter
RA96	49533	3.8" (96 mm) round head adapter
SA54	49534	2-1/8" (54 mm) square head adapter

Round Head Adapter

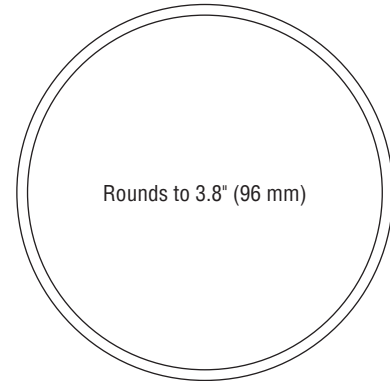

Universal Adapter

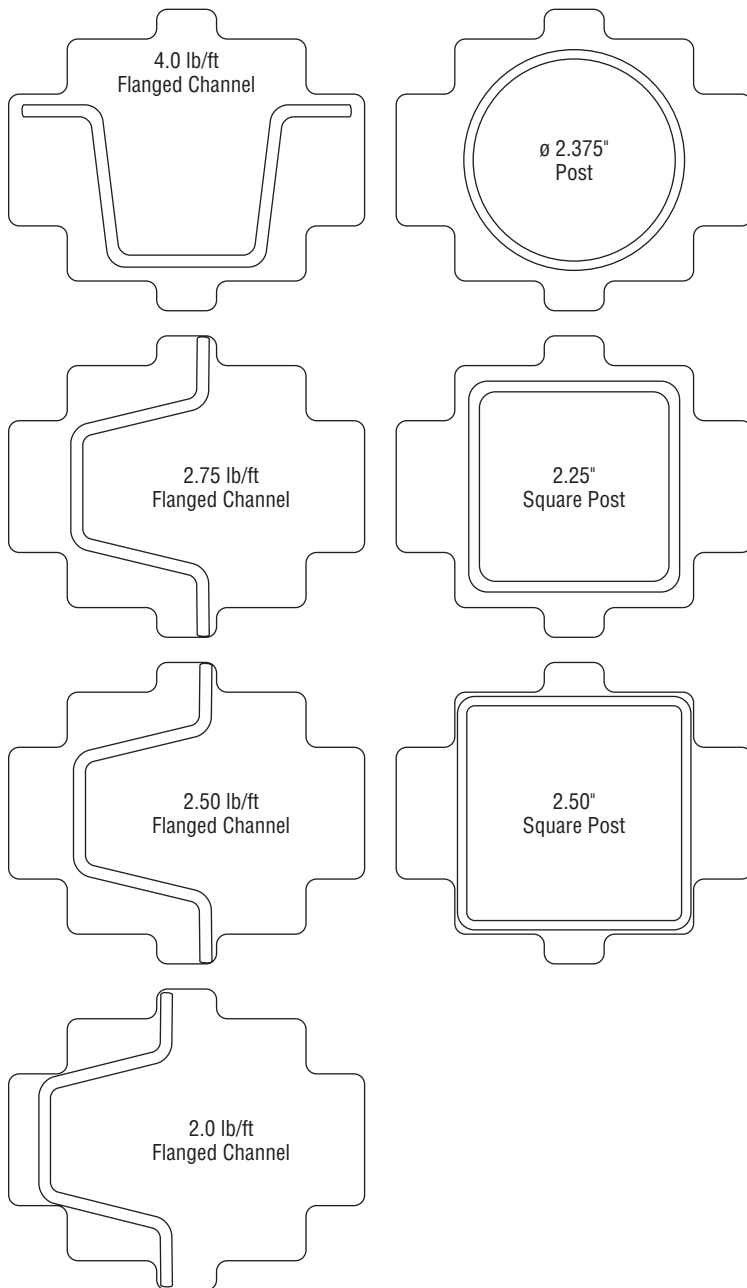

Square Head Adapter

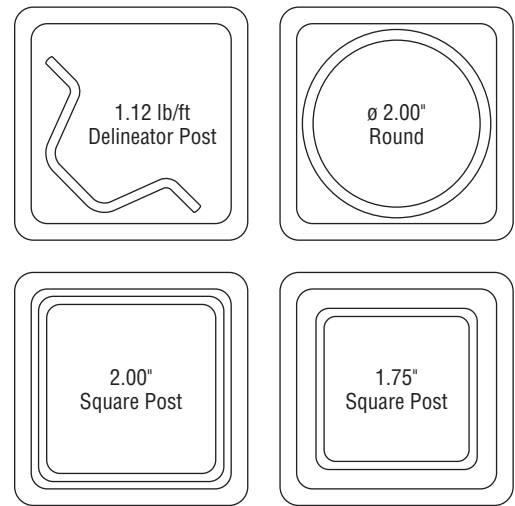



Operation

	<p>⚠ WARNING</p>
	<p>Electric shock hazard: This tool is not insulated. When using this unit near energized electrical lines:</p> <ul style="list-style-type: none"> • Use only certified non-conductive hoses and proper personal protective equipment. • Select and maintain the hydraulic fluid to meet the minimum dielectric standards required by your safety department. <p>Failure to observe this warning could result in severe injury or death.</p>

	<p>⚠ WARNING</p>
	<p>Skin injection hazard: Oil under pressure easily punctures skin causing serious injury, gangrene or death. If you are injured by escaping oil, seek medical attention immediately.</p> <ul style="list-style-type: none"> • Do not use hands to check for leaks. • Do not hold hose or couplers while the hydraulic system is pressurized. • Depressurize the hydraulic system before servicing.

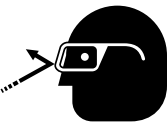
<p>⚠ WARNING</p>
<p>Do not exceed the following hydraulic power source maximums:</p> <ul style="list-style-type: none"> • Hydraulic flow: 30 l/min (8 gpm) • Pressure relief: 160 bar (2300 psi) • Back pressure: 15 bar (200 psi) <p>Failure to observe this warning could result in severe injury or death.</p>

	<p>⚠ WARNING</p>
	<p>Wear eye protection when operating or servicing this tool. Failure to wear eye protection could result in serious eye injury from flying debris or hydraulic oil.</p>

	<p>⚠ WARNING</p>
	<p>Wear hearing protection when using this tool. Long-term exposure to high noise levels could result in hearing loss.</p>

	<p>⚠ WARNING</p>
	<p>Wear foot protection when using this tool. Failure to observe this warning could result in serious injury.</p>

	<p>⚠ WARNING</p>
	<p>Wear a hard hat when using this tool. Failure to observe this warning could result in serious injury or death.</p>

<p>⚠ WARNING</p>
<p>Serious injury could result if the operator does not maintain control of the tool.</p> <ul style="list-style-type: none"> • Wear slip-proof gloves when operating this tool. • Maintain a firm grip on the tool, using both hands at all times. • Do not lock the trigger in the power-ON position. Operator cannot stop tool when the trigger is locked. <p>Failure to observe these warnings could result in severe injury or death.</p>

<p>IMPORTANT</p>
<p>Emergency stop procedure:</p> <ol style="list-style-type: none"> 1. Release the trigger or move the control spool to the OFF position. 2. Shut off the hydraulic power source.

Operation (cont'd)

1. Pull up on the adapter release ring. Slide the appropriate adapter into the front head. Release the adapter release ring so that the adapter is secured to the front head.

Note: The constant vibration of this tool will accelerate wear of the adapter release mechanism. To extend the service life, use a 1/2" cap screw and nut to secure the adapter to the tool.

2. Start the power source.

Note: Allow the power source to run for a few minutes to warm the hydraulic fluid.

Option: Install a drive cap, as shown, to protect the end of the sign post.

3. Slide the sign post into the driver, as shown.

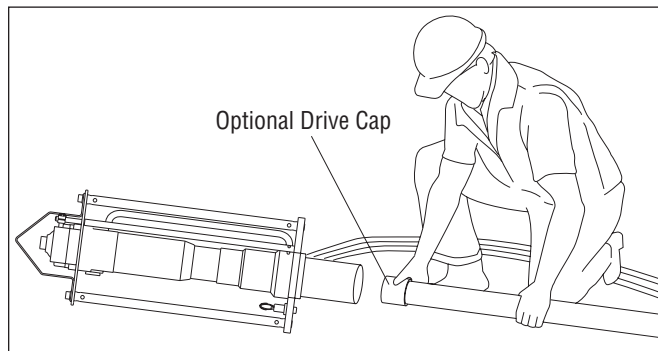
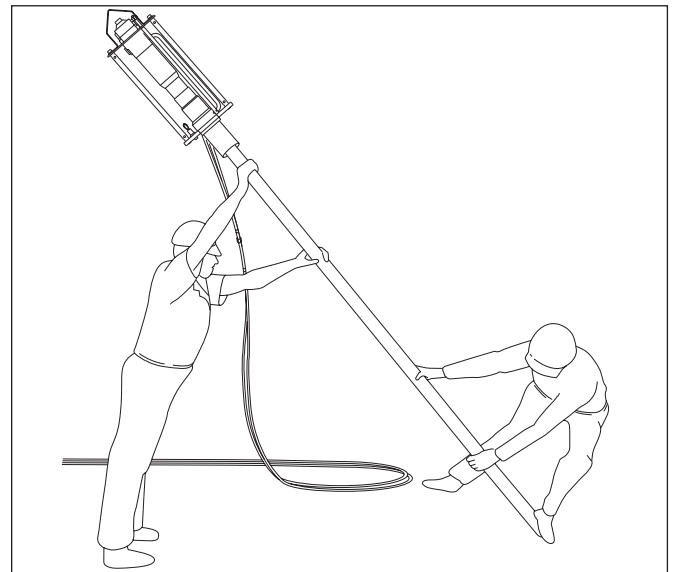

4. Lift the post and driver to a vertical position, as shown.

Notes: Posts longer than 2 m (6') may require a second person to lift the driver and steady the post.

When the sign post driver is within reach, grasp both handles firmly.

5. To start the tool:

HPD-T: Squeeze the trigger bar toward the handle. Use a partial squeeze for slow driving, or a full squeeze for fast driving.

HPD-HV: Move the control spool on the remote valve to the ON position.

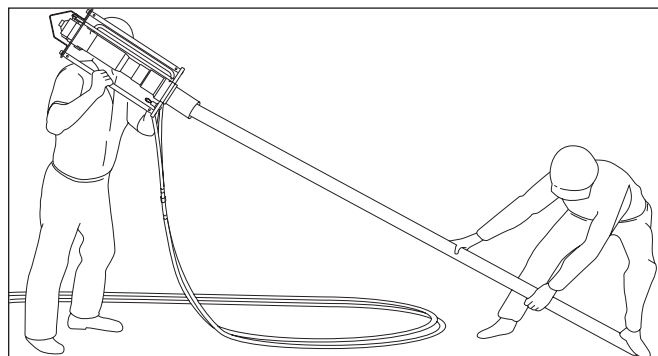
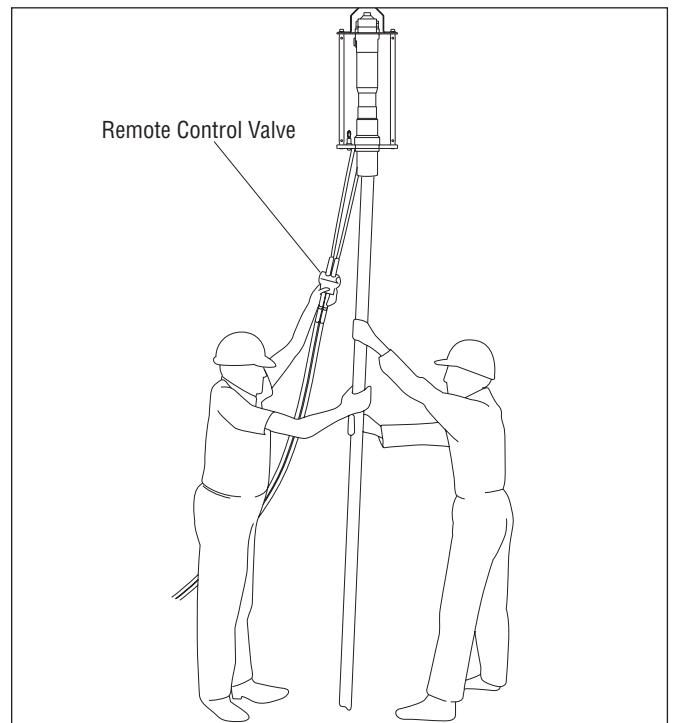

6. To stop the tool:

HPD-T: Release the trigger bar.

HPD-HV: Move the control spool on the remote valve to the OFF position.

7. After the post is driven, remove the driver and the spacer (if used).

Note: If you need to drive the post further into the ground, shut off the power source, depressurize the hydraulic system, and remove the adapter. Start the power source. Place the sign post driver directly onto the sign post and drive the post to the required height.

8. When the tool is not in use, stop the power source to reduce heat and wear on tool components.

Maintenance

⚠ WARNING

Do not change accessories, inspect, adjust or clean tool when it is connected to a power source. Accidental startup could result in serious injury or death.

⚠ WARNING

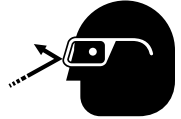

Wear eye protection when operating or servicing this tool. Failure to wear eye protection could result in serious eye injury from flying debris or hydraulic oil.

Use this maintenance schedule to maximize the tool's service life.

Note: Keep decals clean and legible. Replace decals when necessary.

When disposing of any components (hydraulic hoses, hydraulic fluid, worn parts, etc.), do so in accordance with federal, state, and local laws or ordinances.

Daily

1. Wipe all tool surfaces clean.
2. Inspect the hydraulic hoses and fittings for signs of leaks, cracks, wear, or damage. Replace if necessary.
3. Install dust caps over the hydraulic ports when the tool is disconnected.
4. Apply a light oil to all moving parts.

Monthly

Perform a thorough inspection of the hydraulic hoses and fittings as described in publication 999 3032.3, SAE J1273 (Hose and Hose Assemblies).

Annually

If required by your organization, have the tool inspected by an authorized Fairmont service center.

Storage

If the tool requires long-term storage, protect the striking piston against corrosion. Press the striking piston to its upper position (through the chisel bushing) by means of a tool placed upside down. As the quick-release couplings are blocked when disassembled, the striking piston must be pressed upward with the hoses mounted but the power source turned off.

Maintenance (cont'd)

Accumulator Recharging Procedure

⚠ WARNING

Accumulator is charged with nitrogen under high pressure. This pressure must be unloaded before dismounting.

Failure to observe this warning could result in severe injury or death.

1. Check that the oil inlet of the accumulator is depressurized.
2. Remove the protective cap over the charging screw (9) of the accumulator. The socket head screw must be perfectly clean.
3. Loosen the charging screw on top of the accumulator (maximum of two turns). Totally neutralize the pressure before dismounting the accumulator.
4. Unscrew the accumulator cover (10), take out the diaphragm (11), and check for leakage and damage.
5. Clean, check, and replace damaged or worn parts.
6. Grease the seal faces of the accumulator body (12) and the accumulator cover (10) with silicone.
7. Spray both sides of the diaphragm with silicone. Place the diaphragm with its bead pointing downward so that it fits in the groove of the accumulator body (12).
8. Unscrew the charging screw and replace the seal ring (13).
9. Grease the thread of the accumulator cover (10) with copper grease and tighten to approximately 200 Nm (148 ft-lb).
10. Fasten the charging screw lightly, and loosen it two turns afterward.
11. Mount the filling device on the filling socket of the accumulator cover and fasten it lightly while turning the handle (2) forward and backward, ensuring that the hexagon resiliently fits into the charging screw.
12. Close the bleeder valve (5) by turning it clockwise.
13. Connect the hose (7) to the check valve (6).
14. Connect the free end of the hose directly to the nitrogen bottle by using the reducing nipple.

Note: Use only pure nitrogen.
15. Read the pressure on the gauge (4). Carefully open the valve of the nitrogen bottle (1) and charge with nitrogen until the pressure is approximately 20% higher than required charging pressure. Close the valve of the nitrogen bottle.
16. If the gauge (4) shows too high a nitrogen pressure, loosen the bleeder valve (5) until the required pressure is achieved.

17. Close the charging screw (9) of the accumulator by turning the handle (2) clockwise.
18. Unload the nitrogen hose by opening the bleeder valve (5).
19. Dismount the filling device and check the charging screw (9) for leakage with drops of oil.
20. Fit the protective cap over the accumulator.

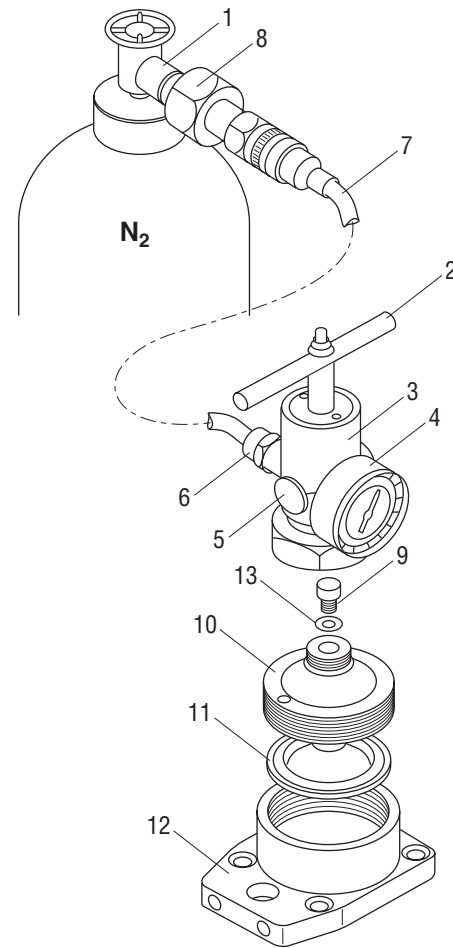

50027182 Accumulator filling device
(includes items 2–8)

50027174 Accumulator kit (fully charged)
(includes items 9–14)

- | | |
|-------------------------------------|---------------------------------|
| (1) Valve of nitrogen bottle | (9) Charging screw |
| (2) Handle | (10) Accumulator cover |
| (3) Filling adaptor | (11) Diaphragm |
| (4) Gauge | (12) Accumulator body |
| (5) Bleeder valve | (13) Seal ring |
| (6) Check valve | (14) Protective cap (not shown) |
| (7) Hose, approximately 3 m (10 ft) | |
| (8) Reducing nipple (24.32-14WFG) | |

Troubleshooting

Before troubleshooting, determine whether the problem is in the tool, the hoses, or the power source. Substitute a tool, hoses, or power source known to be in good working order to eliminate the item that is not operating.

If the problem is in the tool, refer to the troubleshooting table below. If the problem is in the power source, refer to the troubleshooting section of the power source instruction manual.

Problem	Probable Cause	Probable Remedy
Tool does not operate.	Improper power source.	Verify that the power source meets the specifications.
	Hydraulic fluid level low.	Check the fluid level. Check system for leaks.
	Incorrect hydraulic fluid viscosity.	Use hydraulic fluid with the correct viscosity.
Tool operates slowly or erratically.	Hydraulic fluid cold.	Allow fluid to warm to the operating temperature. Actuate the tool intermittently to reduce the warming time.
	Power source not adjusted correctly.	Refer to the power source operator's manual. Set the flow and pressure to correspond with the tool.
	Hydraulic fluid level low.	Check the fluid level. Check system for leaks.
	Air in the hydraulic system.	Refer to the power source manufacturer's instructions for removing air from the system.
	Incorrect hydraulic fluid viscosity.	Use hydraulic fluid with the correct viscosity.
Tool feels hot.	Hydraulic fluid level low.	Check the fluid level. Check for leaks.
	Incorrect hydraulic fluid viscosity.	Use hydraulic fluid with the correct viscosity.
	Hydraulic fluid dirty.	Refer to the power source owner's manual for procedure to replace hydraulic oil and filter.
Strike rate is normal; blow energy is weak.	Low accumulator gas pressure.	Return tool to an authorized Fairmont service center.
	Broken accumulator diaphragm.	Return tool to an authorized Fairmont service center.

Illustration—Main

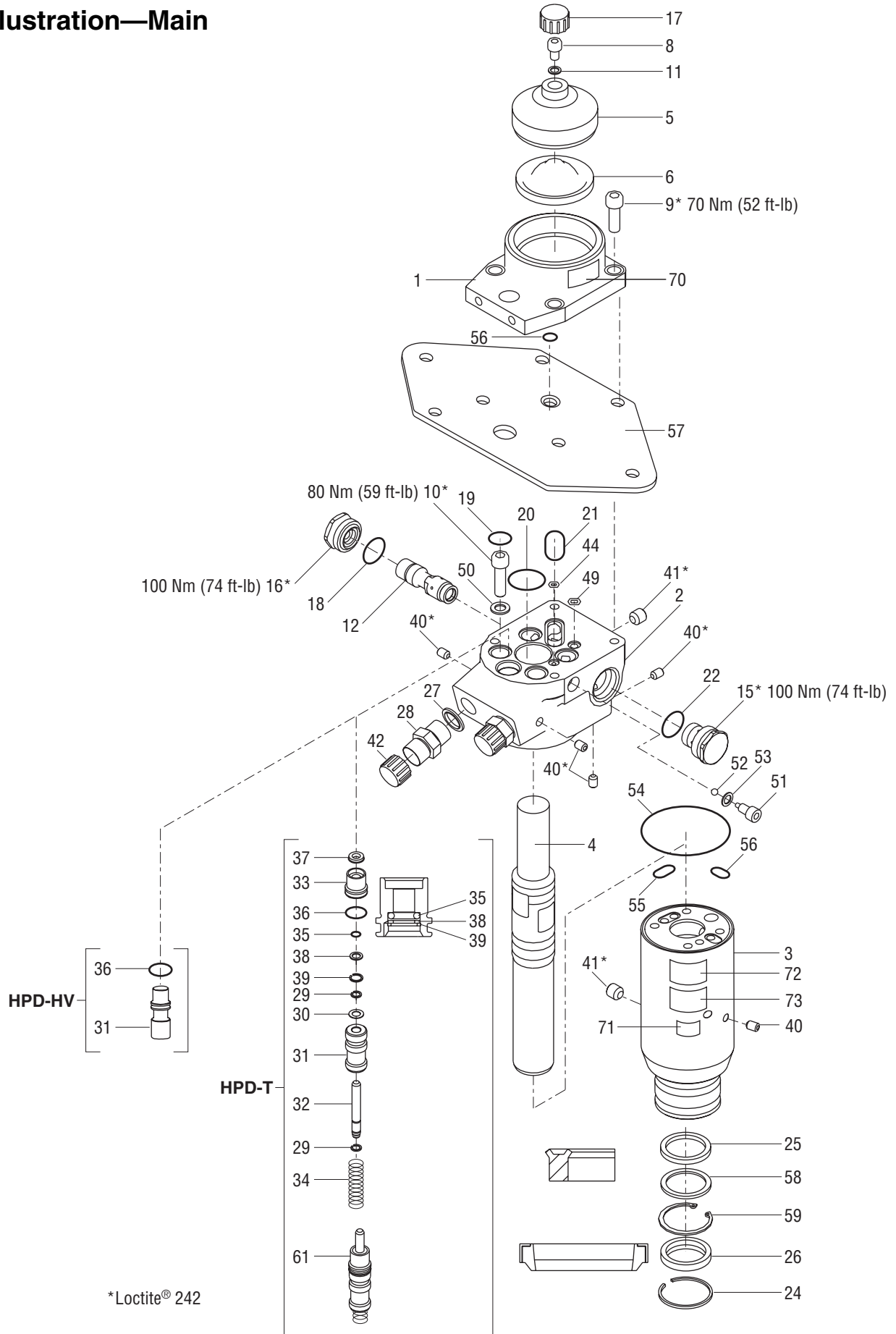

Parts List—Main

Key	Part No.	Description	Qty	Key	Part No.	Description	Qty
1	50022083	Accumulator body	1	35	50022490	O-ring, Ø8.3x2.4	1
2	50022130	Valve housing	1	36*	50022512	O-ring, Ø16.3x2.4	1
3	50024027	Cylinder	1	37	50022520	Seal, Ø8/Ø14x3.5/5	1
4	50028987	Striking piston	1	38	50022539	Backup ring	1
5	50022164	Accumulator cover	1	39*	50022547	Seeger spring ring	1
6	50022172	Diaphragm	1	40	50022555	Fitting, 02 KRG	6
8	50022180	Charging screw	1	41	50022563	Fitting, 04 KRG	3
9	50022202	Screw, M10x35	4	42	50022741	Protective cap, 1/2" (HPD-T)	2
10	50022202	Screw, M10x35	4	42A	50028731	Protective cap, 3/4" JIC (HPD-HV)	2
11*	50022210	Seal ring, Ø8/Ø12x1	1	44*	50022768	O-ring, Ø6x2	1
12	50024710	Spool	1	49*	50022784	O-ring, Ø8x2	1
15	50022253	Guide socket	1	50	50022814	Backup washer	4
16	50022261	Spool socket	1	51	50022822	Screw	1
17*	50022270	Protective cap, M24x1.5	1	52	50022830	Check valve ball	1
18*	50022288	O-ring, Ø24x1.5	1	53*	50022849	Seal ring, Ø9/Ø14x1	1
19*	50022296	O-ring, Ø18x2	4	54*	50022857	O-ring, Ø82x1.5	1
20*	50022300	O-ring, Ø30x2	1	55*	50022881	O-ring, Ø16x1.5	1
21*	50022318	O-ring, Ø32x2	1	56*	50022890	O-ring, Ø13x1.5	2
22*	50022326	O-ring, Ø25x1.5	1	57	50028995	Top plate	1
24*	50022334	Locking ring	1	58*	50022962	Backup washer	1
25*	50022342	Seal, Ø32/Ø40x6	1	59*	50023063	Locking ring	1
26*	50022350	Seal, Ø32/Ø45x7/10	1	61	50023152	Trigger valve, complete (HPD-T)	
27*	50022369	Seal ring, 1/2"	2	Decals			
28	50022377	Adapter, 08-08 (HPD-T)	2	70	50110764	Decal, accumulator	1
28A	50028766	Adapter, 08-12 (HPD-HV)	2	71	50490095	Decal, warning	1
29	50022385	Seeger spring ring	2	72	50463268	Decal, Fairmont	1
30	50022407	Shim, PS 8x14x0.5	1	73	50109499	Plate, identification	1
31	50022415	Trigger spool (HPD-T)	1	Kits			
31A	50028820	Trigger cartridge (HPD-HV)	1	*	5028782	Seal kit (includes items marked with an asterisk)	
32	50022431	Trigger rod	1				
33	50022458	Packing gland	1				
34	50022474	Spring	1				

Illustration and Parts List—Handles, Hoses, and Remote Control Valve

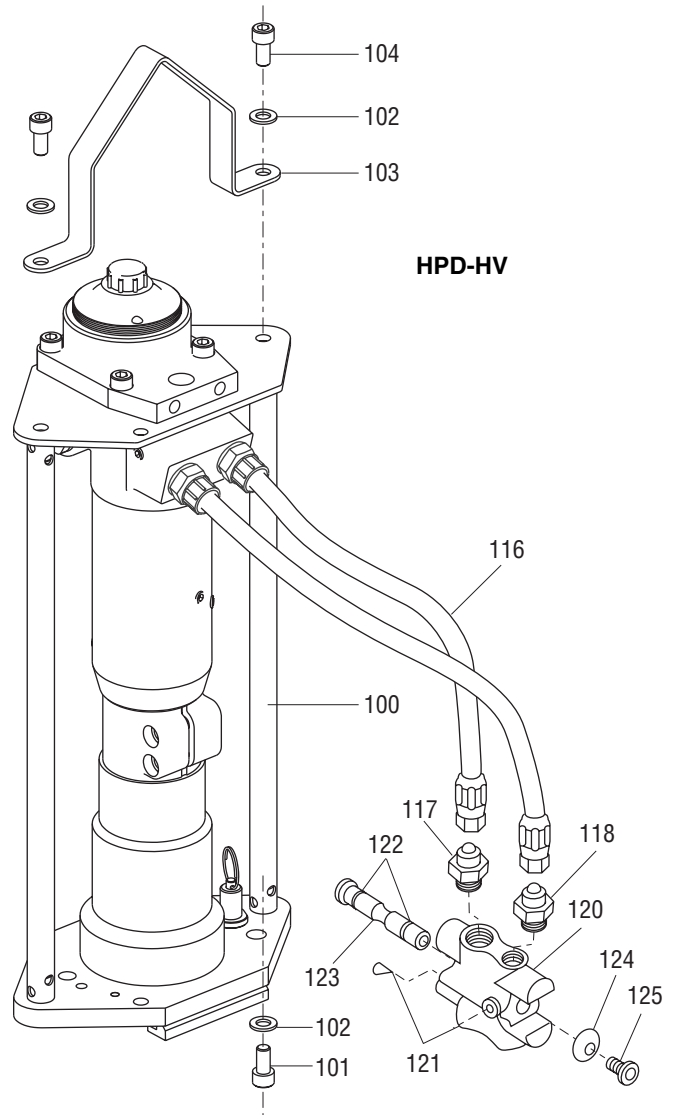
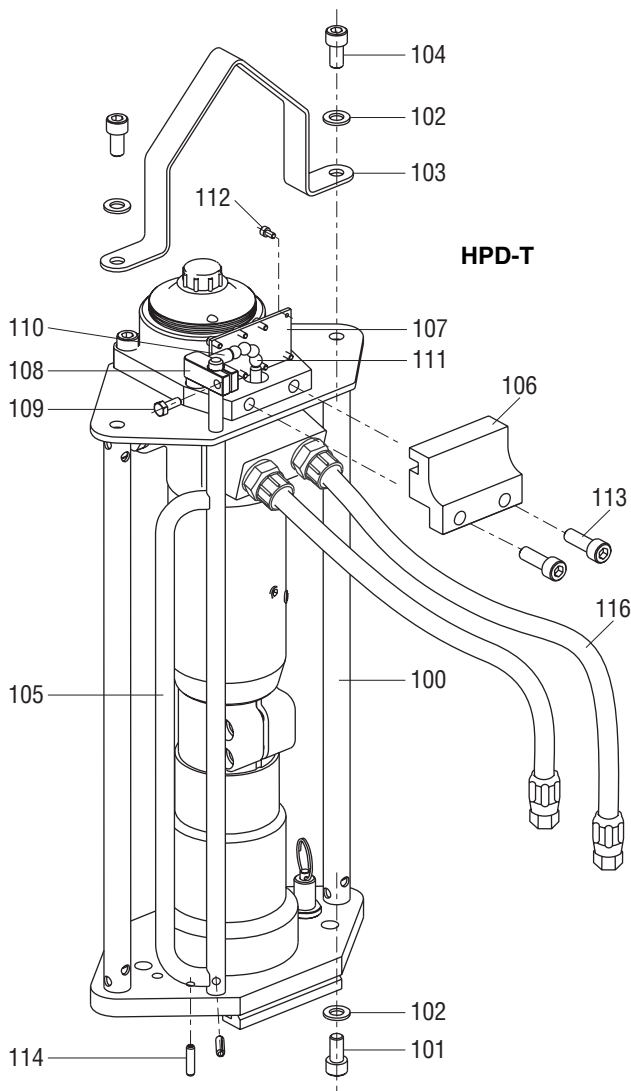

Key	Part No.	Description	Qty
Tube Handles and Lifting Bracket			
100	50030264	Handle W.A.	2
101	50028740	Screw, M10x20	2
102	50028758	Washer, Ø10	4
103	50030272	Lifting bracket.....	1
104	50028774	Screw, M10x20	2
105	50031090	Trigger bar W.A.	1
106	50031953	Trigger housing	1
107	50032003	Trigger cover	1
108	50032054	Trigger lever	1
109	50032070	Screw, M16x15	1
110	50032089	Dowel pin, Ø10x26	1
111	F011341	Ball, Ø3/8"	4
112	50032097	Screw, M5x8	4
113	50022199	Screw, M10x30	2
114	50023535	Roll pin, Ø6x24	2

Key	Part No.	Description	Qty
Hoses			
116	50109138	Whip hose, 12" (HPD-T)	2
116A	50028715	Whip hose, 15" (HPD-HV)	2
117	F013516	Adapter	1
118	F019509	Adapter	1
Remote Control Valve (HPD-HV)			
	111952	Control valve, complete	
120	111953K	Valve body	1
121	F021673	Pipe plug, 1/16"	2
122	F015257	O-ring, .437 x .562 x .062-68	2
123	113418	Spool	1
124	106576	Button	2
125	F018627	Screw, cap, #10-24 x .500, flat head	2

**Illustration and Parts List—
Nose Part**

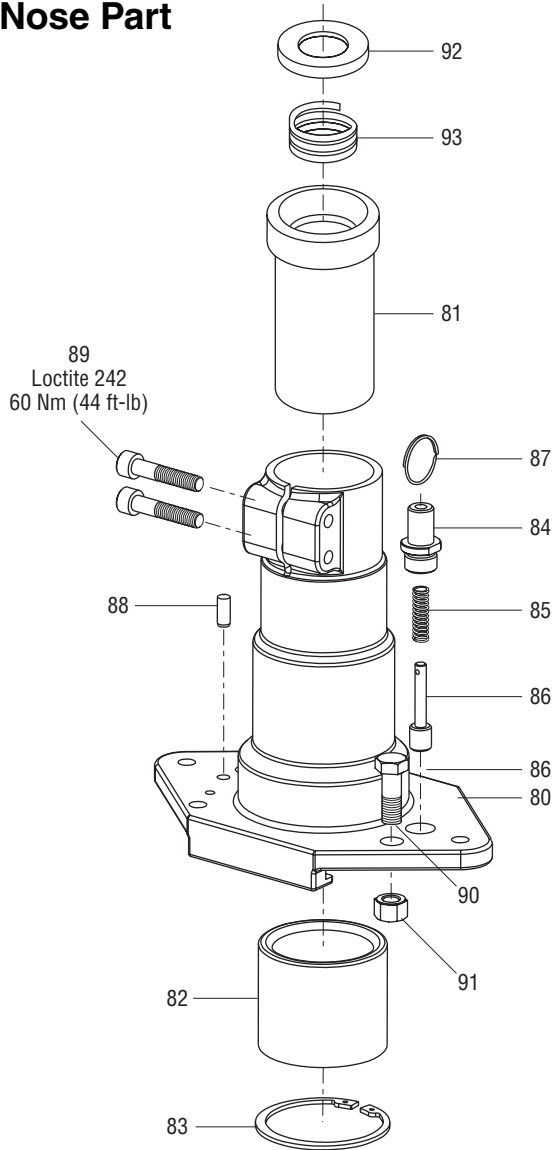

Accessories

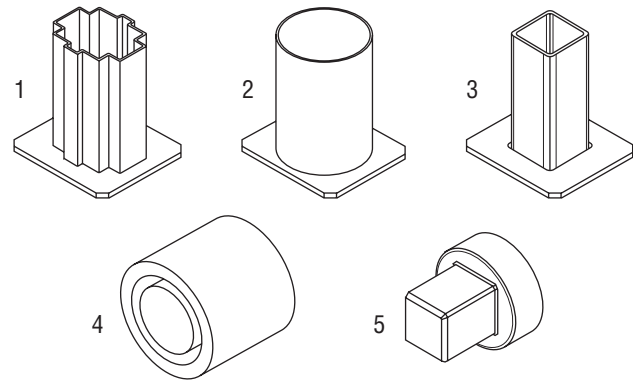

Key	Part No.	Description	Qty
1	49532	Adapter, universal	1
2	49533	Adapter, round, 3.80" inside dia.	1
3	49534	Adapter, square, 2.12"	1
4	136704	Drive cap for 2" round post	1
5	50032372	Adapter, square, 1.75"	1
	50032364	Adapter, square, 2"	1

Key	Part No.	Description	Qty
	50028812	Nose part, complete	
80	50029002	Nose part	1
81	50029010	Anvil	1
82	50029029	Anvil bushing	1
83	50031031	Locking ring	1
84	50030191	Pin housing	1
85	50030221	Compression spring	1
86	50030248	Pin	1
87	50030280	Split ring	1
88	50031023	Dowel pin	1
89	50023756	Screw, M10x55	2
90	50048015	Screw, M12x35	1
91	50048023	Nut, M12	1
92	52022621	Washer	1
93	52022622	Anvil spring	1



USA 800-435-0786 Fax: 800-451-2632
 815-397-7070 Fax: 815-397-1865
 Canada 800-435-0786 Fax: 800-524-2853
 International +1-815-397-7070 Fax: +1-815-397-9247

4455 Boeing Drive • Rockford, IL 61109-2988 • USA • 815-397-7070
 An ISO 9001 Company • Greenlee Textron Inc. is a subsidiary of Textron Inc.

www.greenlee.com