

TSP-SG0001BK 15X9FT RECTANGULAR TRAMPOLINE W/ENCLOSURE AND LADDER

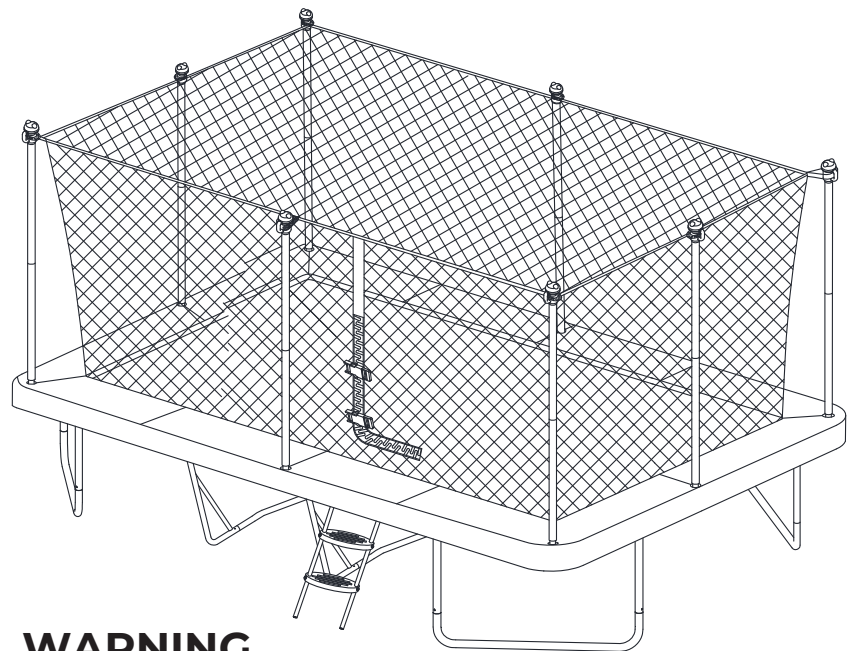

WARNING

- YOU MUST THOROUGHLY READ AND UNDERSTAND THE INSTRUCTIONS IN THIS MANUAL, BEFORE ASSEMBLING AND USING THIS TRAMPOLINE.
- SAVE THIS MANUAL FOR FUTURE REFERENCE.
- MAXIMUM WEIGHT OF THE USER SHALL NOT EXCEED 220LBS (100KG).
- DO NOT ALLOW MORE THAN ONE PERSON ON THE TRAMPOLINE AT A TIME.
- DO NOT ALLOW YOUNG CHILDREN TO USE UNLESS SUPERVISED BY AN ADULT.

WARNING

CHOKING HAZARD - Small Parts
Not for children under 3 years
The product is to be assembled
by an adult.

Global Customer Service

USA / CA — ✉ support@teamson.com

+1(770) 246-4898

Mon - Fri 9 AM - 4 PM EST



EU / UK — ✉ support@teamson.co.uk

+44(0)1952-916-050

Mon - Thur 9 AM - 5 PM GMT

Fri 9 AM - 4 PM GMT



ASIA — 深圳办公室：

✉ sales_ec@teamson.com

+86(0755)8885-3558.分机号108

Mon - Sat 9 AM - 5 PM GMT+8

台北辦公室：

✉ support@teamson.com.tw

+886(2)2556-6268

Mon - Fri 9 AM - 5 PM GMT+8



AU — ✉ support@teamson.com.au

ENGLISH WARNING! Not suitable for children under 3 years, as there is a choking hazard from swallowable small parts. Assembly should be carried out by an adult. Prior to assembly this package contains sharp edges and sharp points. Keep away from children until assembled. Please remove all packaging attachments before giving this item to your child. Please keep this information for possible future correspondence.

ČESKY UPOZORNĚNÍ! Výrobek není vhodný pro děti do 3 let. Obsahuje drobné části, hrozí nebezpečí udušení. Montáž musí provádět dospělý. Design a barvy výrobků mohou být změněny bez předchozího upozornění. Před prvním použitím odstraňte všechny obaly z dosahu dětí. Tyto informace uschovejte pro případné budoucí použití.

CROATIA UPOZORENJE! Igračka nije prikladna za djecu mlađu od tri godine zbog malih dijelova gušenje opasnost. Skupština mora biti izvedena od strane odrasle osobe. Varijacije u boji i dizajnu, mi se pridržavamo. Uklonite sve ambalaze prije prve uporabe. Sačuvajte ove informacije za bilo koji naknadno dopisivanje.

DUTCH WAARSCHUWING! Niet geschikt voor kinderen beneden 3 jaar omdat er gevaar voor verstikking door inslikbare kleine voorwerpen bestaat. De montage van dit speelgoed moet door een volwassene worden uitgevoerd. Kleuren en versieringen kunnen afwijken. Verwijder alle verpakkingselementen voordat u dit speelgoed aan uw kind geeft. Bewaar deze verpakking voor een eventuele latere correspondentie.

FRENCH ATTENTION! Ce produit est inadapté aux enfants de moins de 3 ans, car il existe le risque d'étouffement causé par les petites pièces qui peuvent s'avaler. Le montage doit être effectué par un adulte. Nous nous réservons le droit d'apporter des modifications aux couleurs et à la conception. Retirer l'emballage et les attaches plastiques avant de donner cet article à votre enfant. Nous vous prions de conserver cette information pour une éventuelle utilisation ultérieure.

GERMAN ACHTUNG! Nicht geeignet für Kinder unter 3 Jahren, da Erstickungsgefahr durch verschluckbare Kleinteile besteht. Der Zusammenbau muss von einem Erwachsenen durchgeführt werden. Abweichungen in Farbe und Gestaltung behalten wir uns vor. Bitte entfernen Sie alle Verpackungsteile vor dem erstmaligen Gebrauch. Bitte bewahren Sie diese Information für evtl. spätere Korrespondenz auf.

HUNGARY FIGYELMEZTETÉS! Nem alkalmas 3 év alatti gyermekek, mert a kis alkatrészek fulladást okozhatnak. A szerkezetet úgy kell elvégezni egy felnőtt. Szín és design fenntartva. Kérjük, távolítsa el a csomagolást az első használat előtt. Kérjük, őrizze meg ezt az információt bármilyen későbbi vonatkozó levelezést.

ITALIAN AVVERTENZA! Non adatto a bambini al di sotto dei 3 anni, visto che vi è rischio di asfissamento causato dall'ingerimento di componenti piccoli. Il montaggio di questo prodotto deve essere fatto sotto di un adulto. I colori e le decorazioni possono variare. Per favore conservare la confezione nel caso ci sia bisogno di spedire indietro qualcosa.

POLSKI OSTRZEŻENIE! Produkt nie nadaje się dla dzieci poniżej 3-ego roku życia. Ze względu na małe części istnieje ryzyko zadławienia, poknięcia, itd. Montaż wózka powinien odbywać się pod nadzorem osoby dorosłej. Przed pierwszym użyciem proszę usunąć wszystkie elementy opakowania. Kolory i wzory mogą się różnić. Należy zachować opakowanie w przypadku konieczności wymiany.

PORTUGAL AVISOS! Guarde esta informação para futura referência. Não apropriado para crianças com menos de 3 anos de idade devido à existência de peças pequenas e bordas/pontas afiadas. Este brinquedo deve ser montado por um adulto. As cores e o conteúdo podem ser algo diferentes do mostrado na caixa. Retire todo elemento de embalagem antes de entregar o produto à criança.

SLOVENIJA OPOZORILO! Ni primerno za otroke mlajše od treh let. Nevarnost zadušitve. Majhni deli. Sestav mora opraviti odrasla oseba. Razlike v barvo in obliko, si pridržujemo pravico do. Prosimo, odstranite vse pakirni material pred prvo uporabo. Prosimo, da shranite te informacije za vsak nadaljnji korespondenci.

SLOVENSKY UPOZORNENIE! Výrobok nie je vhodný pre deti do 3 rokov. Obsahuje drobné časti, hrozí nebezpečenstvo udusenía. Montáž musí vykonávať dospelý. Design a farby výrobkov môžu byť zmenené bez predchádzajúceho upozornenia. Pred prvým použitím odstráňte všetky obaly z dosahu detí. Tieto informácie uschovejte pre prípadné budúce použitie.

SPAIN ADVERTENCIA! Guarde esta información para futura referencia. No apto para niños menores de 3 años por contener piezas pequeñas, contiene bordes/puntas afiladas. Este juguete debe ser montado por un adulto. Los colores y el contenido pueden ser algo diferentes de lo mostrado en la caja. Retire todos los elementos de embalaje antes de dar el artículo a su hijo.

SVENSKA VARNING! Inte lämplig för barn under 3 år på grund av små delar kvävningrisk. Monteringen måste utföras av en vuxen. Färg och design är reserverade. Ta bort allt förpackningsmaterial före första användningen. Vänligen behålla denna information för eventuell senare korrespondens på.

繁體 警告! 需由成年人完成組裝。本產品不適於3歲以下兒童使用。本包裝包含細小零件，完成組裝前，請慎防兒童吞食小零件，避免窒息危險，且可能有鋒利邊緣及尖角，所以組裝完成前應置於兒童不能觸及之處，並遠離火源。

簡體 警告! 需要成年人組裝。不適合三歲以下的兒童使用。完成組裝前，本包裝包含細小零件，可能引發窒息危險；以及包含鋒利邊緣和尖角，所以完成組裝前，請確保其遠離兒童。



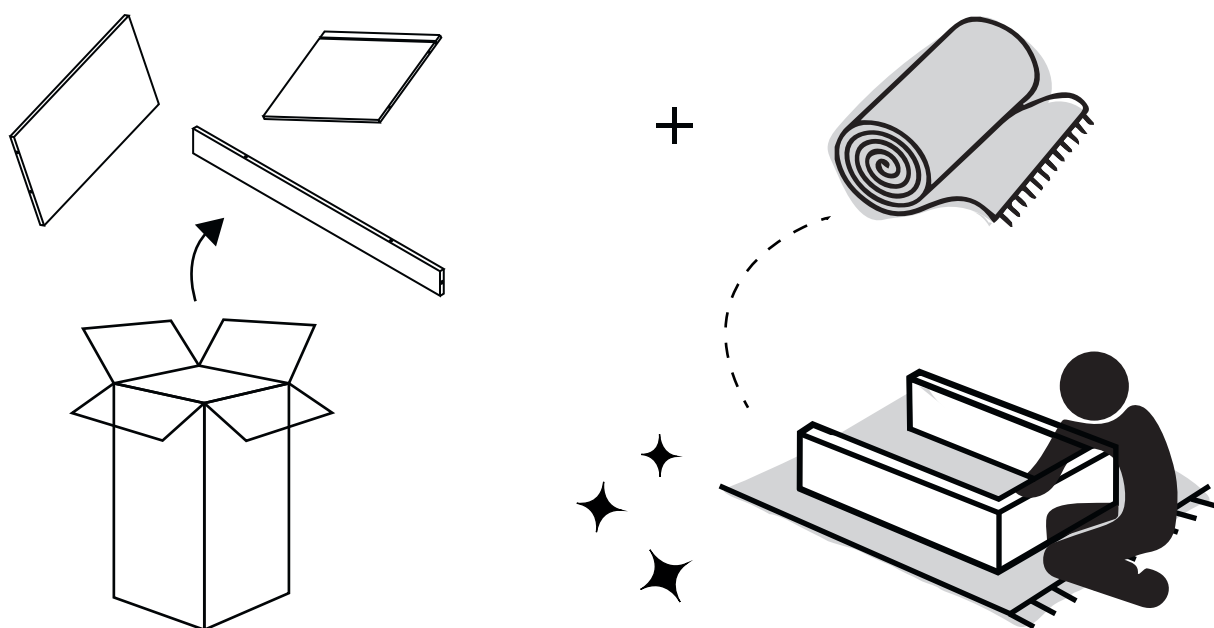
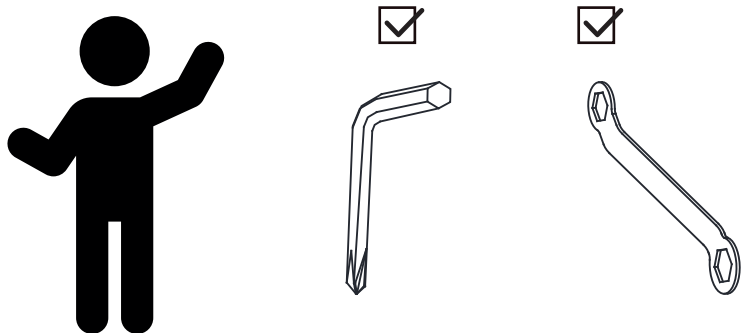

** Got questions?

Please have your product code (on the first page of this instruction, e.g. TSP-SG0001BK) and the order number ready, give us a call or email us through our customer care support!

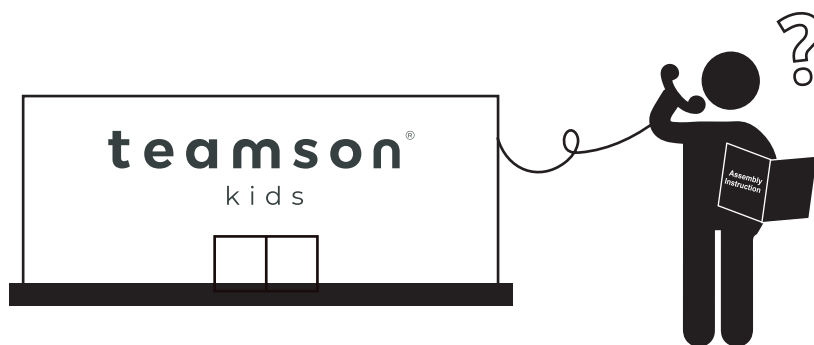

We are always ready to assist you!

CARE INSTRUCTIONS

To clean your product, use mild soap and water on a damp cloth, Do not use window cleaners or cleaning abrasives as they will scratch the surface and could damage the protective coating.

Thank you for purchasing this product. We hope that you will enjoy it. It will take a little time to assemble it. Please take it as an exercise in assembling this product. It is not unusual for you to take more than an hour to assemble this product; so please be patient and enjoy this process with a friend.



WARNING

MAXIMUM WEIGHT OF THE USER SHALL NOT EXCEED 220LBS (100KG).

TRAMPOLINE ASSEMBLY AND MOVING

Select a location where you want the trampoline permanently prior to assembly.



MOVING THE TRAMPOLINE

If you need to move the trampoline, two or three people are required. When moving, lift the trampoline slightly off the ground and keep it horizontal to the ground. For any type of other movement, you should disassemble the trampoline.



We strongly recommend that you do not use the trampoline without an enclosure. If you find the trampoline is being used without an enclosure, stop the user and immediately purchase and install the enclosure. Lateral clearance is essential. Place the trampoline away from walls, structures, fences and other play areas. Maintain a clear space on all sides of the trampoline.



Do not allow children to play or jump on the trampoline when it's windy or during tornado season. Wind can lift up this trampoline and cause serious injury or death.

INTRODUCTION

Before you begin using this trampoline, be sure to carefully read all the information provided to you in this manual. Just like any other type of physical recreational activity, participants can be injured. To reduce the risk of injury, be sure to follow appropriate safety rules and tips.

- ✧ Misuse and abuse of this trampoline is dangerous and can cause serious injury!
- ✧ Trampolines, being rebounding devices, propel the performer to unaccustomed heights and into a variety of body movements.
- ✧ Always inspect the trampoline before each use for worn mats, loose or missing parts.
- ✧ Proper assembly, care and maintenance of product, safety tips, warnings, and proper techniques in jumping and bouncing are all included in this manual. All users and supervisors must read and familiarize themselves with these instructions. Anybody who chooses to use this trampoline must be aware of their own limitations in regards to performing various jumps and bounces with this trampoline.

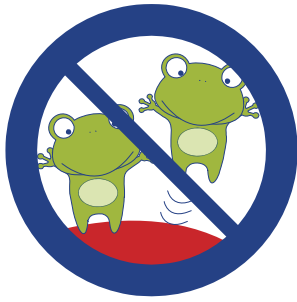

NO MORE THAN ONE PERSON AT A TIME ON THE TRAMPOLINE! MULTIPLE JUMPERS INCREASE THE RISK OF INJURY SUCH AS BROKEN HEAD, NECK, LEG OR BACK.



PARALYSIS OR DEATH CAN RESULT IF YOU LAND ON YOUR HEAD OR NECK! DO NOT PERFORM SOMERSAULTS (FLIPS) AS THIS WILL INCREASE YOUR CHANCES OF LANDING ON YOUR HEAD OR NECK!

ALWAYS CONSULT A PHYSICIAN BEFORE PERFORMING ANY KIND OF PHYSICAL ACTIVITY

- Adequate overhead clearance is essential. A minimum of 24ft from ground level is recommended. Provide clearance for wires, tree limbs, and other possible hazards.
- Lateral clearance is essential. Place the trampoline away from walls, structures, fences, and other play areas.
- Maintain a clear space of 2.5 meters on all sides of the trampoline. For safe use of the trampoline, please be aware of the following when selecting a place for your trampoline.
- Place the trampoline on a level surface before use; illumination may be required for shady areas and indoor areas.
- Secure the trampoline against unauthorized and unsupervised use.
- Remove any obstructions from beneath the trampoline.
- The owner and supervisors of the trampoline are responsible to make all users aware of practices specified in the use instructions.
- Do not attempt or allow somersaults. Landing on the head or neck can cause serious injury, paralysis or death, even when landing in the middle of the bed.
- Do not allow more than one person on the trampoline. Use by more than one person at the same time can result in serious injury.
- Use trampoline only with mature, knowledgeable adult supervision.
- For additional information concerning the trampoline equipment, contact the manufacturer.
- Only for domestic use and outdoor use.
- Not suitable for children under 3 years. Small parts. Choking hazard. Long cord. Strangulation hazard.
- Maximum weight of the user shall not exceed 220lbs (100kg).
- Only one user. Collision hazard.
- Adult supervision required.
- No somersaults.
- Always jump in the middle of the mat.
- All nuts and bolts must be checked for tightness and if necessary must be retightened.
- All spring-loaded (pit pin) joints must be checked to see that they are still intact and cannot become dislodged during play.
- Check all coverings for bolts and sharp edges and replace them if necessary.
- If self-locking nuts are used, it should be noted that these are only suitable for one assembly and must therefore be replaced.
- Information regarding the expiry of the enclosure.
- Trampolines over 20in. (51 cm) tall are not recommended for use by children under 6 years of age.
- Inspect the trampoline before each use. Make sure the frame padding is correctly and securely positioned. Replace any worn, defective, or missing parts.
- Climb on and off the trampoline. It is a dangerous practice to jump from the trampoline to the floor or ground when dismounting, or to jump onto the trampoline when mounting. Do not use the trampoline as a springboard onto other objects.
- Stop bounce by flexing knees as feet come in contact with the trampoline bed. Learn this skill before attempting others.
- Learn fundamental bounces and body positions thoroughly before trying more advanced skills. A variety of trampoline activities can be carried out by performing the basic fundamentals in various series and combinations, performing one fundamental after another, with or without feet bounces between them.
- Avoid bouncing too high. Stay low until bounce control and repeated landing in the center of the trampoline can be accomplished. Control is more important than height.
- Focus eyes on the trampoline. This will help control bounce.
- Avoid bouncing when tired. Keep turns short.
- Properly secure the trampoline when not in use. Protect it against unauthorized use. If a trampoline ladder is used, the supervisor should remove it from the trampoline when leaving the area to prevent unsupervised access by children under 6 years of age.

- Ladder lets young children climb onto trampoline.
- Keep objects away which could interfere with the performer. Maintain a clear area around the trampoline.
- Do not use the trampoline while under the influence of alcohol or drugs.
- For information concerning skill training, contact a certified trampoline instructor.
- Bounce only when the surface of the bed is dry. Wind or air movement should be calm to gentle. The trampoline must not be used in gusty or severe winds.
- Always start your jump at the center of the trampoline mat. When you land more than 1ft away from the center of the trampoline mat, stop your jump immediately!! Restart your jump at the center of the trampoline mat.
- Read all instructions before using the trampoline, warnings and instructions for the care, maintenance, and use of this trampoline are included to promote safe, enjoyable use of this equipment.
- Do not eat while jumping
- Instructions that the trampoline is not intended to be buried into the ground.

TRAMPOLINE PLACEMENT

The minimum overhead clearance required is 24 feet (7.3 meters). In terms of horizontal clearance, please ensure that no hazardous objects are near the trampoline such as tree limbs, other recreational objects (i.e. swing sets, swimming pools), electrical power wiring, walls, fences, etc. For safe use of the trampoline, please be aware of the following when selecting a place for your trampoline:

- Make sure it is placed on a flat and level surface.
- The area is well-lit.
- There are no obstructions beneath the trampoline.
- When not in use, the trampoline shall be secured against unauthorized use.
- The surface of the jump bed shall be dry. Do not jump on wet bed.
- Wind or air movement shall be calm and gentle. Do not use trampoline in gusty or severe wind.
- Person in charge and responsible for use of the trampoline shall make users aware of practice specified on this manual. Person in charge shall be a qualified adult. This person shall always be present, when trampoline is in use.
- Do not place trampoline on concrete floor, hard ground surface (i.e. rock) or slippery surface. Do not use indoors.

WARNING

If you do not follow these guidelines, you increase the risk of someone getting injured.

This trampoline was designed and manufactured with quality materials and craftsmanship. If proper care and maintenance are provided, it will provide all jumpers with years of exercise, fun, and enjoyment as well as reduce the risk of injury. Please follow the guidelines listed below:

This trampoline is designed to withhold a certain amount of weight and use. Please make sure that only one person is using the trampoline at any one time. Also, the person should weigh less than 220 pounds; jumpers should either wear socks, gymnastics shoes, or be barefoot when using the trampoline.

Please be aware that street shoes or tennis shoes should NOT be worn while using the trampoline. In order to prevent the trampoline mat from getting cut or damaged please do not allow any pets onto the mat. Also, jumpers should remove all sharp objects from their pockets prior to using the trampoline.

All objects should be kept off the trampoline mat at all times.

Always inspect the trampoline before each use for worn, abused or missing parts. A number of conditions could arise that may increase your chances of getting injured. Please be aware of:

- Punctures, frays, tears or holes worn in the bed or frame padding
- Missing, improperly positioned or insecurely attached frame padding
- Sagging trampoline mat
- Loose stitching or any kind of deterioration of the mat
- Bent or broken frame parts (legs and/or rails)
- Broken, missing or damaged springs

- Damaged, missing or insecurely attached frame pad
- Protrusions of any types (especially sharp typed) on the frame, springs or mat or suspension
- Always close the net opening before practice
- Empty pockets and hands before practice
- Do not exit the mat by a jump
- Limit the time of continuous usage (make regular stops)

IF YOU FIND ANY OF THE PREVIOUS CONDITIONS OR ANYTHING ELSE THAT YOU FEEL COULD CAUSE HARM TO ANY USER, THE TRAMPOLINE SHOULD BE DISASSEMBLED OR SECURED FROM USE UNTIL THE CONDITION(S) HAS BEEN RESOLVED.

WINDY CONDITIONS

In severe wind situations, the trampoline can be blown about. If you expect windy weather conditions, the trampoline should be moved to a sheltered area or be disassembled. Another option is to tie the round, outside portion (top frame) of the trampoline to the ground using ropes and stakes. To ensure security, at least four (4) tie downs should be used. Do not just secure the legs of the trampoline to the ground because they can be pulled out of the frame sockets.

TRAMPOLINES OVER 20 IN. (51CM) TALL ARE NOT RECOMMENDED FOR USE BY CHILDREN UNDER 6 YEARS OF AGE.

DO NOT USE INDOORS.

IMPORTANT!

READ IT! Failure to follow these instructions to ensure proper operational condition of your trampoline may lead to serious injury or death. Do not allow more than one person on the trampoline at a time.

1. Maintenance of Trampoline Enclosure Net and Pad

Enclosure net and pad are prone to wear and tear like tires on a car. Gradual deterioration of the material will occur, the speed of which will depend on the level of exposure to UV rays, airborne pollution, and outdoor weather conditions such as rain and wind.

The net and pad need to be properly maintained and checked by following the Maintenance Schedule set out in these instructions. When the material shows any signs of weakness, you must stop using the trampoline immediately, properly store the trampoline and restrict access by users until a new replacement net or pad is properly installed.

2. Maintenance Requirement for Enclosure Net

Your trampoline enclosure netting is manufactured with UV resistant material. Despite this the netting is exposed to the outdoor elements including sunlight, wind, rain and wildlife.

The net surrounding the trampoline must be checked prior to each use. This includes, but is not limited to inspecting the net for cracks, excess wear, brittleness, stretching, all connections and for overall integrity. The net must be immediately replaced if it shows any signs of wear, damage, being stretched, cracked, loose, brittle or otherwise loses any integrity. The following Maintenance Schedule must be followed:

1 to 3 Months	3 to 6 Months	6 to 12 Months
Thorough inspection for UV damage and prior to every use for net.	Thorough inspection for UV damage and prior to every use for net, net hanger and straps.	Thorough inspection before every use on net, net hanger, straps, zippers, ties and strings. Replace after 12 months or earlier.

IT IS RECOMMENDED THAT THE NET BE REPLACED ON A YEARLY BASIS OR EARLIER UNDER NORMAL USE, EVEN IF IT DOES NOT SHOW ANY VISIBLE SIGNS OF DAMAGE.

INFORMATION ON USE OF THE TRAMPOLINE

- Initially, you should get accustomed to the feel and bounce of the trampoline. The focus must be on the fundamentals of your body position and you should practice each bounce (the basic bounces) until you can do each skill with ease and control.
- **To break a bounce, all you need to do is flex your knees sharply before they come in contact with the mat of the trampoline.** This technique should be practiced while you are learning each of the basic bounces. The skill of braking should be used whenever you lose balance or control of your jump.

- Always learn the simplest bounce first and be consistent with the control of your bounce before moving on to more difficult and advanced bounces. **A controlled bounce is one when your take off point and landing point is the same spot on the mat.** If you move up to the next bounce without first mastering the previous, you increase your chances of getting injured.

- Do not bounce on the trampoline for extended periods of time because fatigue can increase your chances of becoming injured. Bounce for a brief period of time and then allow others to join in on the fun! Never have more than one person bouncing on the trampoline.

- Jumpers should wear clothing free of drawstrings, hooks, loops or anything that could get caught while using the trampoline/enclosure and result in entanglement or strangulation, or both.

If you are just beginning, you may want to wear long sleeve shirts and pants to protect against scrapes and abrasions until you master correct landing positions and form.

Do not wear hard sole shoes, such as tennis shoes on the trampoline, as this will cause excessive wear on the mat material.

- You should always mount and dismount properly in order to avoid injury. To mount properly, you should **PLACE** your hand on the frame and either step or roll up onto the frame, over the springs, and onto the trampoline mat. You should always remember to place your hands onto the frame while mounting or dismounting. Do not step directly onto the frame pad or grasp the frame pad. To dismount properly, move over to the side of the trampoline and place your hand onto the frame as a support and step from the mat to the ground. Smaller children should be assisted when mounting and dismounting the trampoline.
- Do not bounce recklessly on the trampoline since this will increase your chances of getting injured. The key to safety and having fun on the trampoline is control and mastering the various bounces. Never try to out-bounce another bouncer in terms of height! Never use the trampoline alone without supervision.

ACCIDENT CLASSIFICATION

Mounting and dismounting: Be very careful when getting on and off the trampoline. **DO NOT** mount the trampoline by grabbing the frame pad, stepping onto the springs, or by jumping onto the mat of the trampoline from any object (i.e. a deck, roof, or ladder). This will increase your chances of getting injured! **DO NOT** dismount by jumping off the trampoline and landing on the ground, regardless of the makeup of the ground. If small children are playing on the trampoline, they may need help in mounting and dismounting.



Use of alcohol or Drugs: DO NOT consume any alcohol or drugs when using this trampoline! This will increase your chances of getting injured since these foreign substances might impair your judgments, reaction time, and overall physical coordination.

Multiple Jumpers: If you have multiple jumpers (more than one person on the trampoline at any one time), you increase the chances of getting injured. Injuries could occur when you fly off the trampoline, lose control, collide with the other jumper(s) or land on the springs. Generally, the lightest person on the trampoline will get injured.

Striking the Frame or Springs: When playing on the trampoline, STAY in the center of the mat. This will reduce the risk of getting injured by landing on the frame or springs. Always ensure that the frame pad covers the frame of the trampoline. DO NOT jump or step onto the frame pad directly since it was not intended to support the weight of a person.

Loss of Control: DO NOT try difficult maneuvers, or any maneuver until you have mastered the previous maneuver, or if you are just learning how to jump on a trampoline. If you do, you will increase the risk of getting injured by landing on the frame, springs or off the trampoline completely because you might lose control of your jump. A controlled jump is considered landing on the same spot that you took off from. If you do lose control when you are jumping on the trampoline, bend your knees sharply when you land and this will allow you to regain control and stop your jump.

Somersaults (Flips): DO NOT PERFORM somersaults of any type (backwards or forwards) on this trampoline, if you make a mistake when trying to perform a somersault, you could land on your head or neck. This will increase your chances of getting your neck or back broken, which will result in death or paralysis, even when landing in the middle of the trampoline mat.

Foreign Objects: DO NOT use the trampoline if there are pets, other people, or any objects underneath the trampoline. This will increase the chances of an injury occurring. DO NOT hold any foreign objects in your hand and DO NOT place any objects on the trampoline while anyone is playing on it. Please be aware of what is overhead when you are playing on the trampoline. Tree limbs, wires, or other objects located over the trampoline will increase your chances of getting injured.

Poor Maintenance of Trampoline: A trampoline in poor condition will increase your risk of getting injured. Please inspect the trampoline before each use for bent steel tubes, torn mat, loose or broken springs, and overall stability of the trampoline.

Weather Conditions: Please be aware of the weather conditions when using the trampoline. If the mat of the trampoline is wet, the jumper could slip and injure him or herself. If it is too windy, jumpers could lose control.

Limiting Access: When the trampoline is not in use, always store the access ladder in a secure place so that children cannot play on the trampoline unsupervised.

TIPS TO REDUCE THE RISK ACCIDENTS

Jumper's role in accident prevention

The key here is to stay in control of your jumps. DO NOT move onto more complicated, more difficult maneuvers until you have mastered the basic, fundamental bounce.

Education is also key to safety and very important. Read, understand, and practice all safety precautions and warnings prior to using the trampoline. A controlled jump is when you land and take off from the same location. For additional safety tips and instructions, contact a certified trampoline instructor.

Supervisor's Role in Accident Prevention

Supervisors need to understand and enforce all safety rules and guidelines. It is the responsibility of the supervisor to provide knowledgeable advice and guidance to all jumpers of the trampoline. If supervision is unavailable or inadequate, the trampoline could be stored in a secure place, disassembled to prevent unauthorized use, or covered with a heavy tarp that can be locked or secured with lock or chains. The supervisor is also responsible to ensure that the safety placard is placed on the trampoline and that jumpers are informed of these warnings and instructions.

TRAMPOLINE SAFETY INSTRUCTIONS

JUMPERS

- ◆ Do not use trampoline if you have consumed alcohol or drugs
- ◆ Remove all hard and sharp objects from person before using trampoline
- ◆ You should climb on and off in a controlled and careful manner. Never jump on or off the trampoline and never use the trampoline as a device to bounce onto or into another object.
- ◆ Always learn the basic bounce and master each type of bounce before trying more difficult types of bounces. Review the Basic Skills Section to learn how to do the basics.
- ◆ To stop your bounce, flex your knees when you land on the mat with your feet.
- ◆ Always be in control when you are bouncing on the trampoline. A controlled jump is when you land at the same spot that you took off from. If at any time you feel out of control, try to stop your bouncing.
- ◆ Do not jump or bounce for prolonged periods of time or too high for a number of jumps.
- ◆ Keep your eyes in the mat to maintain control. If you do not, you could lose balance or control.
- ◆ Never have more than 1 person on the trampoline at any one time.
- ◆ Always have a supervisor watching you when you are on the trampoline.

SUPERVISORS

Educate yourself with the basic jumps and safety rules. To prevent and reduce the risk of injuries, enforce all safety rules and ensure that new jumpers learn the basic bounces before trying more difficult and advanced jumps.

- ◆ All jumpers need to be supervised, regardless of skill level or age.

- ◆ Never use the trampoline when it is wet, damaged, dirty, or worn out. The trampoline should be inspected before any jumpers start bouncing on it.
- ◆ Keep all objects that could interfere with the jumper away from the trampoline. Be aware of what is overhead, underneath, and around the trampoline.
- ◆ To prevent unsupervised and unauthorized use, the trampoline should be secured when not in use.

LESSON PLAN

The following lessons are suggested in order to learn basic steps and bounces before moving onto more difficult, complicated bounces. Before actually getting on and using the trampoline, you should read and understand all safety instructions. A complete discussion and demonstration of body mechanics and trampoline guidelines should occur between the supervisor and student as well.

THE BASIC BOUNCE

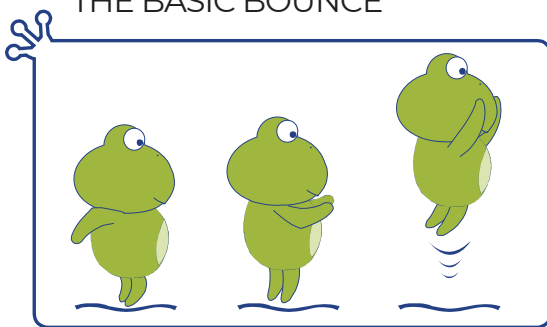

1. Start from the standing position, with your feet having shoulder width apart and with head up and eyes on mat.
2. Swing arms forward and up in a circular motion.
3. Bring feet together while in mid-air and point toes downwards.
4. Keep the feet shoulder width apart when landing on mat.

KNEE BOUNCE

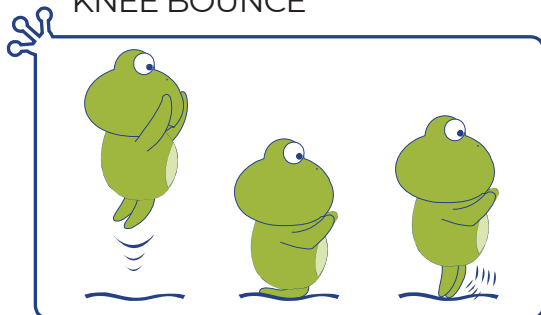

1. Start with the basic bounce and keep it low.
2. Land on knees while keeping your back straight and body erect while using your arms to maintain balance.
3. Bounce back to basic bounce position by swinging arms up.

SEAT BOUNCE

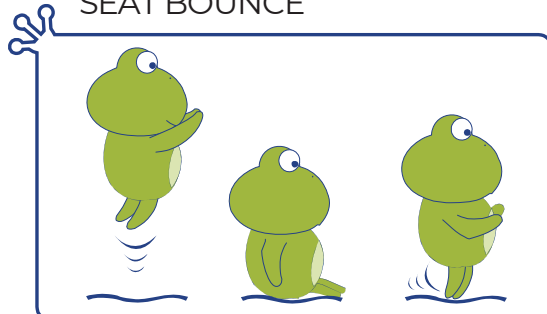

1. Land in a flat sitting position.
2. Place hands on mat besides hips, but do not lock your elbow.
3. Return to erect position by pushing with hands.

FRONT BOUNCE

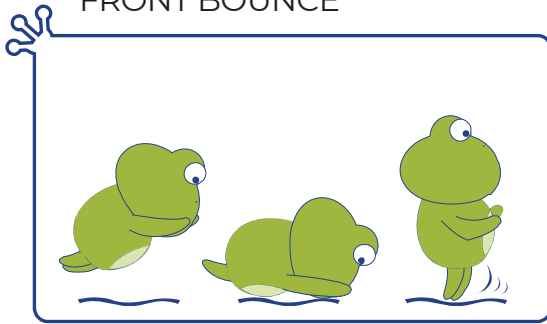

1. Start with a low bounce.
2. Land in prone (face down) position and keep hand and arms extended forward on mat.
3. Push off the mat with arms to return to standing position.

180 DEGREE BOUNCE

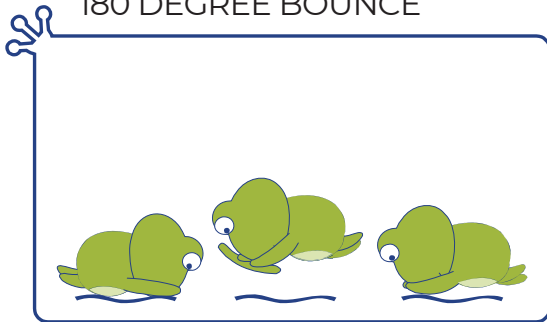

1. Start with the Front Bounce position.
2. Push off with left or right hands and arms (depending on which way you wish to turn).
3. Maintain head and shoulders in the same direction while keeping your back parallel to the mat and your head up.
4. Land in the Prone position and return to standing position.

ALWAYS START YOUR JUMP AT THE BROKEN CIRCLE. WHEN YOU LAND MORE THAN 1FT OR 30.5CM AWAY FROM THE EDGE OF THE BROKEN CIRCLE, STOP YOUR JUMP IMMEDIATELY!!

RESTART YOUR JUMP AT THE OF BROKEN CIRCLE.

ALWAYS START YOUR JUMP AT THE CENTER OF THE TRAMPOLINE MAT. WHEN YOU LAND MORE THAN 1FT OR 30.5CM AWAY FROM THE CENTER OF THE TRAMPOLINE MAT, STOP YOUR JUMP IMMEDIATELY!!

RESTART YOUR JUMP AT THE CENTER OF THE TRAMPOLINE MAT.

ASSEMBLY INSTRUCTIONS

To assemble this trampoline all you need is our special spring loading tool provided with this product. During periods of non-use, this trampoline can be easily disassembled and stored. **Please read the assembly instructions before beginning to assemble the product.**











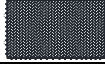

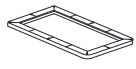

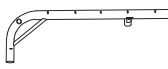

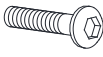
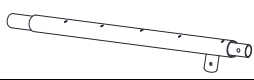



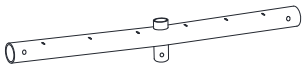















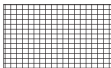

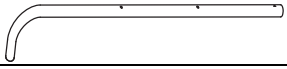

PRIOR TO ASSEMBLING

Please refer to next page for parts descriptions and numbers. The assembly steps use these descriptions and numbers as reference for your convenience.

Make sure that you have all parts listed. If you are missing any parts, please refer to this page for instructions on how to attain any parts.

To prevent any injuries to your hands from pinch points during assembly, **please use protective gloves to protect your hands.**

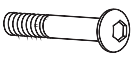
Product Parts

Part No.	Diagram	Quantity	Part No.	Diagram	Quantity
1		1	23		18
2		1	24		14
3		2	25		4
4		2	26		10
5		2	27		1
6		2	A		8
7		2	B		8
8		2	C		8
9		2	D		8
10		8	E		8
11		4	F		8
12		4	G		8
13		2	H		8
14		2	I		16
15		80	J		1
16		4	K		9
17		16	M		1
18		16	L-1		2
19		1	L-2		2
20		1	L-3		4
21		1	L-4		4
22		4	L-5		4

Exploded Drawing

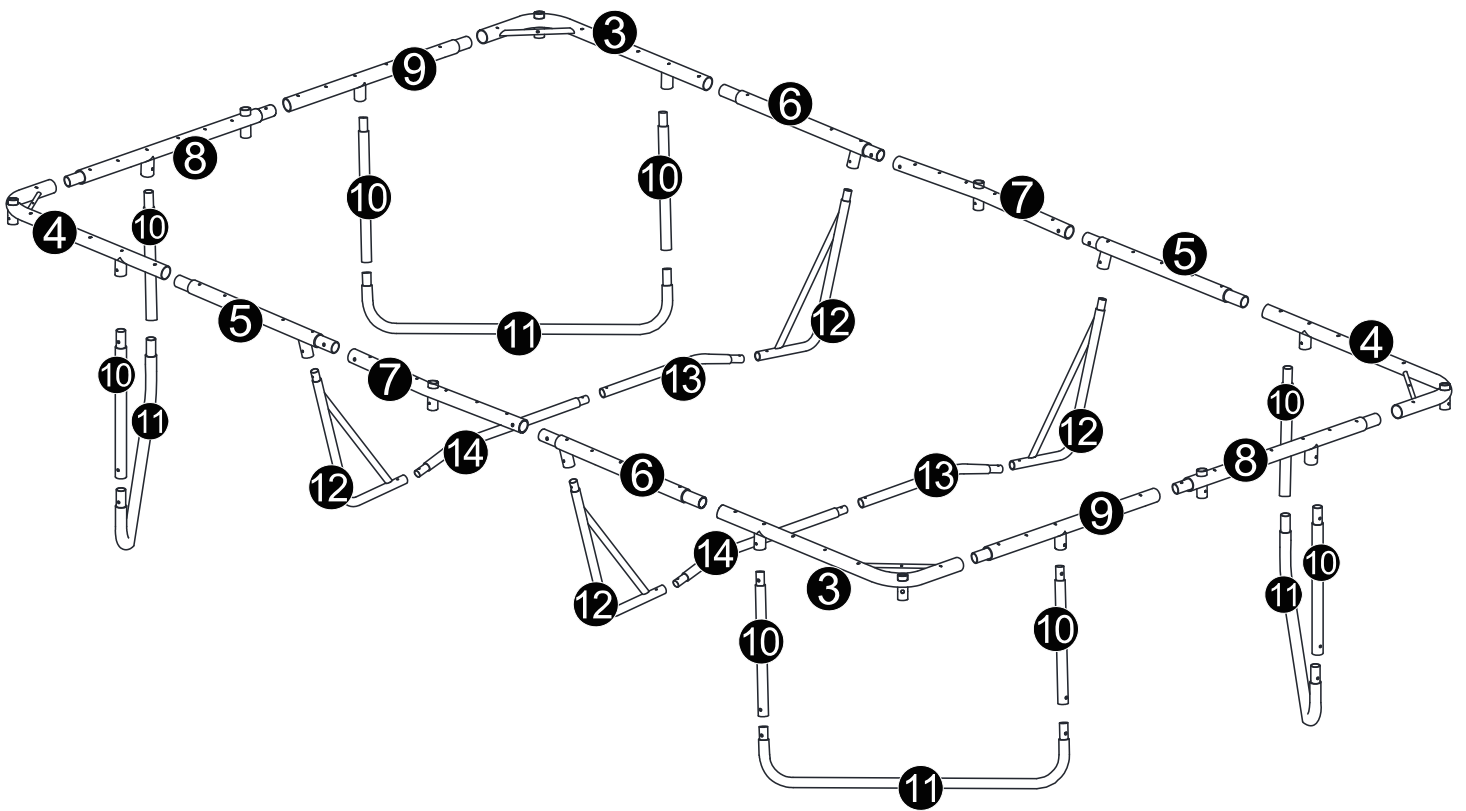

Assembly Instruction

STEP 1

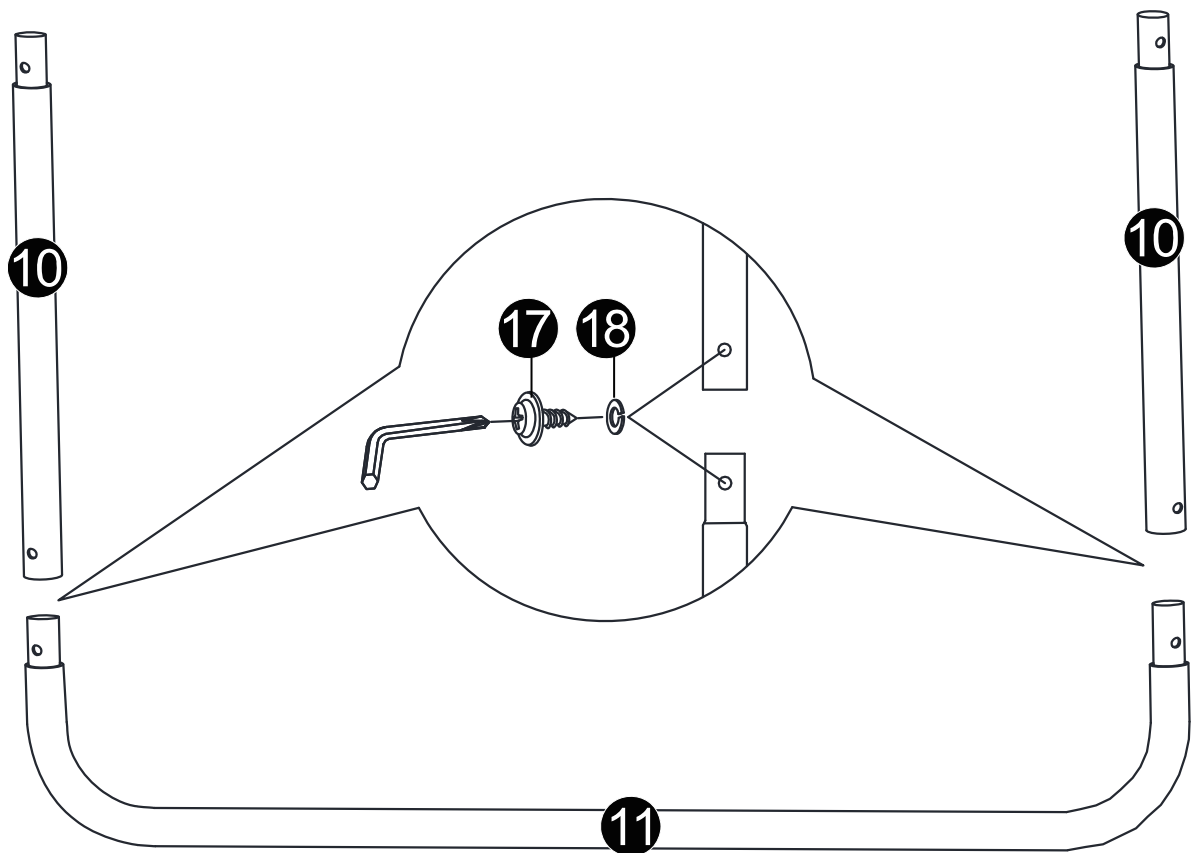

Assembly Instruction

STEP 2

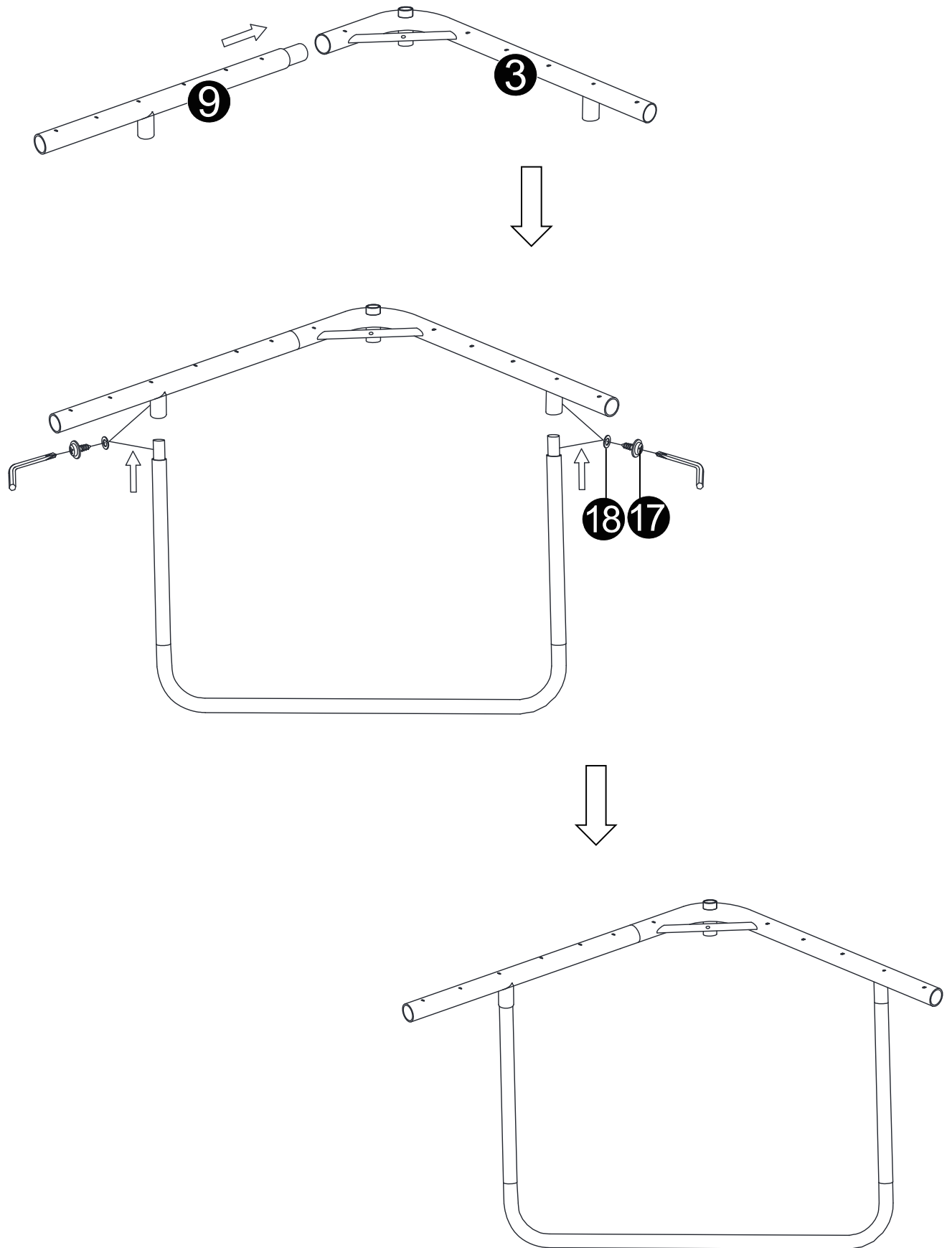

Assembly Instruction

STEP 3

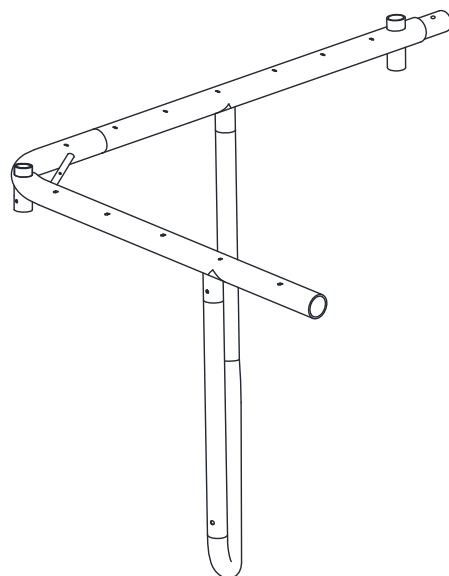
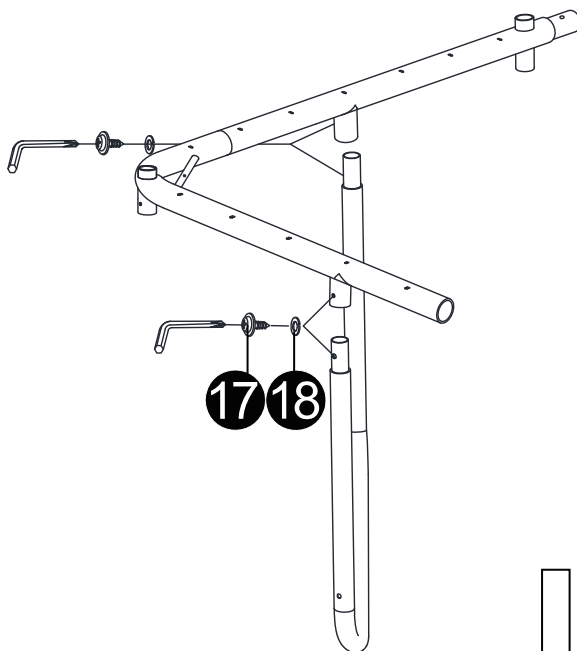
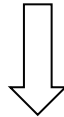
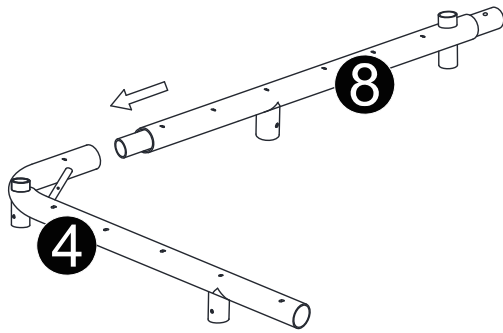

Assembly Instruction

STEP 4

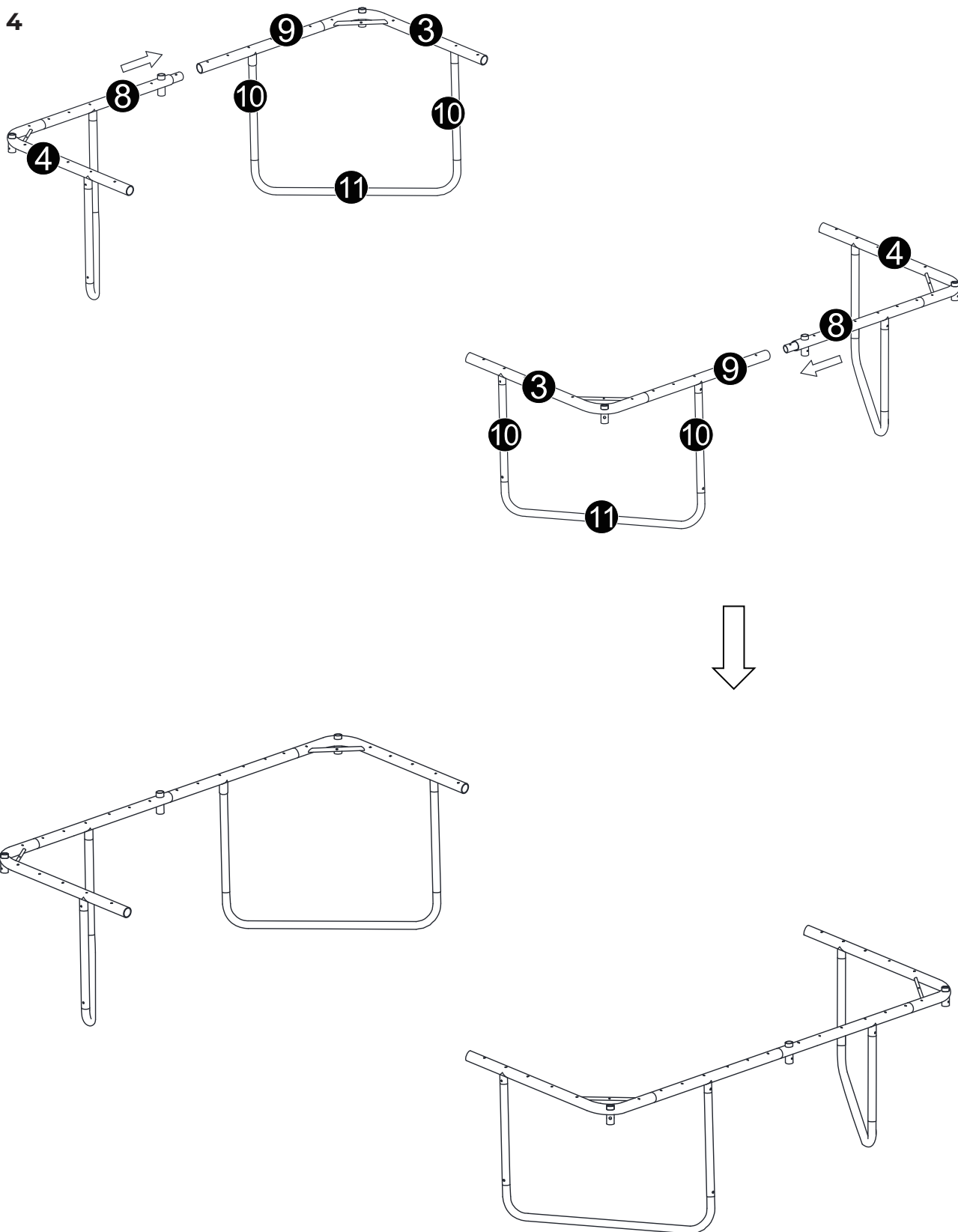

Assembly Instruction

STEP 5

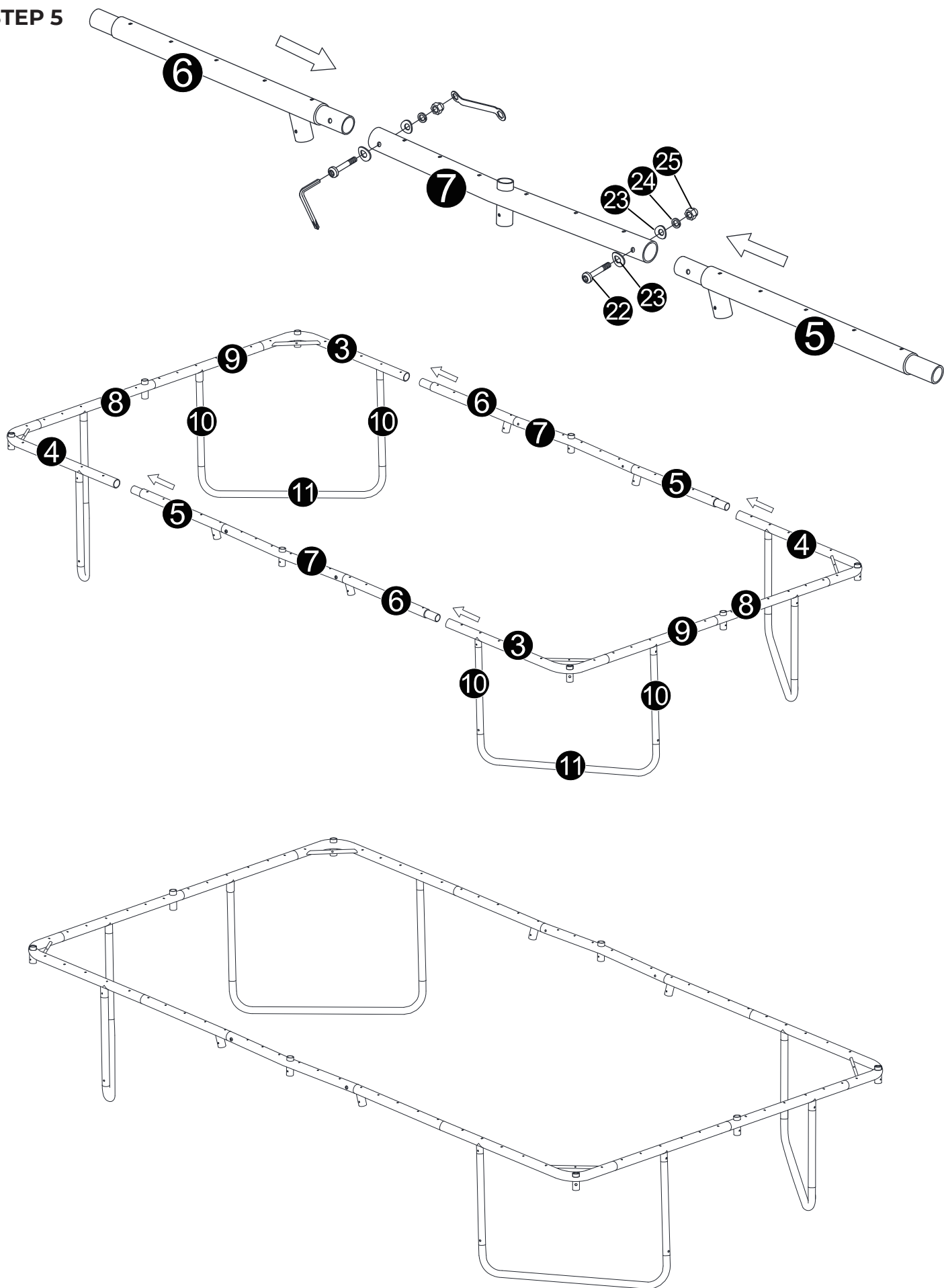

Assembly Instruction

STEP 6

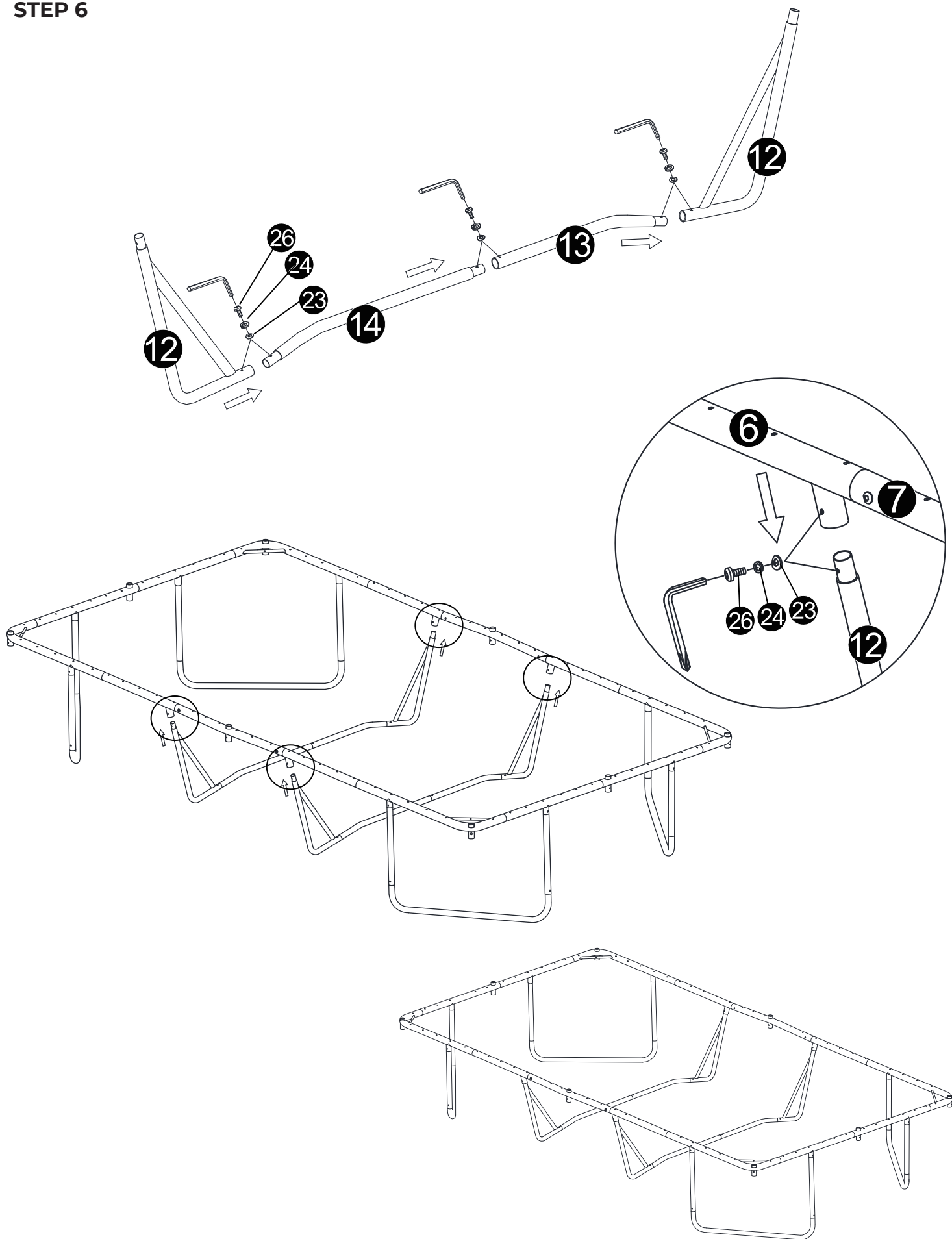

Assembly Instruction

STEP 7-1

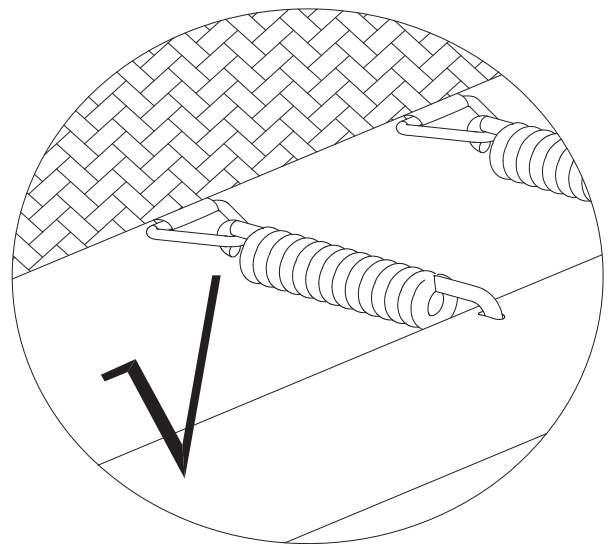
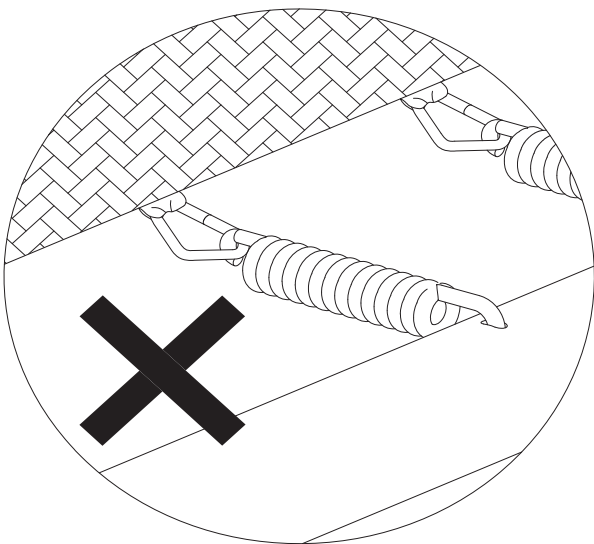
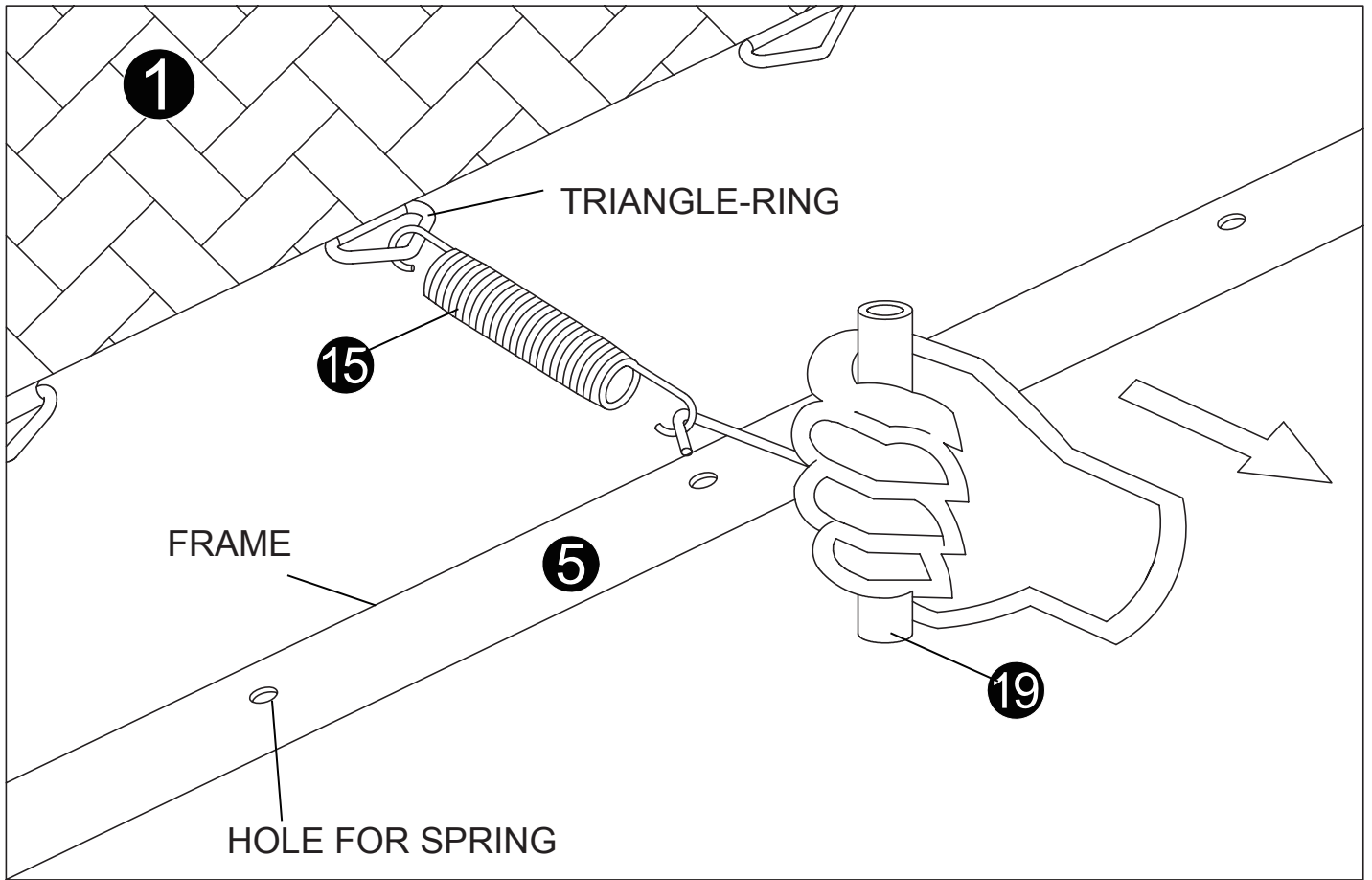

Assembly Instruction

STEP 7-2

NOTE:

When the first spring is in place continue with the next in the numerical order shown on the picture. It is important to follow this instruction carefully to get the right tension for the trampoline mat. If you do not follow this pattern it will be very difficult to assemble the trampoline mat correctly.

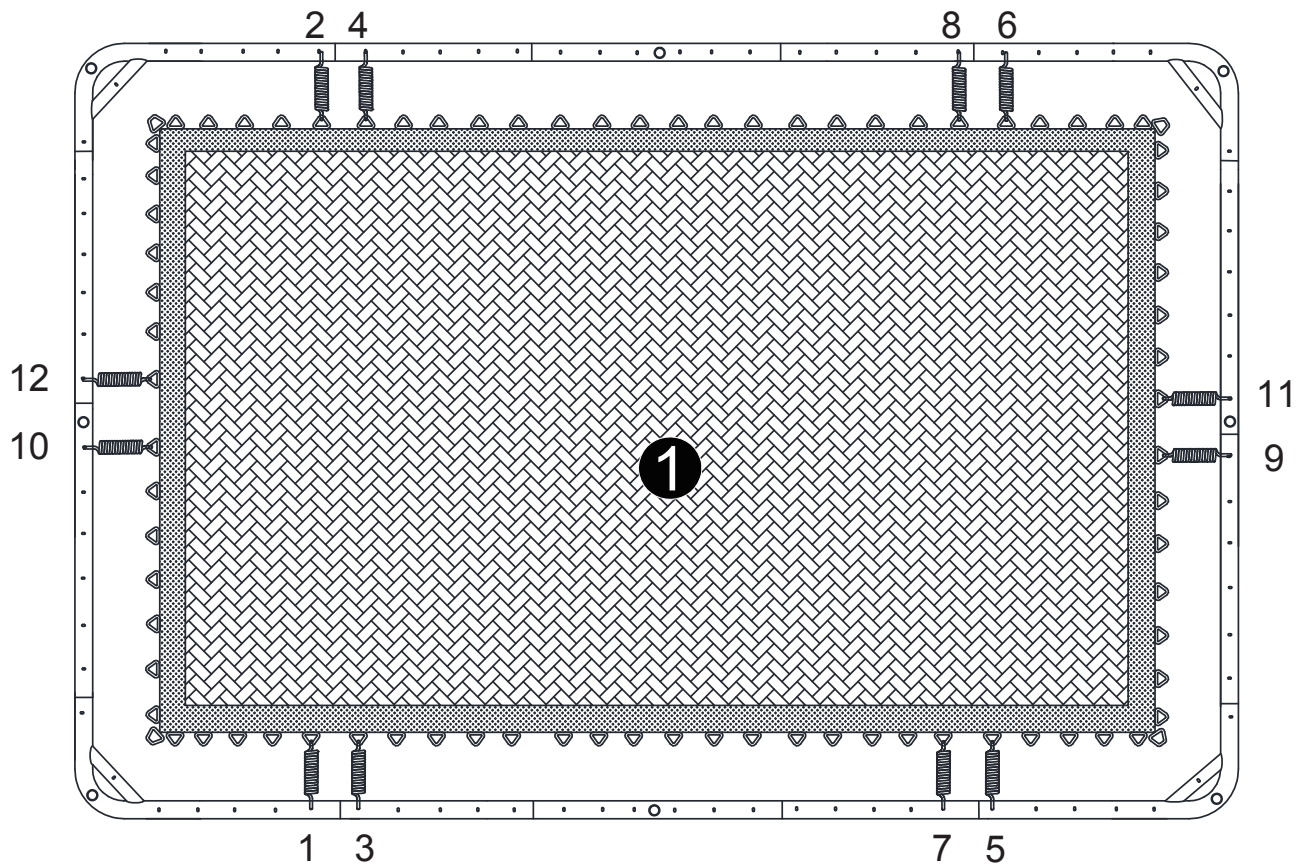

Assembly Instruction

STEP 7-3

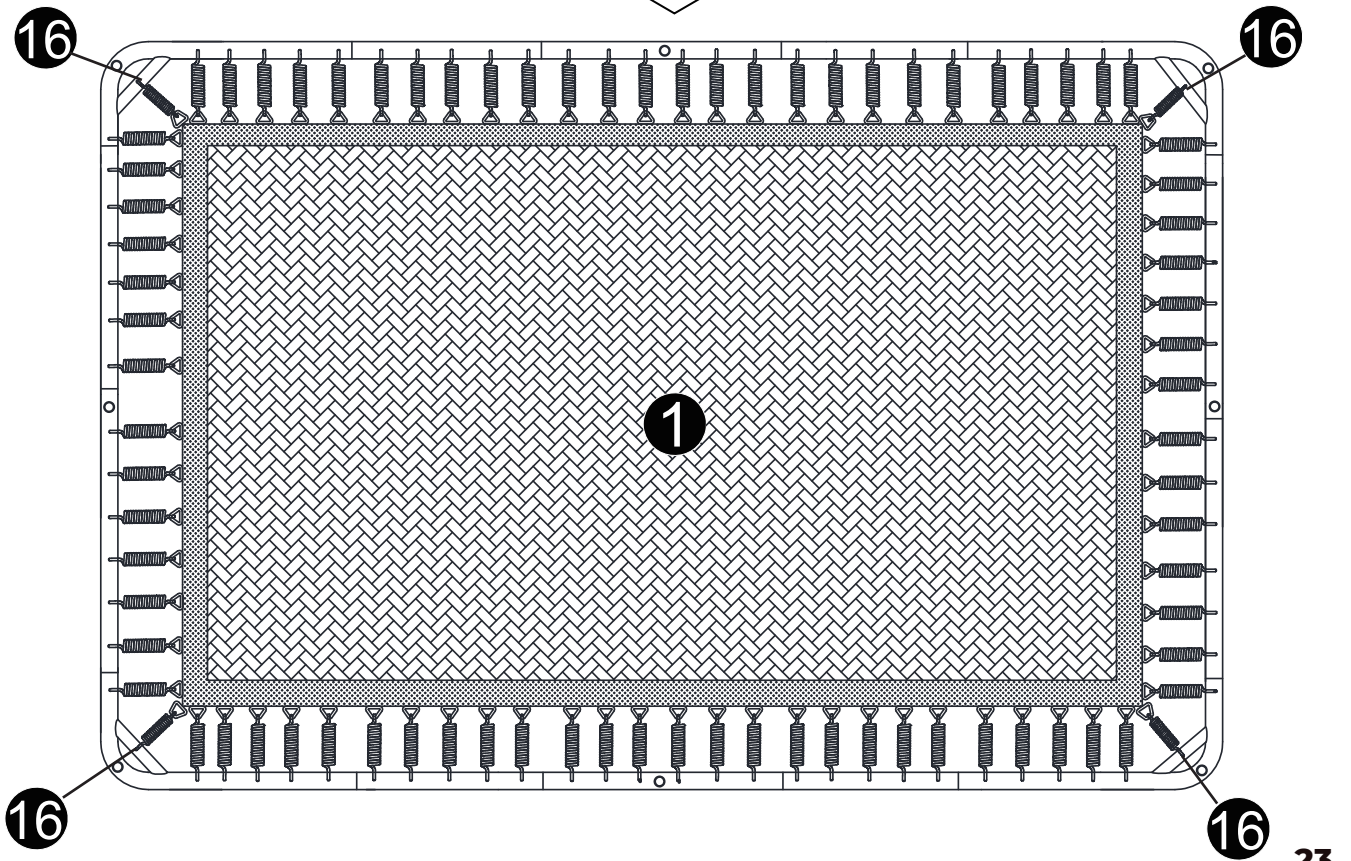
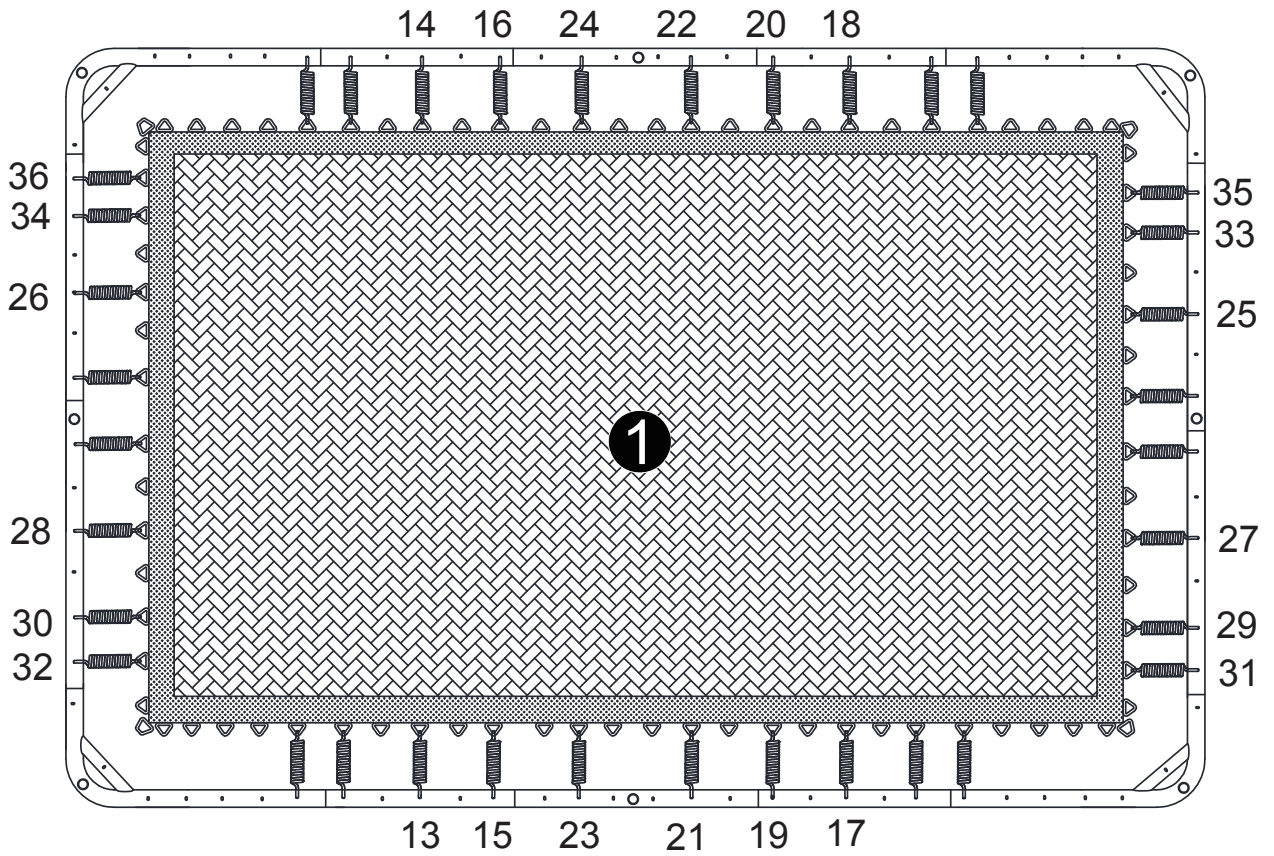

Assembly Instruction

STEP 8

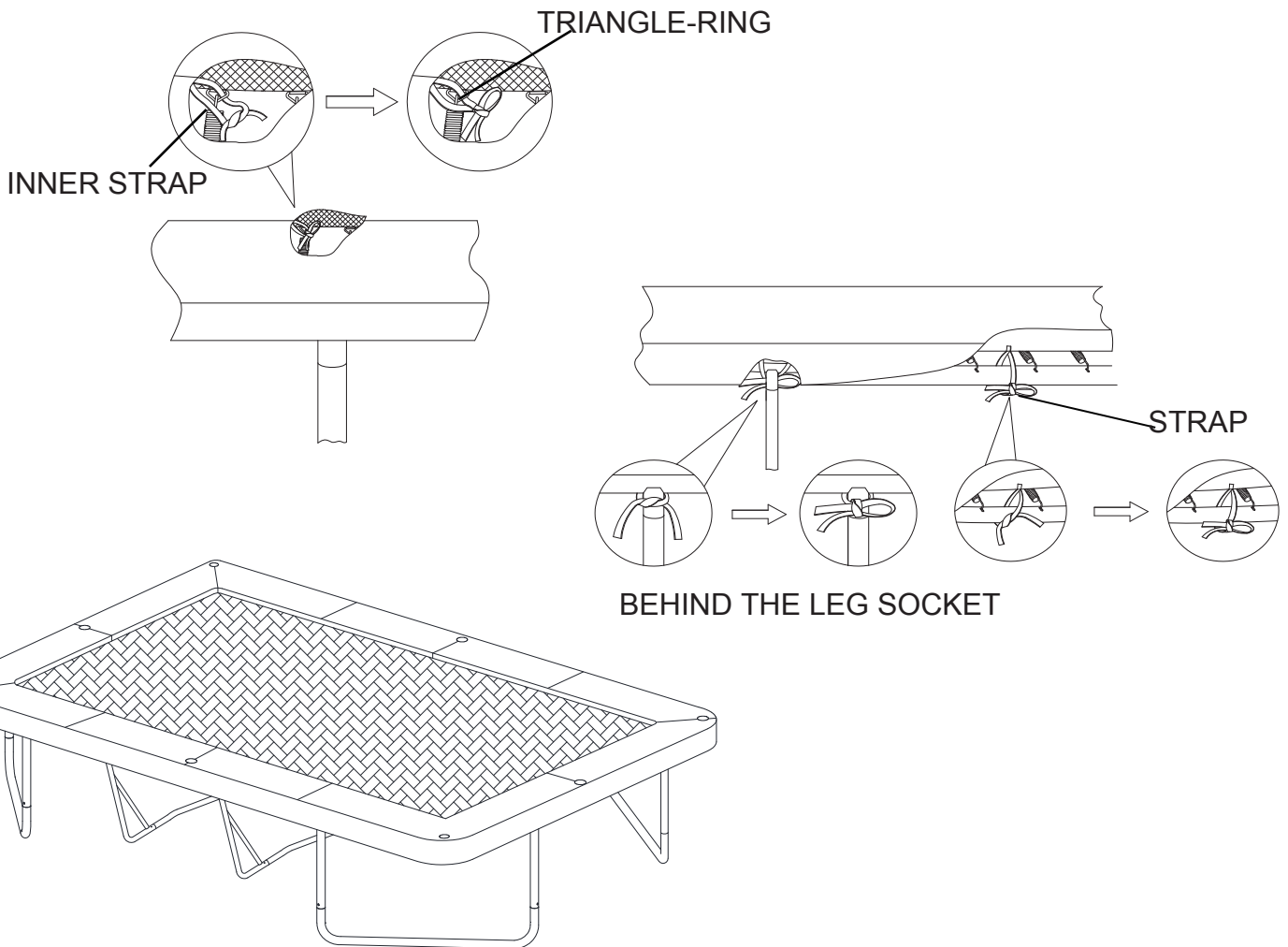
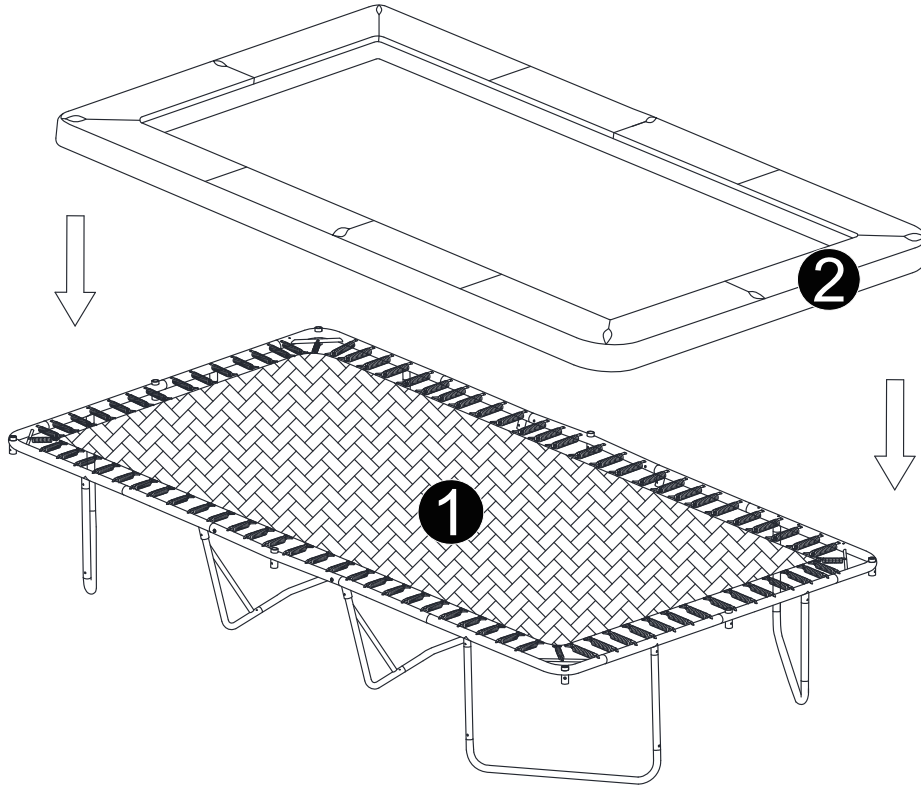

Assembly Instruction

STEP 9

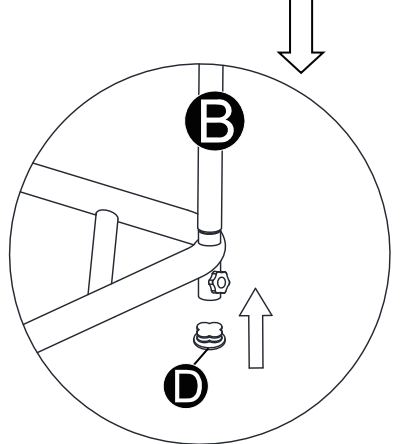
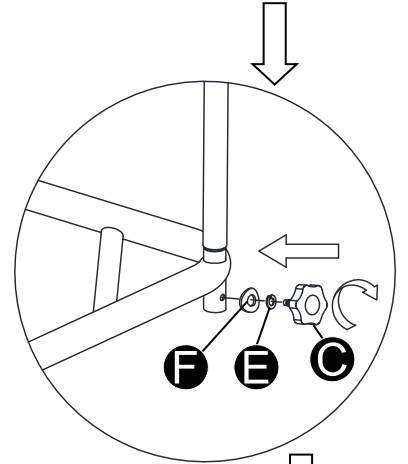
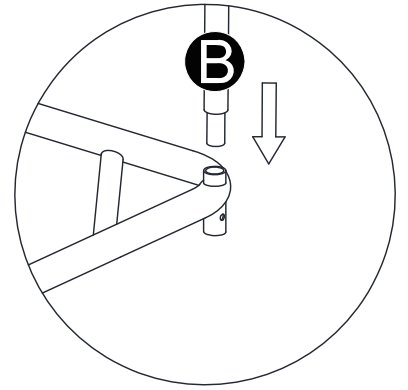
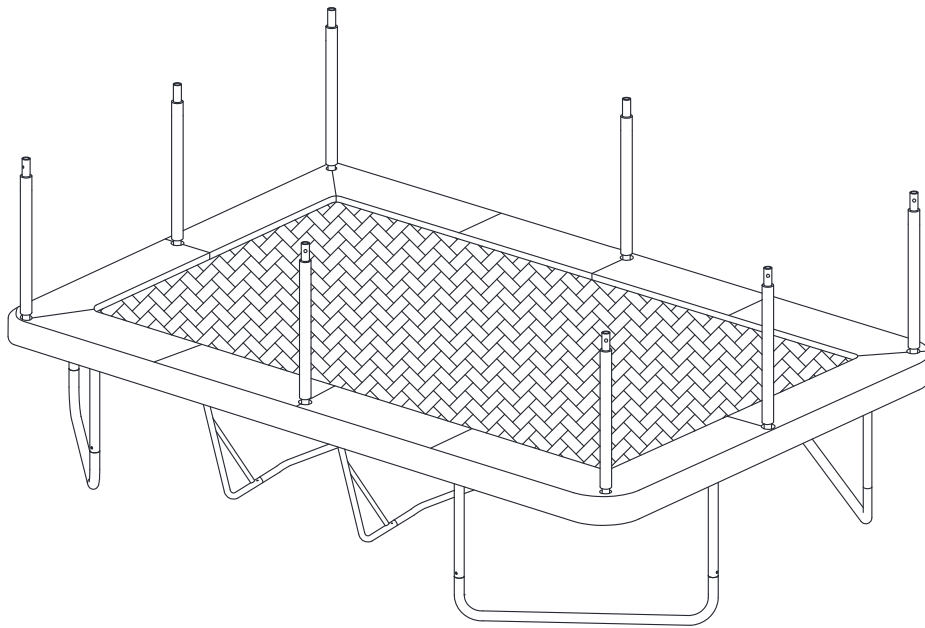

Assembly Instruction

STEP 10

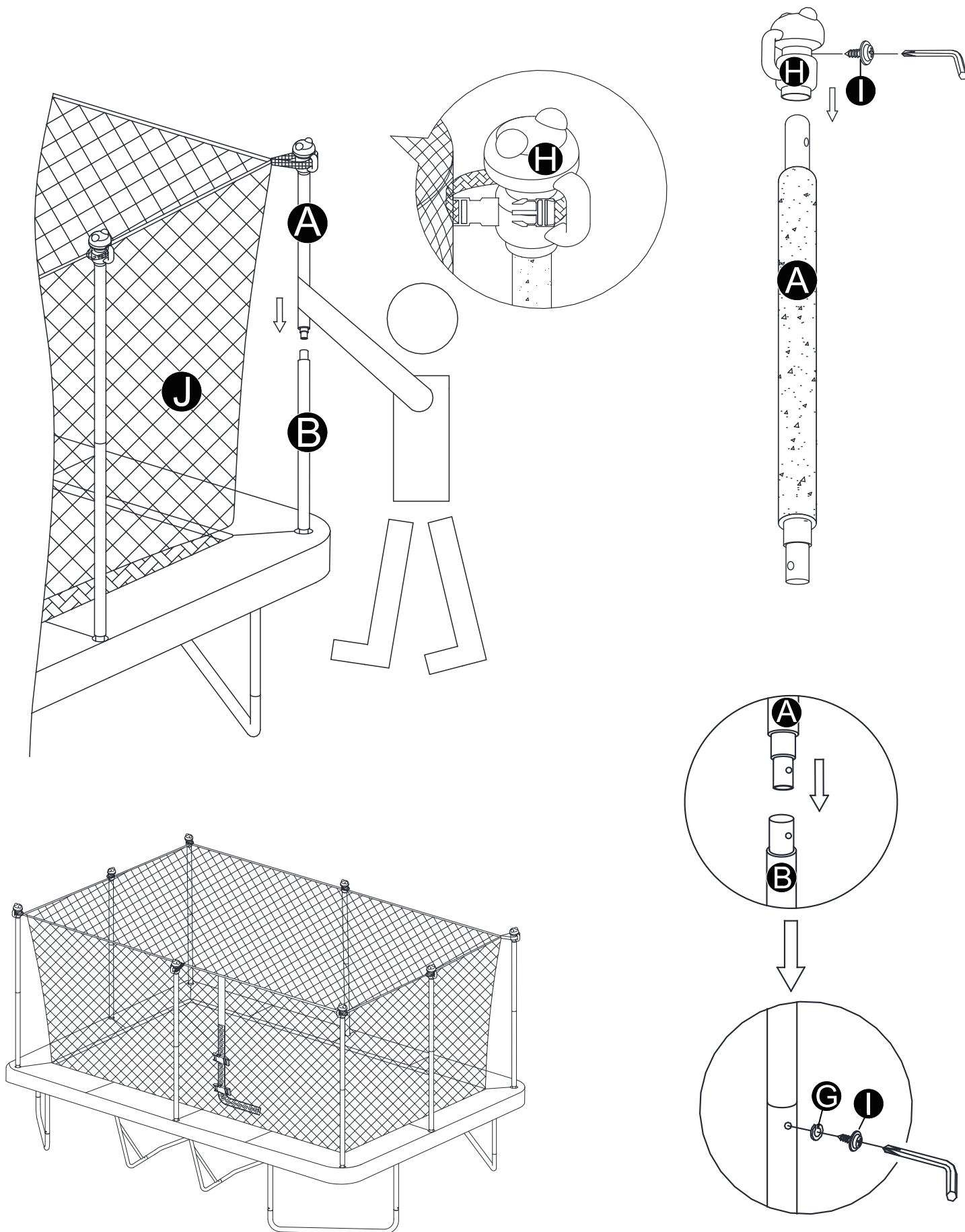

Assembly Instruction

STEP 11

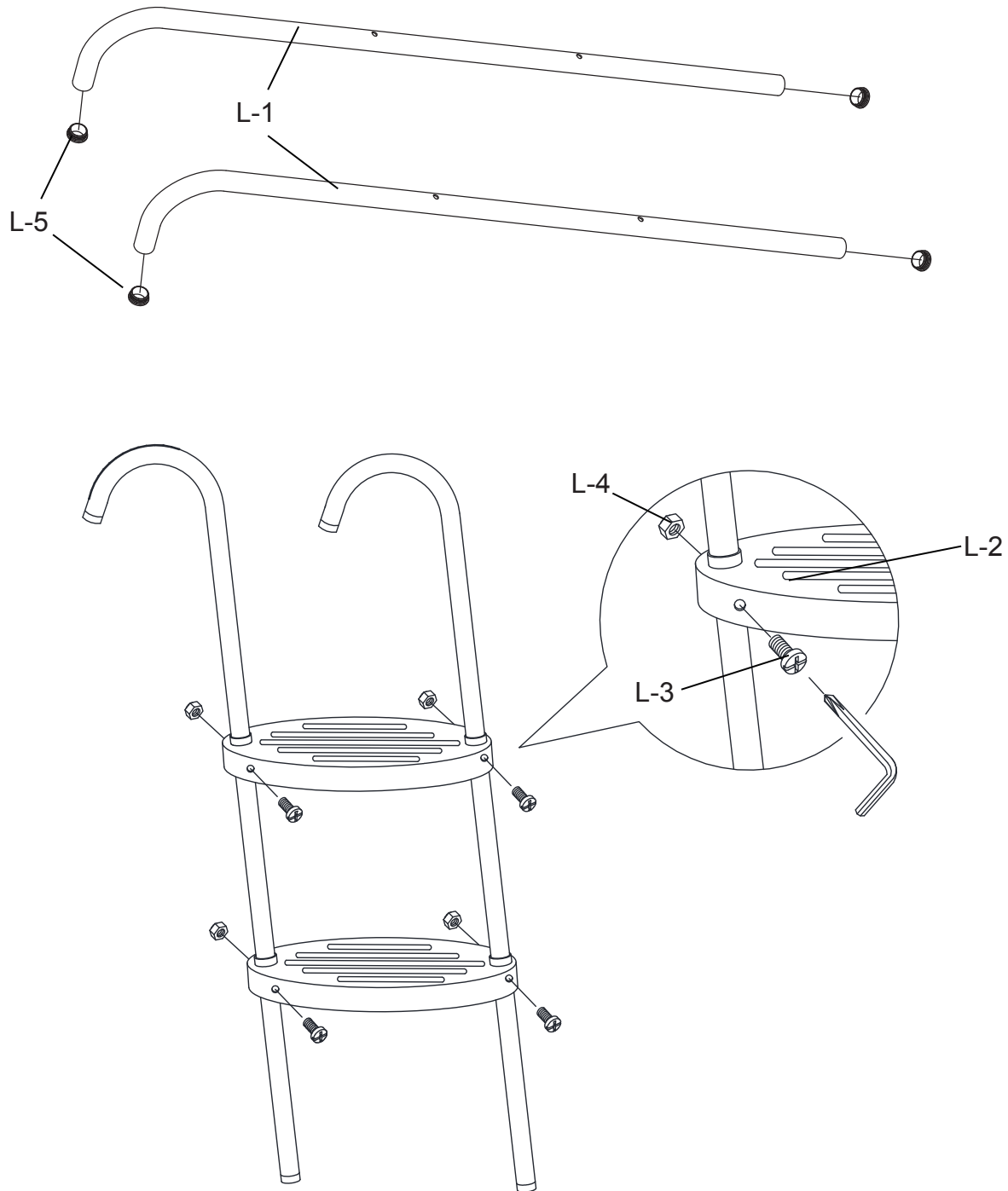

Assembly Instruction

STEP 12

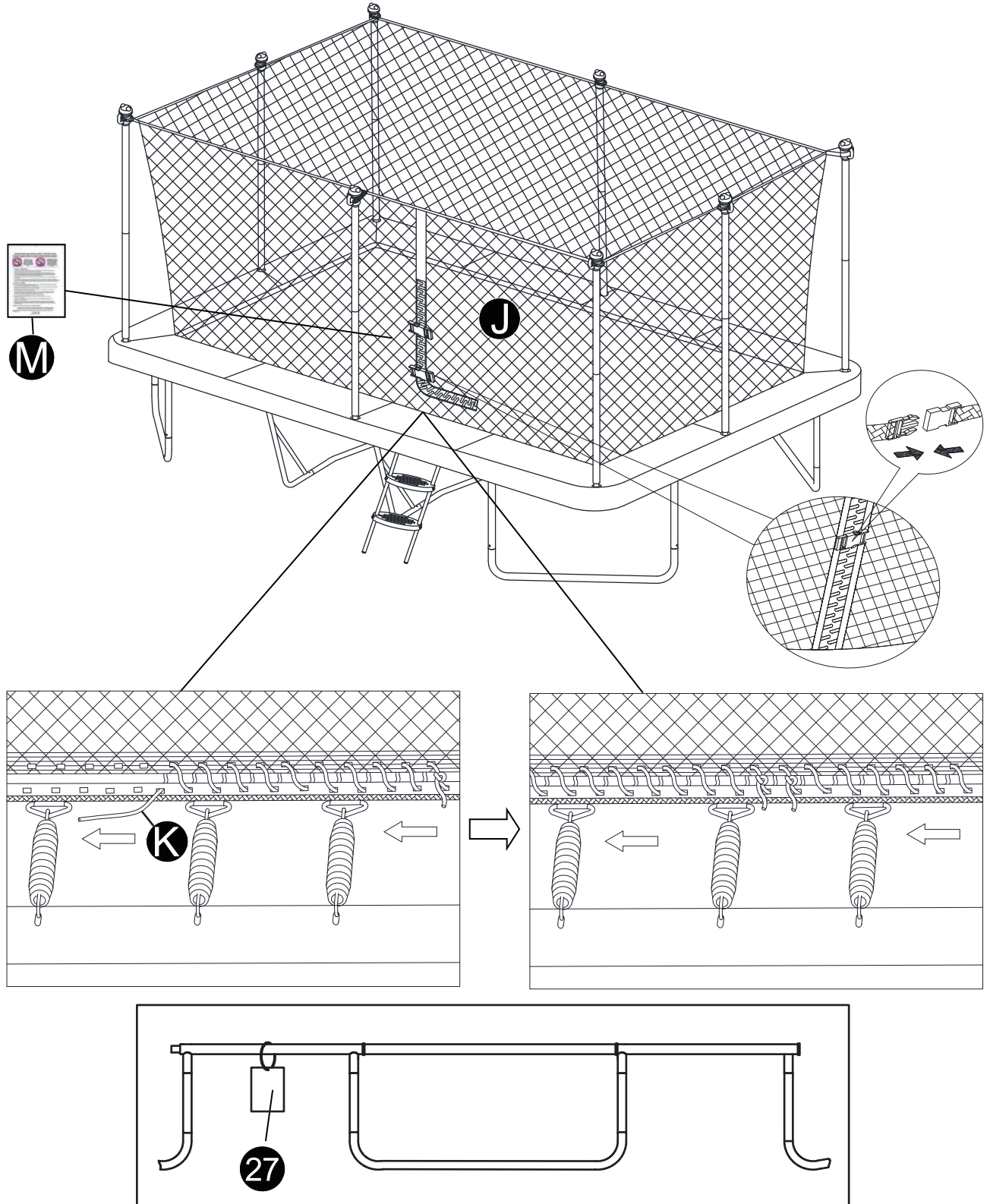

Disassembly of the Trampoline

To disassemble the trampoline, follow assembly in reverse order.

MOVING THE TRAMPOLINE

When moving, lift the trampoline slightly off the ground and keep it horizontal to the ground. For any type of other movement, you should disassemble the trampoline.