

INSTRUCTION MANUAL

MANUEL D'INSTRUCTIONS

MANUAL DE INSTRUCCIONES

Single Handle Lavatory Faucet
Robinet de lavabo à une poignée
Llave de una sola manija para lavabo

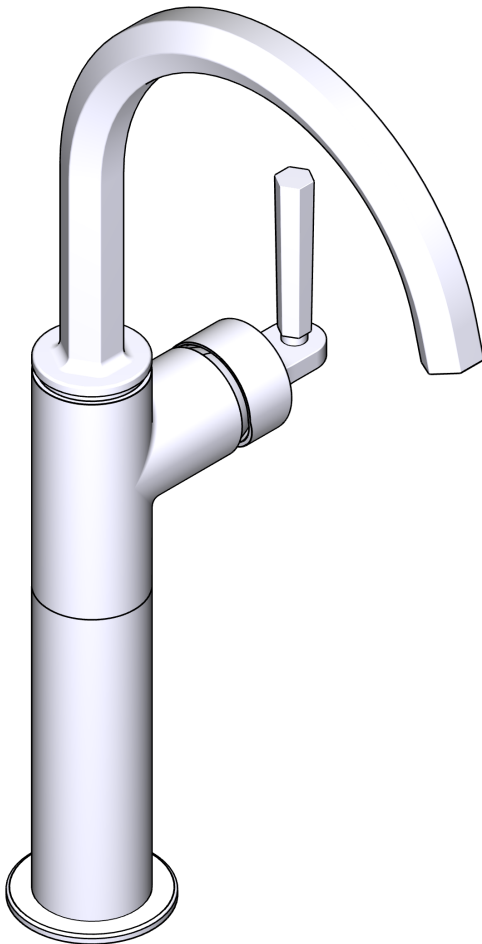

HELPFUL TOOLS

For safety and ease of installation, the use of these helpful tools is recommended.

OUTILS UTILES

Pour des raisons de sécurité et de facilité d'installation, l'utilisation de ces outils utiles est recommandée.

HERRAMIENTAS ÚTILES

Por seguridad y facilidad de instalación, se recomienda el uso de estas útiles herramientas.

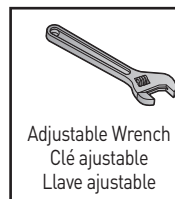

For warranty or additional information, contact:

US Customers

U.S.A.
houseofrohl.com/support
1-800-777-9762

QUEBEC / MARITIMES / WESTERN CANADA
 QUÉBEC / MARITIMES / OUEST CANADIEN
 QUEBEC / MARITIMOS / CANADA OCCIDENTAL
 houseofrohl.ca/support
 1-866-473-8442

Canadian Customers

ONTARIO
houseofrohl.ca/support
1-800-287-5354

ROHL

Parts List

- A. Faucet Body
- B. Escutcheon
- C. Gasket
- D. *Mounting Spacer
- E. Mounting Gasket
- F. Mounting Washer
- G. Mounting Nut

*Optional Mounting, used for deck thickness less than 1.7"

Liste des pièces

- A. Corps du robinet
- B. Rosace
- C. Joint d'étanchéité
- D. *Entretoise de montage
- E. Joint de montage
- F. Rondelle de montage
- G. Écrou de montage

* Montage optionnel, doit être utilisée avec une plaque de comptoir d'une épaisseur inférieure à 1,7 po

Lista de piezas

- A. Cuerpo de la llave
- B. Chapetón
- C. Empaque
- D. *Espaciador de montaje
- E. Junta de montaje
- F. Roldana de montaje
- G. Tuerca de montaje

* Montaje opcional, utilizado para un mostrador con un espesor inferior a 1.7"

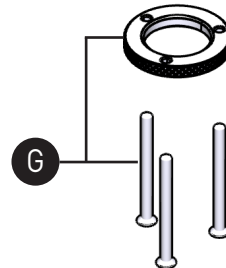
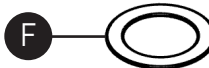
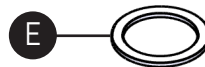
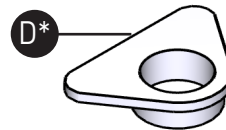
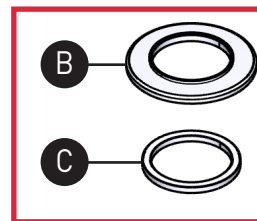
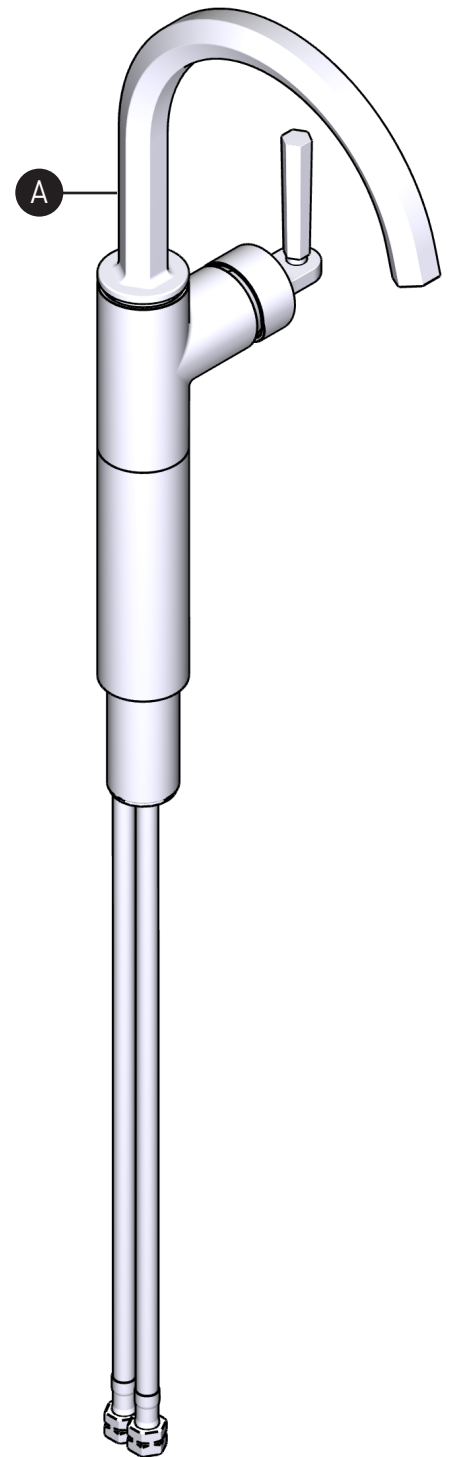

⚠ CAUTION — TIPS FOR REMOVAL OF OLD FAUCET:
Always turn water supply OFF before removing existing faucet or disassembling the valve. Open faucet handle to relieve water pressure and ensure that complete water shut-off has been accomplished.

ATTENTION — CONSEILS POUR LE RETRAIT DE L'ANCIEN ROBINET:
Toujours couper l'alimentation en eau avant de retirer ou de démonter le robinet. Ouvrir le robinet pour libérer la pression d'eau et pour s'assurer que l'alimentation en eau a bien été coupée.

PRECAUCIÓN — CONSEJOS PARA CAMBIAR LA LLAVE MEZCLADORA:
Siempre CIERRE la toma de agua antes de quitar la llave existente o desmontar la válvula. Abra la llave para liberar la presión, y asegúrese de que esté bien cerrada el agua.

Icon Legend/ Légende des icônes/ Leyenda de Iconos/



Warning
Avertissement
Advertencia



Above sink
Au-dessus du
lavabo
Encima del lavabo



Below sink
En dessous du lavabo
Debajo del fregadero

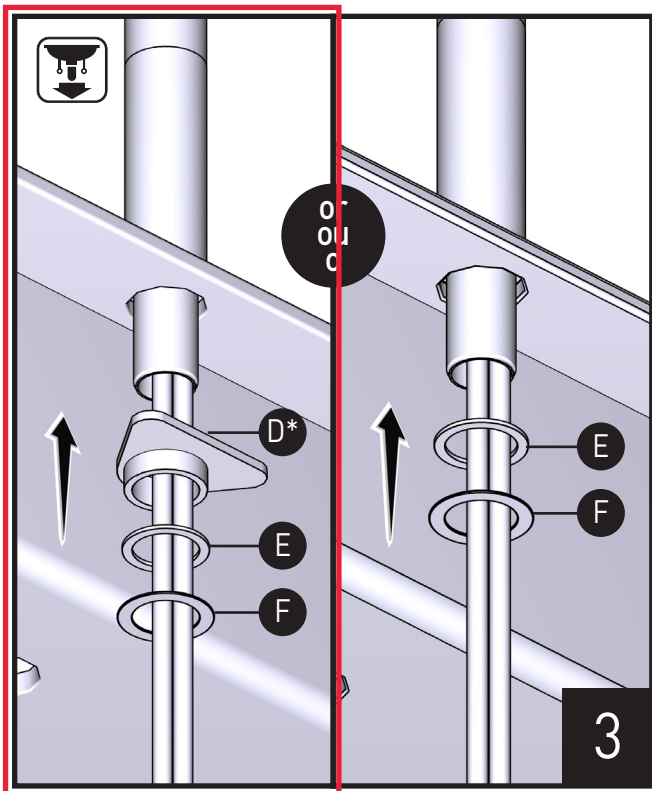
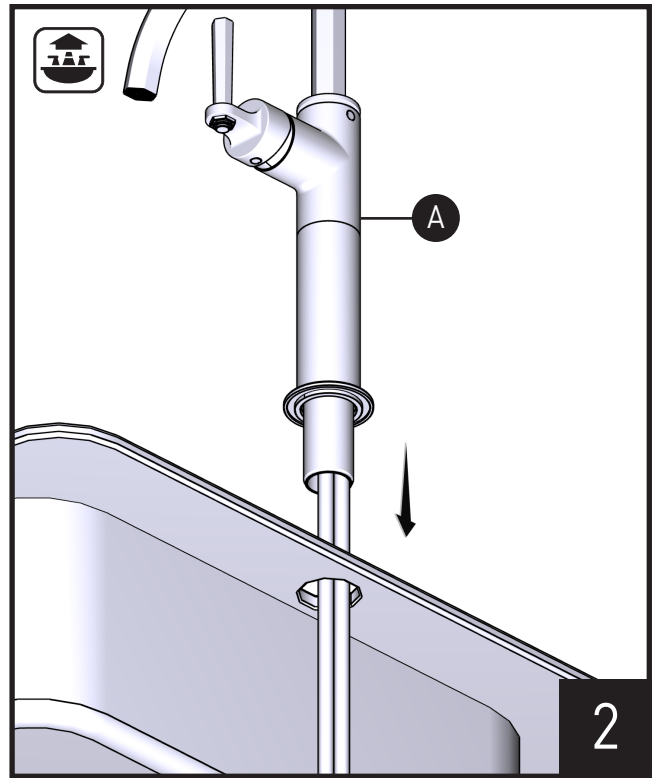
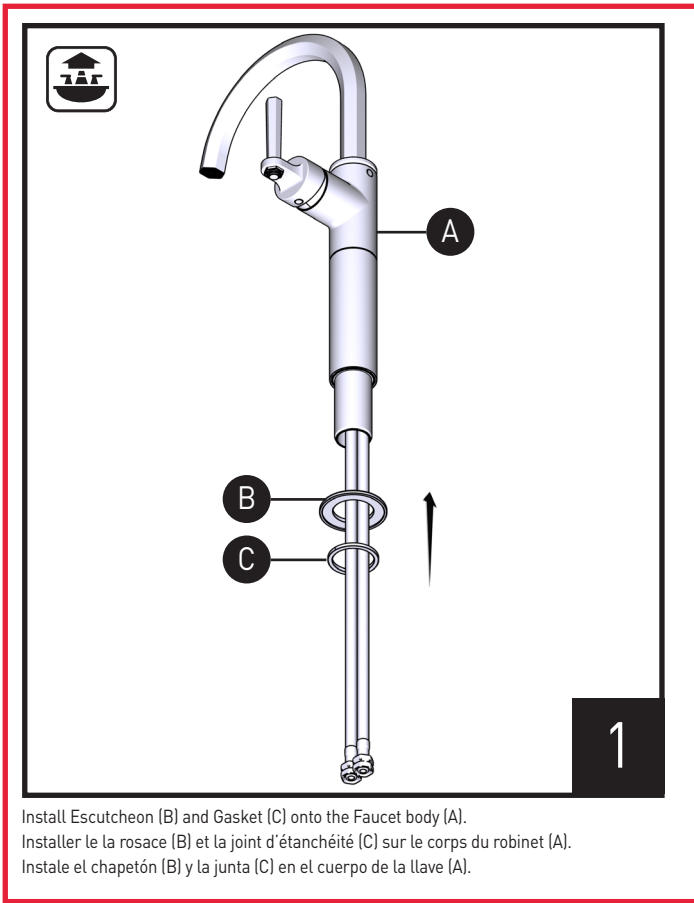

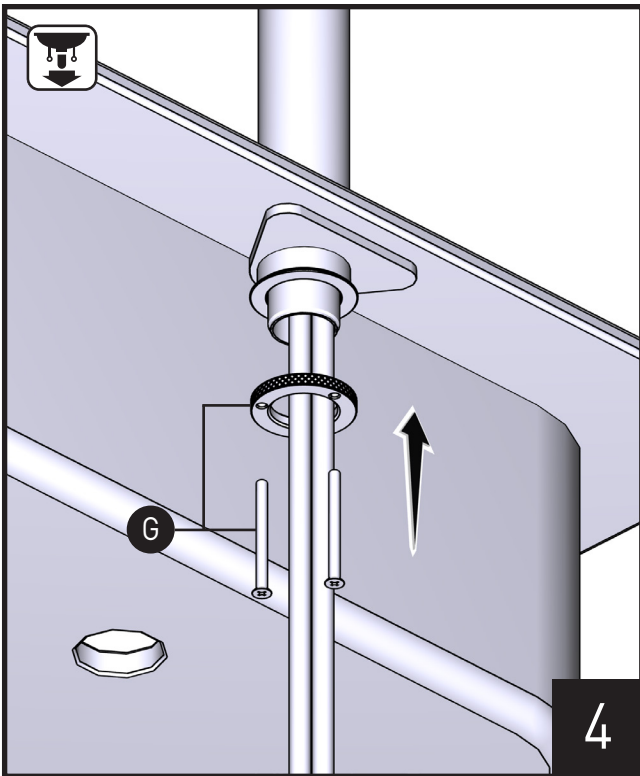

Install Mounting Nut [G] onto Mounting Shank.
 Installer l'écrou de montage [G] sur la tige de montage.
 Instale la tuerca de montaje [G] en la varilla de montaje.

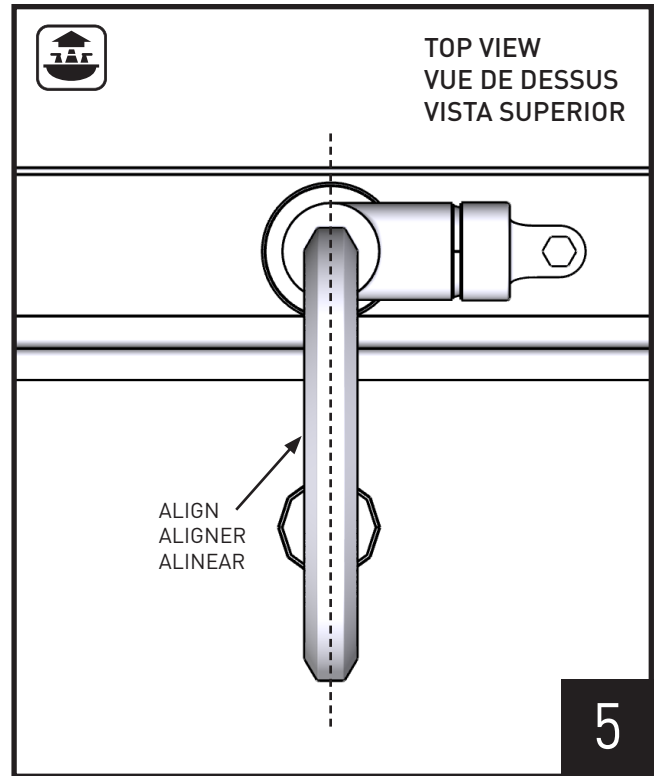

Check overall faucet alignment with sink drain hole from the top view.
 Vérifier, vu du dessus, l'alignement général du robinet sur l'orifice du drain du lavabo.
 Verifique la alineación general de la llave con el orificio de drenaje del lavabo desde la vista superior.

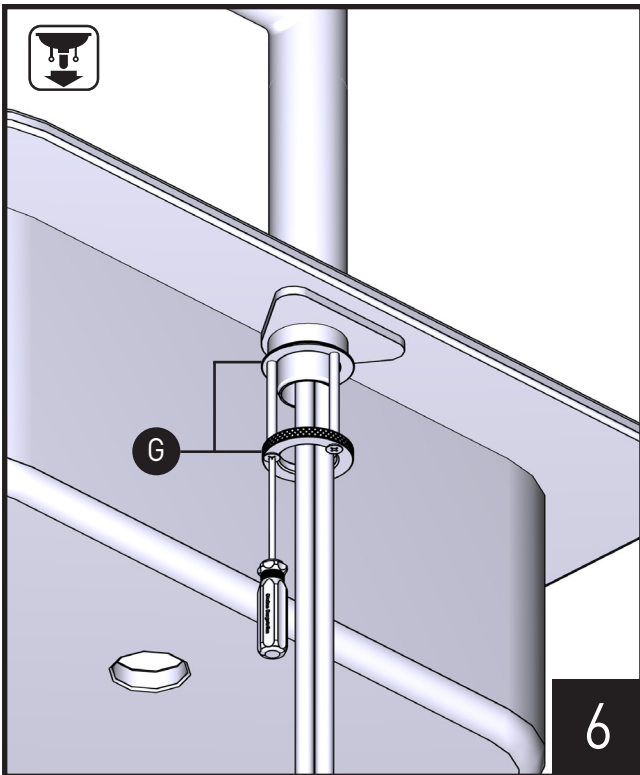

Tighten Mounting Nut [G] with screwdriver, once faucet alignment is confirmed.

Une fois confirmé le bon alignement du robinet, serrer l'écrou de montage [G] avec le tournevis phillips.

Apriete la tuerca de montaje [G] con la tournevis phillips, una vez que se confirme la alineación de la llave.

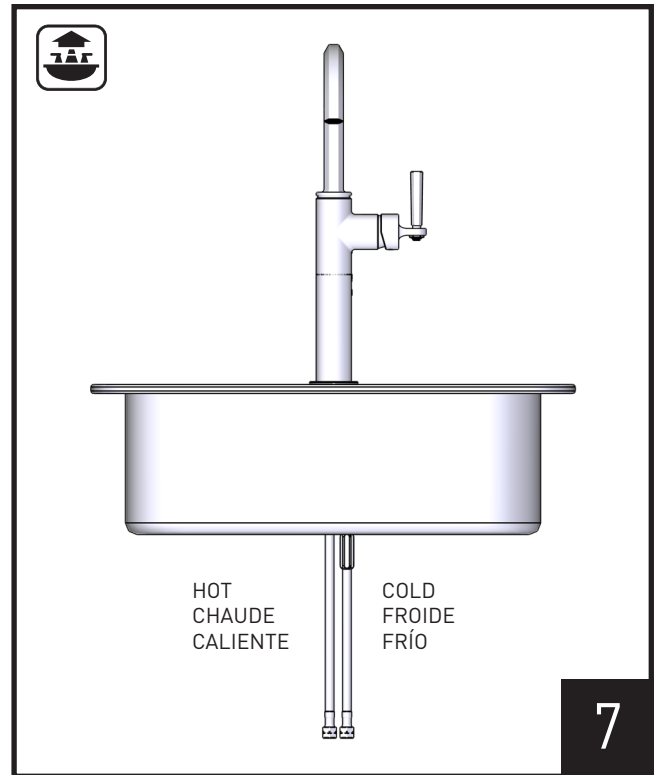

Check front view overall installation.

Vérifier l'installation du robinet, vue de face.

Compruebe la instalación general de la vista frontal.

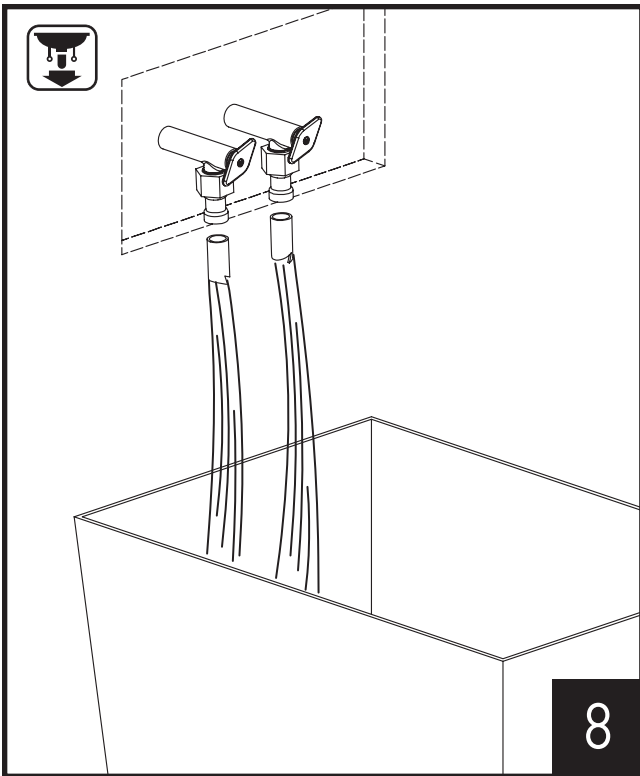

Run hot and cold water for 5 seconds.

Faire couler l'eau chaude et l'eau froide pendant 5 secondes.

Deje correr agua fría y caliente durante 5 segundos.

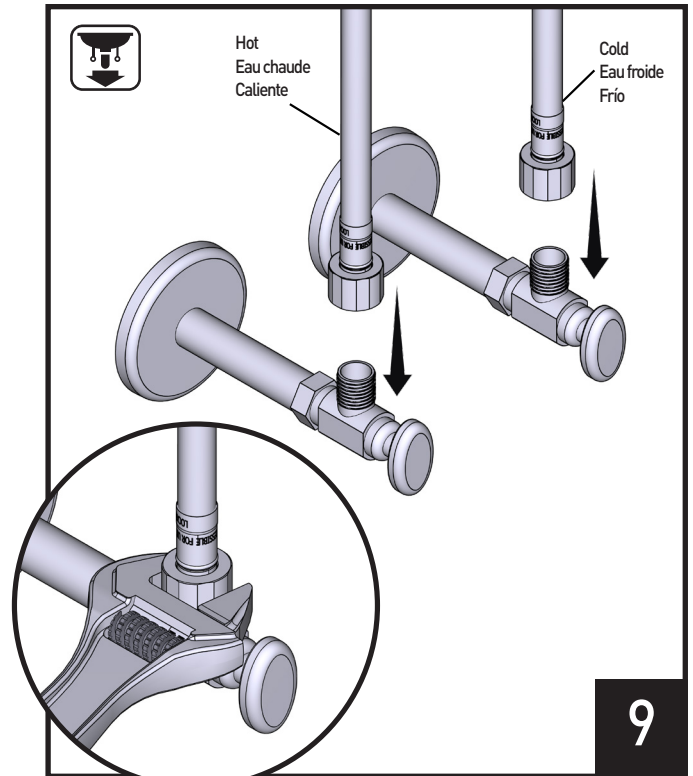

Attach flexible lines to shutoff valves. Tighten by hand, then 1/4 turn more with adjustable wrench.

Raccorder les conduites flexibles aux robinets d'arrêt. Les serrer à la main, puis faire 1/4 de tour supplémentaire avec une clé ajustable.

Conecte las líneas flexibles a las válvulas de cierre. Apriete a mano, después 1/4 de vuelta más con una llave inglesa.

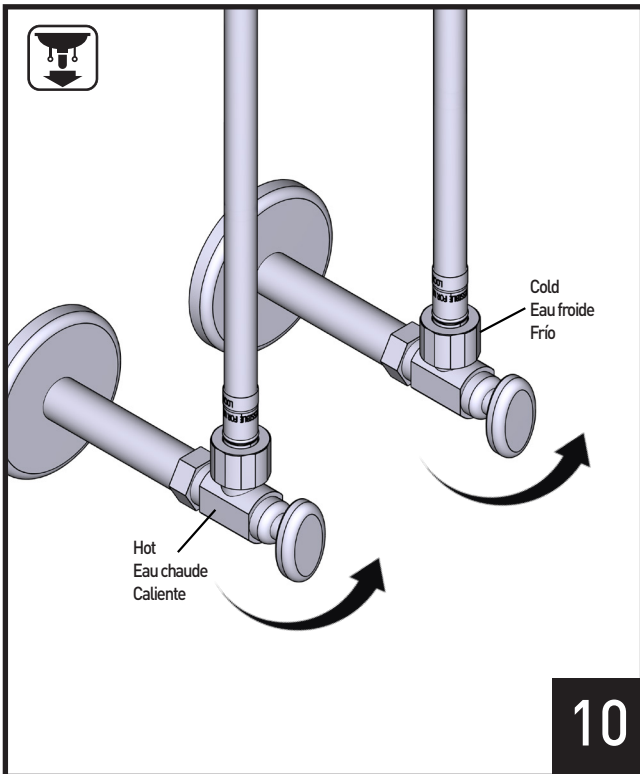

Turn on water and check for leaks.

Ouvrir l'eau et vérifier qu'il n'y a aucune fuite.

Abra la llave del agua y verifique que no haya fugas.

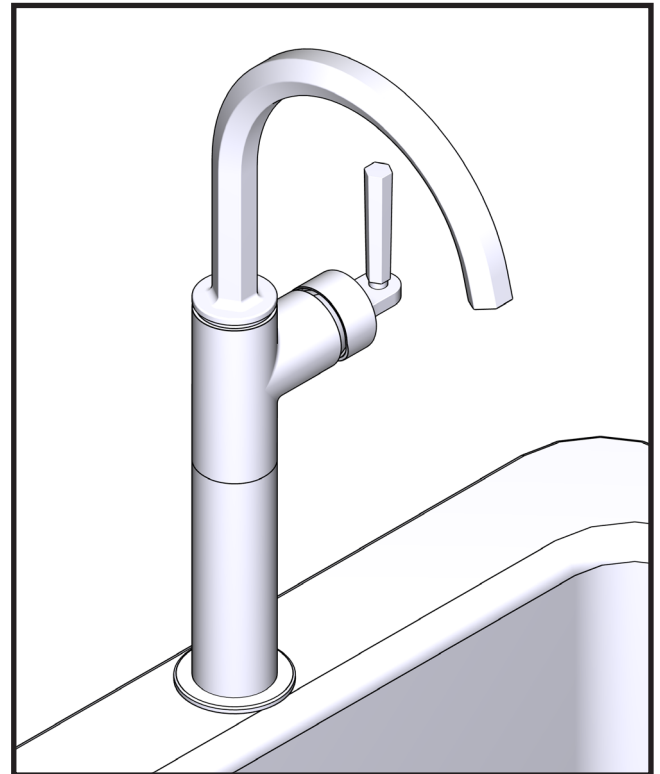

Installation is complete.

L'installation est terminée.

La instalación está completa.

Irregular Flow / Débit irrégulier / Flujo Irregular

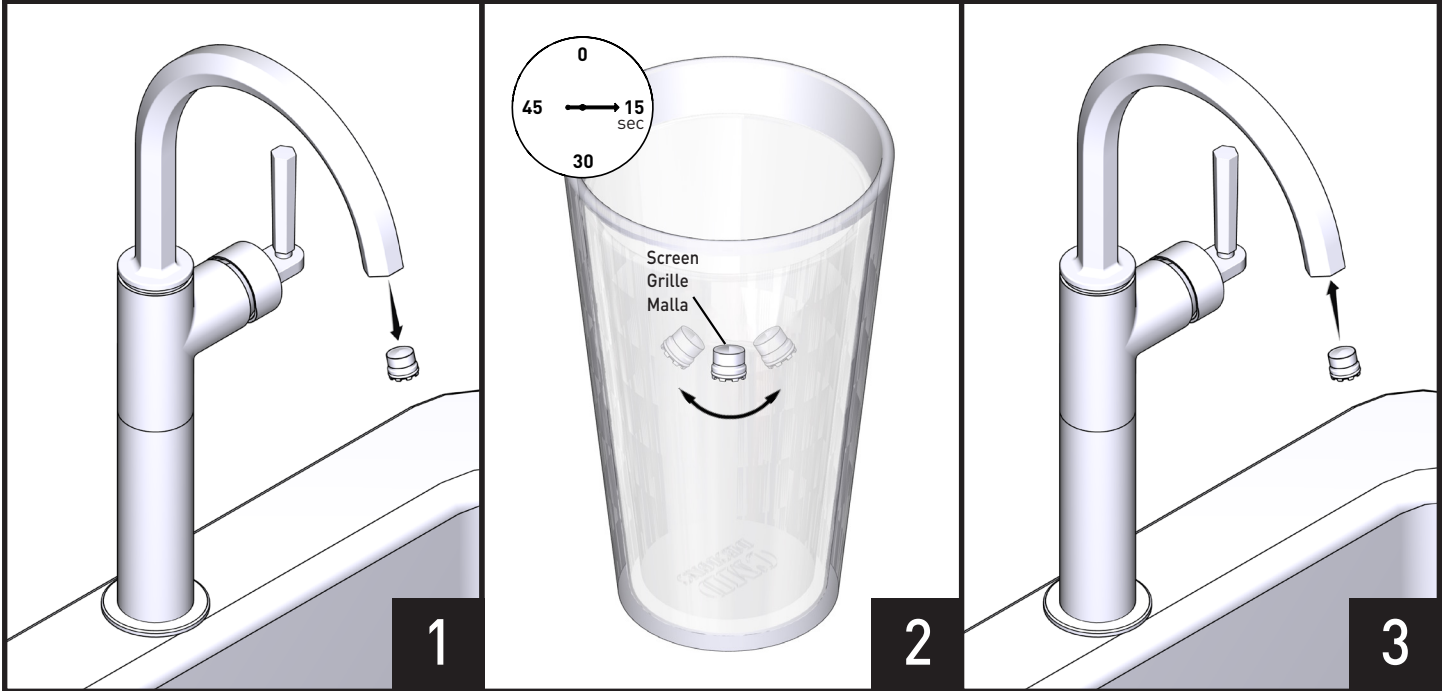

Remove screen from faucet and rinse debris from screen for 15 seconds. Then reinstall the screen into faucet.

Retirer le filtre du robinet, puis le rincer pendant 15 secondes pour en retirer tous les débris. Réinstaller ensuite le filtre dans le robinet.

Retire la malla de la llave y enjuague los residuos durante 15 segundos. Luego reinstala la malla en la llave.

For warranty or additional information, contact:

US Customers

U.S.A.
houseofrohl.com/support
1-800-777-9762

QUEBEC / MARITIMES / WESTERN CANADA
QUÉBEC / MARITIMES / OUEST CANADIEN
QUEBEC / MARITIMOS / CANADA OCCIDENTAL
houseofrohl.ca/support
1-866-473-8442

Canadian Customers

ONTARIO
houseofrohl.ca/support
1-800-287-5354

Riobel

PERRIN & ROWE
LONDON



victoria ⊕ albert®

ROHL