

SIDES	BOTTOM
4 1/2"-3/4"MOONKNOCKOUTS	2 1/2" KNOCKOUTS
8 1/2" KNOCKOUTS	2 3/4" KNOCKOUTS
	1 Ground Hump
2 PCS 8-32x1/2 Screws Installed	
1 PCS 10-32x3/8 Screws Installed	
Material:Steel-0.0625"-G60 Galvanized	

4 1/2"KNOCKOUTS $\phi=22.50$ [$\phi=0.886$]

12 PLACES SPOT WELDING

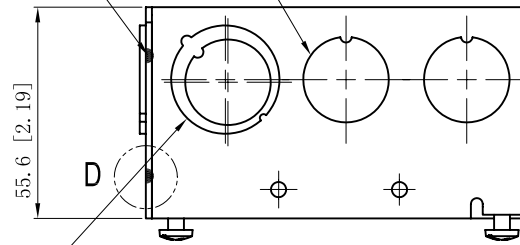

2 1/2"-3/4"MOON KNOCKOUTS $\phi=22.50$ [$\phi=0.886$]
 $\phi=28.50$ [$\phi=1.122$]

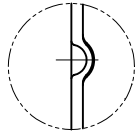
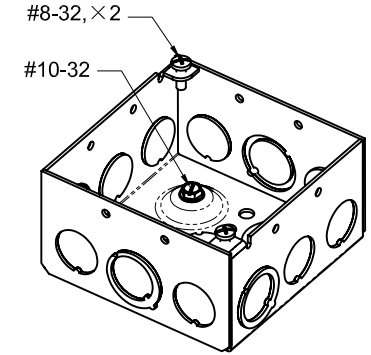

WELDING STYLE DETAIL VIEW D

2 3/4"KNOCKOUTS $\phi=28.50$ [$\phi=1.122$]

#10-32 UNF

2 1/2"-3/4"MOON KNOCKOUTS $\phi=22.50$ [$\phi=0.886$]
 $\phi=28.50$ [$\phi=1.122$]

4 1/2"KNOCKOUTS $\phi=22.50$ [$\phi=0.886$]

2 1/2"KNOCKOUTS $\phi=22.50$ [$\phi=0.886$]

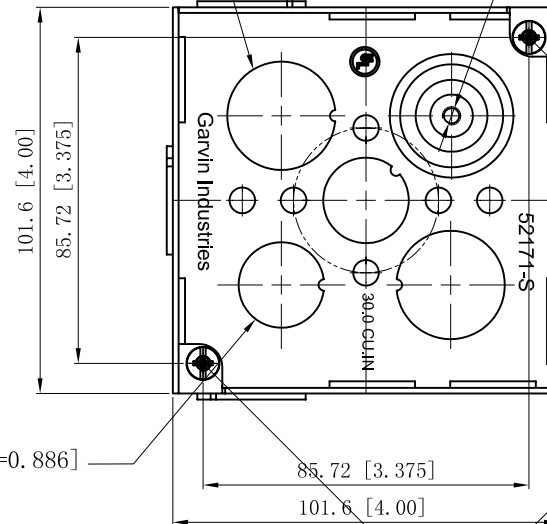

This data sheet is for reference only.GARVIN INDUSTRIES reserves the right to make changes to the design without prior notice.

DESCRIPTION
TRADE REFERENCE TERMS

STANDARD PACKING
25 PCS

TITLE			REV
4" SQUARE BOXES 2-1/8" DEEP			
SIZE	DWG NO.		
A4	52171-RED		C
DATA SHEET			