

Cuisinart® PrecisionSlice™ Upright Mandoline

FEATURES

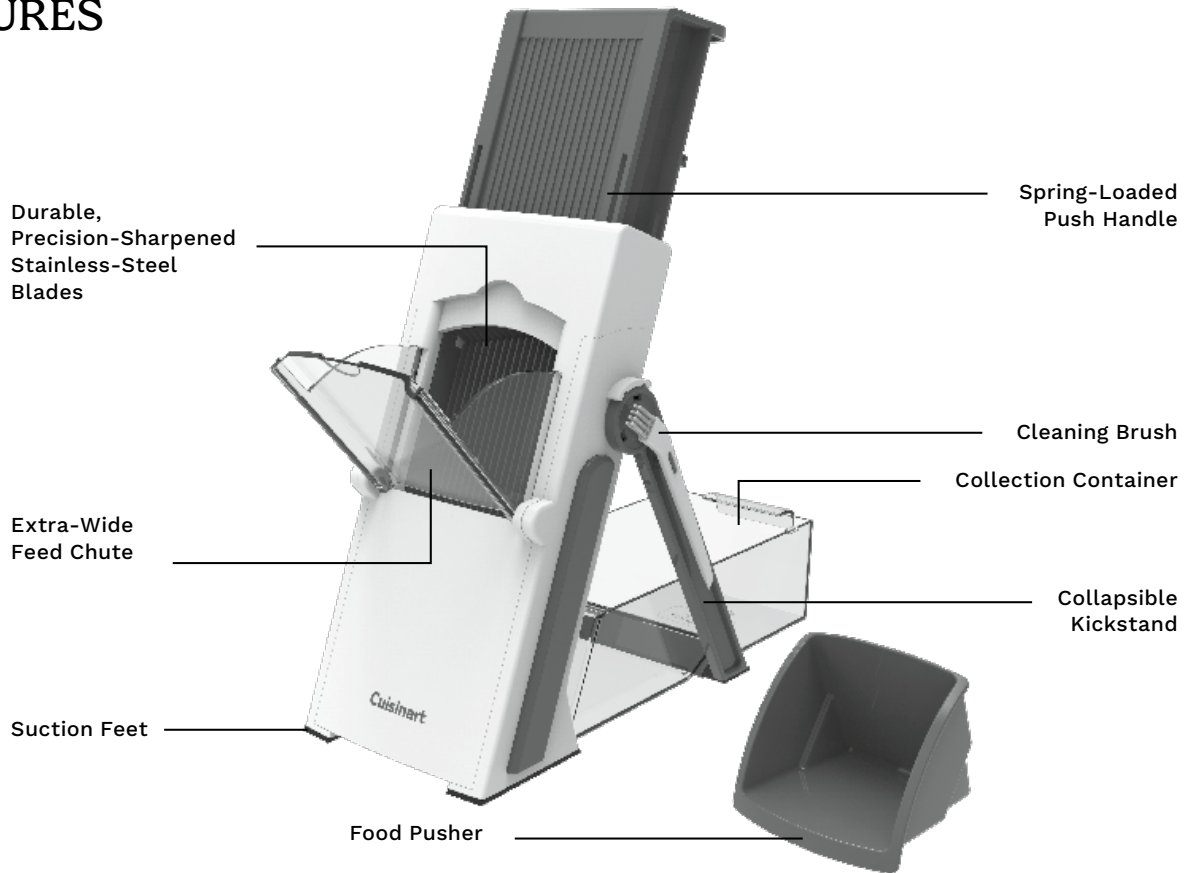

SAVE THESE INSTRUCTIONS CAUTION

SPECIAL INSTRUCTIONS

- The Cuisinart® mandoline's stainless steel blades are extremely sharp. **Please handle with care.** Keep fingers and hands away from blades when using, cleaning, assembling, or reassembling the unit.
- **ALWAYS** use the food pusher to guide food properly into the cutting blade and to prevent injuries.
- **Never use your hands instead of the food pusher** to guide food.
- Prongs and pins are very sharp; always use caution when placing food onto or removing it from the food pusher.
- Always set the thickness dial to zero to lower the blades for safe storage.
- **Keep this product and its components away from children.**

PARTS

This package contains a Cuisinart® PrecisionSlice™ Upright Mandoline and the following components:

1. Mandoline body
2. Food pusher
3. Collection container
4. Cleaning brush

CONTENTS

Features	1
Special Instructions	1
Parts	1
Operating Instructions	2
Cleaning and Storage	2-3
Suggested Usage and Tips	3-4
Recipe	5
Warranty	10

Read instructions before using.

OPERATING INSTRUCTIONS

1. Before first use, wash the body of the mandoline and all components with hot, soapy water. Refer to instructions 2–4 to separate parts for cleaning.
2. Slide the collection container to separate it from mandoline body. Remove the food pusher.
3. Open the kickstand until it clicks into place and is fully extended. Place the mandoline upright. Place the collection container over the kickstand (with the handle facing out).
4. Hold the spring-loaded handle, push down firmly, and use your free hand and the finger notch to open the feed chute (see Image A). Slowly release the handle.
5. Refer to the Cutting Guide below to select cuts and thicknesses.
6. Trim your food, if necessary, to fit in the feed chute.
7. Place your food in the chute. Use the food pusher with one hand to guide the food (teeth facing the cutting runway). With your other hand, push the handle down to cut. Release the handle to return to the starting position.
8. Return the thickness dial to zero before washing and storing the mandoline.



Image A

CUTTING GUIDE

- Use the dial to select your cut thickness (see Image B)
- To slice: Both sliders to the OFF position
- To thin julienne: Both sliders to the ON position
- To thick julienne: One slider ON, one slider OFF
- To dice: Adjust sliders into SLICE mode. Place julienne strips upright into the food chute. Use food pusher to hold and guide julienne strips as you dice.
 - For small dice use thin julienne strips.
 - For large dice use thick julienne strips.

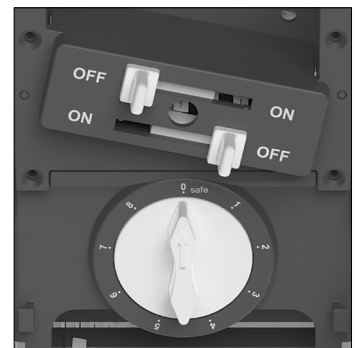

Image B

CLEANING AND STORAGE

EASY TO CLEAN

1. Remove the food pusher and collection container from the mandoline.

- Carefully remove any remaining food with the cleaning brush.
- Wash the food pusher, mandoline, and collection container with warm, soapy water and let dry.
- Do not submerge mandoline and hand-wash only. Collection container is top rack dishwasher safe.

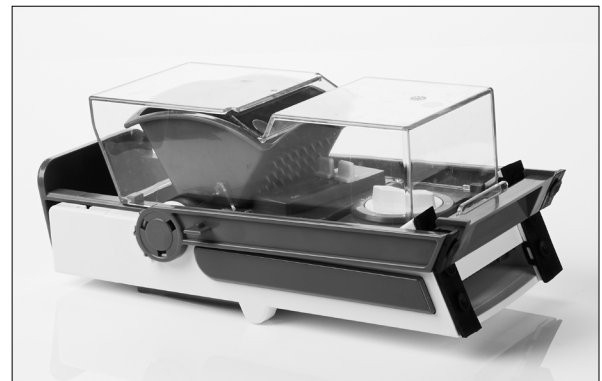

SAFE AND EASY TO STORE

- Be sure the mandoline and all parts are washed and thoroughly dry.
- Make sure the thickness adjuster dial is set to zero. Set both sliders to the OFF position.
- Push and hold down the handle. With your other hand, close the chute.
- Fold the kickstand legs flat.
- Place the food pusher on the back of the mandoline with the notch pointing down. Slide and lock to attach the collection container (see image C).

SUGGESTED USAGE AND TIPS

FOODS	STRAIGHTEDGE BLADE	JULIENNE BLADE	RECIPE IDEAS
Apples	✓	✓	Use the straightedge blade with the thickness dial set between 2 and 3 for apple chips, or 4 for perfect slices for an apple pie.
Beets	✓	✓	Use the straightedge blade with the thickness dial set between 2 and 3 for beautiful beet chips.
Bok Choy	✓		
Broccoli Stalks	✓	✓	Don't toss those broccoli stalks. After peeling the tougher outer parts, use the julienne blade to cut the stalks to use in stir fries or raw in salads.
Brussels Sprouts	✓		Use the straightedge blade on a thin setting to prep the sprouts to use in a salad. We love replacing romaine with sliced Brussels sprouts in a twist on a Caesar salad.
Butternut Squash	✓		Use the straightedge blade with the thickness dial set between 2 and 3 for perfect slices for roasting or air frying.
Cabbage	✓	✓	Using the straightedge blade is the best way to prep cabbage for any type of slaw.
Carrots	✓	✓	Use thin julienne setting up to 4 and thick julienne setting up to 7. Use the straightedge blade to slice carrots into coins of any size for roasting or eating raw for dipping.
Cauliflower	✓		Thickly slice cauliflower for roasting.
Cucumbers	✓	✓	Slice, between 2 and 4 on the thickness dial, to toss in a refreshing cucumber salad, or to layer in your favorite sandwich.
Daikon	✓	✓	This radish gives zing to salads and crudite platters. Use any setting to slice and cut as desired, be it thick julienne cuts at setting 4, or thin slices at setting 2.
Eggplant	✓	✓	Use the straightedge blade with the thickness dial set to 4 to achieve perfect slices for eggplant Parmesan.
Endive	✓		Using the straightedge blade on settings 2 to 4 is the best way to prep endive. Toss it with mixed greens and a light vinaigrette for a refreshing salad.
Fennel	✓		Sliced fennel adds great flavor, when it is roasted with other vegetables.
Ginger	✓	✓	Thinly slice peeled ginger, on setting 1 or 2, to prep for pickling. Or on setting 2 for a thin julienne cut to add to a stir fry.
Iceberg Lettuce	✓	✓	For a hearty salad, slice lettuce on a medium setting 4 to 5, and then toss with your favorite salad ingredients.
Lemons	✓		Make the perfect lemon slices with the straightedge blade on setting 1 to add to a pitcher of lemonade, iced tea, or water.
Onions	✓		Use the straightedge blade with the thickness dial set to 4 to make perfect onion rings.
Oranges	✓		
Parsnips	✓	✓	Slice with the straightedge blade on settings 4 to 6 to prep for soups, or use the julienne blade for roasting.
Pears	✓	✓	Slice for pies, tarts, and all your other favorite baked desserts.
Peppers	✓		Use the straightedge blade with the thickness dial set to 4 to slice a variety of bell peppers to grill on the barbecue.
Potatoes	✓	✓	Slice thinly for potato chips, thickly for a quick version of smashed potatoes, or use the thick julienne blade at setting 4 to make the perfect french fries.
Radicchio	✓	✓	Slice and mix into coleslaw for added crunch and color.
Radishes	✓	✓	Use the thin julienne on setting 2 to add into a salad, or use the straightedge blade to slice to desired thickness for salads or sandwiches.
Rutabaga	✓	✓	Using the thick julienne setting on 4 to 6 thickness level, you can make a tasty alternative french fries when tossed with oil and air fried or roasted.
Summer Squash	✓	✓	Summer squash looks beautiful when julienned with the thickness dial set between 1 and 2. Toss with pasta or grains.
Tomatoes	✓		Use the straightedge blade with the thickness dial set at 4 or higher. Results vary based on firmness and type of tomato.
Turnips	✓	✓	Another favorite for roasting, make into chips, french fry cuts, or thinner julienne for crispy bites.
Zucchini	✓	✓	There are so many options with zucchini, be it zucchini fries, on setting 4 with a thick julienne, or a medium slice with the straightedge blade for a quick sauté.

OTHER TIPS

- Always use the food pusher when slicing.
- Using a mandoline takes some practice. You may not get perfect results right away, but after a few tries, you will be slicing like a pro.
- Softer foods may require less pressure when cutting, while harder foods may call for more pressure.
- Prepare a quick salad or stir-fry with a mix of julienned and sliced vegetables.
- For optimal results when slicing tomatoes, use setting 4 or higher. Results vary based on firmness and type of tomato. Works best on plum or Roma tomatoes.
- Prepare fruit or vegetable platters in a flash.
- For harder foods, like carrots, use thin julienne setting up to 4 and thick julienne setting up to 7.
- Make sure to push the handle all the way down and come all the way up, swiftly, for optimal results.
- It is easiest to cut foods that are flat on the bottom. Trim rounded edges so they are flush with the cutting surface.

RECIPES

Potatoes au Gratin

Thinly sliced potatoes are the star of this luxurious side dish.

Makes 12 servings

- 2 garlic cloves, minced**
- 1 medium shallot, minced**
- 2 cups heavy cream**
- 2 teaspoons fresh thyme leaves, plus more for garnish**
- 1 teaspoon kosher salt, plus more as needed**
- ¼ teaspoon freshly ground black pepper, plus more as needed**
- 4 pounds russet potatoes, scrubbed and peeled**
- 3 ounces Gruyère, finely grated**
- 1 ounce Parmesan, finely grated**

1. Preheat the oven to 350°F.
2. Butter a 9x13-inch baking dish with 1 tablespoon of the butter.
3. In a small saucepan, melt the remaining 1 tablespoon butter. Add the garlic and shallot, and sauté until aromatic. Add the cream, thyme, 1 teaspoon salt, and ¼ teaspoon pepper. Bring to a simmer and cook for 5 minutes while prepping the potatoes.
4. Position the sliders to the slice position and set the turn dial between settings 1 and 2. Slice the potatoes.
5. Shingle a single layer of sliced potatoes in the prepared baking dish. Season with salt and pepper. Ladle one-third of the heavy cream mixture over the potatoes and then sprinkle one-third of the Gruyère over the potatoes. Repeat this layering one more time. Add one final layer of potatoes, season with salt and pepper, and top with the remaining heavy cream mixture.
6. Cover the baking dish with foil. Transfer to the oven and bake for 60 to 70 minutes, until the potatoes are cooked through.
7. Heat the broiler. Remove the foil and top with the Parmesan and remaining Gruyère. Broil until the cheeses turn golden brown. Let stand for 15 minutes, then garnish with additional thyme before serving.

Asian Slaw with Ginger-Sesame Dressing

The Cuisinart® PrecisionSlice™ Upright Mandoline makes homemade coleslaw possible.

Here is a delicious Asian-flavor-inspired version. This colorful side dish goes beautifully with grilled fish or chicken.

Makes 8 to 10 servings

Dressing:

- 1 garlic clove, peeled
- 1 inch piece ginger, peeled
- 1 tablespoon natural-style peanut butter, chunky or creamy
- 1 tablespoon rice vinegar
- 2 tablespoons soy sauce (reduced sodium works well)
- 1 tablespoon honey
- 2 tablespoons sesame oil (we recommend hot sesame oil, but it may be a bit too spicy for some. If so, use half regular sesame oil and half spicy)

Salad:

- 6 small to medium red radishes, trimmed
- 1 broccoli stalk (florets trimmed and reserved for another use)
- 2 medium carrots, peeled and halved to fit the safety guard
- 2 medium stalks bok choy (greens trimmed and reserved for another use)
- ½ small radicchio
- ¼ small to medium green cabbage
- ½ small to medium red cabbage
- ¼ cup chopped cilantro

1. Put the garlic and ginger in a Cuisinart® Food Processor fitted with the metal blade. Process until finely chopped. Add the peanut butter, rice vinegar, soy sauce and honey. Process until fully combined. With the unit running, add the oil through the drizzle hole in the feed tube and process until emulsified. Reserve.
2. Position the sliders to the thin julienne setting and set the turn dial between setting 1 and 2mm. Use the food holder to julienne the radishes, broccoli, and carrots; reserve in a large mixing bowl.
3. Position the sliders to the slice position and set the turn dial to 2mm. Use the food holder to slice the bok choy and radicchio; add to the mixing bowl. Re-adjust the slice thickness on the indicator between setting 1 and 2 mm. Use the food holder to slice the green and red cabbage; add to the mixing bowl.
4. Add the chopped cilantro to the vegetables and toss – using tongs works best – to fully combine. Right before serving, add the reserved dressing and toss to fully coat. (NOTE: It is important not to add dressing until immediately before serving; otherwise the salad will not be as bright in color and the vegetables will not be as crisp.)

Nutritional information per serving (based on 10 servings):
Calories 81 (47% from fat) • carb. 9g • pro. 2g • fat 5g • sat. fat 1g
chol. 0mg • sod. 162mg • calc. 45mg • fiber 2g

Perfect French Fries

The Cuisinart® PrecisionSlice™ Upright Mandoline makes cutting perfect French fries a breeze!

Makes 2 to 3 servings

Vegetable or peanut oil for frying

1 pound russet potatoes

Kosher salt and freshly ground pepper to taste

1. Heat oil in a Cuisinart Compact Deep Fryer to 325°F.
2. Scrub potatoes well or peel if preferred.
3. Position the sliders to the thick julienne and set the turn dial to 8.
4. If needed, trim the potato to fit in the food chute and use the food pusher to julienne the potatoes. As you slice, put the French fries into a bowl of ice water to keep them from turning brown.
5. Once oil is ready, drain and dry the French fries completely and thoroughly in batches. (If they are wet at all, the oil will spatter and spit.) Fry the potatoes in small batches. Cook for about 3 minutes, remove and drain on a tray lined with a wire cooling rack, or on layers of paper towels.
6. Increase the oil temperature to 375°F. In small batches again, fry the potatoes for a second time, this time about 4 minutes, until golden and crispy. Drain on fresh layers of paper towels. Season with salt and pepper to taste when hot and serve immediately.

NOTE: French fries can be fried once in 375°F until golden brown. Frying them twice makes them extra crispy!

Nutritional information per serving (based on 10 servings):
Calories 332 (64% from fat) • carb. 27g • pro. 3g • fat 24g • sat. fat 4g
chol. 0mg • sod. 52mg • calc. 20mg • fiber 2g

Radish, Cucumber, and Feta Salad

This light and colorful salad is full of bright flavors and couldn't be easier to make.

Makes 5 cups

- 1** **tablespoon fresh lemon juice**
- 2** **tablespoons extra-virgin olive oil**
 - 1 to 2 pinches sea salt**
 - 1 to 2 pinches freshly ground black pepper**
- 1** **bunch small radishes, trimmed (about 8 radishes)**
- ½** **medium seedless cucumber, trimmed**
- 2** **ounces crumbled feta cheese**
 - ¼ to ½ cup mixed fresh herbs, roughly chopped (parsley, mint, basil, etc.)**

1. Put the lemon juice, olive oil, salt, and pepper in a small bowl and whisk until homogenous. Reserve.
2. Position the sliders to the slice position and set the turn dial between settings 2-3. Slice the radishes and then the cucumber and transfer to a serving bowl. Add about 1 tablespoon of the dressing to the vegetables and toss gently to coat.
3. Add crumbled feta to the bowl with the dressed vegetables, along with the chopped herbs. Toss gently to combine.
4. Taste and adjust seasoning as desired, adding more salt and pepper or more dressing. Serve immediately.

Nutritional information per serving (based on 10 servings):
Calories 52 (72% from fat) • carb. 2g • pro. 2g • fat 4g • sat. fat 2g
chol. 10mg • sod. 162mg • calc. 62g • fiber 0g

Parmesan Zucchini Fries

A quick and cheesy treat!

Makes 2 to 3 servings

2 medium zucchini, trimmed to fit food chute

1 large egg

½ teaspoon salt

½ cup grated Parmesan cheese

1 teaspoon Italian seasoning (optional)

Olive oil, for greasing the baking sheet or AirFryer basket

Marinara sauce, warmed for serving

1. Position the sliders to the thick julienne position, set the turn dial to 8 and cut the zucchini. Put cut zucchini in a colander set over a bowl and sprinkle with ½ teaspoon salt. Let sweat for 15 to 20 minutes. Rinse and completely dry.
2. Beat the egg in a shallow bowl. In a separate bowl, combine parmesan and Italian seasoning.
3. **Bake:** Preheat the oven to 425°F with a rack positioned in the lower third. Liberally grease a baking sheet with olive oil. Dip cut zucchini into the egg, dripping off any excess, and dredge in the seasoned Parmesan. Spread out in a single layer on the prepared baking sheet. Bake for 30 to 35 minutes, flipping halfway through, until golden brown and crisp.
Air-Fry: Place the Cuisinart® AirFryer Basket onto the Baking/Drip Pan and liberally spray with olive oil. Dip cut zucchini into the egg, dripping off any excess, and dredge in the seasoned Parmesan. Transfer to the greased AirFry basket in a single layer, AirFrying in two batches if needed. AirFry in the upper position at 400°F for 8 to 10 minutes, flipping halfway through, until golden brown.
4. Taste finished fries and adjust seasoning as desired. Fries will continue to crisp up as they cool down. Serve with warmed marinara sauce.

Nutritional information per serving (based on 10 servings):

Calories 113 (51% from fat) • carb. 4g • pro. 9g • fat 6g • sat. fat 2g
chol. 75mg • sod. 328mg • calc. 460mg • fiber 1g

LIFETIME WARRANTY (U.S. AND CANADA ONLY)

Subject to the exclusions and limitations contained herein, Conair LLC dba Cuisinart (“Cuisinart”) warrants that the Cuisinart Tools & Gadgets will be free from material defects in materials and workmanship under normal home use conditions throughout the original purchaser’s lifetime, beginning on the date this Product was purchased in its original, sealed packaging, unless otherwise specified in this Lifetime Warranty. This Lifetime Warranty is only for U.S. consumers (defined herein as purchasers at retail for personal, family, or household use) who originally purchase the Product from Cuisinart or an authorized Cuisinart® reseller (if you are unsure whether a retailer or other point of sale is an authorized or unauthorized Cuisinart reseller, contact Cuisinart).

This Lifetime Warranty does NOT cover:

- Normal wear and tear;
- Any Tools & Gadgets purchased by commercial purchasers or for commercial or non-household uses;
- Accessories, parts, or software added to the Tools & Gadgets after the system is shipped from Cuisinart;
- Any costs associated with the replacement or repair of the Tools & Gadgets, including labor, installation, or other costs incurred by you without prior Cuisinart approval;
- Damage to the Tools & Gadgets, defective conditions, or nonconformities due to: (1) external causes, including shipping, accidents, problems with electrical power (Tools & Gadgets designed only for use with 120-volt outlets), abnormal conditions (such as mechanical or environmental); (2) usage not in accordance with Tools & Gadgets instructions; (3) misuse, neglect, unauthorized alteration, unauthorized repair; and (4) acts of god or other events beyond Cuisinart’s control;
- Though necessary repairs and maintenance might be performed by any company, damage caused by you or any nonauthorized third party may void, this Lifetime Warranty;
- Damage caused by accessories or replacement parts not specifically authorized by Cuisinart, may void this Lifetime Warranty; and
- Any Tools & Gadgets where the original Tools & Gadgets identification markings (trademark or serial number) have been removed, altered, or obliterated from the Product.

It is recommended that you visit the website, <https://cuisinart.registria.com>, for a fast, efficient way to complete your product registration. However, product registration does not eliminate the need for the consumer to maintain the original proof of purchase in order to obtain the warranty benefits. In the event that you do not have proof of purchase date, the purchase date for purposes of this Lifetime Warranty will be the date of manufacture.

HASSLE-FREE REPLACEMENT WARRANTY

If the Tools & Gadgets that is the subject of this Lifetime Warranty fails during the warranty period for reasons covered by this Lifetime Warranty, Cuisinart will, at its option, repair the Tools & Gadgets, replace the Tools & Gadgets with another identical or reasonably equivalent product, or if Cuisinart is unable to repair or replace the Tools & Gadgets, refund the purchase price, less the amount directly attributable to the consumer’s prior usage of the Tools & Gadgets. To obtain a return shipping label, email us at <https://www.cuisinart.com/customer-care/product-assistance/product-inquiry/>, or call our Consumer Service Center toll-free at **1-800-726-0190** to speak with a representative.

Upon receipt of the Tools & Gadgets, Cuisinart will inspect the Tools & Gadgets and, if required under this Lifetime Warranty, attempt to repair, replace, or refund the Tools & Gadgets within thirty (30) days. However, there may be delays beyond Cuisinart’s control, in which case that time period may be extended as reasonably necessary.

...continued next page

IMPORTANT: If the nonconforming Tools & Gadgets is to be serviced by someone other than Cuisinart's Authorized Service Center, please remind the servicer to call our Consumer Service Center at **1-800-726-0190** to ensure that the problem is properly diagnosed, the Tools & Gadgets is serviced with the correct parts, and the Tools & Gadgets is still under warranty.

CALIFORNIA RESIDENTS ONLY

The Lifetime Warranty period begins on the date the Tools & Gadgets was delivered, which may be different than the date the Tools & Gadgets was purchased. California residents also have the option of obtaining the benefits of this Lifetime Warranty by bringing the Tools & Gadgets to (A) the store where it was purchased or (B) another retail store that sells Cuisinart products of the same type. The retail store shall then, according to its preference, either repair the Tools & Gadgets, refer the consumer to an independent repair facility, replace the Tools & Gadgets with another identical or reasonably equivalent product, or refund the purchase price less the amount directly attributable to the consumer's prior usage of the Tools & Gadgets. California residents may also, according to their preference, return nonconforming products directly to Cuisinart for repair or, if necessary, replacement with another identical or reasonably equivalent product by calling our Consumer Service Center toll-free at **1-800-726-0190**. Cuisinart will be responsible for the cost of such repair, replacement, and/or shipping and handling for such nonconforming products under warranty.

THIS LIFETIME WARRANTY GIVES YOU SPECIFIC LEGAL RIGHTS, AND YOU MAY ALSO HAVE OTHER RIGHTS THAT VARY FROM STATE TO STATE OR BY JURISDICTION. IN THE EVENT THIS LIFETIME WARRANTY IS BREACHED, YOU MAY HAVE CLAIMS FOR REPLACEMENT, DAMAGES, OR OTHER PENALTIES

LIMITATIONS OF LIABILITY/ADDITIONAL LIMITATIONS AND EXCLUSIONS

ALL EXPRESS AND IMPLIED WARRANTIES ARE LIMITED IN DURATION TO THE LIFETIME WARRANTY PERIOD. NO WARRANTIES APPLY AFTER THAT PERIOD. SOME STATES DO NOT ALLOW LIMITATIONS ON HOW LONG AN IMPLIED WARRANTY LASTS, SO THIS LIMITATION MAY NOT APPLY TO YOU. CUISINART'S RESPONSIBILITY UNDER THIS OR ANY OTHER WARRANTY, IMPLIED OR EXPRESS, IS LIMITED TO REPAIR, REPLACEMENT, OR REFUND, AS SET FORTH ABOVE. THESE REMEDIES ARE THE SOLE AND EXCLUSIVE REMEDIES FOR ANY BREACH OF WARRANTY. TO THE MAXIMUM EXTENT PERMITTED BY LAW, CUISINART IS NOT RESPONSIBLE FOR ANY DIRECT, INDIRECT, SPECIAL, INCIDENTAL, OR CONSEQUENTIAL DAMAGES RESULTING FROM ANY BREACH OF WARRANTY OR UNDER ANY OTHER LEGAL THEORY (INCLUDING, BUT NOT LIMITED TO, LOST PROFITS, DOWNTIME, GOODWILL, DAMAGE TO OR REPLACEMENT OF EQUIPMENT AND PROPERTY, AND ANY COSTS OF RECOVERING, REPROGRAMMING, OR REPRODUCING ANY PROGRAM OR DATA STORED IN OR USED WITH A SYSTEM CONTAINING THE PRODUCT), EVEN IF CUISINART HAS BEEN ADVISED OF THE POSSIBILITY OF SUCH DAMAGES. SOME STATES DO NOT ALLOW THE EXCLUSION OR LIMITATION OF INCIDENTAL OR CONSEQUENTIAL DAMAGES, SO THE ABOVE LIMITATIONS OR EXCLUSIONS MAY NOT APPLY TO YOU. ALL EXPRESS AND IMPLIED WARRANTIES ARE LIMITED IN DURATION TO THE LIFETIME WARRANTY PERIOD. NO WARRANTIES APPLY AFTER THAT PERIOD. SOME STATES (OR JURISDICTIONS) DO NOT ALLOW LIMITATIONS ON HOW LONG AN IMPLIED WARRANTY LASTS, SO THIS LIMITATION MAY NOT APPLY TO YOU.

This Lifetime Warranty is issued by:

Conair LLC
1 Cummings Point Road
Stamford, CT 06902
1-800-726-0190

©2024 Cuisinart
Glendale, AZ 85307
Printed in China
23CT088682

IB-18152