

## CARE & MAINTENANCE

We stand behind the quality of our products, and because your safety and satisfaction are our top priority. Please review our safety notes below:

### CAUTION

- Be aware of pinch points which may occur on or around handles, latches, hinges, lids, and other moving components of the cooler.
- Avoid placing hands and fingers where injury or damage can occur. Injuries could occur if the handles, latches, hinges, lid, and other moving components on coolers are not used properly.
- Use safe practices on latches, handles, hinges when using them.
- Be aware that loose clothing and jewelry may also be caught in pivot areas of your cooler.
- Children should be supervised if present when using a cooler. Operate and maintain your cooler so it can be enjoyed for years to come!

### WARNING

Do not sit or stand on cooler. Do not place objects on cooler or use as a prep table. Heavy! Handle with care! Keep children away from assembly area!

### 1 Year Limited Warranty

**PROOF OF PURCHASE** is required to access this warranty program, which is in effect from the date of purchase. Customers will be subject to parts, and shipping and handling fees if unable to provide proof of the purchase or after the warranty has expired.

If you have any questions or problems, you can call our customer service department at 1-866-994-6390 from 9:00am to 5:00pm EST Monday through Friday or email [consumercare@thefulhamgroup.com](mailto:consumercare@thefulhamgroup.com), for assistance.

This limited warranty applies to the functionality of the product ONLY. It does not cover cosmetic issues such as scratches and dents, damage from abrasive or chemical cleaners or any tools used in the assembly or installation of the cooler cart, surface rust, or the discoloration of steel surfaces. Paint is not warranted and will require touch up. RUST is not considered a manufacturing or materials defect.

This limited warranty will not reimburse you for the cost of any inconvenience, food, personal injury or property damage.

### WARRANTY PROVISIONS

- This warranty is non-transferable and does not cover failures due to misuse, improper installation or maintenance.
- This warranty is for replacement of defective parts only. We are not responsible for incidental or consequential damages or labor costs.
- This warranty does not cover corrosion or discoloration after cooler is used, or lack of maintenance, hostile environment, accidents, alterations, abuse or neglect.
- This warranty does not cover damage caused by abrasive or chemical cleaners, or any damage to other components used in the installation or operation of the cooler cart.
- Paint is not warranted and may require touch-up.

### DISCLAIMER OF IMPLIED WARRANTIES; LIMITATION OF REMEDIES

Repair or replacement of defective parts is your exclusive remedy under the terms of this limited warranty. Manufacturer will not be responsible for any consequential or incidental damages arising from the breach of either this limited warranty or any applicable implied warranty, or for failure or damage resulting from acts of God, improper care and maintenance, accident, alteration, replacement of parts by anyone other than manufacturer, misuse, transportation, commercial use, abuse, hostile environments (inclement weather, acts of nature, animal tampering), improper installation or installation not in accordance with printed manufacturer instructions.

For replacement parts, call our customer service department at 1-866-994-6390 from 9:00am to 5:00pm EST, Monday through Friday or email [consumercare@thefulhamgroup.com](mailto:consumercare@thefulhamgroup.com) for assistance.

©2022 Cuisinart  
Cuisinart® is a registered trademark under license to The Fulham Group.  
Distributed by The Fulham Group, Newton, MA. 02466 U.S.A. MADE IN CHINA.  
Contact us at [consumercare@thefulhamgroup.com](mailto:consumercare@thefulhamgroup.com)  
One Year Limited Warranty.

Model # CCC-3517  
North American Distributor:  
The Fulham Group  
Newton, MA 02466

**Cuisinart**  
SAVOR THE GOOD LIFE

**Cuisinart**<sup>®</sup>  
GOURMET OUTDOOR GRILLING

**80 QT. OUTDOOR  
COOLER CART  
MODEL NO: CCC-3517**

OWNER'S MANUAL ASSEMBLY AND OPERATING INSTRUCTIONS

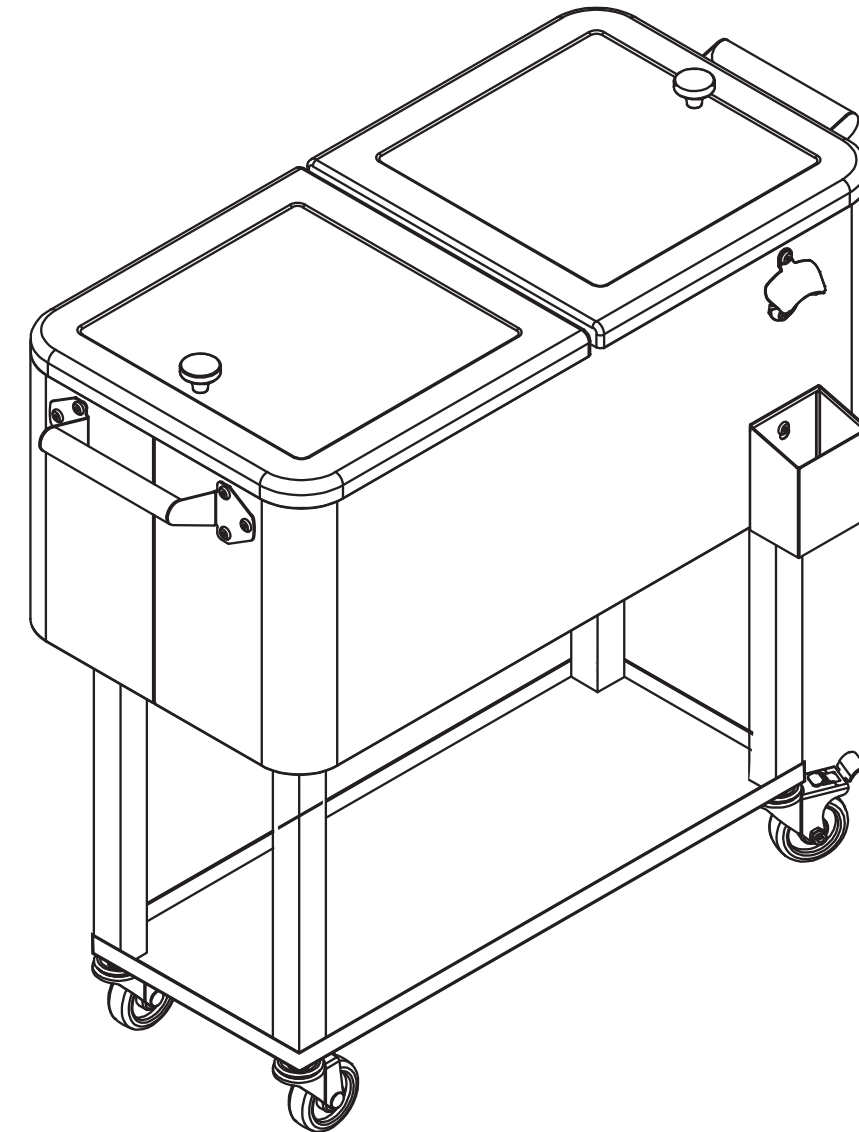

### ⚠ WARNING

SAVE THIS OWNER'S MANUAL FOR FUTURE REFERENCE.  
PLEASE READ THIS ENTIRE OWNER'S MANUAL BEFORE YOU USE YOUR NEW COOLER CART.

**Customer Service Hotline**  
**1-866-994-6390**

### DO NOT RETURN PRODUCT TO THE STORE

Before visiting your local retailer, please email [consumercare@thefulhamgroup.com](mailto:consumercare@thefulhamgroup.com), call 1-866-994-6390, or visit [www.thefulhamgroup.com](http://www.thefulhamgroup.com) to online chat with a representative. To best serve you, our Representatives are available to answer your calls and live chats Monday to Friday, 9 AM - 5 PM EST.

Get Social With Us @CuisinartBBQ    YouTube

See our full line of premium Cuisinart® Outdoor Cooking  
Products at [www.cuisinart.com/outdoorgrilling](http://www.cuisinart.com/outdoorgrilling)

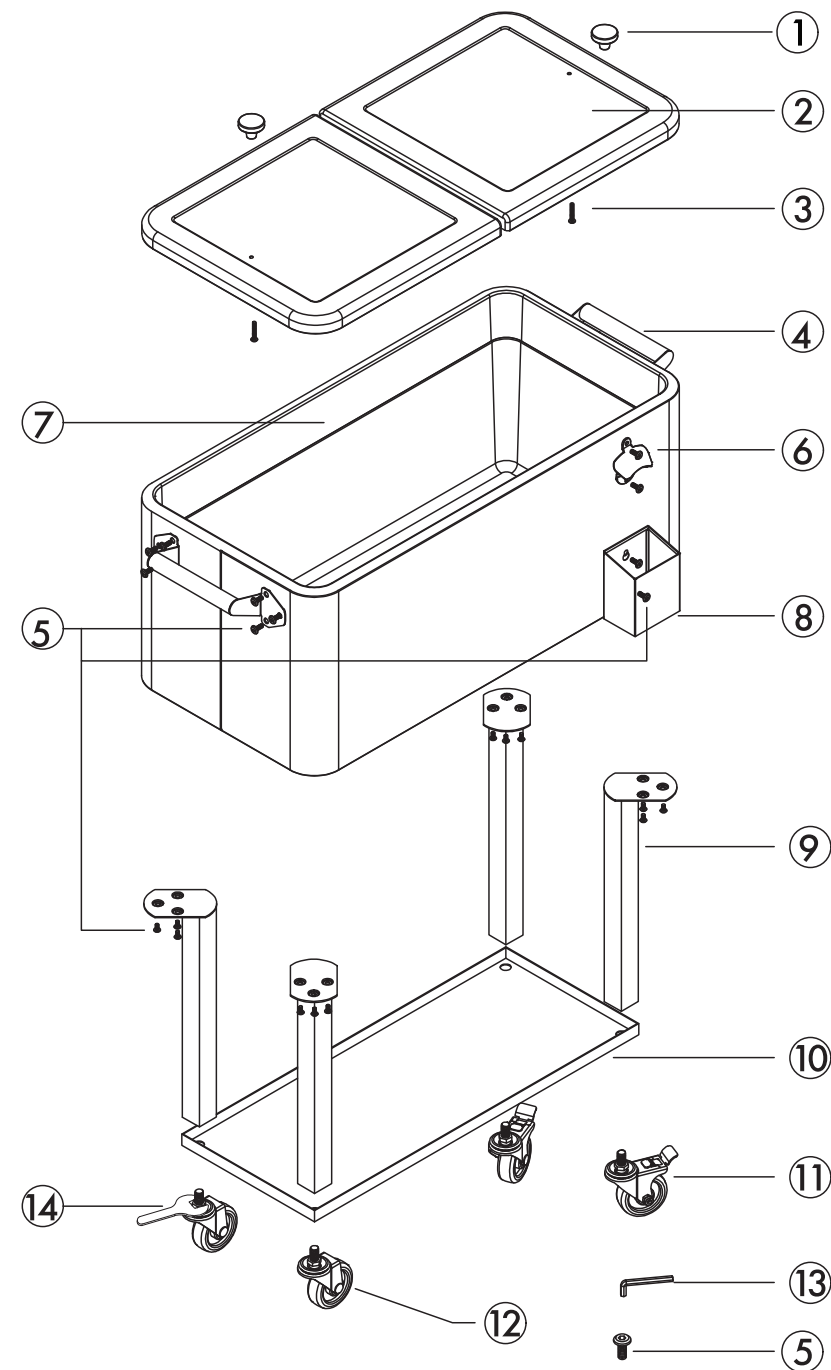

**THANK YOU FOR YOUR PURCHASE. PLEASE DON'T HESITATE TO CONTACT US WITH ANY PROBLEMS.**

**PLEASE READ THE COOLER CART MANUAL CAREFULLY AND ASSEMBLE ACCORDING TO FOLLOWING STEPS.**

**TOOLS REQUIRED: PHILLIPS SCREW DRIVER, ALLEN WRENCH (INCLUDED) & OPEN END WRENCH (INCLUDED).**

**CONFIRM ALL PARTS ARE PRESENT.**

1. Please make sure all parts are accounted for before beginning assembly.
2. Place main basin (part 7) up-side down on clean, soft surface .
3. Attach the 4 legs (part 9) to basin using 3 M6\*16 Bolts (part 5) per leg. Do not tighten these bolts until the Bottom Tray is assembled.
4. Place the bottom tray (part 10) over each leg and then screw each caster (parts 11 &12) into the legs with open end wrench (part 14). Tighten all leg bolts from previous step using M6 Allen Wrench (part 13).
5. Turn over entire assembly right side-up. Press caster brake lever to lock casters (part 11) and attach handle (part 4) to main basin using 6 M6\*16 bolts and tighten with M6 Allen Wrench. Repeat for opposite side handle.
6. Attach bottle-cap catcher (part 8) to main basin using 2 M6\*16 Bolts.
7. Attach bottle opener (part 6) to main basin using 2 M6\*16 bolts and tighten with M6 Allen Wrench.
8. Attach 2 lid knobs (part 1) to cooler lid (part 2) with M5\*35 bolts (part 3) and tighten with Phillips head screw driver. Note: Do not over tighten.
9. Clean inside of cooler completely with soft dry towel. Place cooler lid on top of main basin. Your cooler cart is now ready for use!

PART #	DESCRIPTION	QTY
1	Lid Knob	(x2)
2	Lid	(x1)
3	M5*35 Bolts (Lid Knob)	(x2)
4	Handle	(x2)
5	M6*16 Bolts	(x28)
6	Bottle Opener	(x1)
7	Basin	(x1)

PART #	DESCRIPTION	QTY
8	Bottle-cap Catcher	(x1)
9	Legs	(x4)
10	Bottom Tray	(x1)
11	Casters with Lock	(x2)
12	Casters without Lock	(x2)
13	M6 Allen Wrench	(x1)
14	17mm Open End Wrench	(x1)

#### CARE & MAINTENANCE

- Do not use harsh, abrasive cleaners, or other corrosive chemicals to clean any parts of the cooler cart.
- Use warm, soapy water to clean interior and exterior surfaces.
- To avoid scratching, do not use a scouring pad for cleaning any surfaces of the cooler cart.
- Drain water from the cooler after each use.
- Keep cooler cart dry when not in use and avoid damp environments when storing.
- Cooler cart should not be left outside unprotected in the elements.