

# Cuisinart® INSTRUCTION BOOKLET



Cuisinart® CleanWater™  
Countertop Filtration System

WCH-850

For your safety and continued enjoyment of this product, always read the instruction book carefully before using.

# IMPORTANT SAFEGUARDS

When using an electrical appliance, basic precautions should always be followed to reduce the risk of fire, electric shock, and personal injury, including the following:

1. Use this appliance only as described in this manual. Other uses not recommended may cause fire, electric shock or personal injury.
2. This product is intended for household use only.
3. To protect against electric shock, do not immerse unit, plug or cord in water or spray with liquids.
4. Close supervision is necessary when any appliance is used by or near children.
5. Unplug from the outlet when not in use or when moving from one location to another, and before cleaning.
6. To disconnect the appliance, grip the plug and pull it from the wall outlet. Never pull by the cord.
7. Do not operate the appliance in the presence of explosive and/or flammable fumes.
8. Do not place the appliance or any of its parts near an open flame, cooking or other heating appliance.
9. Do not operate the appliance with a damaged cord or plug, if the product malfunctions, or if it is dropped or damaged in any manner.
10. The use of attachments not recommended by the manufacturer may be hazardous.
11. Place the unit on a dry level surface.
12. Do not operate if the housing is removed or damaged.
13. A loose fit between the AC outlet (receptacle) and plug may cause overheating and a distortion of the plug. Contact a qualified electrician to replace loose or worn outlet.
14. This appliance is designed to be freestanding only, and should not be recessed or built in (fully recessed).
15. Locate the unit away from direct sunlight and sources of heat (stove, heater, radiator, etc.). Direct sunlight will affect/alter the outside color of the appliance.

16. Do not use with water that is microbiologically unsafe or of unknown quality without adequate disinfection before or after the system. Individuals requiring water of specific microbiological purity should consult their physician.

**NOTE:** The system and installation of this product needs to comply with state and local laws and regulations.

**WARNING:** To reduce the risk of fire, electric shock or personal injury, unplug or disconnect the appliance from the power supply before servicing.

## SAVE THESE INSTRUCTIONS FOR HOUSEHOLD USE ONLY

### SPECIAL CORD SET INSTRUCTIONS

For your protection, this unit is equipped with a 3-conductor cordset that has a molded 3-prong grounding-type plug, and should be used in combination with a properly connected grounding-type outlet as shown in figure A. If a grounding-type outlet is not available, an adapter, shown in Figure B, may be obtained so that a 2-slot wall outlet can be used with a 3-prong plug. As shown in Figure C, the adapter must be grounded by attaching its grounding lug under the screw of the outlet cover plate.

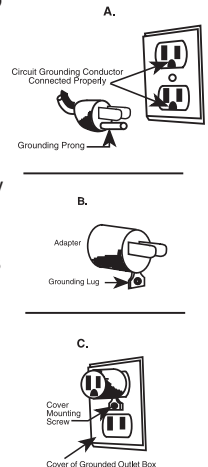

**NOTE:** Do not remove the grounding prong.

**CAUTION:** Before using an adapter, it must be determined that the outlet cover plate screw is properly grounded. If in doubt, consult a licensed electrician. Never use an adapter unless you are sure it is properly grounded.

**NOTE:** Use of an adapter is not permitted in Canada.

# CONTENTS

Important Safeguards . . . . .	2
Special Cord Set Instructions . . . . .	2
Introduction . . . . .	3
Parts and Features . . . . .	3
Before First Use . . . . .	4
Operating Instructions . . . . .	4
Tips and Hints . . . . .	5
Cleaning and Care . . . . .	5
Storing the Unit . . . . .	6
Technical Specifications . . . . .	6
Performance Data . . . . .	7
Warranty . . . . .	8

## 10. Brushed Stainless Steel Base

Durable stainless steel construction complements any décor.

## 11. Drainage Plug (not shown)

One removable plastic plug is located on bottom of unit.

## 12. Replacement Water Filter (Model GF-80)

The Cuisinart water filter has an optimum filter life of 3 to 4 months or 80 gallons.

# INTRODUCTION

Pour yourself a glass of fresh, clean, filtered water for a refreshing drink without opening the refrigerator or a bottle.

Your CleanWater™ Countertop Filtration System is Cuisinart at its most convenient. Drink healthy!

# PARTS AND FEATURES

## 1. 12-Week Filter Timer

Lets you know when to change your water filter.

## 2. Cover

Filp-top lid for easy filling.

## 3. Unfiltered/Upper Water Tank

## 4. Filtered/Lower Water Tank

## 5. On/Off Power Button

Press to power on. This will activate the chilling function.

## 6. Cold Water Button

Press to dispense chilled water.

## 7. Temperature Indicator Light

Blue LED lights up when water has reached cold temperature.

## 8. Room/Ambient Water Button

Press to dispense room temperature water.

## 9. Spigot

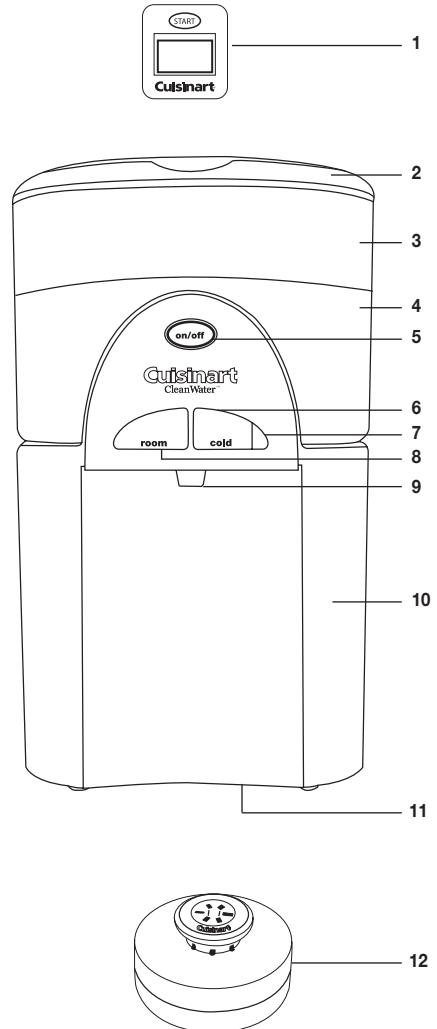

## BEFORE FIRST USE

Before using your Cuisinart® CleanWater™ Countertop Filtration System for the first time, it is recommended that the unit be flushed through with fresh water. Please be sure you read the following instructions before flushing your water dispenser.

**NOTE:** Do NOT plug the unit in or install the filter yet.

1. Remove your Cuisinart® CleanWater™ Countertop Filtration System carefully from the box. You may wish to store the packaging for future use.
2. Position the unit on a stable flat surface, close to a main power outlet, not in direct sunlight and out of the reach of children.
3. Make sure that there is sufficient space around the water dispenser to allow the heat extracted during the chilling process to dissipate. Allow at least 3" of space around the sides and rear of the unit for air circulation.
4. Lift the lid and, using a suitable jug, pour 1 gallon of tap water into the tank. While pouring the water, place a glass under the spigot and press the Room button to drain the water.

## OPERATING INSTRUCTIONS

### Installing the Water Filter

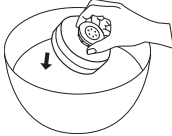
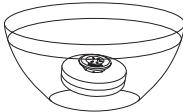
1. Remove the water filter from its packaging (it is normal for the filter to appear moist during storage). **DO NOT WASH FILTER ELEMENT WITH SOAP AND WATER.**
2. Place water filter into bowl in upright position with Cuisinart logo facing up. 
3. Add enough cold water to ensure that filter is fully submerged when pushed down. Hold filter upright, under water, and gently agitate it for 1 or 2 minutes or until you stop seeing bubbles rising to surface. Continue to soak filter for at least 15 minutes.   
**NOTE:** Filter may not completely sink to the bottom.

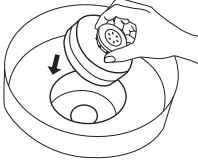
4. While the filter is soaking, remove the unfiltered/upper water tank and filtered/lower water tank. Wash both tanks and plastic lid in mild, soapy water, and rinse. **NOTE:** Remove filter timer before washing lid. Filter timer not immersible.
5. When filter is thoroughly soaked, lift it from bowl and allow water to drain. **NOTE:** The filter contains a small amount of loose carbon dust, which may make water appear dark during soaking – once the preparation process is complete, dust will be rinsed out of filter.
6. Insert the water filter (in upright position with Cuisinart logo facing up) into the upper water tank and push firmly into place. 
7. Hold the water tank with the filter in it under cold running tap water for 15 seconds to flush.
8. Let water drain from upper water tank into sink.
9. Fit the unfiltered/upper water tank onto the filtered/lower water tank and place cover on top. **NOTE:** The indent on the upper water tank must face to the back of unit when in place.
10. Place the reassembled tanks on the base.

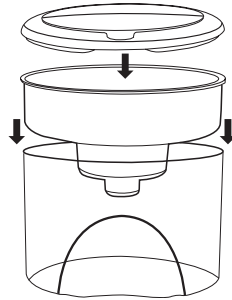

### Setting Up Your Cuisinart® CleanWater™ Countertop Filtration System

1. Lift the flip top lid, and using a clean pitcher, pour cold tap water into the unfiltered/upper water tank until full. **NOTE:** Only cold tap water is to be poured into the unit.
2. Allow approximately 15 minutes for water to filter into the filtered/lower water tank.

**NOTE:** Tank must be at least ½ full before proceeding to Step #3.

3. To allow internal cold water tank to fill, place glass under spigot and press and hold Cold button until water flows steadily (about 1 minute). **NOTE:** Until air is fully displaced by water, water flow will be a little erratic.
4. Close the lid.
5. Plug the unit into an electrical outlet. Press the On/Off power switch on the control panel to turn on. The blue light around the power switch indicates the unit is on and the cold feature is activated.
6. Dispense 16 ounces of room temperature water to remove any unfiltered water.
7. After approximately 1 hour the blue cold water indicator will light up signaling the water has chilled. Your Cuisinart™ CleanWater™ Countertop Filtration System is now ready for use.

**NOTE:** On subsequent fill-ups, unit may take up to 30 minutes to chill.

### Using the Filter Timer

It is important to change your water filter regularly to enjoy the full benefits of good tasting filtered water. The filter timer automatically reminds you when your water filter should be changed. For optimum results, it should be changed every 3 to 4 months, or 80 gallons.

Once the filter is in place and unit assembled, start the filter timer as follows:

1. On the cover, there is a filter timer that lets you know when to replace the filter.
2. Tear off the slip that insulates the battery. Peel off “Filtering” sticker from filter timer screen.
3. Press and hold the Start button until the word “Filtering” is displayed (approximately 3 seconds).
4. In 12 weeks, the word “REPLACE” will appear. We recommend replacing the filter with a new Cuisinart® Water Filter within the following 2 weeks, depending on usage. **NOTE:** Only the Cuisinart Replacement Filter (see next page) can be used with this unit.

5. Once you replace the filter, reset the timer by pressing the Start button. **NOTE:** If you do not replace the filter and press and hold Start button for 3 seconds, the timer will automatically shut off for power save and no display will be shown. You can press and hold Start button for 3 seconds anytime to reset the timer if needed. If you press Start button for more than 5 seconds the timer will automatically shut off for power save.

## TIPS AND HINTS

- Drinking 4 to 8 glasses of water each day is healthy! Your countertop chiller makes it easy.
- Regular use of clean, filtered water in your automatic coffeemaker means less frequent decalcification treatments.
- Use filtered water in your iron to reduce mineral build-up.
- Treat your pets to clean, filtered water.
- Clean, filtered water makes tea and instant soup or coffee taste better.

## CLEANING AND CARE

**CAUTION:** To prevent personal injury or electric shock, always unplug your Cuisinart® CleanWater™ Countertop Filtration System from outlet before cleaning. Do not immerse base in water or other liquid.

1. Turn the unit off and unplug it from outlet.
2. Remove the filter and place it in a bowl.
3. Lift upper water tank and let it drain into lower tank, and set it aside. Then lift lower tank off base and empty. Careful, a full tank can be very heavy!
4. Clean the water tanks and the cover with warm soapy water. **NOTE:** Remove filter timer before washing lid. Filter timer not immersible.
5. The base is not immersible. Simply wipe it clean with a damp cloth.
6. Dry thoroughly when clean.

## STORING THE UNIT

1. Turn the unit off and unplug it from outlet.
2. Remove empty water tanks, filter and cover.
3. Bring base to sink.
4. Drain internal reservoir by tilting unit slightly and removing the plastic drainage plug from bottom of unit. Plug is tightly inserted and must be gently, but firmly, worked to remove.
5. When water has completely drained, replace plug, tanks, filter and cover.
6. Your Cuisinart CleanWater™ Countertop Filtration System is ready to store.

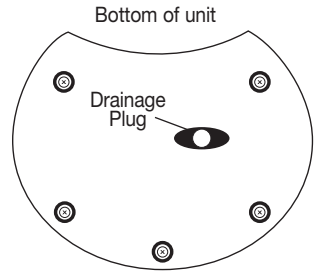

## TECHNICAL SPECIFICATIONS

### Unit:

**WCH-850**

1 Cuisinart® CleanWater™ Countertop Filtration System

1 Cuisinart® Water Filter

### System Capacity

up to 3-4 months/ 80 gallons/ 302 liters

### Maximum Temperature

85.0°F (29°C)

### Minimum Temperature

44.6°F (7°C)

### Rated Service Flow

10 gallons / 37.85 liters per day  
(may vary according to water conditions)



System Tested and Certified by NSF International against NSF/ANSI Standard 53 for the reduction of Benzene, Cadmium, Copper, Mercury, Tetrachloroethylene, Toluene, and Standard 42 for the reduction of Chlorine Taste and Odor.

See Performance Data Sheet for specific test conditions and results.

Claims are calculated based on NSF accepted practice of average percent reduction. The contaminants or other substances removed or reduced by this water treatment device are not necessarily in all users' water. Do not use with water that is microbiologically unsafe or of unknown quality without adequate disinfection before or after the system. Individuals requiring water of specific microbiological purity should consult their physician.

The Cuisinart® CleanWater™ Countertop Filtration System can process up to approximately 80 gallons/ 302 liters. When the Cuisinart® Water Filter (GF-80) exceeds filtering capacity, filter replacement is essential for the product to perform as represented. In the United States, replacement filters generally cost \$19.99 per filter. Replacement filters may be purchased at most retail outlets. The performance of the filter may vary based on local water conditions.

Hot water should not be used with the Cuisinart® Water Filter (GF-80) as it will affect the filter's performance.

Refer to the Operating Instructions and Cleaning and Care for general unit operation and maintenance requirements. Testing was performed under standard laboratory conditions; actual performance may vary.

# PERFORMANCE DATA SHEET

## PERFORMANCE DATA SHEET FOR MODELS WCH-850 AND WCH-950

### CONTAMINANT REMOVAL DATA IMPORTANT NOTICE:

Read this Performance Data Sheet and compare the capabilities of this unit with your actual water treatment needs. It is recommended that, before purchasing a water treatment unit, you have your water supply tested to determine your actual water treatment needs.

Performance testing conducted by NSF International. These systems have been tested according to NSF Standard 53 and 42 for reduction of the substances listed below. The concentration of the indicated substances in water entering the system was reduced to a concentration less than or equal to the permissible limit for the water leaving the system, as specified in NSF Standard 53.

Testing was performed under standard laboratory conditions, actual performance may vary.

			Removal	Removal	Action Level	Hardness	Temp	Inlet	
Substance	Influent Water Avg. (ug/L)	Influent Challenge Concentration (mg/L)	Filter Effluent Max. (ug/L)	Percent Reduction (%)	Max. Permissible Product Water Concentration (mg/L)	CaCO3 (ppm)	Testing Compart. (°C)	PH	Reduction Requirement
<b>NSF/ANSI Standard 42-Aesthetic Effects</b>									
Chlorine Taste and Odor Reduction	2.0	2.0+/-10%	N/A	97.5%	N.A.	N.A.	20	7.53	≥50
<b>NSF/ANSI Standard 53-Health Effects</b>									
Copper	3150	3.0+/-10%	870	85.0%	1.3	16	20	6.42	N/A
Copper	3100	3.0+/-10%	1000	85.4%	1.3	120	19	8.42	N/A
Mercury	6.2	0.006+/-10%	0.9	92.8%	0.002	22	19	6.45	N/A
Mercury	5.7	0.006+/-10%	1.2	89.9%	0.002	140	20	8.55	N/A
Cadmium	28.8	0.03+/-10%	2.2	96.6%	0.005	18	20	6.59	N/A
Cadmium	300	0.03+/-10%	4.0	92.5%	0.005	120	20	8.44	N/A
Benzene	15	0.015+/-10%	3.4	84.1%	0.005	130	20	7.58	N/A
Toluene	2900	3.0+/-10%	770	89.8%	1	320	20	7.54	N/A
Tetrachloroethylene	14	0.015+/-10%	3	92.5%	0.005	340	21	7.56	N/A

# WARRANTY

## LIMITED THREE-YEAR WARRANTY

This warranty is available to consumers only. You are a consumer if you own a Cuisinart® CleanWater™ Countertop Filtration System that was purchased at retail for personal, family or household use. Except as otherwise required under applicable law, this warranty is not available to retailers or other commercial purchasers or owners.

We warrant that your Cuisinart® CleanWater™ Countertop Filtration System will be free of defects in materials and workmanship under normal home use for 3 years from the date of original purchase.

We suggest you complete and return the enclosed product registration card promptly to facilitate verification of the date of original purchase. However, return of the product registration card does not eliminate the need for the consumer to maintain the original proof of purchase in order to obtain the warranty benefits. In the event that you do not have proof of purchase date, the purchase date for purposes of this warranty will be the date of manufacture.

If your Cuisinart® CleanWater™ Countertop Filtration System should prove to be defective within the warranty period, we will repair it, or if we think necessary, replace it.

To obtain warranty service, simply call our toll-free number 1-800-726-0190 for additional information from our Customer Service Representatives, or send the defective product to Customer Service at:

Cuisinart  
150 Milford Road  
East Windsor, NJ 08520.

To facilitate the speed and accuracy of your return, please enclose \$10.00 for shipping and handling of the product.

Please pay by check or money order (California residents need only supply proof of purchase and should call 1-800-726-0190 for shipping instructions).

**NOTE:** For added protection and secure handling of any Cuisinart® product that is being returned, we recommend you use a traceable, insured delivery service. Cuisinart cannot be held responsible for in-transit damage or for packages that are not delivered to us. Lost and/or damaged products are not covered under warranty. Please be sure to include your return address, daytime phone number, description of the product defect, product model number (located on bottom of product), original date of purchase, and any other information pertinent to the product's return.

Your Cuisinart® CleanWater™ Countertop Filtration System has been manufactured to the

strictest specifications and has been designed for use with the authorized accessories and replacement parts.

This warranty expressly excludes any defects or damages caused by accessories, replacement parts, or repair service other than those that have been authorized by Cuisinart.

This warranty does not cover any damage caused by accident, misuse, shipment or other ordinary household use.

This warranty excludes all incidental or consequential damages. Some states do not allow the exclusion or limitation of these damages, so they may not apply to you.

### CALIFORNIA RESIDENTS ONLY

California law provides that for In-Warranty Service, California residents have the option of returning a nonconforming product (A) to the store where it was purchased or (B) to another retail store which sells Cuisinart products of the same type.

The retail store shall then, at its discretion, either repair the product, refer the consumer to an independent repair facility, replace the product, or refund the purchase price less the amount directly attributable to the consumer's prior usage of the product. If the above two options do not result in the appropriate relief to the consumer, the consumer may then take the product to an independent repair facility if service or repair can be economically accomplished. Cuisinart and not the consumer will be responsible for the reasonable cost of such service, repair, replacement, or refund for nonconforming products under warranty.

California residents may also, according to their preference, return nonconforming products directly to Cuisinart for repair, or if necessary, replacement, by calling our Consumer Service Center toll-free at 1-800-726-0190.

Cuisinart will be responsible for the cost of the repair, replacement, and shipping and handling for such products under warranty.

### BEFORE RETURNING YOUR CUISINART® PRODUCT

If you are experiencing problems with your Cuisinart® product, we suggest that you call our Cuisinart® Service Center at 1-800-726-0190 before returning the product serviced. If servicing is needed, a Representative can confirm whether the product is under warranty and direct you to the nearest service location.

**Important:** If the nonconforming product is to be serviced by someone other than Cuisinart's Authorized Service Center, please remind the servicer to call our Consumer Service Center at 1-800-726-0190 to ensure that the problem is properly diagnosed, the product is serviced with the correct parts, and the product is still under warranty.



---

# PURCHASES MADE IN IOWA



*For purchases made in Iowa:*

This form must be signed and dated by the buyer and seller prior to consummation of this sale. This form should be retained on file by the seller for a minimum of two years.

**BUYER:**

**SELLER:**

\_\_\_\_\_  
Name

\_\_\_\_\_  
Name

\_\_\_\_\_  
Address

\_\_\_\_\_  
Address

\_\_\_\_\_  
City                      State              Zip

\_\_\_\_\_  
City                      State              Zip

\_\_\_\_\_  
Signature                                      Date

\_\_\_\_\_  
Signature                                      Date





# Cuisinart®

SAVOR THE GOOD LIFE™



Coffeemakers

Food Processors

Toasters

Rice Cookers

Cookware

Grills

Cuisinart offers an extensive assortment of top quality products to make life in the kitchen easier than ever. Try some of our other countertop appliances and cookware, and Savor the Good Life™.

**[www.cuisinart.com](http://www.cuisinart.com)**

©2007 Cuisinart  
Cuisinart® is a registered  
trademark of Cuisinart

150 Milford Road  
East Windsor, NJ 08520  
1-800-726-0190  
Printed in China

Any trademarks or service marks of third parties referred to herein are the trademarks or service marks of their respective owners.

07CU26171

G IB-7513

Version No.:	IB-7513
Fold Size:	140MMX216MM (12PP SADDLE STITCHED)
Material:	Cover: 157GSM MATT ARTPAPER Inside: 120GSM GLOSS ARTPAPER
Coating:	GLOSS VARNISHING IN COVER
Color (Cover):	4C(CMYK)+1C(BK)
(Inside):	1C(BK)+1C(BK)
Date:	AUG-17-2007
Co-ordinator :	Astor
Hugo Description:	WCH850 IB-7513(3,0) BOOK
Hugo Code:	AGL0002IB-1-1
Operator :	HUI

