

Cuisinart®

Outdoor Grilling Products

DELUXE WOOD PELLET GRILL & SMOKER

Model NO: CPG-700

OWNER'S MANUAL
ASSEMBLY AND
OPERATING INSTRUCTIONS

⚠ WARNING

PLEASE READ THIS ENTIRE MANUAL
BEFORE INSTALLATION AND USE
OF THIS PELLET FUEL-BURNING
APPLIANCE.

FAILURE TO FOLLOW THESE
INSTRUCTIONS COULD RESULT IN
PROPERTY DAMAGE, BODILY INJURY
OR EVEN DEATH.

CONTACT LOCAL BUILDING OR FIRE
OFFICIALS ABOUT RESTRICTIONS
AND INSTALLATION INSPECTION
REQUIREMENTS IN YOUR AREA.

NOTICE TO INSTALLER: LEAVE
THESE INSTRUCTIONS WITH
THE GRILL OWNER FOR FUTURE
REFERENCE.

SAVE THIS MANUAL FOR FUTURE
REFERENCE.



Customer Service Hotline

1-866-994-6390

DO NOT RETURN YOUR GRILL TO THE STORE

Before visiting your local retailer, call our customer service department at 1-866-994-6390
from 9:00 am to 5:00 pm Eastern Time, Monday through Friday
or email us consumercare@thefulhamgroup.com.

SAFETY INFORMATION

Warnings and Usage

IMPORTANT: ALL INSTRUCTIONS AND SAFEGUARDS ON THIS SECTION MUST BE FOLLOWED TO PREVENT DAMAGE AND/OR INJURY.

IMPORTANT SAFETY INFORMATION

⚠ WARNING: Never cover the cooking grates with foil or otherwise, it will restrict airflow and cause a hopper fire.

⚠ WARNING: For outdoor use only. Do not use near or inside a building, garage or any other enclosed area.

⚠ WARNING: A MAJOR CAUSE OF FIRES IS FAILURE TO MAINTAIN REQUIRED CLEARANCES (AIR SPACES) TO COMBUSTIBLE MATERIALS. IT IS OF UTMOST IMPORTANCE THAT THIS PRODUCT BE INSTALLED ONLY IN ACCORDANCE WITH THESE INSTRUCTIONS. Keep all combustible materials at least 60 inches (152.4 cm) away from the grill at all times. This includes combustible overhangs, and combustible flooring like a wooden deck.

⚠ WARNING: This product is an electrical device utilizing hazardous voltage levels and must be operated away from water. If water contacts the power cord or sensitive electronics serious damage to the product or electrocution risk may occur. Do not operate this product in rain or wet conditions. Do not allow this product to come in contact with water. Set this product up more than 10' from any large body of water (swimming pool, lake, pond, etc).

⚠ WARNING: Carbon monoxide is a colorless, odorless gas produced by burning common cooking fuels like wood, charcoal, and propane. Follow these guidelines to prevent this colorless, odorless gas from poisoning you, your family, or others:

- Know the symptoms of carbon monoxide poisoning; headache, dizziness, weakness, nausea, vomiting, sleepiness and confusion. Carbon monoxide reduces the blood's ability to carry oxygen. Low blood oxygen levels can result in loss of consciousness and death.
- See a doctor if you or others develop cold or flu-like symptoms while cooking or in the vicinity of this appliance. Carbon monoxide poisoning, which can easily be mistaken for a cold or flu, is often detected too late.
- Alcohol consumption and drug use increase the effects of carbon monoxide poisoning.
- Carbon monoxide is especially toxic to mother and child during pregnancy, infants, the elderly, grills and people with blood or circulatory system problems, such as anemia or heart disease.

⚠ DANGER: NOT for use in or on boats or recreational vehicles.

⚠ DANGER: Do not store or use flammable liquids near the grill.

⚠ DANGER: Only use this product with a GFI protected 3 prong outlet.

TABLE OF CONTENTS

Cover.....	1
Safety Information.....	2
Table of Contents.....	3
Exploded View.....	5
Parts List.....	6
Assembly Preparation and Instructions.....	8
Operating the Grill.....	21
Cooking.....	25
Care and Maintenance.....	28
Trouble Shooting.....	31
Warranty and Replacement Parts.....	33

GENERAL WARNINGS







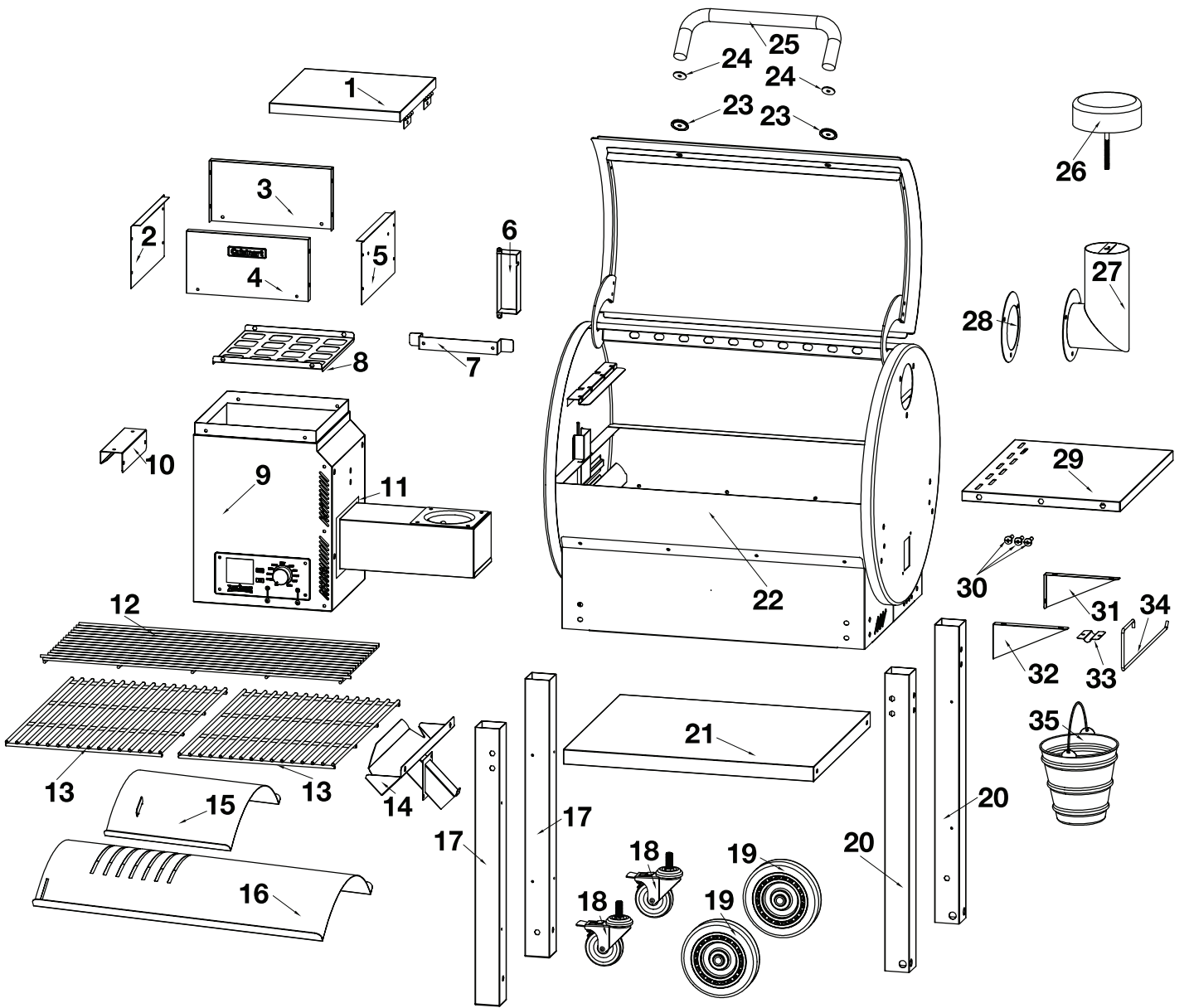











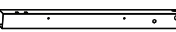

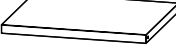
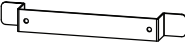

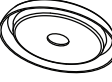
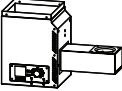
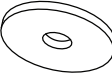
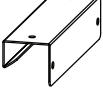

- **DO NOT** use on wood decks. Set up this grill on a hard, non-combustible smooth level surface.
- In case of fire, turn the control “OFF” and allow the fire to burn out on its own. Do not unplug the grill or use water to try to extinguish the fire. If you feel the fire is beyond your control call the fire department.
- Keep a fire extinguisher on hand acceptable for use with electric products. Refer to your local authority to determine proper size and type.
- Creosote – Formation and need for removal. When wood pellets are burned slowly, they produce tar and other organic vapors that combine with expelled moisture to form creosote. The creosote vapors condense on relatively cooler surfaces like the exhaust vents and the glass. As a result, creosote residue accumulates on these surfaces. When ignited, this creosote makes an extremely hot fire. To prevent this do a deep clean on the internal components of the grill at least twice a year. See Care and Maintenance Section.
- Keep appliance clean. When grease or creosote has accumulated, it should be cleaned to reduce risk of fire. See Care and Maintenance section.
- The surfaces of the grill will get very hot during regular use and can be a burn hazard. Do not leave unattended when children are present and keep away from combustible materials.
- To avoid accidental burns wear heat resistant mitts, use long handled tools, handles, and knobs when operating the grill.
- To protect against electric shock, do not immerse cord, plugs, or heating element in water or any other liquids.
- Do not place power cord where it may come in contact with hot surfaces or pose a tripping hazard.
- Unplug this grill from the power source when not in use and before cleaning. Allow appliance to cool down before attempting to clean or service.
- Do not operate any appliance with a damaged power cord or plug, or after the appliance has malfunctioned or been damaged in any manner.
- **NEVER** add cooking pellets to a hot fire pot by hand. You could be seriously burned. If the hopper runs out of pellets or your fire goes out while cooking, let the grill completely cool and follow the Initial Lighting Instructions.
- Use only cooking grade wood pellets. **NEVER** use heating grade wood pellets as they are not safe for cooking.
- **NEVER** use gasoline, gasoline-type lantern fuel, kerosene, charcoal lighter fluid, or similar liquids to start or “freshen up” a fire in this appliance. Keep all such liquids well away from the appliance when in use.
- Outdoor extension cords must be used with outdoor use products and are marked with suffix “W” and with the statement “Suitable for Use with Outdoor Appliances.”
- Use only with a properly grounded GFI (Ground Fault Interrupter) household circuit.
- Do not attempt to move this appliance while it is in use.
- After a period of storage, inspect the grill for abrasion, wear, cuts, or damage to the temperature controller and power cord.
- Before covering your grill make sure that the grill has cooled completely.
- Do not operate this grill while under the influence of drugs, alcohol, or while fatigued.
- Do not use this grill unless it is completely assembled, and all parts are securely fastened and tightened.



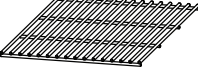

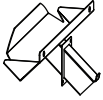
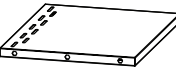
EXPLODED VIEW











PARTS

PART		DESCRIPTION	QTY	PART		DESCRIPTION	QTY
1		Hopper Lid	(x1)	16		Drip Shield	(x1)
2		Hopper top left panel	(x1)	17		Legs, Hopper Side	(x2)
3		Hopper top back panel	(x1)	18		Locking Caster	(x2)
4		Hopper top front panel	(x1)	19		Wheel	(x2)
5		Hopper top right panel	(x1)	20		Legs, Shelf Side	(x2)
6		Temperature Probe Cover	(x1)	21		Bottom Shelf	(x1)
7		Cord Wrap	(x1)	22		Main Body	(x1)
8		Hopper Grate	(x1)	23		Lid Handle Bezel	(x2)
9		Hopper Body	(x1)	24		Insulation Washer	(x2)
10		Handle	(x1)	25		Lid Handle	(x1)
11		Hopper Gasket	(x1)	26		Chimney Cap	(x1)
12		Upper Cooking Rack	(x1)	27		Chimney	(x1)
13		Cooking Grid	(x2)	28		Chimney Gasket	(x1)
14		Grease Channel	(x1)	29		Side Shelf	(x1)
15		Sear Shutter	(x1)	30		Tool Hooks	(x3)

PARTS

PART		DESCRIPTION	QTY	PART		DESCRIPTION	QTY
31		Side Shelf Bracket (right)	(x1)	34		Paper Towel Rod	(x1)
32		Side Shelf Bracket (left)	(x1)	35		Grease Bucket	(x1)
33		Paper Towel Bracket	(x1)				

HARDWARE

PART		DESCRIPTION	QTY	PART		DESCRIPTION	QTY
A		Phillips Head Screw 1/4" x 5/8"	(x26)	F		Wheel Washer	(x2)
B		Flat Washer 1/4"	(x30)	G		Phillips Head Screw 5/32" x 1/2"	(x18)
C		Lock Washer 1/4"	(x30)	H		Lock Nut 5/32"	(x4)
D		Wheel Pin	(x2)	I		Phillips Head Screw 1/4" x 3/4"	(x4)
E		Cotter Pin	(x2)				

ASSEMBLY PREPARATION

Some parts may contain sharp edges. Wear protective gloves during assembly and set up. Read and follow all safety statements, warnings, assembly instructions and use and care instructions before attempting to assemble and use.

Before you Begin: Unpack all the components and verify that everything is present before beginning assembly. **Several components are packed inside the cooking chamber, it is important to remove these as well.** If any part is missing or damaged, DO NOT attempt to assemble the product.

Estimated assembly time: 1 hour.

NOTE: During assembly two people will be required to lift the Main Body (22) onto the cart.

Tools required for assembly: Wrench, Phillips Head Screwdriver and Gloves (NO TOOLS ARE INCLUDED).

NO TOOLS ARE
INCLUDED

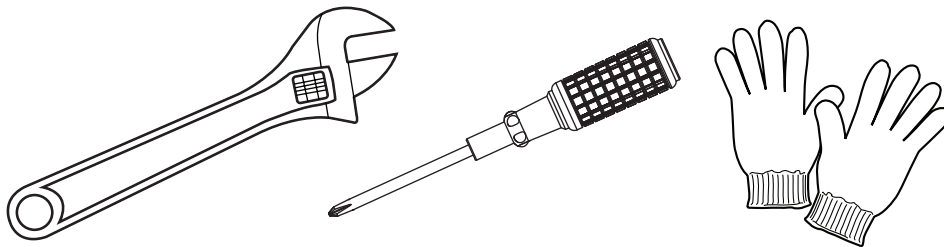

ASSEMBLY INSTRUCTIONS

Assembly Tip: To avoid scratching grill and to protect floor/patio surfaces, reuse cardboard packaging and lay parts on top of while assembling.

STEP 1 - ATTACHING LEGS TO MAIN BARREL

- Lay cardboard or packaging foam on the floor and place the Main Barrel (22) upside down on top of it.
- Insert the 4 (17,20) legs as shown ensuring the holes are facing the correct directions. Attach the legs using the Screw (A), Lock Washer (B), Washer (C) assemblies as shown.

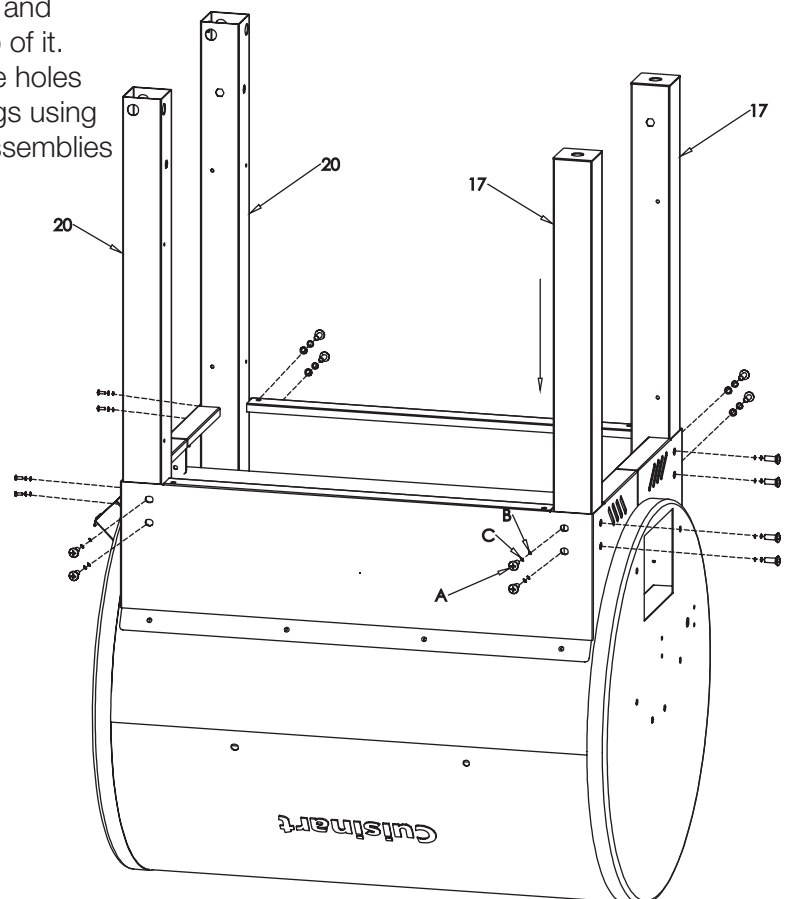
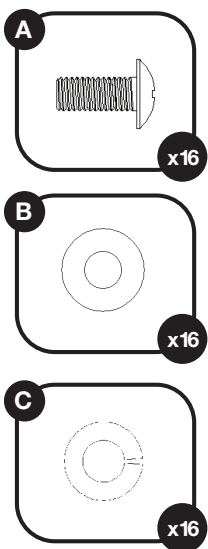

ASSEMBLY INSTRUCTIONS

STEP 2 - ATTACHING LEGS TO MAIN BARREL

- Attach the Bottom Shelf (21) to the legs using four sets of Screw (A), Lock Washer (B), and Washer (C), as shown. If the screw holes do not line up, the legs may have been attached incorrectly in Step 1.

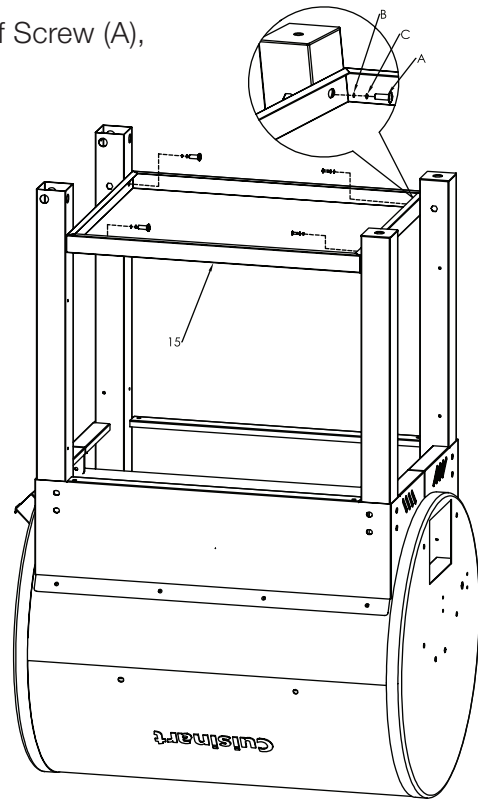
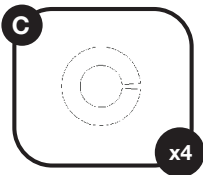
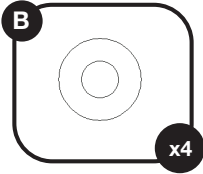
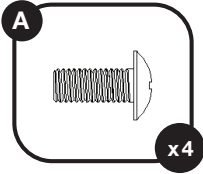

STEP 3 - ATTACHING WHEELS

- Attach the two Locking Casters (18) to the Legs (17). Hand tightening is sufficient. You can adjust these casters later to ensure the grill is level with the floor.
- Attach the two Wheels (19) to the Legs (20) by inserting the Wheel Pin (D) through the wheel and leg. Place the Wheel Washer (F) on the opposite side and secure it with the Cotter Pin (E), as shown in the picture.

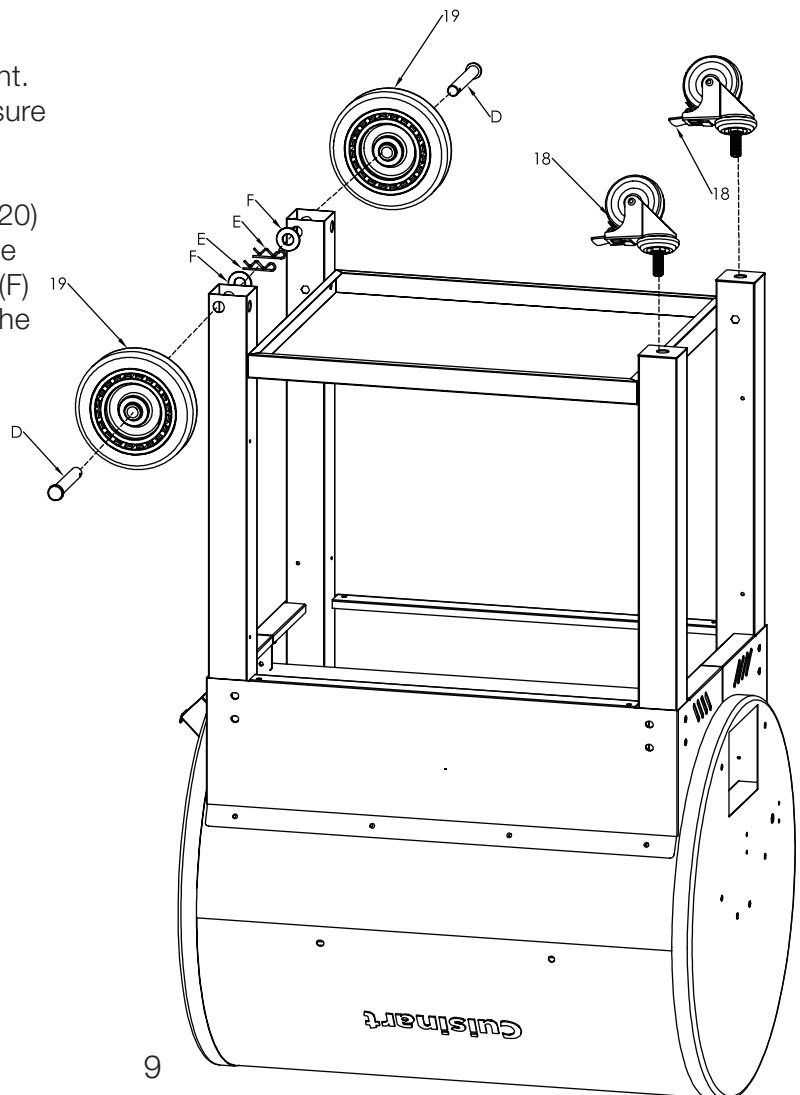
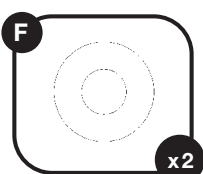
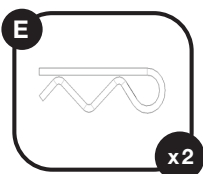
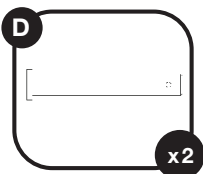

ASSEMBLY INSTRUCTIONS

STEP 4 - GREASE CHANNEL

- Ensure all screws from the previous steps are tight, then turn the grill over to stand on the wheels.
- **NOTE:** It is recommended to perform this step with two people.

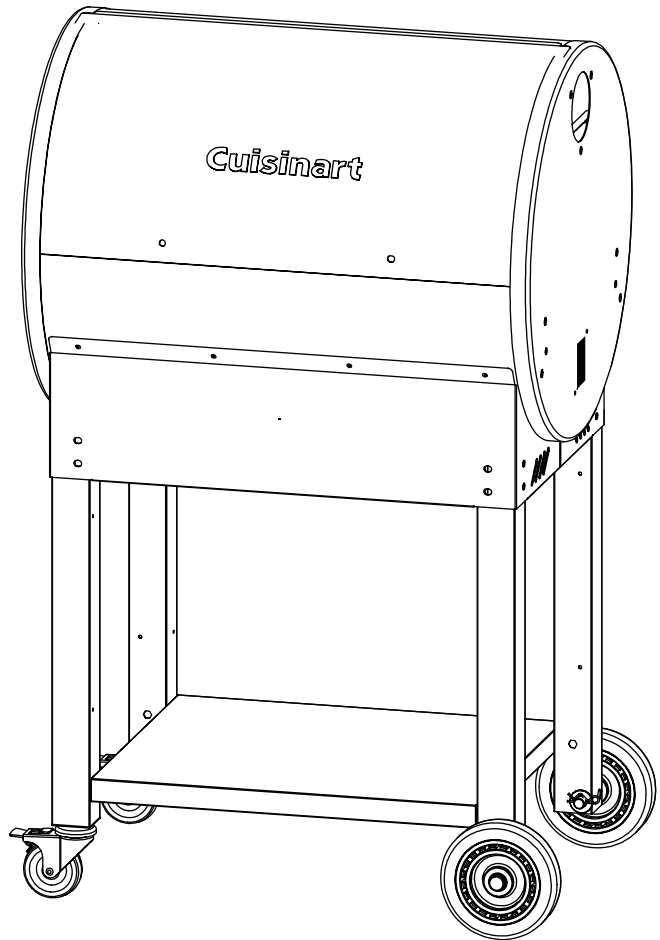

STEP 5 - INSTALLING THE GREASE CHANNEL

- Open the lid and insert the Grease Channel (14) drain into the rectangular hole on the side of the grill.
- Attach the grease channel to the body using two sets of Screws (A) with Washer (B) and Lock Washer (C).
- Secure the grease drain to the body using two Screws (G) and two Lock Nuts (H) going through the two diagonal holes on the corners of the drain. The “star” side of the nuts should face the screws.

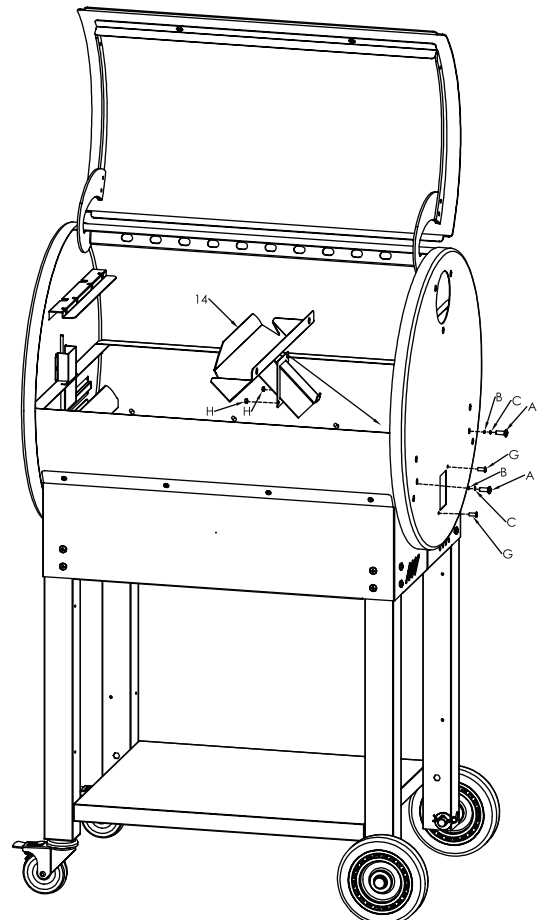
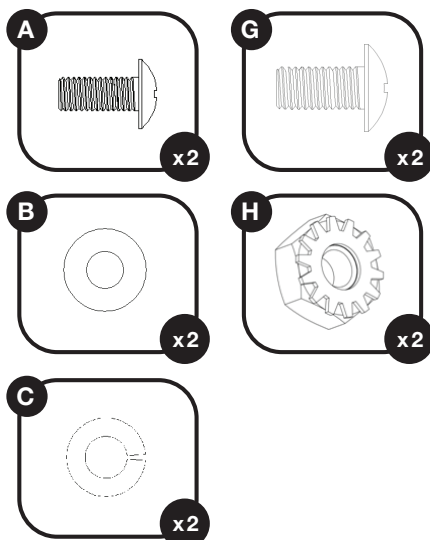

ASSEMBLY INSTRUCTIONS

STEP 6 - ATTACHING TOOL HOOKS

- Attach the three Tool Hooks (30) to the Side Shelf (29).

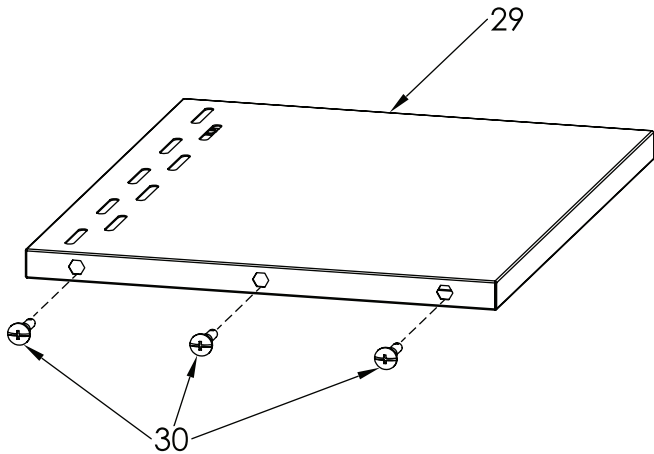

STEP 7 - SIDE SHELF ASSEMBLY

- Attach the Side Shelf Bracket Left (32) and Side Shelf Bracket Right (31) to the bottom of the Side Shelf using Screws (A) Washers (B) and Lock Washers (C) as shown in the image.

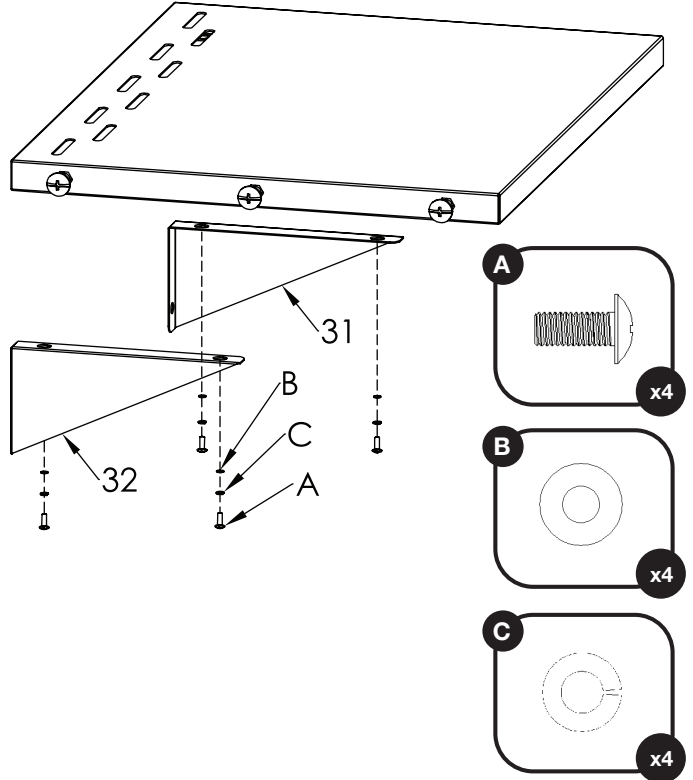

STEP 8 - PAPER TOWEL ROD

- Place the Paper Towel Rod (34) into the Paper Towel Bracket (33) and attach it to the bottom of the side shelf using two Screws (G).

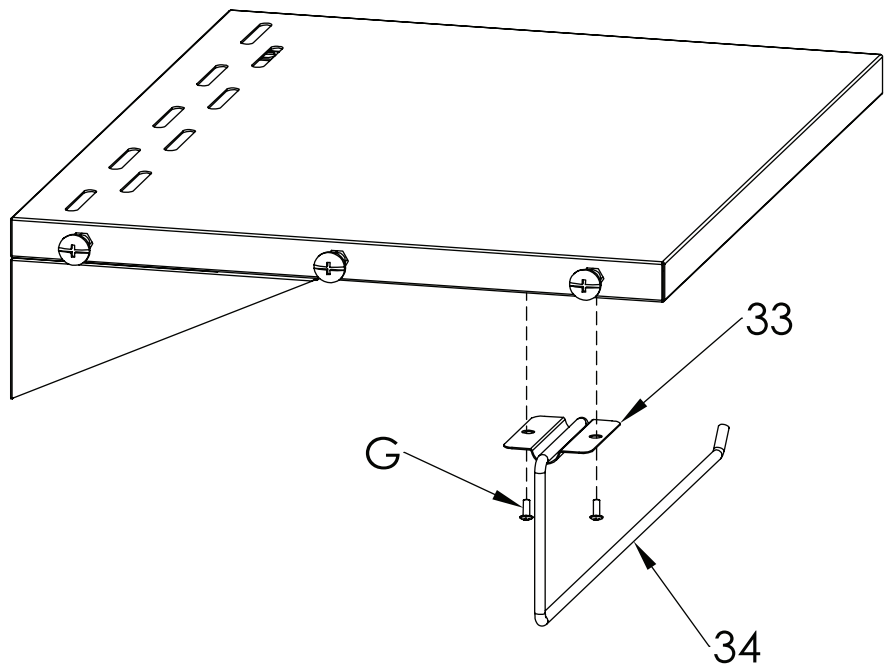
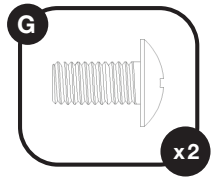

ASSEMBLY INSTRUCTIONS

STEP 9 - SIDE SHELF

- There are four sets of pre-installed screws with washers on the side of the grill body. Remove these and use them to attach the side shelf to the Grill Body through the same holes.
- **NOTE:** Do not accidentally remove the two screws that were installed earlier to secure the Grease Channel.

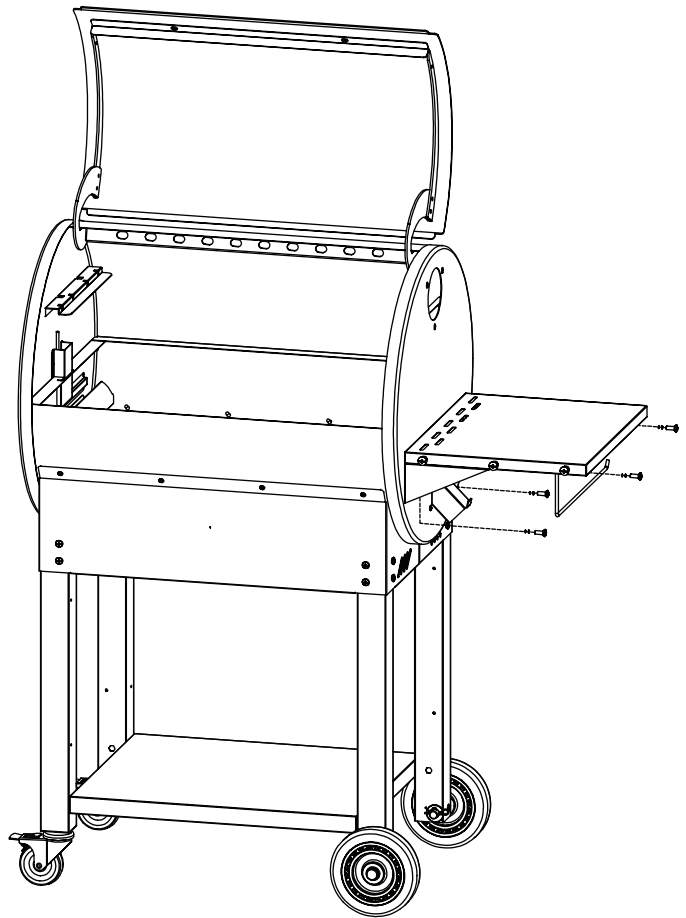

STEP 10 - HANDLE

- Remove the pre installed screws from the Handle (25).
- Attach the handle to the lid with the screws coming out from the inside of the lid going through first the Handle Bezel (23) then the Insulating Washer (24) and finally threading into the Handle (25).

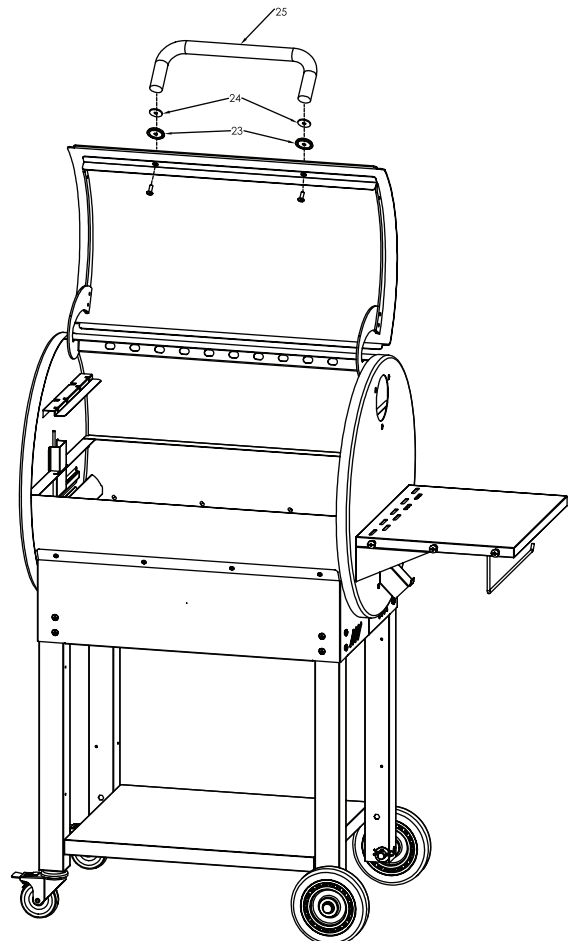

ASSEMBLY INSTRUCTIONS

STEP 11 - CHIMNEY

- Remove the three sets of pre installed screws around the exhaust hole
- Place the Chimney Gasket (29) on the grill body around the exhaust, ensuring the three holes line up.
- Install the Chimney (27) to the grill using the three screw assemblies that were removed just before.

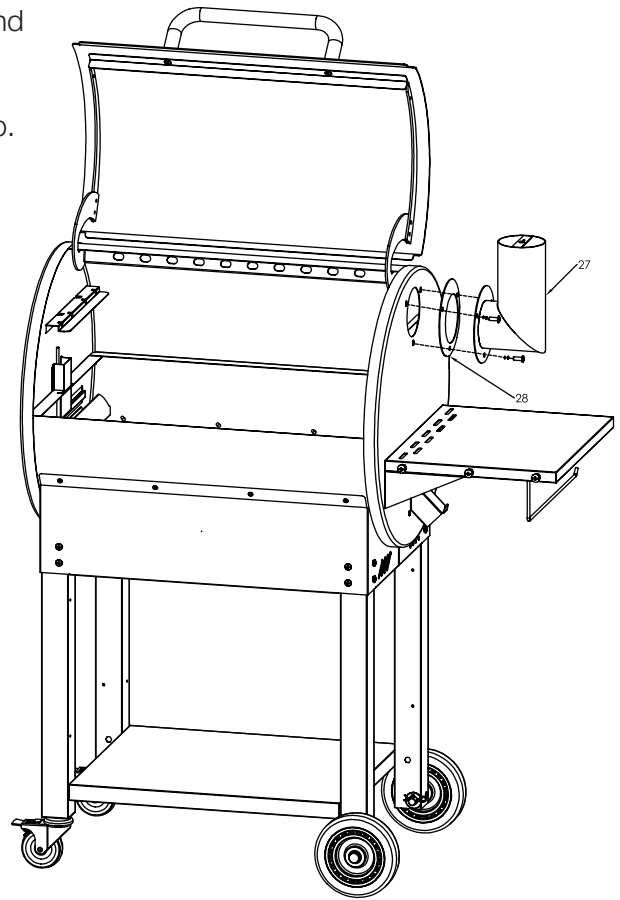

STEP 12 - CHIMNEY

- Screw the Chimney Cap(26) onto the top of the Chimney.

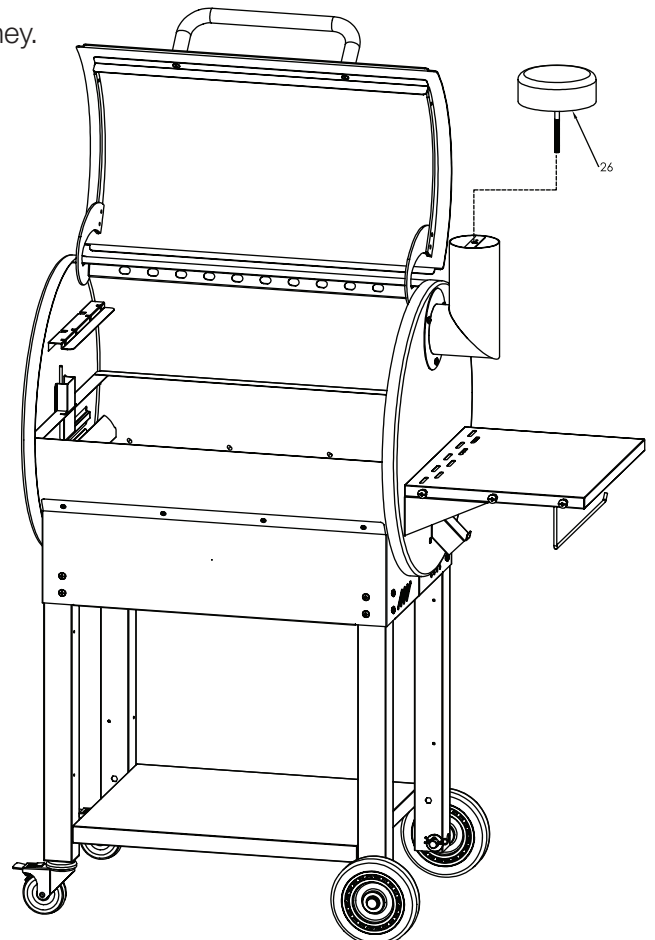

ASSEMBLY INSTRUCTIONS

STEP 13 - HOPPER

- Assemble the top section of the hopper as shown. Note the positions of Panels (2), (3), (4), and (5). Secure the panels to each other using 8 Screws (G).

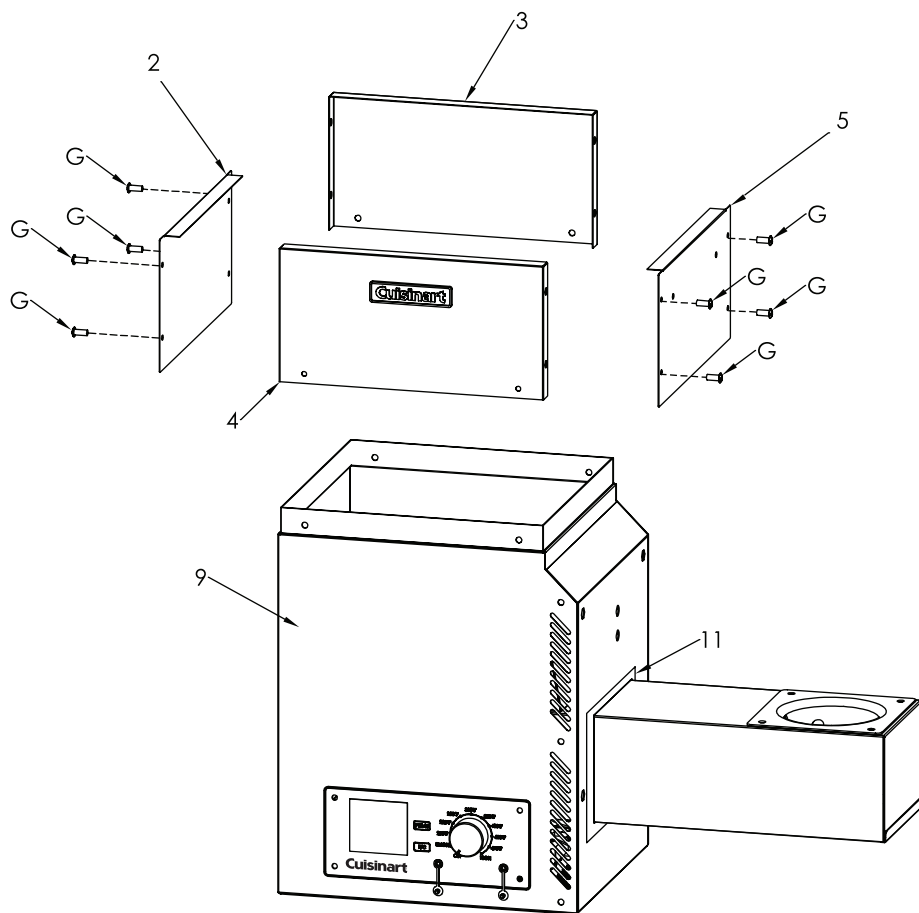
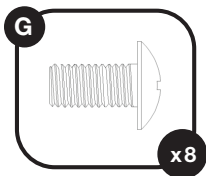

STEP 14 - HOPPER

- Insert the Hopper Grate (8) into the hopper ensuring the four threaded holes line up with the holes on the front and back of the hopper.
- Secure the upper hopper assembly to the Hopper Body (9) with four Screws (G) by threading them into the Hopper Grate (8).

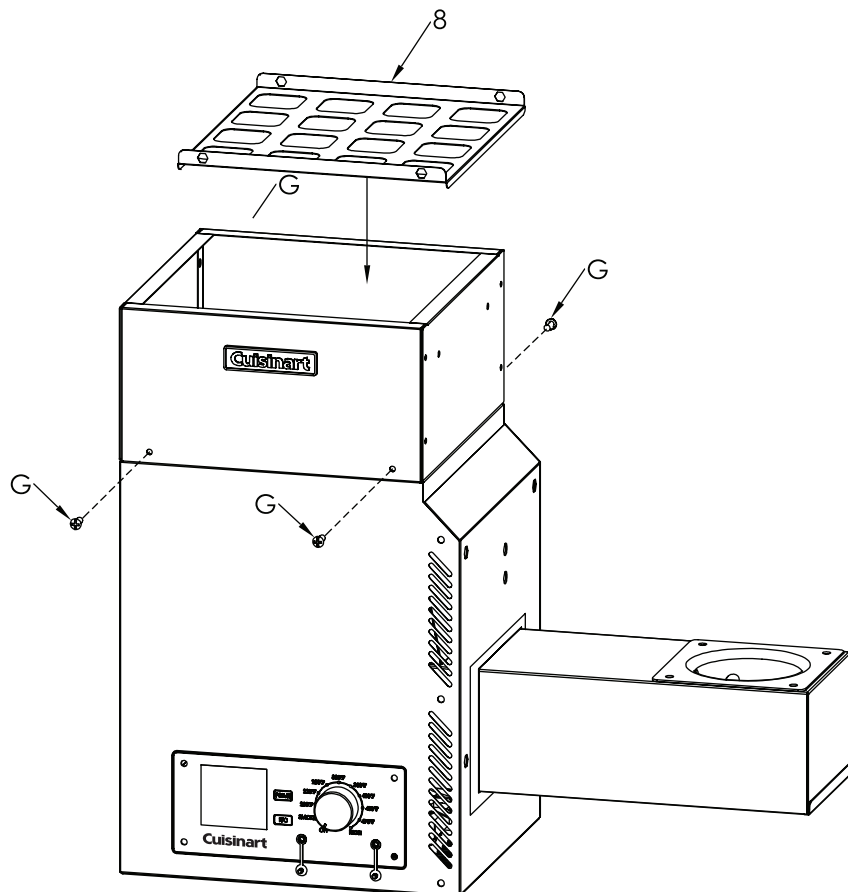
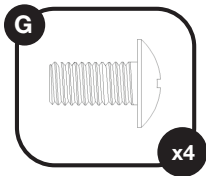

ASSEMBLY INSTRUCTIONS

STEP 15 - HOPPER

- Attach the hopper lid to the hopper by securing it with two Screws(G) and two Lock Nuts (H).

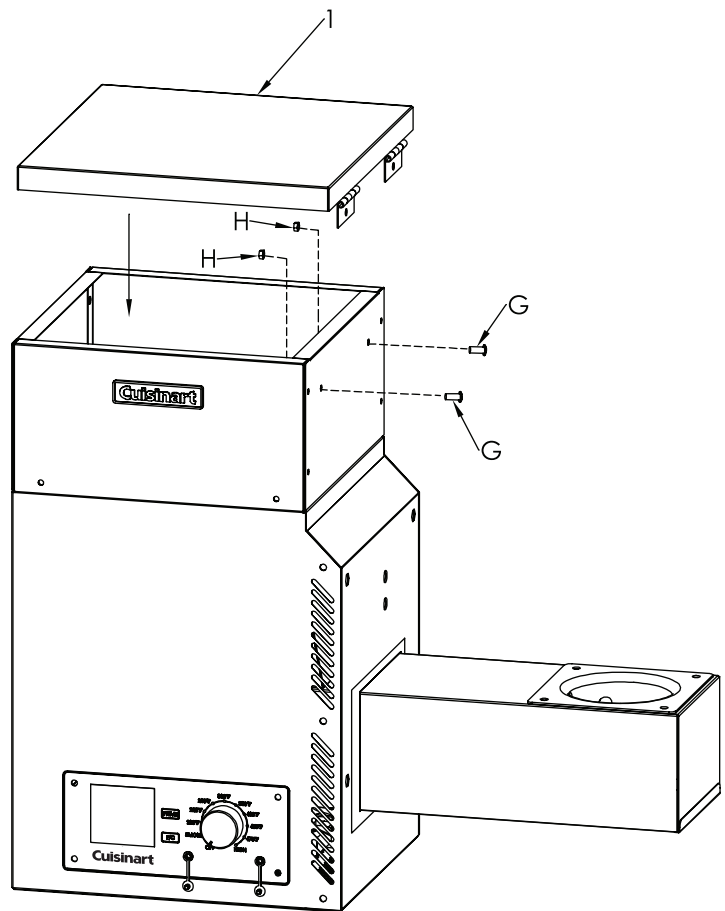
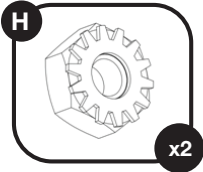
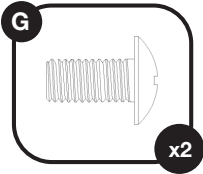

STEP 16 - HOPPER

- Remove the two pre installed screws on the side of the hopper and use them to attach the Handle (10).

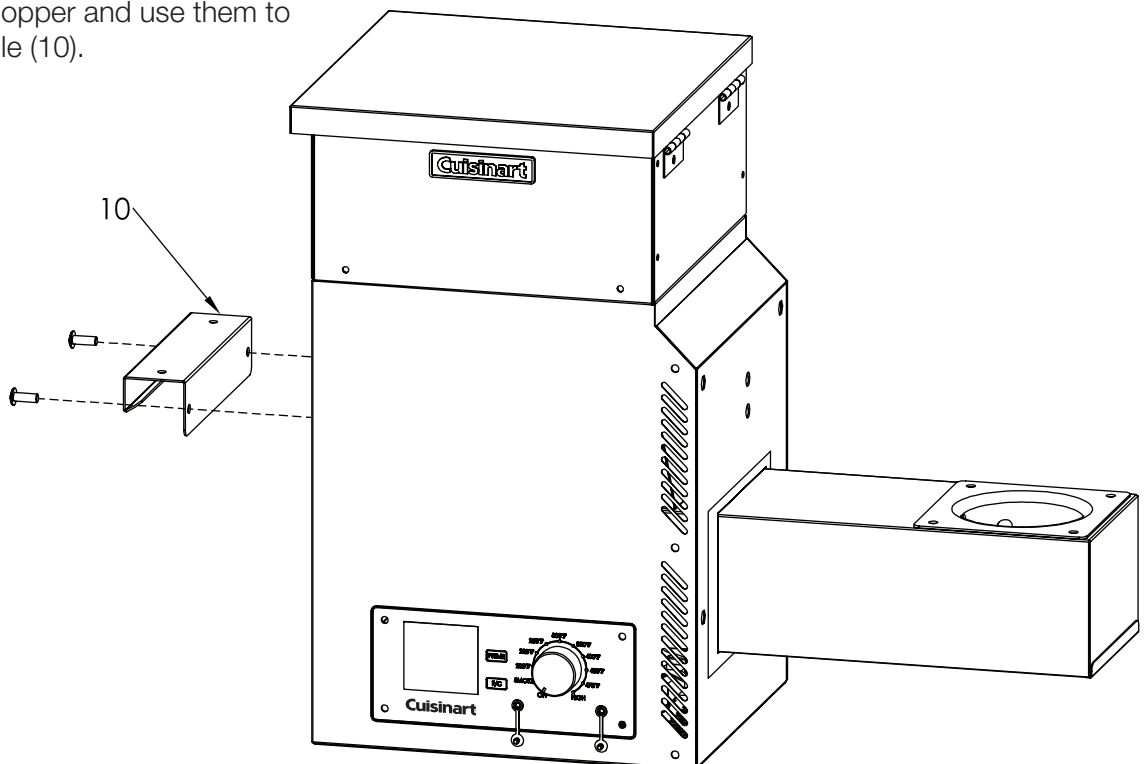

ASSEMBLY INSTRUCTIONS

STEP 17 - HOPPER

- Remove the two pre installed screws on the back of the hopper and use them to attach the Cord Wrap (7).

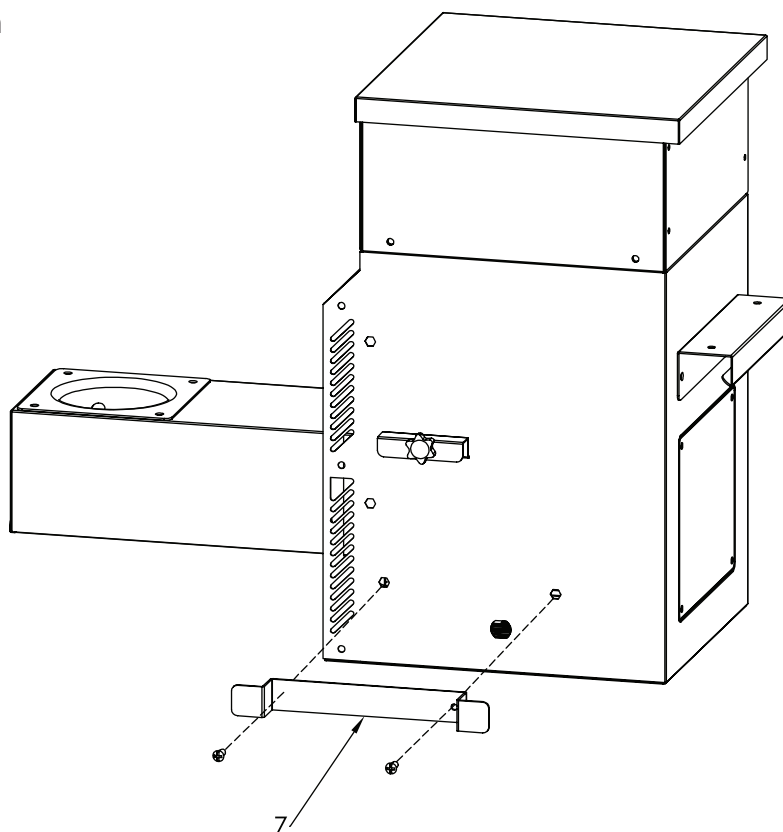

STEP 18 - HOPPER INSTALLATION

- Insert the hopper into the rectangular hole on the side of grill body, ensure the four holes shown in the bubble line up with the four threads on the hopper body.
- Attach the hopper to the body using four Screws (I) paired with Washers (C) and Lock Washers (B). It is recommended to perform this step with two people, one person to hold the hopper up while the other person installs the screws. Installing the top two screws first will make things easier.
- NOTE:** Screw (I) is longer than the Screw (A) that have been used in previous steps.

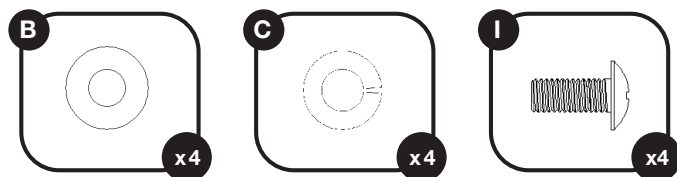
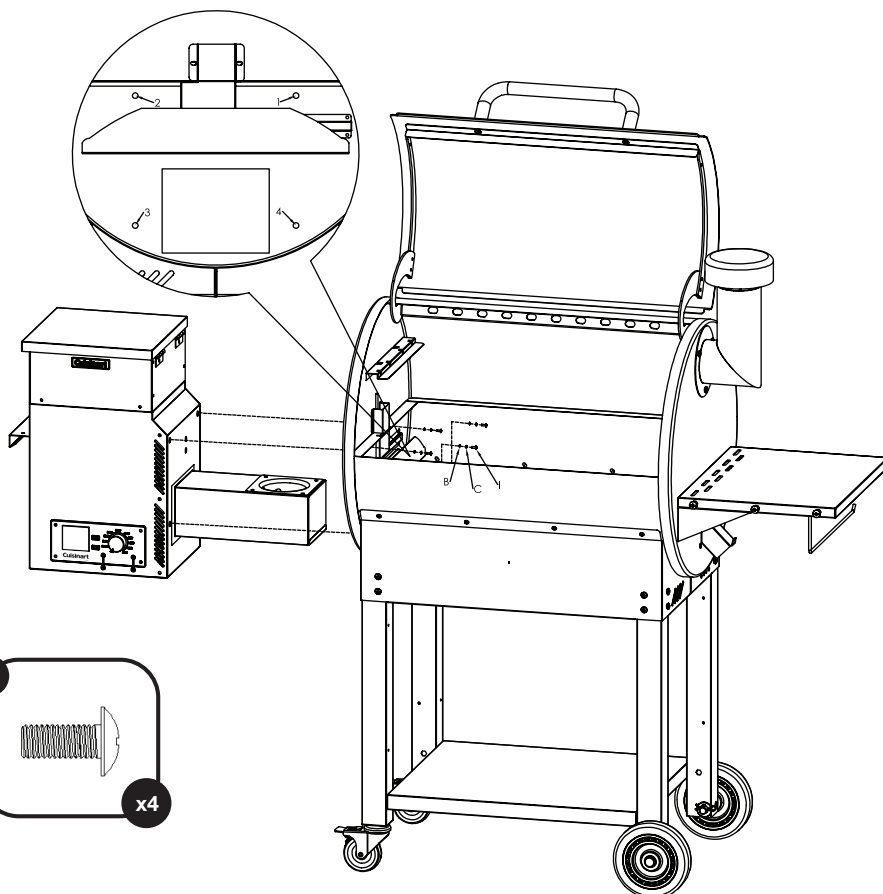

ASSEMBLY INSTRUCTIONS

STEP 19 - HOPPER INSTALLATION

- Connect the Temperature Probe connectors at the back of the hopper.
- Remove the pre-installed screws from the back of the hopper and use them to attach the Temperature Probe Cover (6). Ensure the wire and connector are safely contained inside the cover without any pinching.

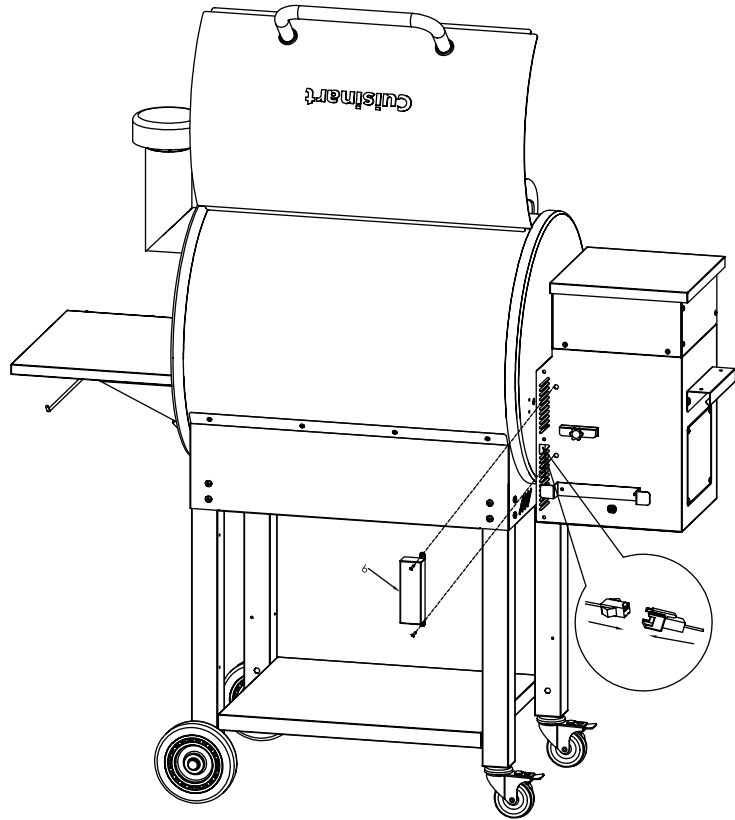

STEP 20 - INTERNAL COMPONENTS

- Insert the Drip Shield (16) into the main body as shown. The slats of the Drip Shield (16) should be directly above the fire pot. The drip shield slots into two tabs on the left side and rests on top of the Grease Channel on the right side tilting down towards it.
- Place the Sear Shutter (15) on top of the slats.

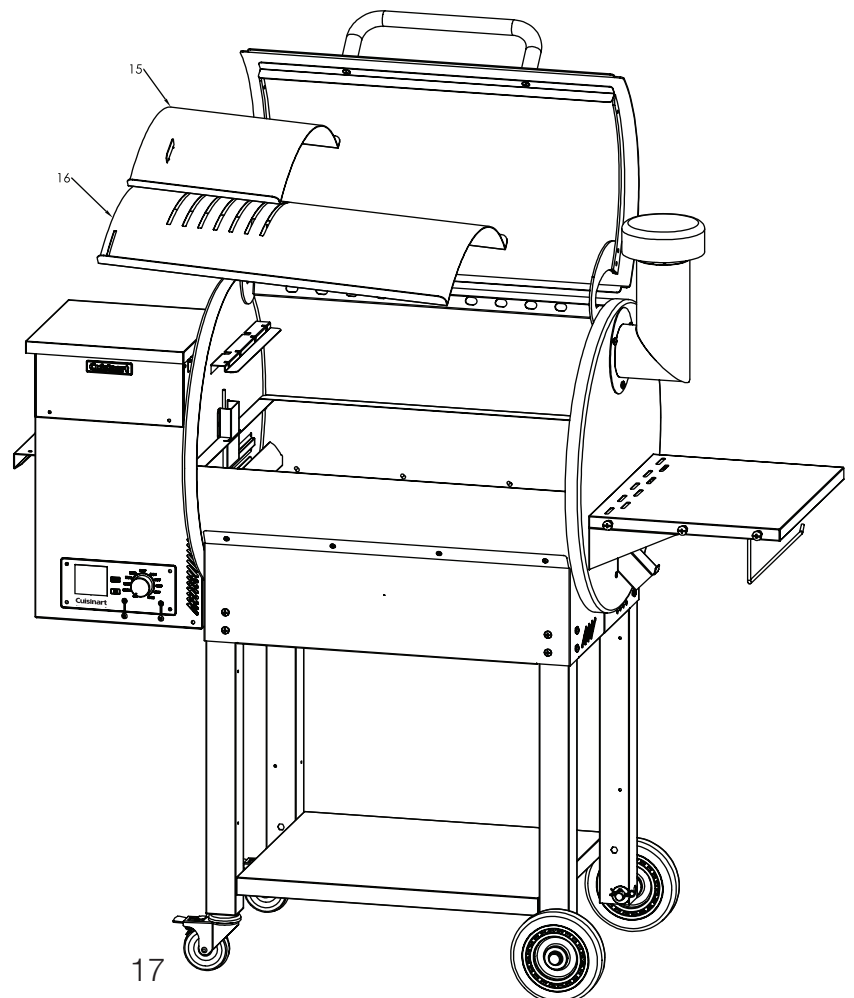

ASSEMBLY INSTRUCTIONS

STEP 21 - COOKING GRATES

- Place the Cooking Grates (13) into the grill chamber as shown.

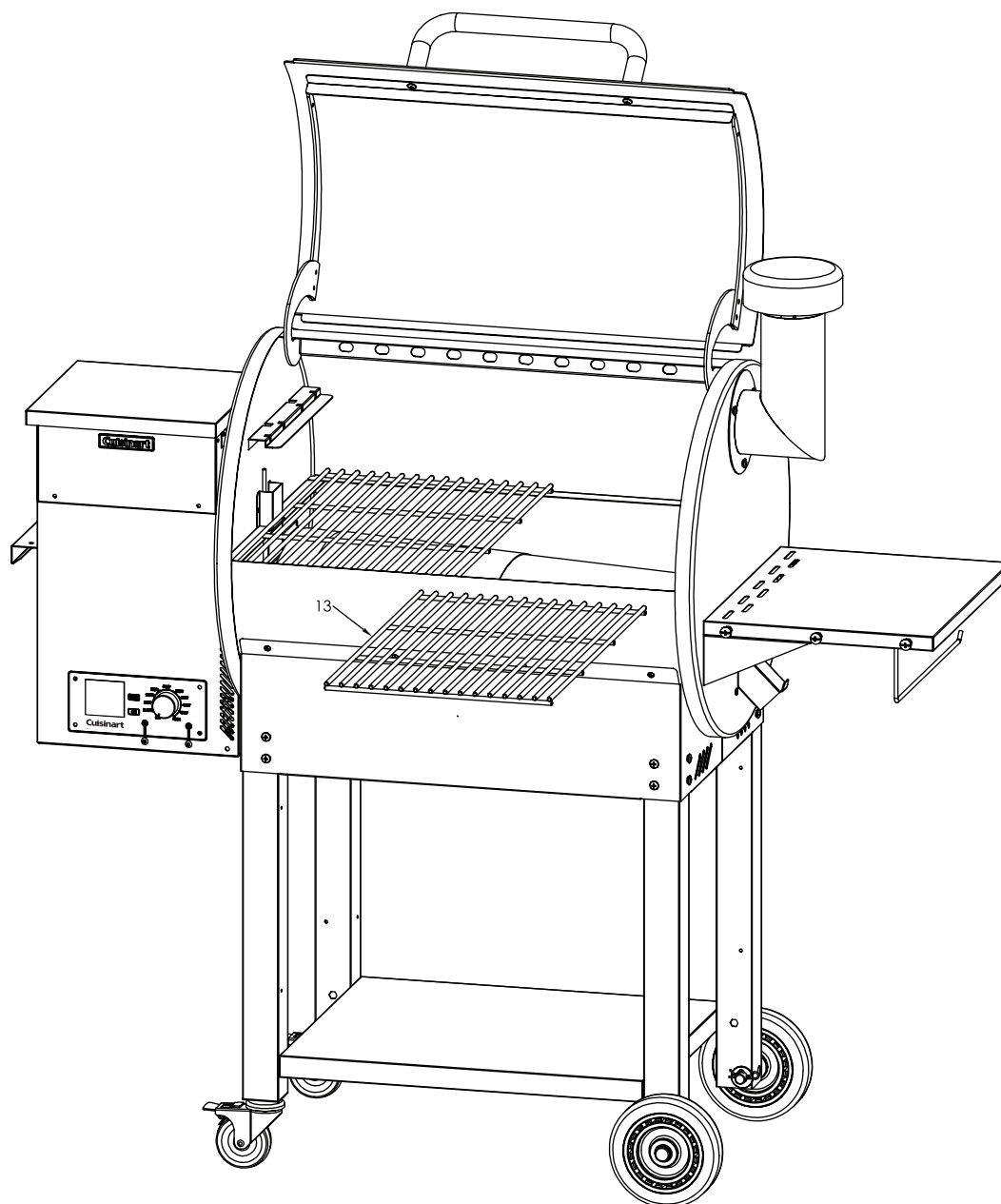

ASSEMBLY INSTRUCTIONS

STEP 22 - COOKING GRATES

- Place the Upper Cooking Rack (12) on the upper ledge inside the grill chamber, it will have slots to lock the rack in place.

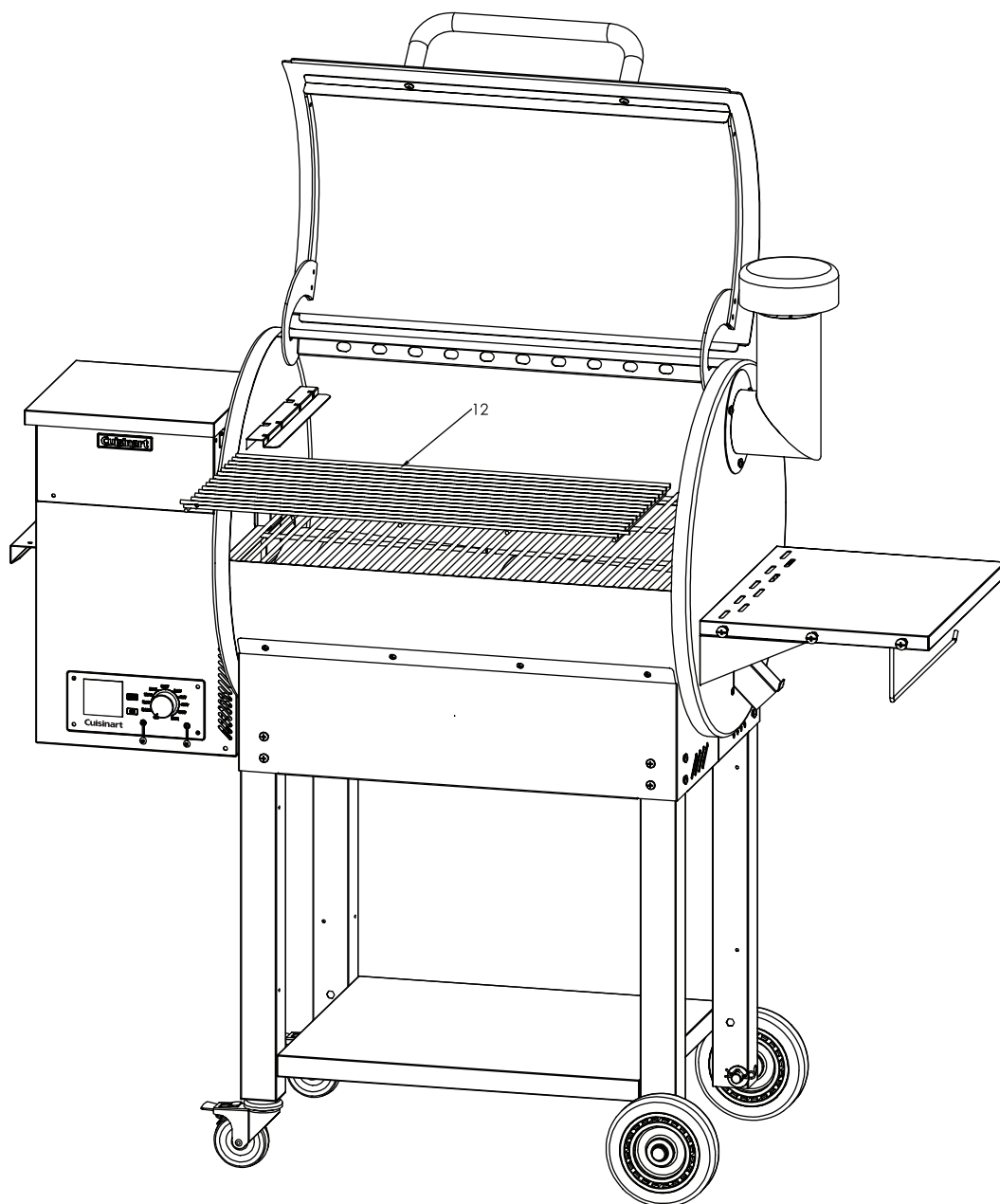

ASSEMBLY INSTRUCTIONS

STEP 23 - GREASE BUCKET

- Hook the Grease Bucket (35) onto the Grease Channel.

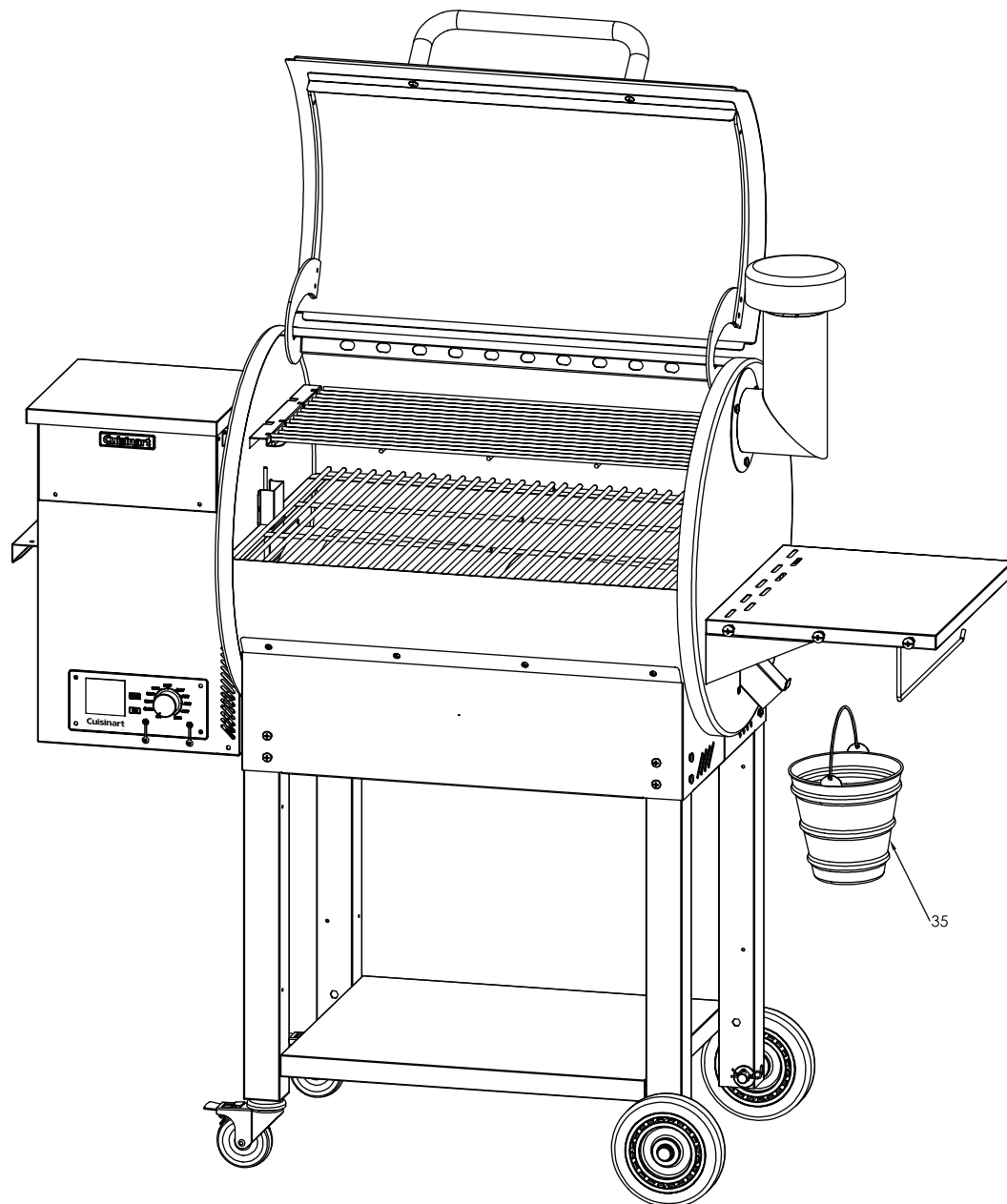



WARNING

Read and follow all warnings and instructions contained in the preceding sections of this manual.

Control Panel

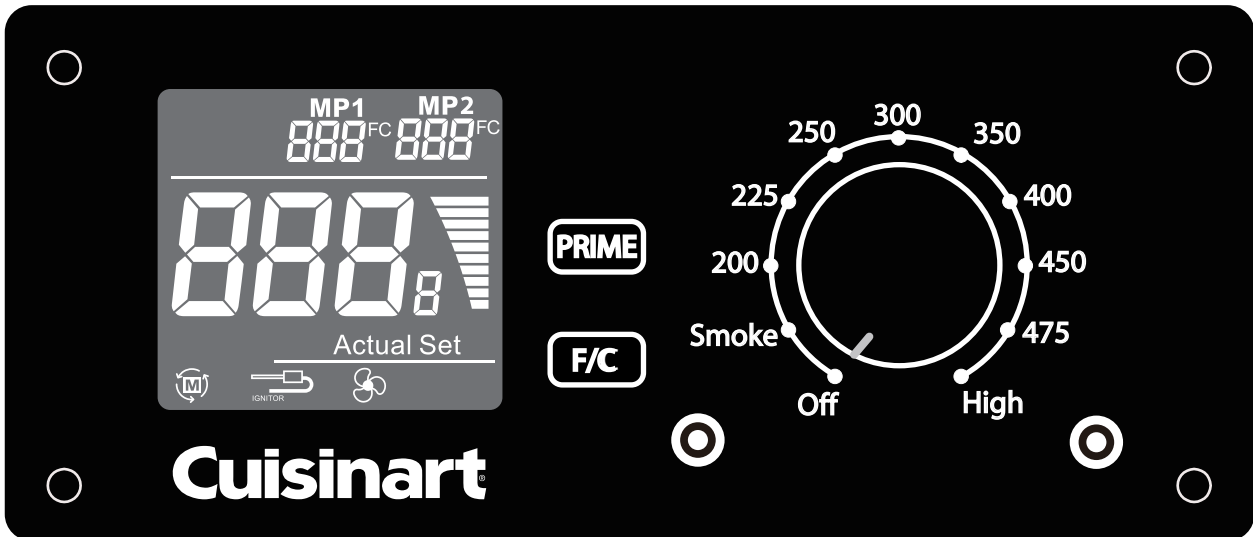

- **Control Panel:** The LCD Screen is used as the information center for your unit. The LCD screen will display the current grill temperature (ACTUAL) and meat probe temperature (MP1). See Troubleshooting for more information on error codes.
- **Flashing Screen:** Indicates the unit was just connected to AC power. Screen flashes three times, then turns off.
- **MP1 MP2:** Indicates the meat probe temperature when probe is connected.
- **Actual:** Indicates the current temperature of unit.
- **Set:** Indicates the desired temperature that has been selected.
- **noP:** Indicated that no meat probe is connected.
- **Motor:** Indicates the auger motor is turning and feeding pellets to the fire pot.
- **Ignitor:** Indicates the igniter is on. When first starting your unit, the igniter runs continuously for the start-up cycle.
- **Fan:** Indicates the fan is running. If the grill is in operation, the fan is on.
- **Prime:** Press and hold the Prime Button to activate an extra feed of pellets to the fire pot. This can be used to add more fuel to the fire just before opening the barrel lid, resulting in a quicker heat recover time. It can also be used to add more fuel while smoking, to increase the intensity of clean smoke flavor. Overfeeding the fire pot may cause damage to the grill barrel paint.
- **F/C:** The Temperature Switch Button is used to change the temperature readout on the LED Screen. Press the button to switch to Fahrenheit (°F) or to Celsius (°C), as preferred. Default is set to Fahrenheit.
- **Temperature Control Dial:** Allow you to set your desired temperature. Rotate the knob marker to select from Smoke, any of the eight temperature presets, or High. Once rotating the dial, the SET Temperature on the LCD Screen will adjust.
 - **OFF:** The Off Setting on the Temperature Control Dial is the OFF mode for the unit. The unit will not function on this setting.
 - **SMOKE:** The Smoke Setting on the Temperature Control Dial is the lowest smoking mode for the unit. The grill operates at the lowest temperature, without the fire going out.
 - **HIGH:** The High Setting on the Temperature control Dial is the highest heat level for the unit. The grill operates at the highest temperature. When the lid is open, the grill will run at this speed to compensate for the loss of heat in the barrel.
- **Plug-In Connection Port:** The plug-in connection port on the front of the control board is for the meat probe. When the meat probe is connected, the temperature is displayed on the LCD Screen. When the meat probe is not in use, disconnect the adapter from the connection port.

WARNING

- **DO NOT leave your grill unattended while in use.**
- **DO NOT move grill when in use. Lock wheels in place to stabilize grill.**
- **DO NOT use water to extinguish flare-ups.**
- **Ensure grill is on a stable, level surface and all four casters are in firm contact with the ground.**

TURNING ON THE GRILL:

Note: It is recommended to wash the grill grates and smoking racks with warm soapy water before initial lighting of the grill.

INITIAL LIGHTING INSTRUCTIONS:

- **To be used on initial firing or anytime the grill runs out of pellets.**
- **Always allow the auger tube to fully load with pellets to ensure proper lighting of the grill.**

Step 1: Open lid and remove cooking grates, sear shutter, and drip shield from inside the grill. Leave lid open.

Step 2: Plug power cord into a GFI (grounded) outdoor electrical outlet. Use only a Ground Fault Interrupter (GFI) protected circuit with this outdoor cooking appliance. Never remove the grounding plug or use with an adapter with 2 prongs. Only use extension cords with a 3 prong grounding plug, rated for the power of the equipment, and approved for outdoor use with a W-A marking.

Step 3: Open the pellet hopper lid. Make sure the auger is free from debris and other objects. Turn the temperature control knob to 200° F.

- Look inside the pellet hopper to verify the auger is slowly turning.
- Place your hand about 3" above the fire pot and make sure you can feel air blowing out from the fire pot.
- After a few minutes the air should be slightly warmer, this indicates the igniter is getting hot. Even when functioning properly, the igniter does not glow. **DO NOT TOUCH THE IGNITOR!**
- Verify the digital display is not displaying any error codes. Note: Please see the troubleshooting section for error code details.
- If all the above checks pass, press the power button to turn off the grill. The internal fan will stay on for 10 minutes after the grill is turned off. This is normal.
- If any of the above checks fail, consult our Troubleshooting section.

Step 4: Fill the pellet hopper with cooking pellets.

 **WARNING: Never use heating fuel pellets as they are not safe for cooking.**

Step 5: Turn the grill back on.

NOTE: During the initial loading of the auger tube, it will take several minutes for the pellets to move from the pellet hopper to the fire pot. You can speed this process up by holding the Prime button.

Step 6: When the pellets start falling into the fire pot, turn off the grill.

Step 7: Replace the drip shield, sear shutter, and cooking grates in the cooking chamber.

Step 8: Keeping the lid open, turn the control knob to a desired temperature. After a few minutes you should smell and see smoke. Initial start up will always be very smoky but it will reduce when the fire is fully lit.

NOTE: The igniter turns off after 10 minutes to preserve the life of the component and to save electricity

Step 9: After the fire has started close the lid to allow the chamber to pre heat. If this is your first time starting this grill refer to the next section "BREAKING IN YOUR GRILL."

BREAKING IN YOUR GRILL:

Many surfaces of your Pellet Grill have been coated in a thin layer of oil to protect it during shipping. After you have started a fire in the fire pot and before cooking food for the first time allow the grill to run at the highest temperature setting for 30 minutes with the lid closed to ensure it is properly seasoned. Then turn the control knob to off and allow the grill to go through its shut down cycle. The fan will continue to run for a time before powering off, this is an essential safety step to blow out the fire.

SUBSEQUENT LIGHTING INSTRUCTIONS:

Step 1: Empty the contents of the fire pot. For best results, use an ash vacuum. When done replace all internal components including the cooking grates.

Step 2: Open pellet hopper lid and check the pellet level. Add more pellets if necessary.

⚠ WARNING: NEVER add cooking pellets to a hot fire pot by hand. You could be seriously burned. If the hopper runs out of pellets or your fire goes out while cooking, let the grill completely cool and follow the Initial Lighting Instructions.

Step 3: Open the lid and plug the grill into a GFI outlet. Turn the control knob to the desired temperature and wait for the fire to start, this should take about 10 minutes.

Step 4: After the fire is started in the fire pot close the lid. For best results, preheat the grill for 15 to 20 minutes with the doors closed before placing food in the grill.

GRILL DOES NOT LIGHT OR FIRE IN POT EXTINGUISHES WHILE COOKING:

Step 1: Turn off the grill and wait for it to complete its shut down processes, then unplug. Open cooking chamber doors and remove all food, cooking grates, sear shutter, and drip shield.

⚠ WARNING: Always use oven mitts/gloves to protect your hands. Metal parts become hot during use. Use extreme caution when handling cooking grates, grease tray and baffle.

Step 2: Clean ash and pellets from the Fire Pot. Using an ash vacuum will make this easier.

Step 3: Restart the grill and check the fan, ignitor, and auger to ensure they are operational. You should feel wind just above the fire pot, the igniter will warm the air above the fire pot after a few minutes and pellets should be falling into the fire pot from the auger tube. If any of these things do not happen please refer to our troubleshooting section.

Step 4: Wearing oven mitts/gloves, replace all the components removed in Step 1.

Step 5: Preheat the grill for 10 to 15 minutes with lid closed before placing food back in the grill. If this procedure is not successful, see Troubleshooting section in your owner's manual.

OPERATING THE GRILL

MANUAL START-UP PROCEDURE: (To be used if ignitor is not working properly):

Step 1: Ensure the grill is off. Plug the power cord into a grounded power source.

Step 2: Check fire pot to ensure there is no obstruction for proper ignition. Fill pellet hopper with cooking grade pellets.

Step 3: Open the lid and remove all internal components to get a view of the fire pot. Turn the control knob to the desired temperature and wait until pellets begin falling into the fire pot.

Step 4: Place a small handful of pellets into the fire pot. Squirt a gelled fire starter, or other appropriate pellet starter, over the top of the pellets. A small amount of solid fuel fire starter, such as those composed of sawdust and wax, or wood shavings, is also recommended. Add another small handful of pellets in the fire pot.

NOTE: Do not use gasoline, lighter fluid, kerosene, or petrol for lighting a fire in your grill.

Step 5: Light the contents of the fire pot using a long match or a long lighter. Allow the starter to burn 3 to 5 minutes. Do not attempt to add more starter into the fire pot as this can cause injury.

Step 6: Quickly and carefully replace all components removed in Step 3. Continue on from Step 2 of the "Subsequent Lighting Instructions".

TURNING OFF THE GRILL:

Step 1: Turn the temperature dial to "OFF". An auto cool down feature will keep the fan running for 10 minutes. If you don't allow the grill to run the cool down feature a fire may travel up the auger tube and ignite your pellet hopper.

Step 2: After the auto cool down is complete the fan should power off automatically, you may now unplug the power cord from the GFI outlet.

⚠ WARNING: Do not unplug the grill while the fan is still working on the shut down cycle, the grill will automatically shut off when the cycle is done. Interruption of the shut down cycle could result in a fire in the hopper chamber.

OPERATING TIPS:

- **⚠ NEVER move your Pellet Grill while it is hot. If you are transporting your grill in a vehicle after cooking on it, make sure the fire is completely out and the grill is cold before placing it in any vehicle.**
- NEVER put water into the fire pot. It will jam the auger and can damage the ignitor.
- The Pellet Grill is designed to operate with the lid closed.
- The temperature readout is an approximate and can be affected by the following factors: outside ambient temperature, the amount and direction of wind, the quality of pellet fuel being used, the lid being opened, and the quantity of food.
- When selecting a temperature setting, the auger will feed pellets for several minutes. This will momentarily raise the temperature, but the temperature will decrease and stabilize after 10-15 minutes.
- The auger will not run 100% of the time, it cycles on and off depending on the temperature setting.
- Pellets can hang up in the pellet hopper after cooking for a long period of time. It's important to monitor the pellet level and mix the pellets by hand to ensure they flow into the auger.

PREHEATING THE GRILL:

Prior to use, it is recommended that you preheat your grill. This ensures that the cooking grates are at the desired temperatures to sear the food sugars when cooking. Preheat the grill for 15 to 20 minutes or until it reaches the desired temperature before adding food. Close the lid during the preheat period.

SMOKING:

To smoke food on your Cuisinart Pellet Grill:

Step 1: Set the grill to “SMOKE” or a low temperature like 225° F. Higher temperatures will produce less smoke so try to keep it below 300° F.

Step 2: Allow the grill to preheat and ensure sear shutter is closed.

Step 3: When the grill temperature has stabilized, about 20 minutes, place the food to be smoked on one of the two smoking racks.

Step 4: Use a food probe to monitor the internal temperatures of your food to ensure doneness.

- **Tip: Cold food absorbs smoke more easily than food at room temperature.**

SEARING:

The Cuisinart Pellet Grill is equipped with a direct sear function which allows you open an air path between your food and the fire pot.

To operate:

Step 1: Set the grill temperature to “HIGH” and slide the sear shutter to the right using tongs.

Step 2: Allow the cooking grates to preheat before placing food on them to maximize grill marks.

FOOD PROBES:

There are two food thermometers supplied with your Cuisinart Pellet Grill.

To use:

Step 1: Insert the food probe plug into appropriate port on the Control Board.

Step 2: The long sharp thermometer probe should be fully inserted into the thickest part of your food, ensure the tip of the thermometer does not come out the other side. Be careful to avoid bones when inserting the probe because if left near a bone, the temperature readings may become inaccurate. The temperature will be displayed on the control board.

NOTE: When placing the meat probe into your meat, ensure the meat probe and meat probe wires avoid direct contact with flame or excess heat. This can result in damage to your meat probe. Run the excess wire out the hole located on the left side of the main grill or the top of the main grill (near the grill lid hinge). When not in use, disconnect from the meat probe connection port and place aside to keep protected and clean.

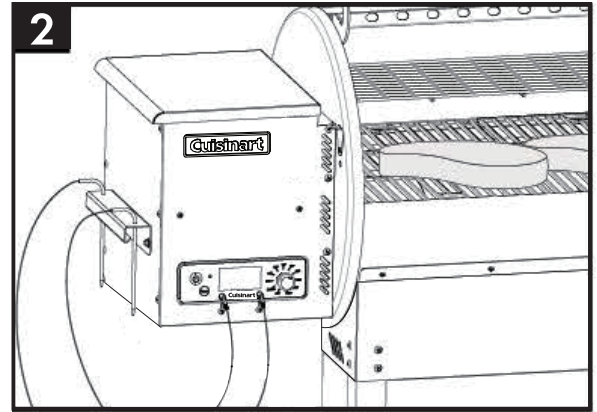
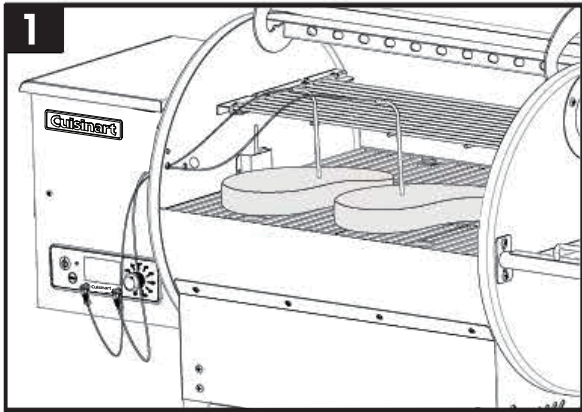

GRILLING TO PROPER TEMPERATURE:

- Use a meat thermometer to be sure food has reached a safe internal temperature.
- The US Department of Agriculture recommends the minimum temperature be reached for the following food items:

Ground Meat	160° F (71° C)
Pork	145° F (62.8° C)
Poultry	165° F (73.9° C)
Roasts	145° F (62.8° C)
Seafood	145° F (62.8° C)
Vegetables	145° F (62.8° C)

- Use caution when removing food from Pellet Grill. All surfaces are HOT and may cause burns. Use protective gloves or long, sturdy cooking tools to remove food.
- This grill is HOT while in use and will remain HOT for a period of time afterwards. Use caution.
- Pellet grills do not produce highly visible smoke 100% of the time. Even though you don't see smoke you are still getting smoke flavor.

COOKING TIPS:

CLEANLINESS:

- Always wash hands thoroughly with soap and hot water prior to handling food and after handling raw meat, uncooked poultry or seafood.
- When using a platter to carry raw meat, uncooked poultry or seafood to the grill, make sure to wash the platter thoroughly with soap and hot water before placing cooked foods back on the platter or use different platters for raw and cooked foods.
- Never use the same utensils when handling raw meat, uncooked poultry or seafood unless you wash the utensils thoroughly with soap and hot water.
- Never re-use marinade from raw meat or uncooked poultry on foods that have been cooked and are ready to be served.

HELPFUL HINTS:

- If you pre-cook meat or poultry, do so immediately before grilling.
- Never defrost meat at room temperature or on a counter top. When defrosting meat at room temperature or on a countertop be aware of the “Danger Zone” which is the temperature range between 40° F and 140° F. Bacteria is most active at these temperatures and can double in population in as little as 20 minutes.
- Refrigerate leftovers within 2 hours of taking food off the grill.
- For additional information, please phone the USDA’s toll free Meat & Poultry Hotline at 800-535-4555.

INSIDE SURFACES:

It is recommended to regularly clean out any ash and pellet debris from the fire pot by scooping it out or using a shop-vac.

Perform the above maintenance every time you add pellets to the hopper.

Use a long-handled grill cleaning brush (brass or soft metal), remove any food or build-up from the cooking grates. Best practice is to do this while they are still warm from a previous cook. Grease fires are caused by too much fallen debris on the cooking components on the grill. Clean the inside of your grill on a consistent basis. In the event you experience a grease fire, keep the grill lid closed to choke out the fire. If the fire does not go out quickly, carefully remove the food, turn off the grill, and shut the lid until the fire is completely out. Lightly sprinkle baking soda if available.

IMPORTANT: Due to high heat, do not cover the flame broiler or probes with aluminum foil.

GREASE BUCKET:

Check your grease bucket often and clean out as necessary. For easy clean, line the bucket with foil, then toss when full.

PELLET HOPPER CLEAN-OUT:

If grill will be left un-attended for a long period of time, we recommend you remove unused pellets. Always store wood pellets away from heat and in a dry location.

Step 1: Place a clean, empty pail under the drop chute (located under the hopper).

Step 2: To empty, locate the plate on the back side of the hopper. Unscrew the plate, slide outwards, and pellets will empty.

Step 3: Use a long handled brush or shop-vac to remove excess pellets and debris for a complete clean-out through the hopper screen. Once clean, slide plate back into place and tighten screw.

NOTE: Running all pellets out of your auger system is recommended if your grill will be unused for an extended period of time. This can be done by simply running your grill on an empty hopper until all the pellets have emptied from the auger tube.

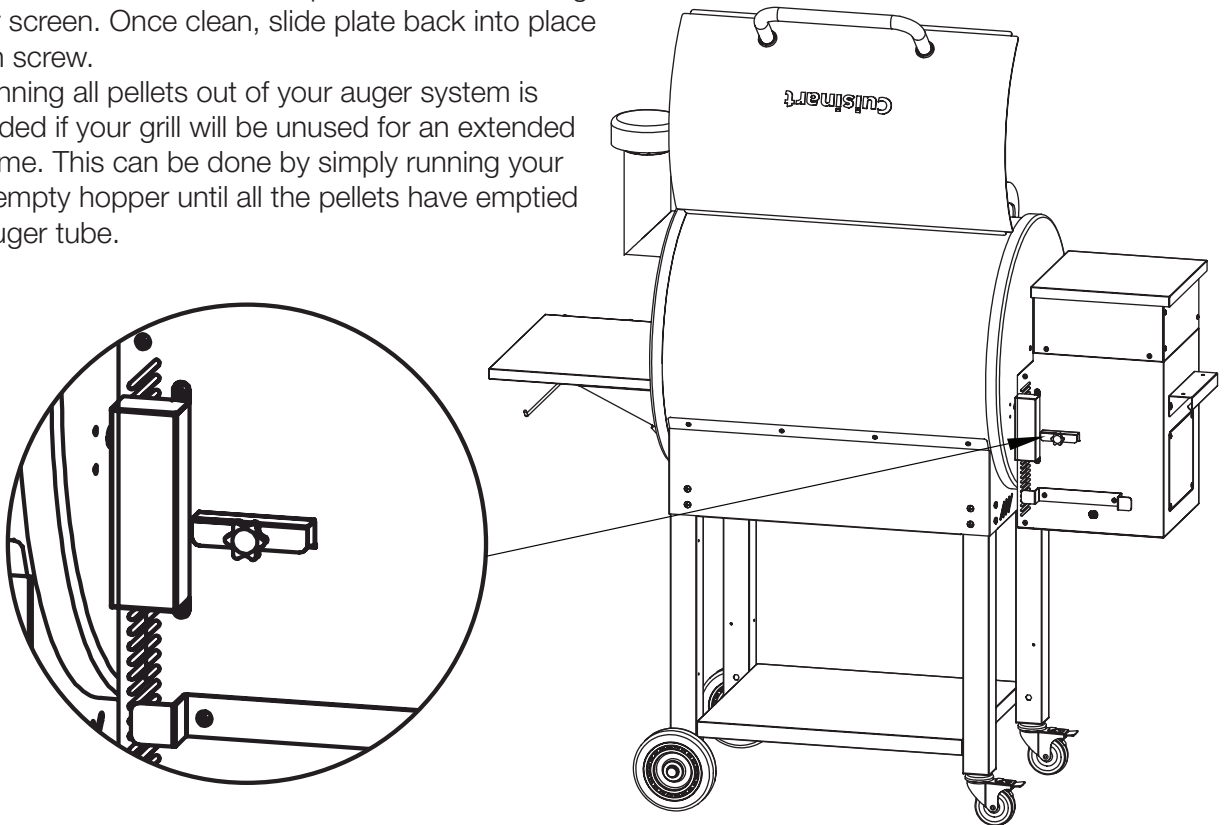

PROPER CARE & MAINTENANCE:

- Remove wood pellets from hopper if grill will not be used for a long period of time. Wood pellets can become soggy due to moisture/humidity and can cause the auger to bind up or not push pellets to burn chamber.
- Disposal of ashes – Ashes should be placed in a metal container with a tight-fitting lid. The closed container of ashes should be placed on a non-combustible floor or on the ground, well away from all combustible materials, pending final disposal. When the ashes are disposed by burial in soil or otherwise locally dispersed, they should be retained in the closed container until all cinders have thoroughly cooled.
- It's important to keep your grill always covered when not in use to avoid rain getting inside the grill and damaging the grill and/or cause excessive corrosion. The grill and pellets must be kept dry in order to function properly.
- Wash cooking grates and drip shield with hot, soapy water, rinse well and dry. Lightly coat grill grates, sear shutter, and drip shield with a high smoke point food grade oil like vegetable oil or canola oil. Never use a commercial oven cleaner because it may damage the painted finish.

CARE AND MAINTENANCE

- Clean inside and outside of grill by wiping off with a damp cloth. Apply a light coat of vegetable oil or vegetable oil spray to the interior surface to prevent rusting.
- Never apply paint to the interior surface. Rust spots on the interior surface can be buffed, cleaned, then lightly coated with vegetable oil or vegetable oil spray to minimize further rusting.
- Depending on use, periodically remove the cooking grates, and drip shield to clean the ash from in and around the fire pot.
- Keep the appliance free and clear of combustible materials, gasoline and other flammable vapors and liquids.
- For safe grilling and peak performance of your grill, perform these checks at least twice per year or after extended periods of storage.
- Be sure to tighten up all hardware (nuts, bolts, screws, etc.) at least twice per year.

 **CAUTION: Some parts may contain sharp edges. Wear protective gloves if necessary.**

TRANSPORTING AND STORAGE:

Warning

- **Never move a grill when it is hot or when objects are on the cooking surfaces.**
- **Never store flammable liquids or spray canisters under or near the grill.**
- **DO NOT extinguish grease fires using water.**

BEFORE STORING YOUR GRILL:

- Clean all surfaces.
- If storing the grill outdoors, close the wood pellet lid and cover the grill with a cover for protection from the weather.
- If the grill is stored outside during the rainy season, care should be taken to ensure that water does not get into the pellet hopper. Wood pellets, when wet, expand greatly and will jam your auger.
- Never move a grill when it is hot or when objects are on the cooking surfaces.
- Never store flammable liquids or spray canisters under or near the grill.
- Unplug the grill before storage.
- For long term storage remove all pellets from inside the grill, including emptying the auger.

 **DO NOT extinguish grease fires using water.**

ISSUE RESOLUTION:

PROBLEM	POSSIBLE CAUSE	SOLUTION
LCD screen will not light up	There is no power	Make sure the grill is plugged into a functional GFI certified outlet. Ensure the GFI outlet has not tripped. Test the outlet with another appliance that is known to work
	The fuse is blown.	Remove the control panel by unscrewing the four screws from the outside. There is a green fuse holder on the back of the control panel assembly.
	Connections to the control panel are loose	With the grill unplugged access the back of the control panel and ensure all connectors are securely attached and in the proper locations. Refer to the wiring diagram.
Grill is not getting hot enough	Temperature adjustment too low	Turn up heat on the control knob.
	Opening the lid too often	Opening the lid allows heat to escape and causes the temperature to vary drastically from the set temperature.
	Out of pellets	Add pellets and allow sufficient time for the pellets to travel from the pellet hopper to the fire pot (can take up to 10 minutes). Restart the grill after adding new pellets.
Fire goes out unexpectedly	Excessive ash buildup	Clean out the fire pot.
	Poor pellet quality	Inspect pellets to ensure they are whole and are not damp. If they are, replace pellets and restart the grill.
Pellets will not light after several minutes	Auger is not primed	Before the unit is used for the first time or anytime the hopper is emptied, allow the auger tube to fully load with pellets to ensure proper lighting of the grill (about 9 minutes). Follow Initial Lighting Instructions.
	Auger is jammed	Remove all components inside the firebox and inspect the fire pot, are there fresh pellets inside? If not, inspect the auger to see if it is turning at all. If the auger is not turning and you are sure there are fresh pellets in the hopper, please contact our customer support team.
	Ignitor has failed	Remove all components from inside the fire box and inspect the fire pot. If there are fresh pellets but they are not lighting the ignitor is malfunctioning. Contact our customer service team for a resolution. If a replacement part is required, follow Manual Start-Up Procedure to continue using the grill as you wait for it to arrive.
Grill is getting too hot	Adjust temperature control	Reduce heat by reducing the selected temperature setting.
	Pellet overflow in fire pot	After everything is cool, clean out the fire pot.
Temperature fluctuations	External Factors	Temperature fluctuations are normal for pellet grills. Any significant fluctuations can be caused by wind, air temperature, improper use, or lack of grill maintenance.

TROUBLE SHOOTING

PROBLEM	POSSIBLE CAUSE	SOLUTION
Smoke comes out of pellet hopper	This is normal due to the air pressure inside the grill. The amount of smoke can vary depending on cooking conditions.	This condition will not affect cooking. But can be minimized by ensuring the inside of the grill is clean and there is not excessive ash.
	Unplugged grill too soon.	Once the grill is turned off the fan will continue to run for 10 minutes. If you do not allow the grill to go through the cool down process it can cause fire to transfer to the auger tube. Plug the grill back in and turn it on to activate the fan, then go through the proper shut down procedure.
Flare ups or grease fires	Excessive grease build up or temperature setting too high while cooking greasy food	If a grease fire occurs, keep the doors closed and hold the power button to go through standard shut down procedures. To avoid this condition ensure the interior of the grill is cleaned of grease regularly to prevent buildup and cook below 350° F for very greasy foods.
Prolonged excessive or discolored smoke	poor pellet quality	Pellets may be damp or have broken down into dust. Replace pellets with fresh ones.
	Ash build up in fire pot	Operating the ash clean out mechanism before every cook will prevent this from ever happening.
"ER1" Error Code	ER1-Internal thermometer of the grill is malfunctioning	Check to see if the temperature probe is attached to the control panel. If it is loose, firmly connect the probe to the control panel and restart the grill. If there is no problem with the connection then you may need to replace the temperature probe, please call our customer service team for assistance.
"ER2" Error Code	ER2-An error occurred during the startup cycle	<p>-Power the grill off and wait for it to cool. When ready remove all internal items and clean out the fire pot. Power the grill back on and set to any temperature.</p> <p>-Ignitor: is it getting hot? Hover your hand over the fire pot an inch or two to feel for heat.</p> <p>-Fan: hover your hand over the fire pot to feel if there is any air movement. You should also be able to very clearly hear the fan if it is operational.</p> <p>-Auger motor: Visually inspect the auger for a minute to see if pellets are coming out. If yes, are the pellets in good shape? If any of the components are not operating properly please call our customer service team for a resolution.</p>
"ER3" Error Code	ER3- The fire has gone out	Follow the same procedure as ER2.
"ERH" Error Code	ERH-High temperature alert	The internal temperature has reached over 650° F, which is above the normal operating temperature of this grill.

EXPLODED VIEWS

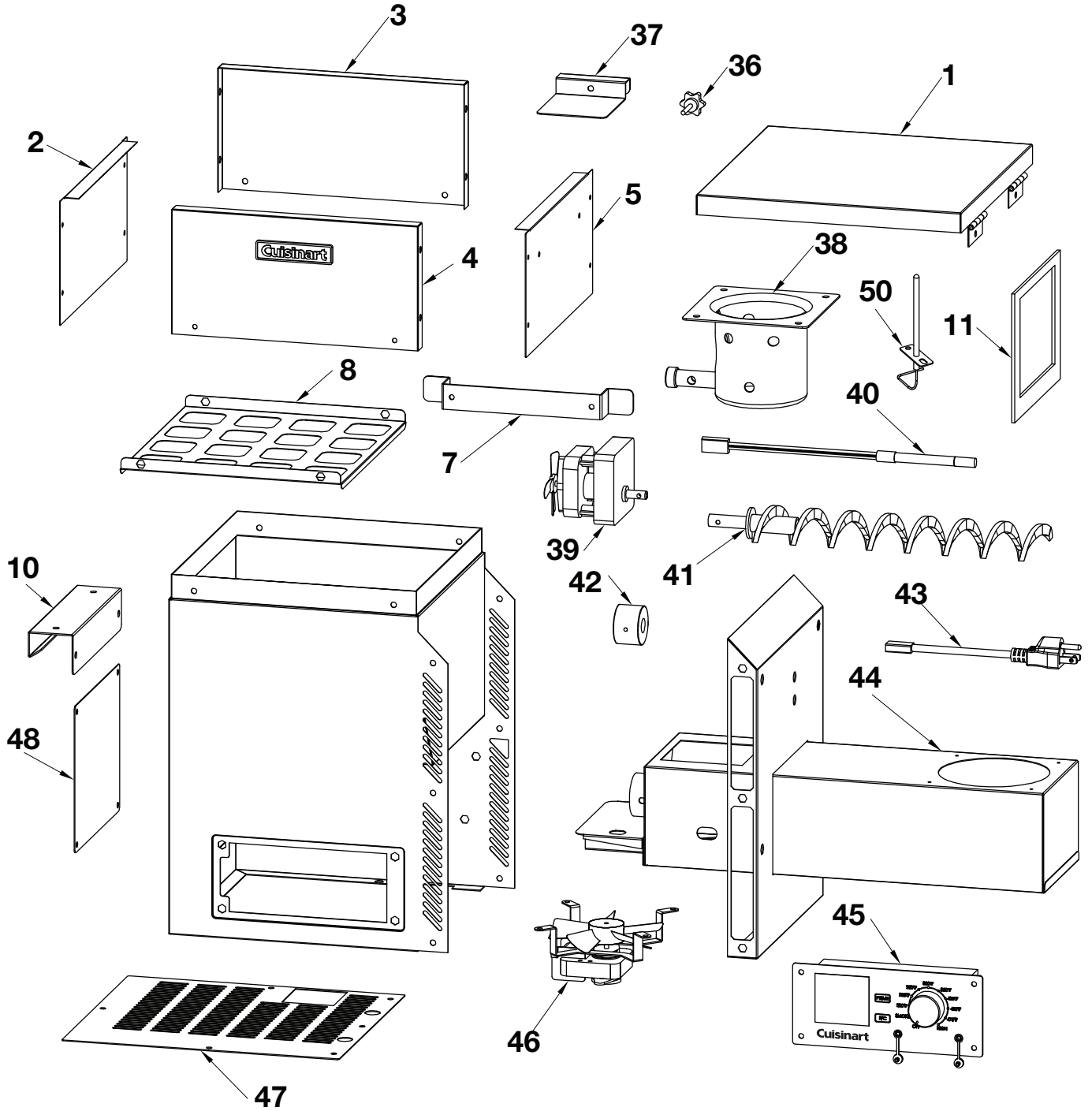

EXPLODED VIEWS

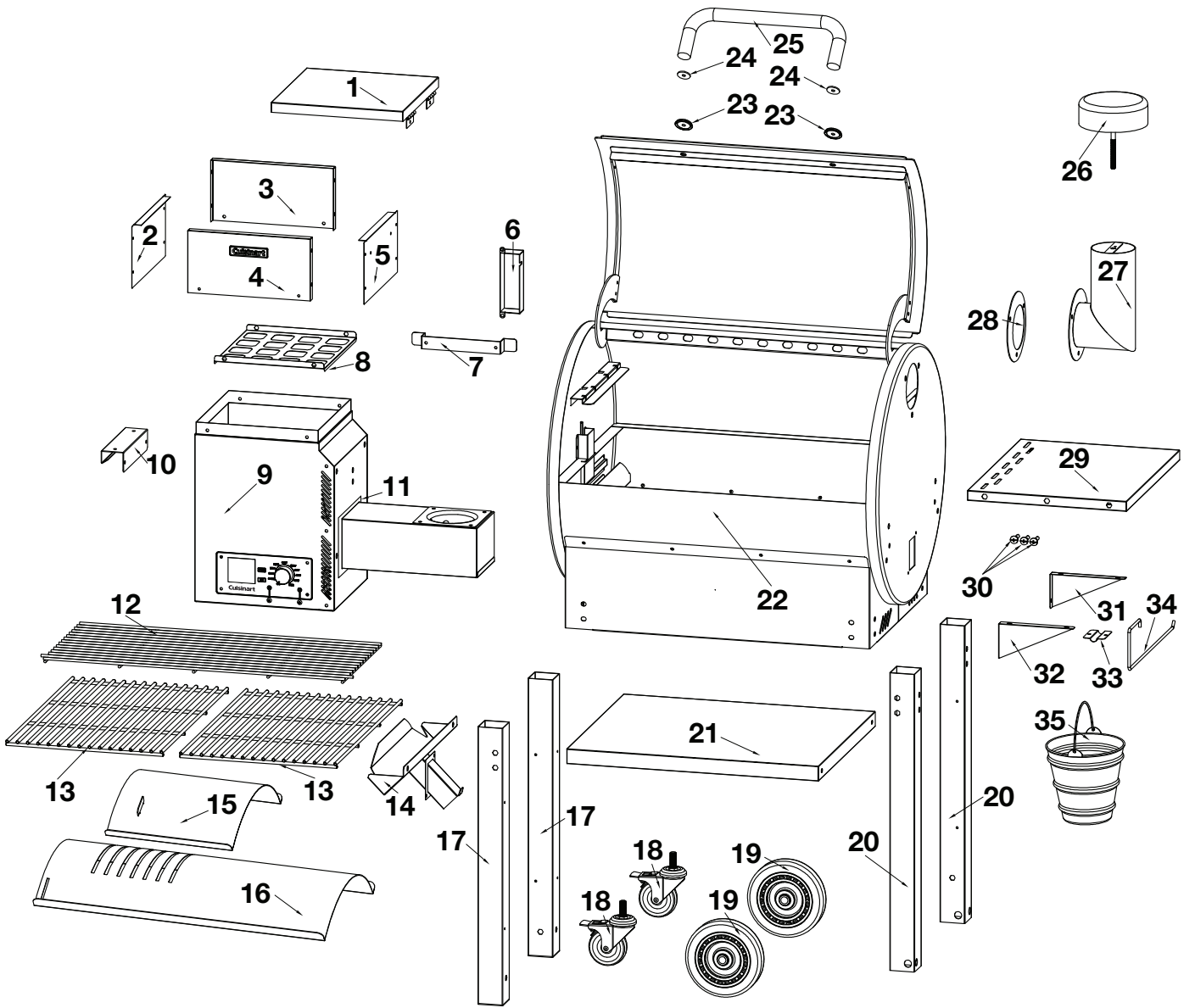

WARRANTY AND REPLACEMENT PARTS

PARTS LIST:

	Description	Qty	No.	Description	Qty
1	Hopper Lid	1	26	Chimney Cap	1
2	Hopper top left panel	1	27	Chimney	1
3	Hopper top back panel	1	28	Chimney Gasket	1
4	Hopper top front panel	1	29	Side Shelf	1
5	Hopper top right panel	1	30	Tool Hooks	3
6	Temperature Probe Cover	1	31	Side Shelf Bracket (right)	1
7	Cord Wrap	1	32	Side Shelf Bracket (left)	1
8	Hopper Grate	1	33	Paper Towel Bracket	1
9	Hopper Body	1	34	Paper Towel Rod	1
10	Handle	1	35	Grease Bucket	1
11	Hopper Gasket	1	36	Pellet Release Screw	1
12	Upper Cooking Rack	1	37	Pellet Release	1
13	Cooking Grid	2	38	Fire Pot	1
14	Grease Channel	1	39	Auger Motor	1
15	Sear Shutter	1	40	Hot Rod (Ignitor)	1
16	Drip Shield	1	41	Auger	1
17	Legs, Hopper Side	2	42	Auger Bushing	1
18	Locking Casters	2	43	Power Cord	1
19	Wheel	2	44	Fire Pot Assembly	1
20	Legs, Shelf Side	2	45	Control Panel	1
21	Bottom Shelf	1	46	Fan	1
22	Main Body	1	47	Hopper Bottom Panel	
23	Lid Handle Bezel	2	48	Service Panel	1
24	Insulation Washer	2			
25	Lid Handle	1			

	Hardware Parts	Qty
A	Phillips Head Screw 1/4" x 5/8"	4
B	Flat Washer 1/4"	4
C	Lock Washer 1/4"	4
D	Wheel Pin	4
E	Cotter Pin	4
F	Wheel Washer	4
G	Phillips Head Screw 5/32" x 1/2"	4
H	Lock Nut 5/32"	4
I	Phillips Head Screw 1/4" x 3/4"	4

WARRANTY AND REPLACEMENT PARTS

WARRANTY

- PROOF OF PURCHASE is required to access this warranty program, which is in effect from the date of purchase.
- Customers will be subject to parts, shipping, and handling fees if unable to provide proof of the purchase or after the warranty has expired.
- If you have any questions or problems, you can call our customer service department at 1-866-994-6390 from 9:00am to 5:00pm Eastern time, Monday through Friday for assistance.
- This limited warranty applies to the functionality of the product ONLY and does not cover cosmetic issues such as scratches, dents, corrosion or discoloring by heat, abrasive and chemical cleaners or any tools used in the assembly or installation of the appliance, surface rust, or the discoloration of stainless steel surfaces. Paint is not warranted and will require touch up. RUST is not considered a manufacturing or materials defect.
- This limited warranty will not reimburse you for the cost of any inconvenience, food, personal injury or property damage.

LIMITED WARRANTY

- All parts warranted 3-years from date of purchase.

WARRANTY PROVISIONS

- This warranty is non-transferable and does not cover failures due to misuse of improper installation or maintenance.
- This warranty is for replacement of defective parts only. We are not responsible for incidental or consequential damages or labor costs.
- This warranty does not cover corrosion or discoloration after the grill is used, or lack of maintenance, hostile environments, accidents, alterations, abuse or neglect.
- This warranty does not cover damage caused by heat, abrasive and chemical cleaners, or any damage to other components used in the installation or operation of the gas grill.
- Paint is not warranted and may require touch-up. Items considered to be consumable such as batteries are not covered under this warranty.

DISCLAIMER OF IMPLIED WARRANTIES; LIMITATION OF REMEDIES

- Repair or replacement of defective parts is your exclusive remedy under the terms of this limited warranty.
- Manufacturer will not be responsible for any consequential or incidental damages caused by weather. This limited warranty or any applicable implied warranty does not cover damage resulting from acts of God, improper care and maintenance, grease fire, accident, alteration, replacement of parts by anyone other than manufacturer, misuse, transportation, commercial use, hostile environments (inclement weather, act of nature, animal tampering), improper installation not in accordance with local codes or printed manufacturer instructions.
- To register your Cuisinart product, please visit <https://cuisinart.registria.com>.
- For questions and replacement parts, please contact us at consumercare@thefulhamgroup.com or call 1-866-994-6390.
- Model # CPG-700
- North American Distributor: The Fulham Group Newton, MA 02466

