

# Instructions for LED Emergency Lighting Fixture

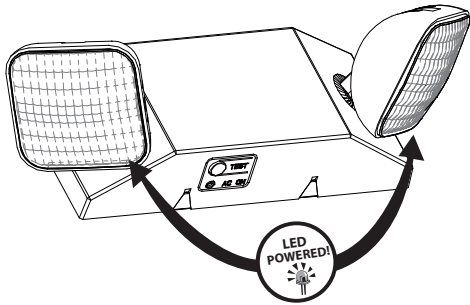

## IMPORTANT :

Let the battery charge up for at least 24 hours. Then normal operation of this unit should take effect. During an electrical power failure, the LED lamps will automatically come on for a minimum of 90 minutes. In accordance with NFPA 101, the emergency lighting system will go into a self-testing mode monthly for a minimum of 30 seconds and annually for 90 minutes. Refer to your local codes for any additional requirements that may apply.

## IMPORTANT SAFEGUARDS

When using electrical equipment, basic safety precautions should always be followed including the following:

## READ AND FOLLOW ALL SAFETY INSTRUCTIONS

1. Do not use outdoors.
2. Equipment should be mounted in locations and at heights where it will not be subject to tampering by unauthorized personnel.
3. Do not mount near gas or electric heaters.
4. The use of accessory equipment not recommended by the manufacturer may cause an unsafe condition.
5. Do not use this equipment for anything other than its intended use.
6. Servicing of this equipment should be performed by qualified personnel.
7. Disconnect AC power before servicing.

## SAVE THESE INSTRUCTIONS

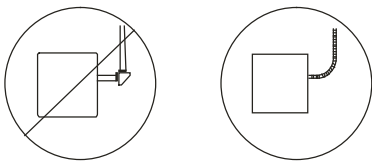

FLEXIBLE CONDUIT ONLY

## INSTALLATION (J-BOX MOUNTING)

1. Feed fixture leads through the back plate and connect to AC power supply (Fig A). For 120V use black and white wires and for 277V, use red and white wires.
2. Attach back plate to J-Box and secure with screws.
3. Complete the battery connection. (Fig. B)
4. Align snaps and push housing directly onto the back plate (Fig. C). Apply continuous AC power and test the unit.

## INSTALLATION (CONDUIT )

1. Secure back plate to wall surface. Route wires through hole in conduit flange and make conduit connection. For 120V, use black and white wires and for 277V, use red and white wires.
2. Complete the battery connection (Fig. B).
3. Align snaps and push housing directly onto the back plate (Fig. C). Apply continuous AC power and test the unit.

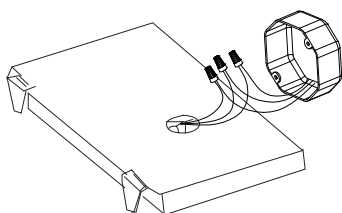

Fig.A (J-Box)

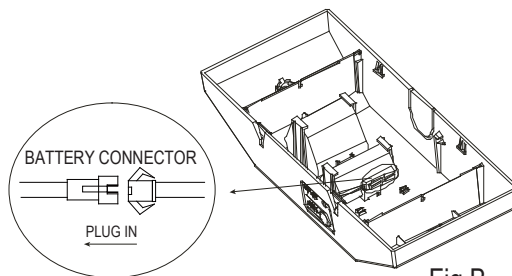

Fig.B

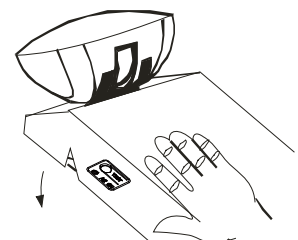

Fig.C

## WARNING:

Unused wires must be capped using enclosed wire nuts.

# WIRING DIAGRAM

## REMOTE CAPABLE

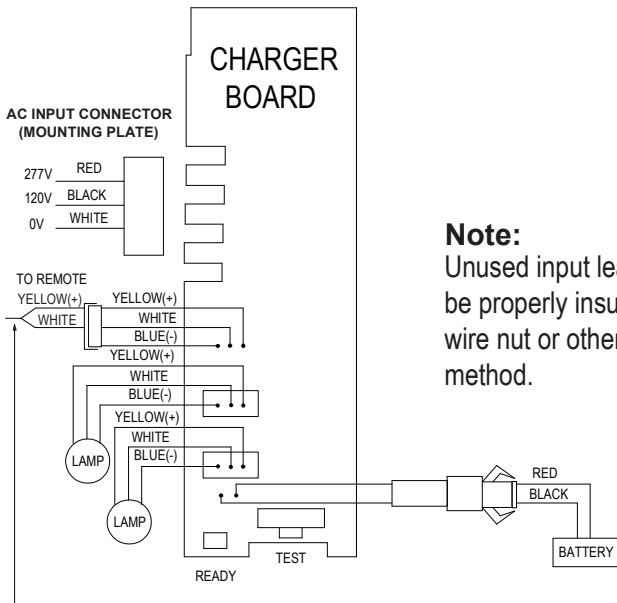

**Note:**  
Unused input lead must be properly insulated with wire nut or other approved method.

## REGULAR

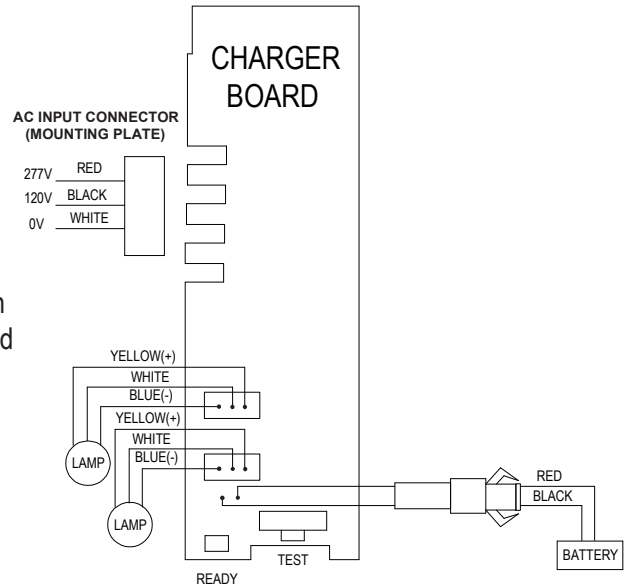

**Note:**  
To connect additional heads in remote, this jumper cable needs to be replaced by the remote head cable located in the accessory bag.

**Note:**  
Use 18-22 AWG stranded wire to connect remote lamp heads.

## INSTRUCTIONS FOR SELF-DIAGNOSTIC TEST:

Once the unit is properly installed according to the installation instruction sheet and AC power supplied, the dual color LED indicator will come ON and the self-diagnostic test function will automatically initiate. The LED indicates the unit's status. A STEADY GREEN LED indicates normal service; FLASHING GREEN indicates the unit is testing; GREEN/RED FLASHING indicates the battery is charging; RED (in different combinations) would indicate a service alert. Refer to the SERVICE INDICATION chart below for more details. The LED would be OFF when the unit is in emergency mode.

### SELF-DIAGNOSTIC SERVICE

The self-diagnostic function is factory preset and performs the following:

- a. Monitoring of battery, battery charger, and lamps (both local and remote lamps when applicable )
- b. Self-testing and a 30-second or longer discharge once every 30 days, after AC power has been supplied for a minimum of 24 hrs.
- c. Self-testing and a 30-minute or longer discharge once every 180 days, after AC power has been supplied for a minimum of 24 hrs.
- d. Self-testing and a 90-minute discharge once every 365 days, after AC power has been supplied for a minimum of 24 hrs.

### SERVICE INDICATION

LED Indicator	Status
One flash red	Replace electronics
Two flash red	Replace battery
Four flash red	Replace lamp head board
Five flash red	Replace Remote lamp head or Remote lamp head disconnected
Steady red	Battery disconnected
Solid green	Trickle charge
Flashing green	In test
Red/Green flashing	Hi charge

### MANUAL TESTING

The unit also provides for manual testing by pushing the test button in a specific pattern.

Action	Reaction & LED Indication
Push test button Once (within 2 seconds)	30-second test: FLASHING Green
Push test button Twice (within 2 seconds)	30-minute test: Green FLASHING twice
Push test button Three times (within 2 seconds)	90-minute test: Green FLASHING three times
Push test button and hold for 3 seconds (In test mode)	Cancels test. If self-test is cancelled it is recommended that a manual test of the same duration be performed at a more convenient time to ensure compliance
Push test button and hold for 6 seconds (In test mode)	System reset

### **WARNING:**

- a) Make sure that power is OFF before making any electrical connections.
- b) Unused wires must be capped using enclosed wire nuts.