



Manufactured by:
Backyard Discovery
3305 Airport Drive, Pittsburg, KS
66762 800-856-4445

Basepoint Business Centre: Rivermead Drive, Westlea, Swindon SN5 7EX Phone: 0800-118-2476
J.P. Coenstraat 7, The Bridge, The Hague, 2595 WP, Netherlands Phone: 08005678990

ANIMAL ENCLOSURE XL

MODEL # : 2600041



Please visit www.backyarddiscovery.com
For the most up to date assembly manual, to register your product, or to order
replacement parts *Para obtener instrucciones en español, visite*
www.backyarddiscovery.com



EASY STEP-BY-STEP
3D INTERACTIVE INSTRUCTIONS
DOWNLOAD THE FREE APP



OWNER'S MANUAL - BASIC SETUP DIMENSIONS & ASSEMBLY NOTES

It is critically important that you start with a square and level surface. A concrete pad is recommended to avoid digging and for easy cleaning.

- Pay close attention to items needed for each step and make sure you are using the correct hardware. Incorrect hardware may result in improper assembly.
- Double check for underground utilities and overhead lines.
- While determining location, keep in mind the kennel door position is customizable. See "Choosing a Door Location" in this manual.
- Before building, make sure your location is not too exposed to wind and direct sun.
- Post mounts are provided with your structure which allows you to permanently install your structure to a concrete or dirt surface. See Anchor Instructions for further details and recommendations.

Consider the breed and individual needs of your dog before leaving them outside in hot or cold weather for long periods of time.

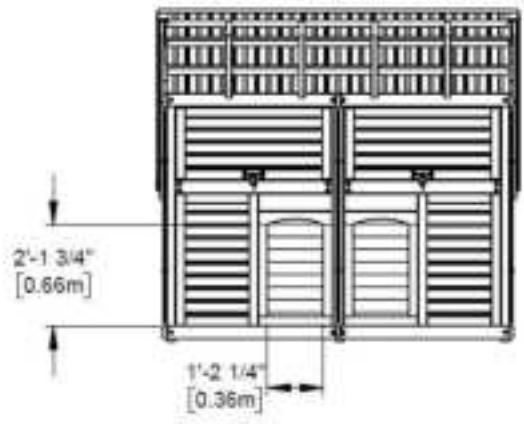
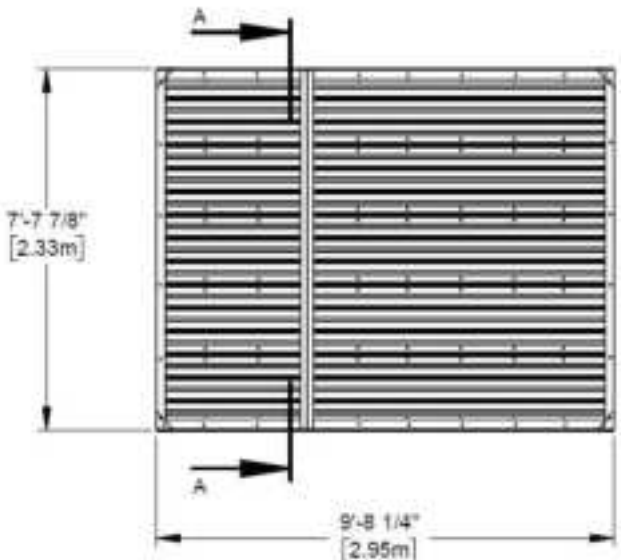
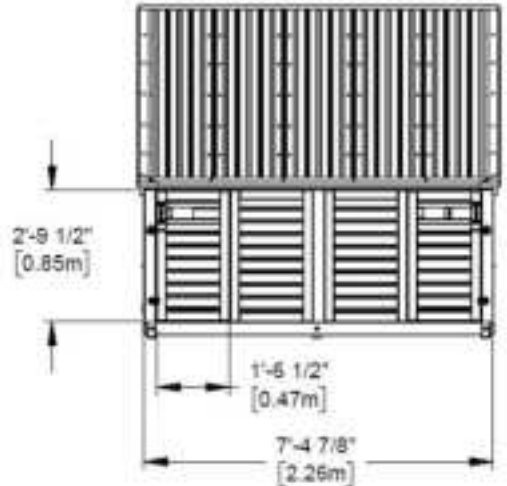
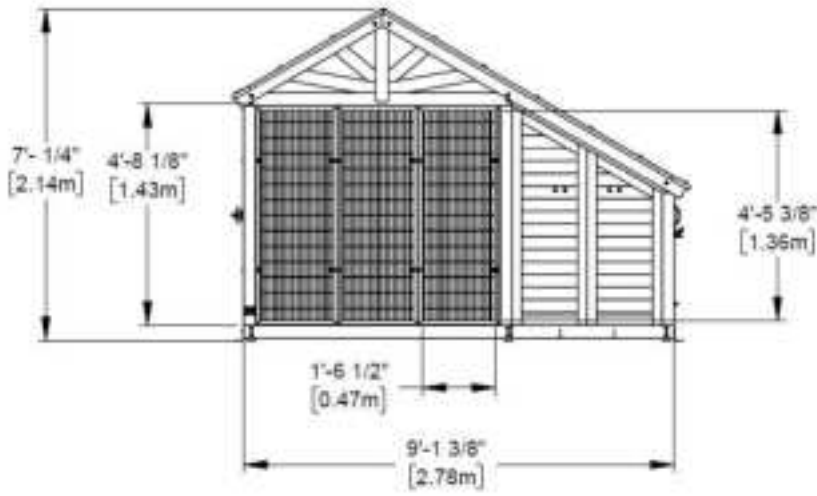

OWNER'S MANUAL - ANCHORING LAYOUT

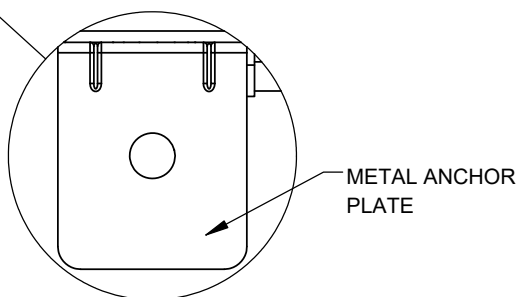
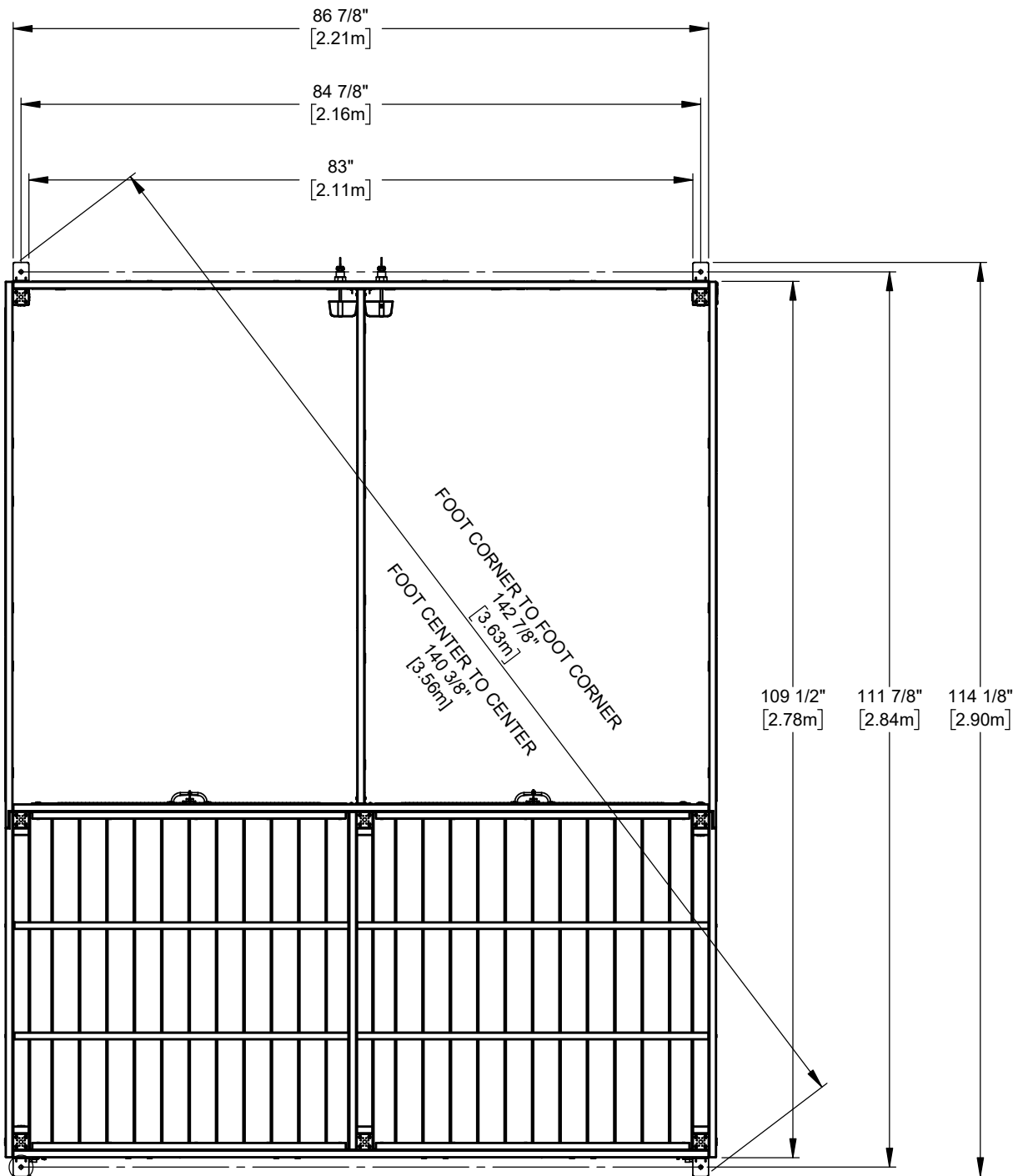

OWNER'S MANUAL - SITE LOCATION AND PREPARATION

- A. Check your local building and city codes for permit requirements or restrictions, including any HOA restrictions.
- B. Select a location with good drainage, and the ability to create a level firm surface for your animal enclosure.
 - A firm, level surface is critically important to the longevity of your animal enclosure.
 - Ensure it is accessible on all sides to clean and conduct annual maintenance
 - Make sure site drains well and avoid low lying areas.
 - Recommended area for site preparation of the animal enclosure is 11'-10 3/8" x 9'-7 7/8" x 7' 1/4" (3089mm x 2943mm x 2159mm).
- C. Before preparing your surface – double check for possibility of any underground utilities (example: gas, cable, or sprinkler lines)
 - Remove any grass, dirt, landscaping to create a level, hard-packed surface
 - This may involve some digging to create a level spot, dependent on your site location.
- D. Determine your preferred site pad materials for your animal enclosure
 - It is NOT recommended to put the animal enclosure directly on soil or grass. This will shorten the lifespan of your kennel.
 - Site pad options include gravel, or concrete surface.
 - Anchors are included for either natural surface, such as gravel, or for a concrete foundation.
 - Manufacturer recommends installation on concrete surface.

OWNER'S MANUAL - PARTS IDENTIFICATION

WOOD COMPONENTS (NOT TO SCALE)



B01 POST-W4L22500
(x1) 3"X3"X62 7/16" (76x76x1586)



B02 POST-W4L22501
(x1) 3"X3"X62 7/16" (76x76x1586)



B03 POST-W4L22503
(x1) 3"X3"X62 7/16" (76x76x1586)



B04 POST-W4L22506
(x1) 3"X3"X40 5/16" (76x76x1024)



B05 POST-W4L22504
(x1) 3"X3"X40 5/16" (76x76x1024)



B06 POST-W4L22502
(x1) 3"X3"X62 7/16" (76x76x1586)



B07 POST-W4L22505
(x1) 3"X3"X40 5/16" (76x76x1024)

OWNER'S MANUAL - PARTS IDENTIFICATION

WOOD COMPONENTS (NOT TO SCALE)



B08 UPRIGHT-W4L22514
(x1) 3"X3"X62 7/16" (76x76x1586)



E1 RAFTER-W4L22530
(x4) 1 7/16"x3 3/8"x40 1/16" (36x86x1017)



E2 RAFTER-W4L22526
(x4) 1 7/16"X3 3/8"X85 1/16" (36x86x2160)



H01 TOP BOARD-W4L22516
(x1) 15/16"X3 3/8"X86 15/16" (24x86x2209)

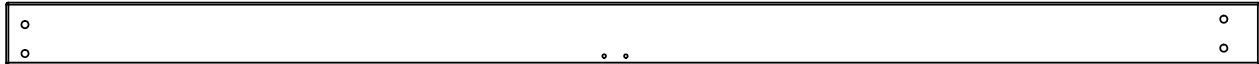

H02 TOP BOARD-W4L22515
(x1) 15/16"X3 3/8"X68 1/4" (24x86x1734)



H04 TOP BOARD-W4L22517
(x1) 15/16"X3 3/8"X68 1/4" (24x86x1734)



H03 GROUND BOARD-W4L22508
(x1) 15/16"X3 3/8"X68 1/4" (24x86x1734)

OWNER'S MANUAL - PARTS IDENTIFICATION

WOOD COMPONENTS (NOT TO SCALE)



H05 TOP BOARD-W4L22519
(x1) 15/16"X3 3/8"X50 3/16" (24x86x1275)



H06 TOP BOARD-W4L22518
(x1) 15/16"X3 3/8"X50 3/16" (24x86x1275)



H07 GROUNDBOARD-W4L22510
(x1) 15/16"X3 3/8"X68 1/4" (24x86x1734)



H08 GROUNDBOARD-W4L22512
(x1) 15/16"X3 3/8"X43 1/4" (24x86x1098)

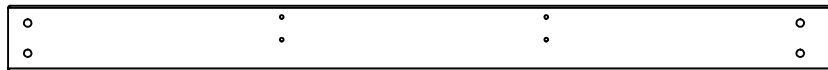

H09 GROUNDBOARD-W4L22507
(x1) 15/16"X3 3/8"X43 1/4" (24x86x1098)



H10 GROUNDBOARD-W4L22513
(x1) 15/16"X3 3/8"X86 15/16" (24x86x2209)



H11 GROUNDBOARD-W4L22522
(x1) 15/16"X3 3/8"X42 5/16" (24x86x1074)

OWNER'S MANUAL - PARTS IDENTIFICATION

WOOD COMPONENTS (NOT TO SCALE)

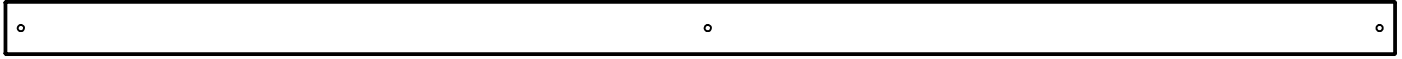

H12 GROUNDBOARD-W4L22511
(x1) 15/16"X3 3/8"X86 15/16" (24x86x2209)



H13 TOP BOARD-W4L22523
(x1) 15/16"X3 3/8"X49 3/8" (24x86x1254)



H14 FLOOR BOARD-W4L22539
(x20) 15/16"X3 3/8"X42 3/16" (24x86x1072)



H15 WALL BOARD-W4L22545
(x1) 15/16"X3 3/8"X39 15/16" (24x86x1014)



H16 GROUNDBOARD-W4L22509
(x2) 15/16"X3 3/8"X64 5/16" (24x86x1634)

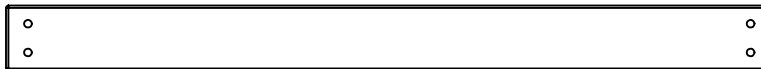

H17 WALL BOARD-W4L22557
(x1) 15/16"X3 3/8"X39 15/16" (24x86x1014)

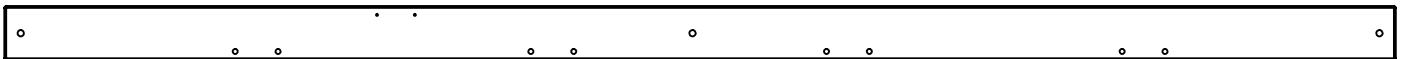

H18 TOP BOARD-W4L22521
(x1) 15/16"X3 3/8"X86 15/16" (24x86x2209)

OWNER'S MANUAL - PARTS IDENTIFICATION

WOOD COMPONENTS (NOT TO SCALE)

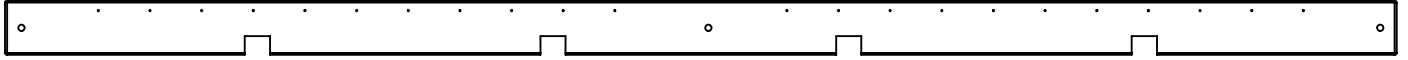

H19 TOP BOARD-W4L22520
(x1) 15/16"x3 3/8"x86 15/16" (24x86x2209)



H20 FASCIA BOARD-W4L22529
(x1) 15/16"x3 3/8"x43 5/16" (24x86x1100)



H21 FASCIA BOARD-W4L22527
(x1) 15/16"x3 3/8"x89 1/2" (24x86x2274)



H22 RIDGE BEAM-W4L22531
(x2) 15/16"x3 3/8"x88 3/4" (24x86x2254)



H25 FASCIA BOARD-W4L22525
(x1) 15/16"x3 3/8"x43 5/16" (24x86x1100)



H26 FASCIA BOARD-W4L22524
(x1) 15/16"x3 3/8"x89 1/2" (24x86x2274)



H27 SHEATHING BOARD-W4L22532
(x7) 15/16"x3 3/8"x88 13/16" (24x86x2256)

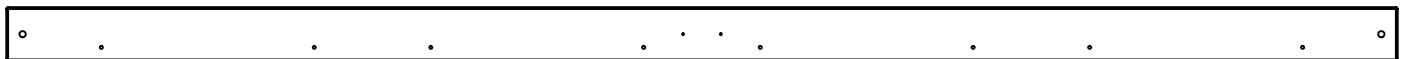

H30 GROUNDBOARD-W4L22509
(x1) 15/16"x3 3/8"x86 15/16" (24x86x2209)

OWNER'S MANUAL - PARTS IDENTIFICATION

WOOD COMPONENTS (NOT TO SCALE)

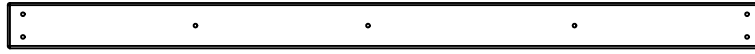

J1 FLOOR JOIST-W4L22537
(x4) 15/16"X2 3/8"X39 5/16" (24x60x998)



J2 FLOOR JOIST-W4L22536
(x2) 15/16"X2 3/8"X44" (24x60x1118)



J3 FLOOR BOARD-W4L22535
(x3) 15/16"X2 1/16"X38 1/8" (24x52x968)

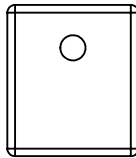

J4 FLOOR CLEAT-W4L22538
(x6) 15/16"X2 1/16"X2 3/8" (24x52x60)



J5 FLOOR JOIST-W4L22543
(x2) 15/16"X2 3/8"X43 11/16" (24x60x1110)



J6 FLOOR JOIST-W4L22544
(x2) 15/16"X2 3/8"X43 11/16" (24x60x1109)



J7 FLOOR JOIST-W4L22540
(x2) 15/16"X2 3/8"X41 7/8" (24x60x1063)



J8 GABLE BOARD-W4L22528
(x2) 15/16"X3 3/8"X19 5/16" (24x86x490)

OWNER'S MANUAL - PARTS IDENTIFICATION

WOOD COMPONENTS (NOT TO SCALE)

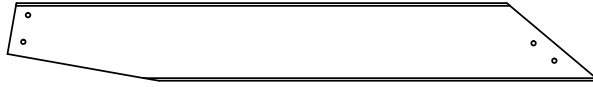

J9 GABLE BOARD-W4L22534
(x4) 15/16"X3 3/8"X25 13/16" (24x86x655)

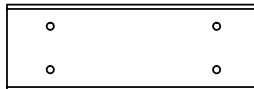

OR01 CLEAT-W4L22542
(x2) 1 3/16"x2 3/8"x6 7/8" (30x60x175)



J11 FLOOR BOARD-W4L22541
(x3) 15/16"X2 13/16"X42 3/16" (24x71x1072)



J12 FLOOR JOIST-W4L22551
(x2) 15/16"X2 3/8"X42 7/16" (24x60x1078)



J13 FLOOR JOIST-W4L22550
(x2) 15/16"X2 3/8"X44 1/2" (24x60x1131)

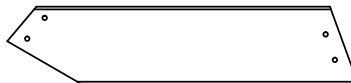

J14 GABLE BOARD-W4L22558
(x4) 15/16"X3 3/8"X15 1/4" (24x86x388)



J15 FLOOR BOARD -W4L23456
(x1) 15/16"X2 13/16"X42 3/16" (24x71x1072)

OWNER'S MANUAL - PARTS IDENTIFICATION

WOOD COMPONENTS (NOT TO SCALE)



L1 FLOORBOARD-W4L22552
(x1) 5/8"x4 5/16"x42 3/16" (16x109x1072)



L2 FLOOR BOARD-W4L22554
(x1) 5/8"x4 1/4"x42 3/16" (16x108x1072)



M1 FLOOR BOARD-W4L22547
(x2) 5/8"x3 3/8"x42 3/16" (16x86x1072)



M3 FLOOR BOARD-W4L22549
(x8) 5/8"x3 3/8"x40 3/16" (16x86x1021)



M4 FLOORBOARD-W4L22548
(x4) 5/8"x3 3/8"x42 3/16" (16x86x1072)



Y1 FLOORBOARD-W4L22553
(x6) 5/8"x3 13/16"x42 3/16" (16x97x1072)

OWNER'S MANUAL - PARTS IDENTIFICATION

WOOD COMPONENTS (NOT TO SCALE)

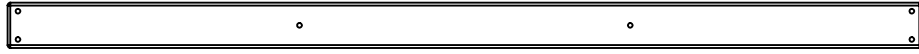

N2 FLOOR BOARD-W4L22546
(x3) 5/8"x1 7/8"x38 1/8" (16x48x968)

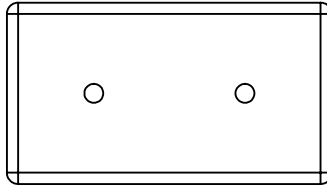

N3 STOP BLOCK-W4L22556
(x2) 5/8"x1 7/8"x3 3/8" (16x48x86)

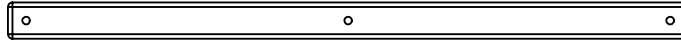

S1 CLEAT-W4L22533
(x4) 15/16"x15/16"x17 11/16" (24x24x450)

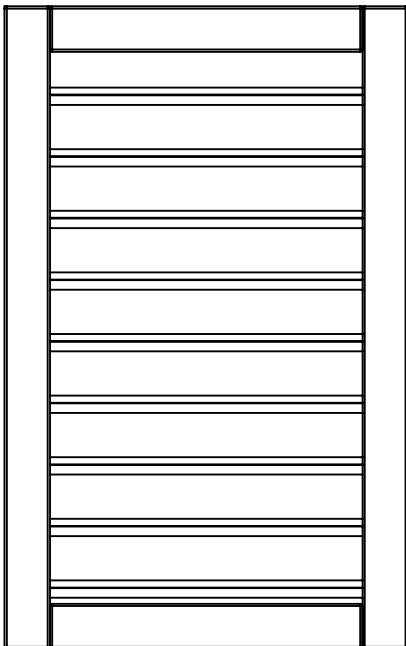

WP1 WALL PANEL-W2A04940
(x1) 1 1/16"x21"x33 1/2" (27x534x850)

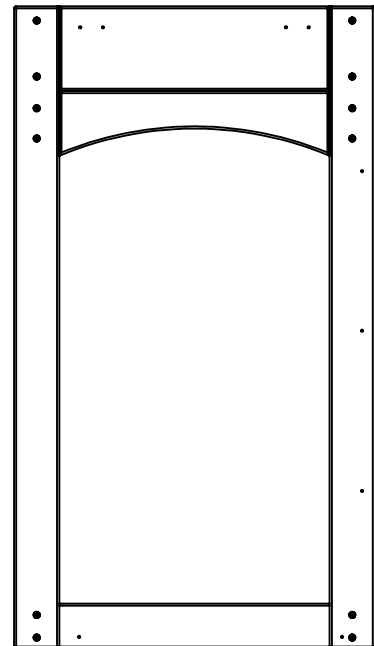

WP2 DOOR FRAME-W2A04941
(x1) 1 7/16"x18 13/16"x29 1/16" (36x478x850)

OWNER'S MANUAL - PARTS IDENTIFICATION

WOOD COMPONENTS (NOT TO SCALE)

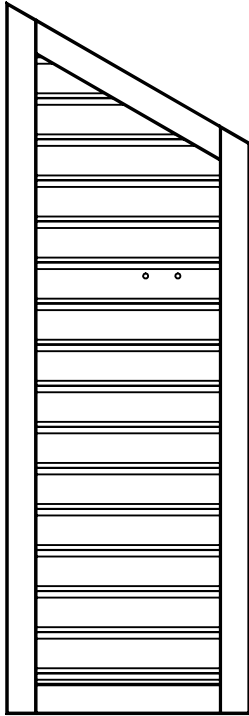

WP3 WALL PANEL-W2A04942
(x1) 1 1/16"X19 1/16"X55 5/8" (27x484x1412)

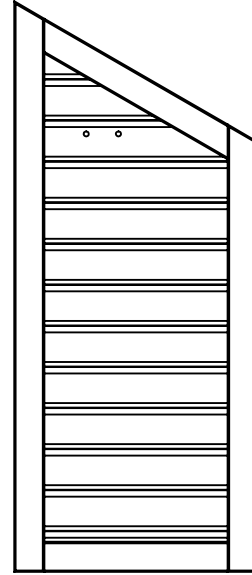

WP4 WALL PANEL-W2A04943
(x1) 1 1/16"X19 1/16"X44 9/16" (27x484x1133)

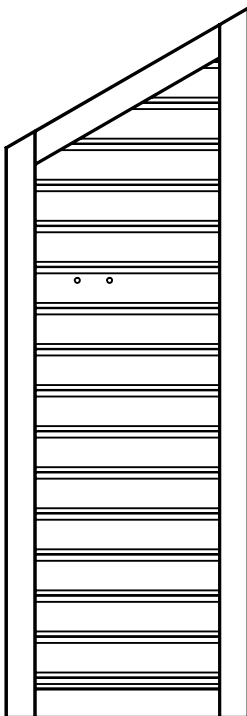

WP5 WALL PANEL-W2A04944
(x1) 1 1/16"X19 1/16"X55 5/8" (27x484x1412)

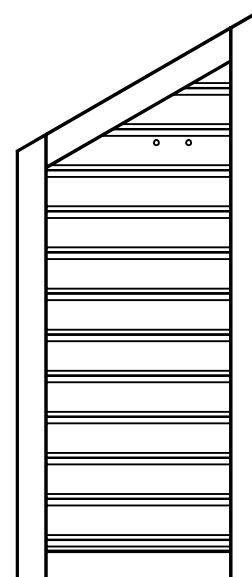

WP6 WALL PANEL-W2A04945
(x1) 1 1/16"X19 1/16"X44 9/16" (27x484x1133)

OWNER'S MANUAL - PARTS IDENTIFICATION

WOOD COMPONENTS (NOT TO SCALE)

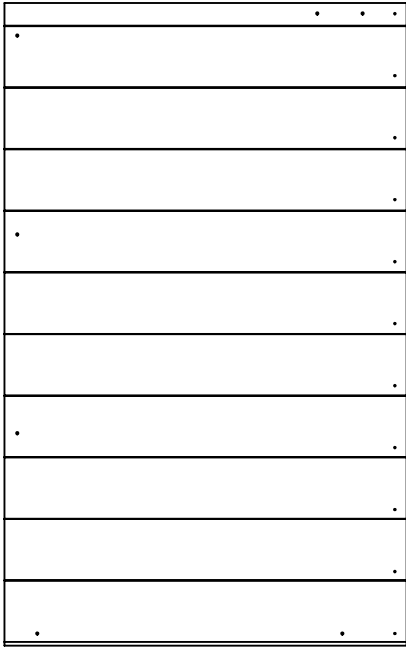

WP7 WALL PANEL-W2A04946
(x1) 1 1/16"X20 15/16"X33 1/2" (27x532x850)

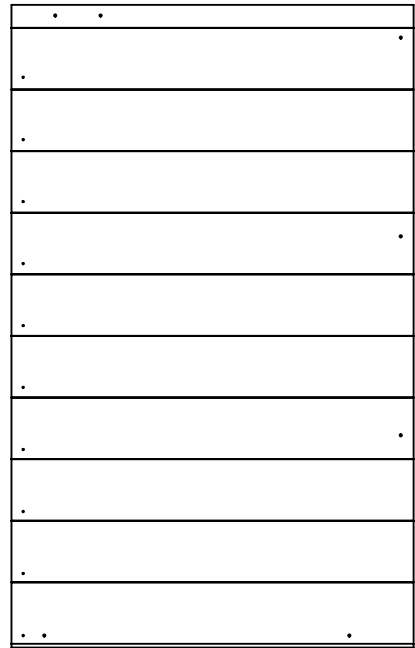

WP8 WALL PANEL-W2A04950
(x1) 1 1/16"X20 15/16"X33 1/2" (27x532x850)

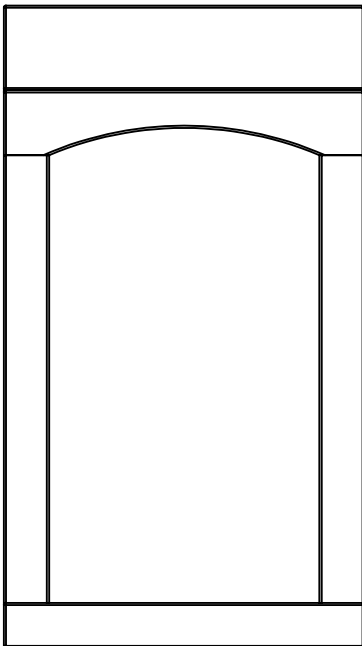

WP9 DOOR FRAME-W2A04951
(x1) 1 7/16"X18 13/16"X29 1/16" (36x478x850)

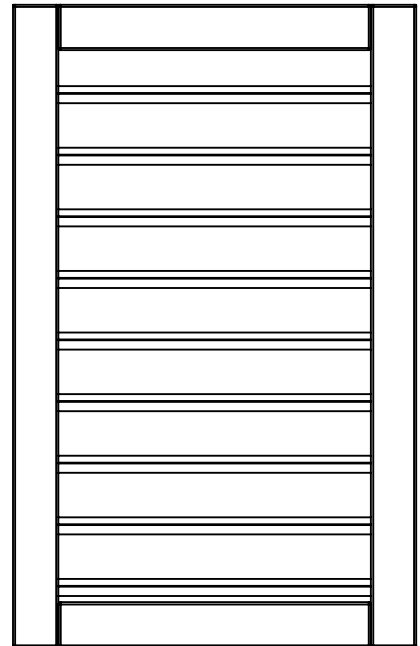

WP10 WALL PANEL-W2A04952
(x1) 1 1/16"X21"X33 1/2" (27x534x850)

OWNER'S MANUAL - PARTS IDENTIFICATION

WOOD COMPONENTS (NOT TO SCALE)

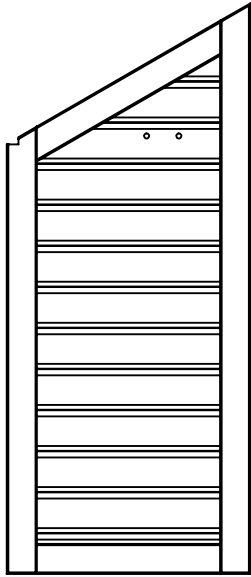

WP11 WALL PANEL-W2A04953
(x1) 1 1/16"X19 1/16"X44 9/16" (27x484x1133)

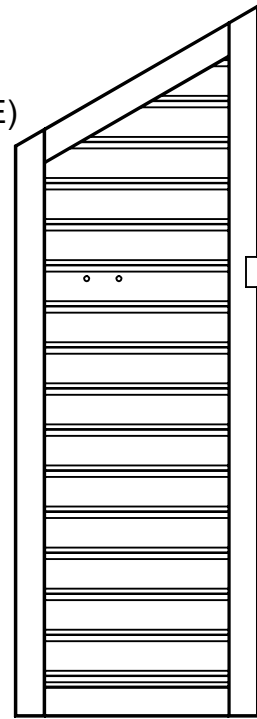

WP12 WALL PANEL-W2A04954
(x1) 1 1/16"X19 1/16"X55 5/8" (27x484x1412)

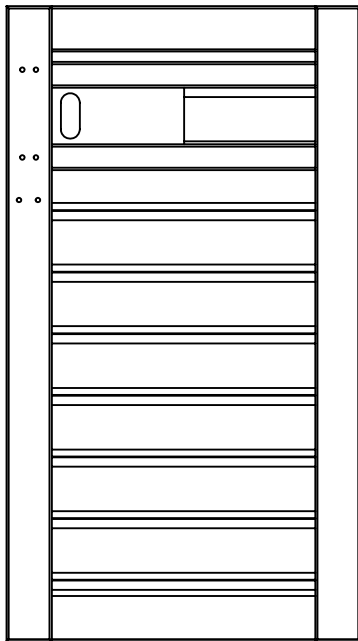

DP1 ENCLOSURE DOOR -W2A04947
(x1) 1 1/4"X18 7/16"X33 1/16" (32x469x840)

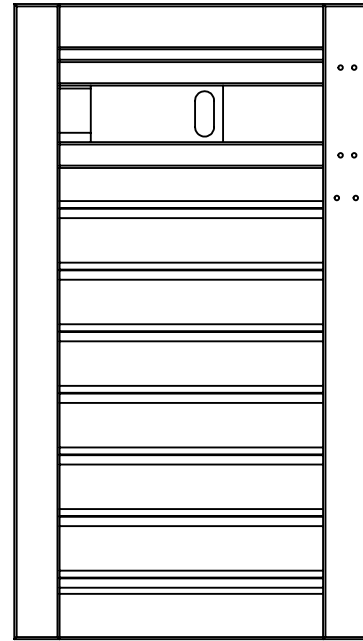

DP2 ENCLOSURE DOOR-W2A04948
(x1) 1 1/4"X18 7/16"X33 1/16" (32x469x840)

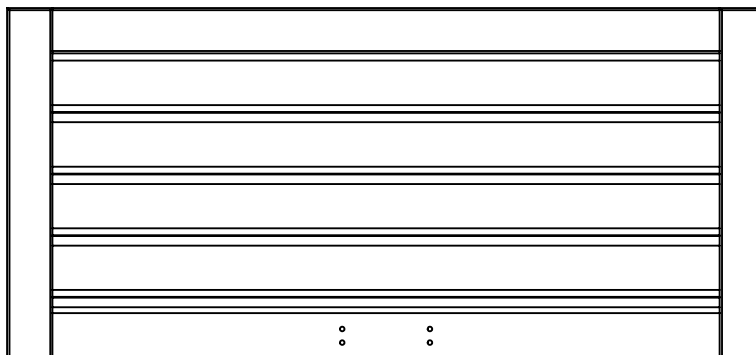

DP3 STORAGE DOOR-W2A04949
(x2) 1 1/16"X18 1/4"X39 7/16" (27x464x1003)

OWNER'S MANUAL - PARTS IDENTIFICATION

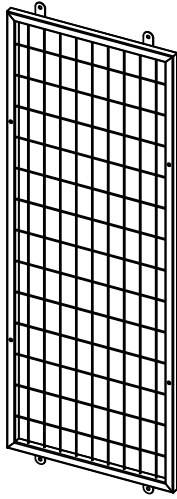

MP01 METAL PANEL-A4M02614
(x11) 1 1/16"X20 1/2"X58 9/16" (27.4x520x1488)

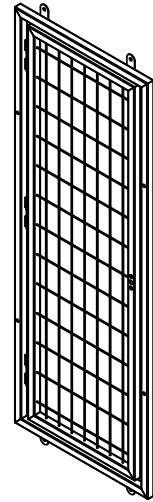

MP04 METAL DOOR PANEL ASSEMBLY-A4M06581
(x2) 1 1/16"X20 1/2"X58 9/16" (27x520x1488)

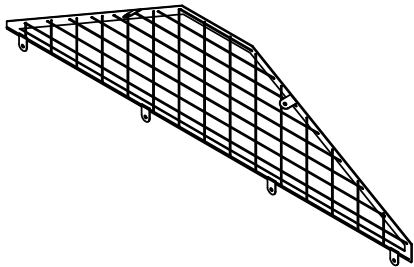

7061 MESH PANEL-A4M07061
(x1) 2 1/16"X18 1/8"X62 5/16" (53.0x459.9x1582.4)

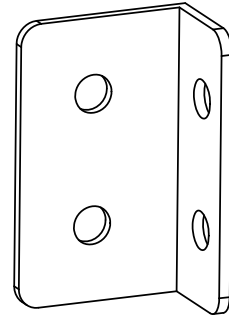

A4M00855 L-BRACKET
(x4)

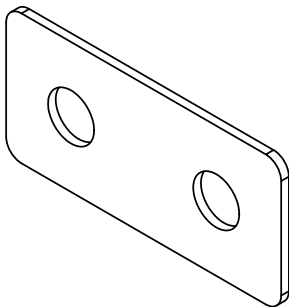

A4M02616 METAL PANEL FLAT BRACKET
(x16)

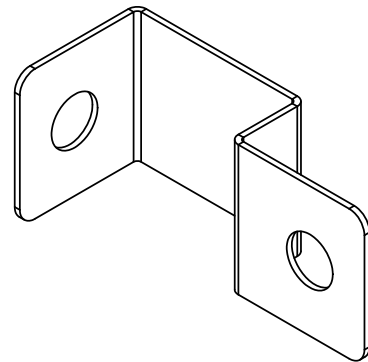

A4M06816 DOOR BRACKET
(x4)

OWNER'S MANUAL - PARTS IDENTIFICATION

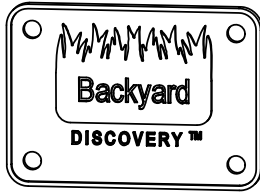

A4M02158 BYD ID TAG PATIO
(x1)

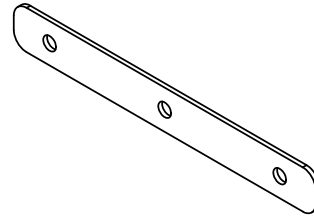

A4M02632 METAL STRAP 118 mm
(x2)

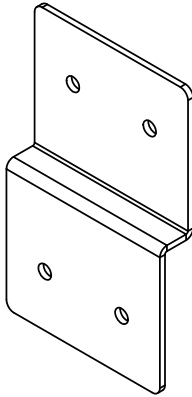

A4M01846 Z-TIE BRACKET
(x4)

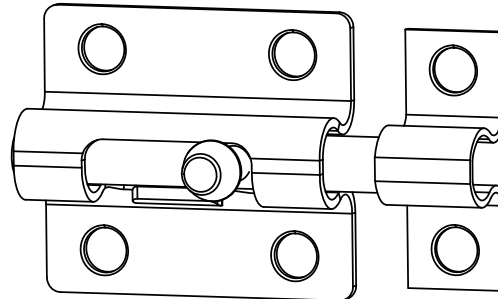

A100266 DEADLOCK
(x2)

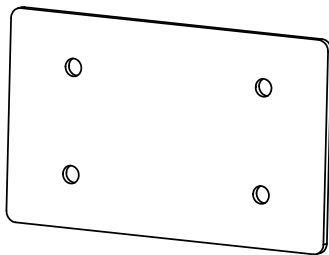

A4M00997 METAL CLEAT
(x16)

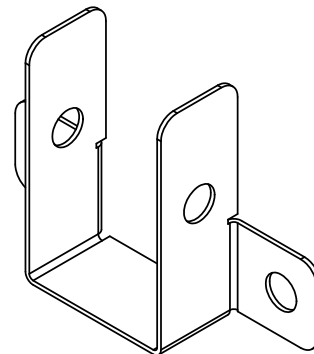

A4M01148 TRUSS BRACKET
(x2)

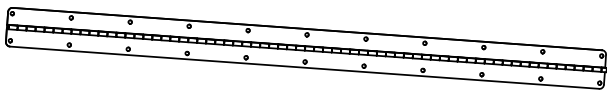

A4M02726 HINGE 832 mm
(x4)

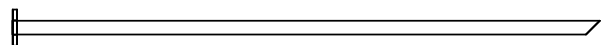

A4M02091 GROUND STAKE
(x4)

OWNER'S MANUAL - PARTS IDENTIFICATION

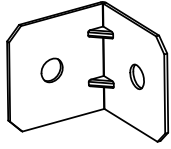

A4M01785 ANGLE BRACKET
(x71)

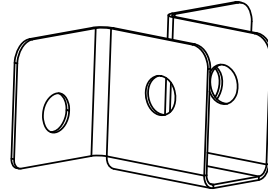

A4M02606 JOIST HANGER 90°
(x8)

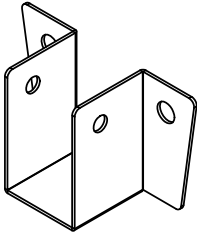

A4M01787 RAFTER BRACKET
(x8)

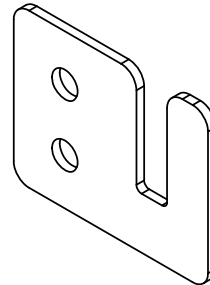

A4M06584 METAL PANEL TAB
(x2)

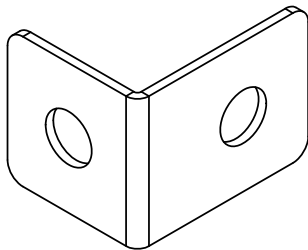

A4M02615 METAL PANEL BRACKET
(x12)

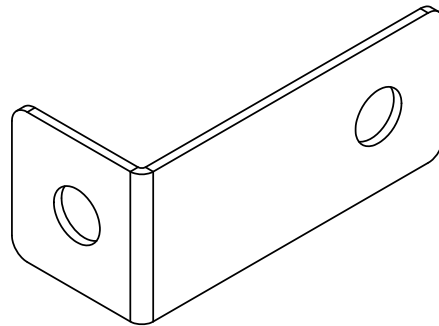

A4M06815 METAL PANEL BRACKET
(x2)

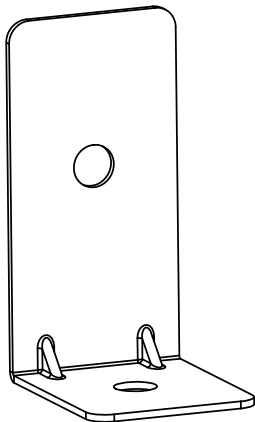

A4M02941 ANCHOR BRACKET
(x4)

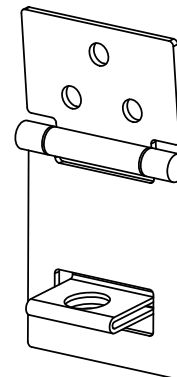

A4M02627 HASP LOCK
(x2)

OWNER'S MANUAL - PARTS IDENTIFICATION

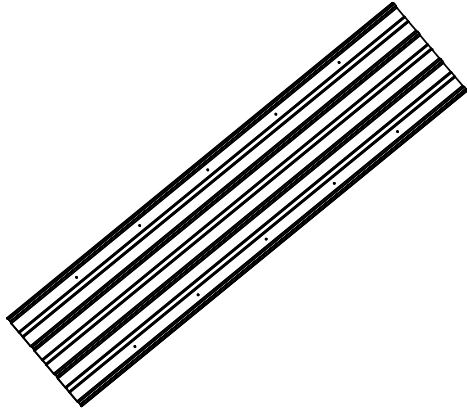

A4M06808 29 GA SHEETING
(x5)

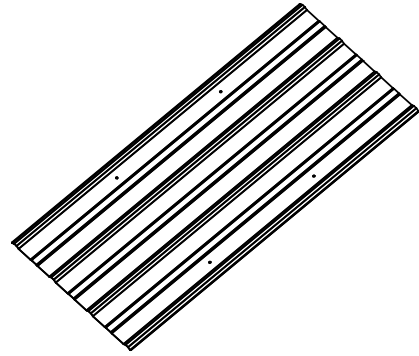

A4M06814 29 GA SHEETING
(x5)

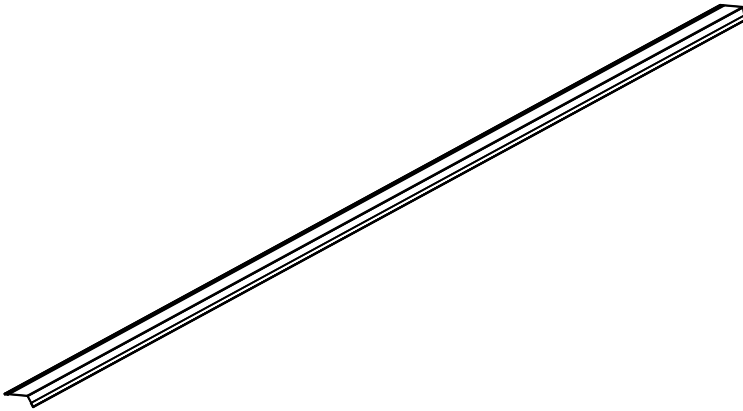

A4M06813 ROOF EDGE TRIM
(x1)

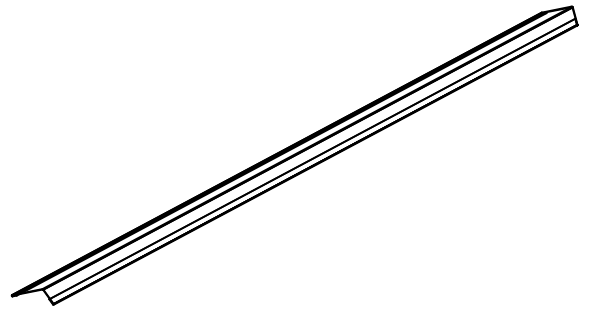

A4M06810 ROOF EDGE TRIM
(x1)

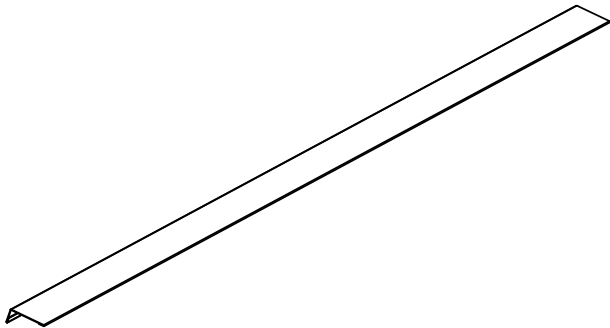

A4M06811 ROOF EDGE TRIM
(x1)

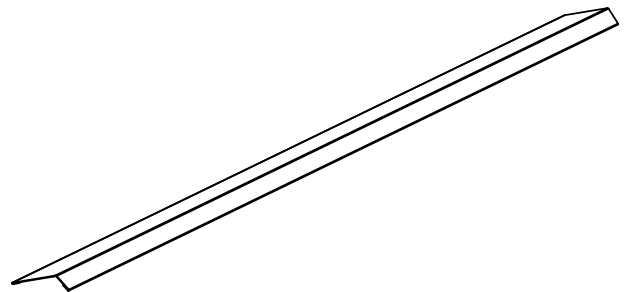

A4M06812 ROOF EDGE TRIM
(x1)



A4M06809 ROOF EDGE TRIM
(x2)

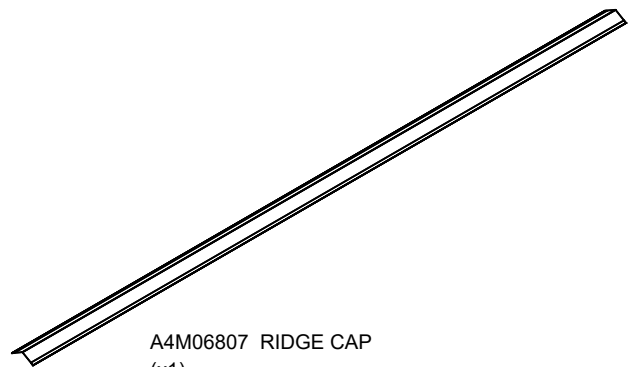

A4M06807 RIDGE CAP
(x1)

OWNER'S MANUAL - PARTS IDENTIFICATION

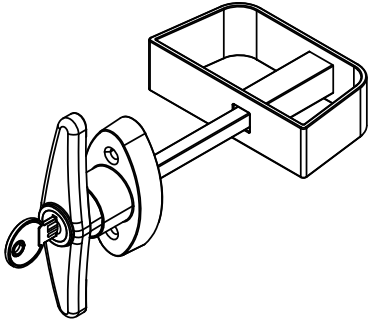

A4M00839 T-HANDLE WITH LOCK
(x2)

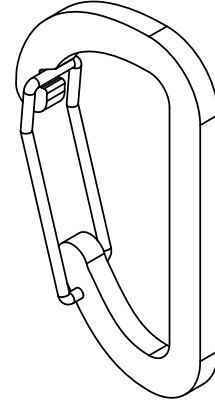

A4M02971 CARABINER
(x4)

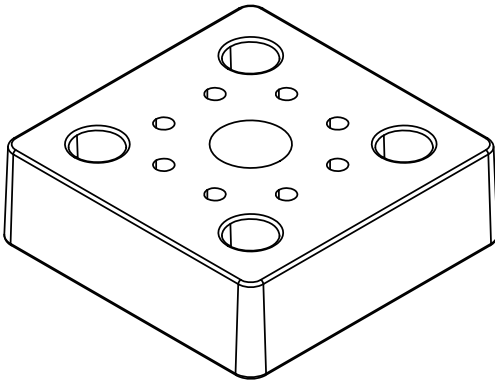

A6P00651 2x2 POST FOOT
(x8)

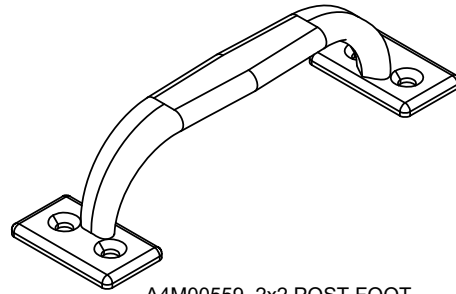

A4M00559 2x2 POST FOOT
(x4) 1 5/16"x1 1/2"x5 1/2"

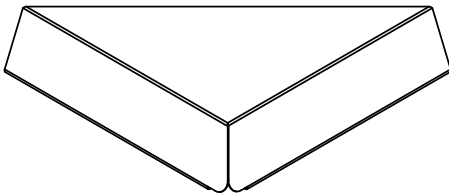

A4M02696 CORNER CAP
(x4)

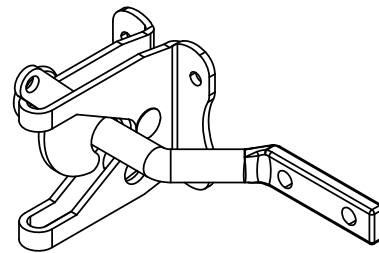

A100264 DOOR LATCH
(x2)

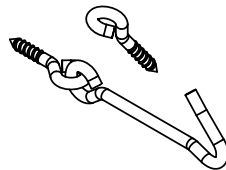

A4M03459 DOOR LATCH
(x2)

OWNER'S MANUAL - PARTS IDENTIFICATION

Hardware Components

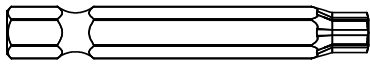

H100147 TORX BIT
(x1) T-30

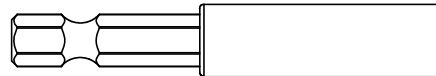

H101100 MAGNETIC DRIVER
(x1)

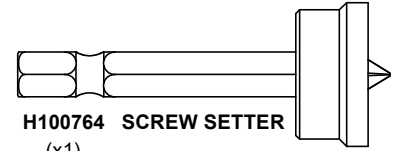

H100764 SCREW SETTER
(x1)

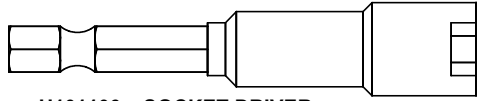

H101106 SOCKET DRIVER
(x1)

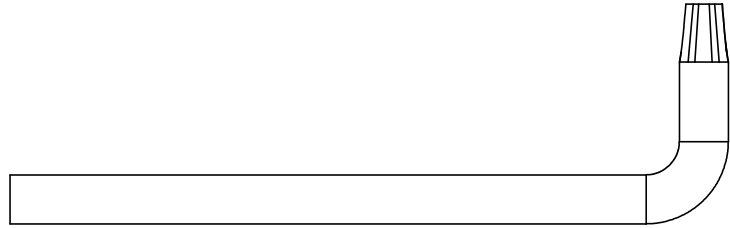

H100114 TORX WRENCH
(x1)

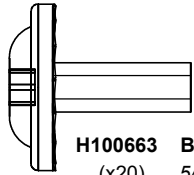

H100663 BOLT WH BLK
(x20) 5/16x3/4

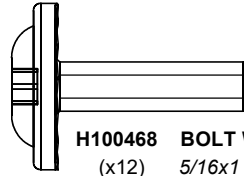

H100468 BOLT WH BLK
(x12) 5/16x1

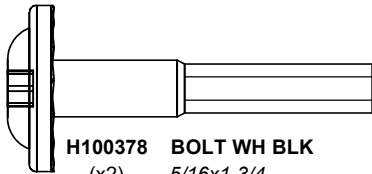

H100378 BOLT WH BLK
(x2) 5/16x1-3/4

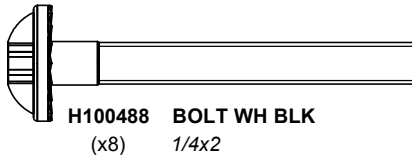

H100488 BOLT WH BLK
(x8) 1/4x2

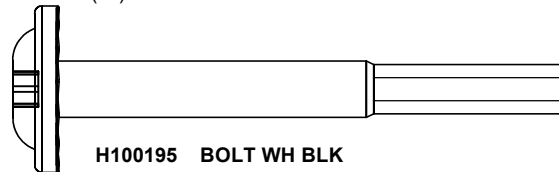

H100195 BOLT WH BLK
(x31) 5/16x2-3/4

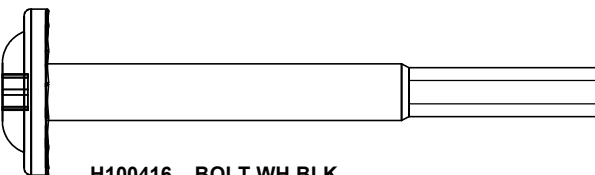

H100416 BOLT WH BLK
(x2) 5/16x3

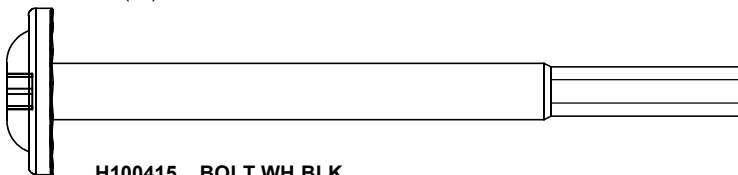

H100415 BOLT WH BLK
(x15) 5/16x3-3/4

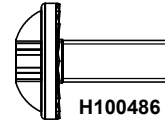

H100486 BOLT WH BLK
(x64) 1/4x5/8

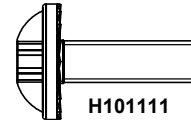

H101111 BOLT WH BLK
(x4) 1/4x3/4



H100460 LAG SCREW WH BLK
(x74) 1/4x1

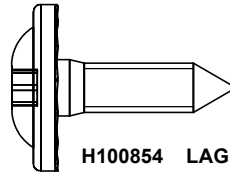

H100854 LAG SCREW WH BLK
(x8) 5/16x1

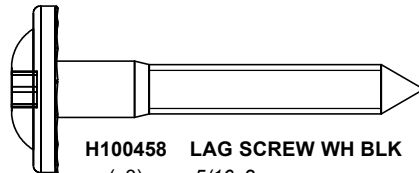

H100458 LAG SCREW WH BLK
(x3) 5/16x2



H100653 NUT LOCK BLK
(x12) 1/4

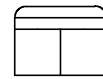

H100479 NUT LOCK BLK
(x12) 5/16

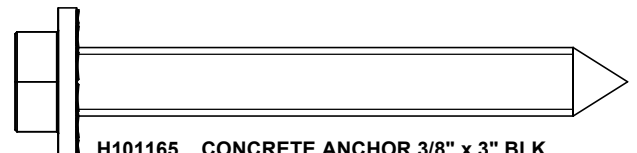

H101165 CONCRETE ANCHOR 3/8" x 3" BLK
(x4)

OWNER'S MANUAL - PARTS IDENTIFICATION

Hardware Componentes

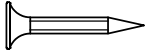

H100627 SCREW PFH BLK
(x88) 6x3/4



H100395 SCREW PFH BLK
(x4) 8x3/4

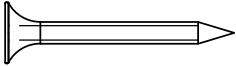

H100387 SCREW PFH BLK
(x150) 8x1-1/4

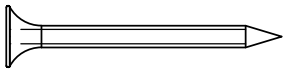

H100200 SCREW PFH BLK
(x112) 8x1-1/2

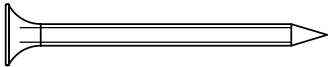

H100382 SCREW PFH BLK
(x64) 8x1-3/4



H100391 SCREW PFH BLK
(x194) 8x2

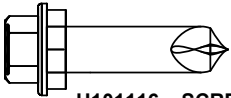

H101116 SCREW SELF TAPPING
(x42) 1/4 x 1

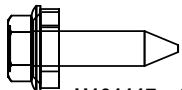

H101117 SCREW WOODGRIP
(x70) 10x3/4

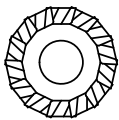

H100405 WASHER LOCK EXT BLK
(x16) 6x15

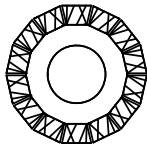

H100198 WASHER LOCK EXT BLK
(x76) 8x19

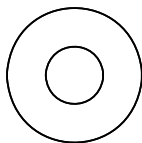

H100630 WASHER FLAT BLK
(x16) 8x19

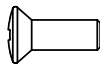

H101401 SCREW POH BLK
(x4) 8/32 x 1/2

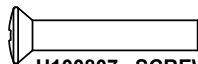

H100807 SCREW POH BLK
(x4) 8/32 x 1 1/4

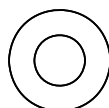

H101133 WASHER FLAT BLK
(x8) 7x14



H100202 SCREW PWH BLK
(x6) 8x5/8

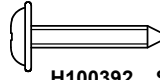

H100392 SCREW PWH BLK
(x187) 8x3/4

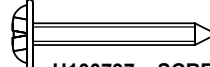

H100797 SCREW PWH BLK
(x47) 8x1

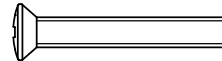

H100806 SCREW POH BLK
(x16) 8-32 x 1 1/8

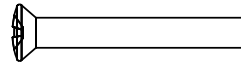

H101076 SCREW POH BLK
(x4) 8/32 x 1 1/4

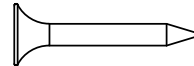

H100385 SCREW POH BLK
(x4) 8/32 x 1 1/4

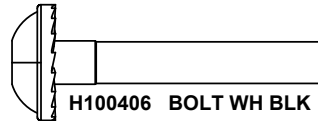

H100406 BOLT WH BLK
(x4) 1/4 x 1 1/2

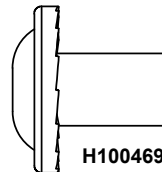

H100469 NUT BARREL WH BLK
(x22) 5/16x5/8

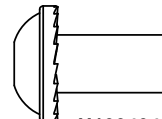

H100404 NUT BARREL WH BLK
(x68) 1/4x5/8



H100804 T-NUT 8/32
(x20)

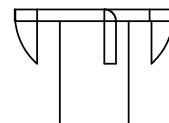

H100379 T-NUT BLK
(x48) 5/16

PRE-ASSEMBLY STEP 1 - SORTING PARTS

It is critical for ease of assembly that you take the time to sort and organize the wood and hardware.

WOOD PARTS:

- Organize wood parts by the three-digit, alpha-numeric number stamped on each board (ex. P01).
- If there are multiple boards with the same stamped number, stack those pieces together.
- Stamps can be found on the flat surface of the boards or on the end of the boards.
- Allow yourself plenty of room - the wood pieces can take up a significant amount of space.

NOTE: CARTONS ARE NOT ORGANIZED BY BOARD NUMBER.



HARDWARE PARTS:

- We recommend that you have a separate table to organize the hardware.
- Hardware bags are printed with a seven-digit, alpha-numeric part number.
- You can organize your hardware by part number or group by hardware type (i.e. bolts, nuts, etc.).
- During assembly you only need to reference the last four digits of the number.

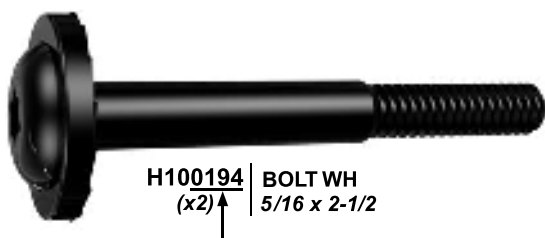

PRE-ASSEMBLY STEP 2 - TOOLS REQUIRED



Cordless Drill
or Electric Drill



Drill
Attachments:
Phillips Head



1/8", 3/16", 3/8" &
7/16" Drill Bits



Phillips Screw Driver



Open End
Wrenches 1/2" &
9/16"



3/8" Drive Ratchet, 1/2" &
7/16" STD Sockets 1/2" & 7/16"
Deep Sockets



Claw Hammer



Rubber Mallet
- Optional

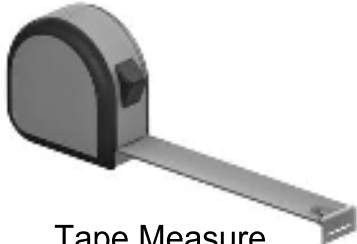

Tape Measure

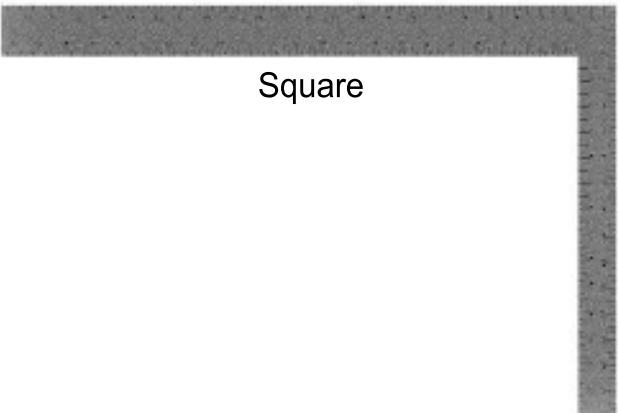

Square



Level 24"

PRE-ASSEMBLY STEP 3 - CHOOSE YOUR ASSEMBLY METHOD

There are several types of assembly instructions available to you.

1. Printed Assembly Manual included with your set
2. BILT APP - 3D interactive instructions
3. Combination of the Printed Manual and BILT APP (Note: Step numbers can differ between the two methods)

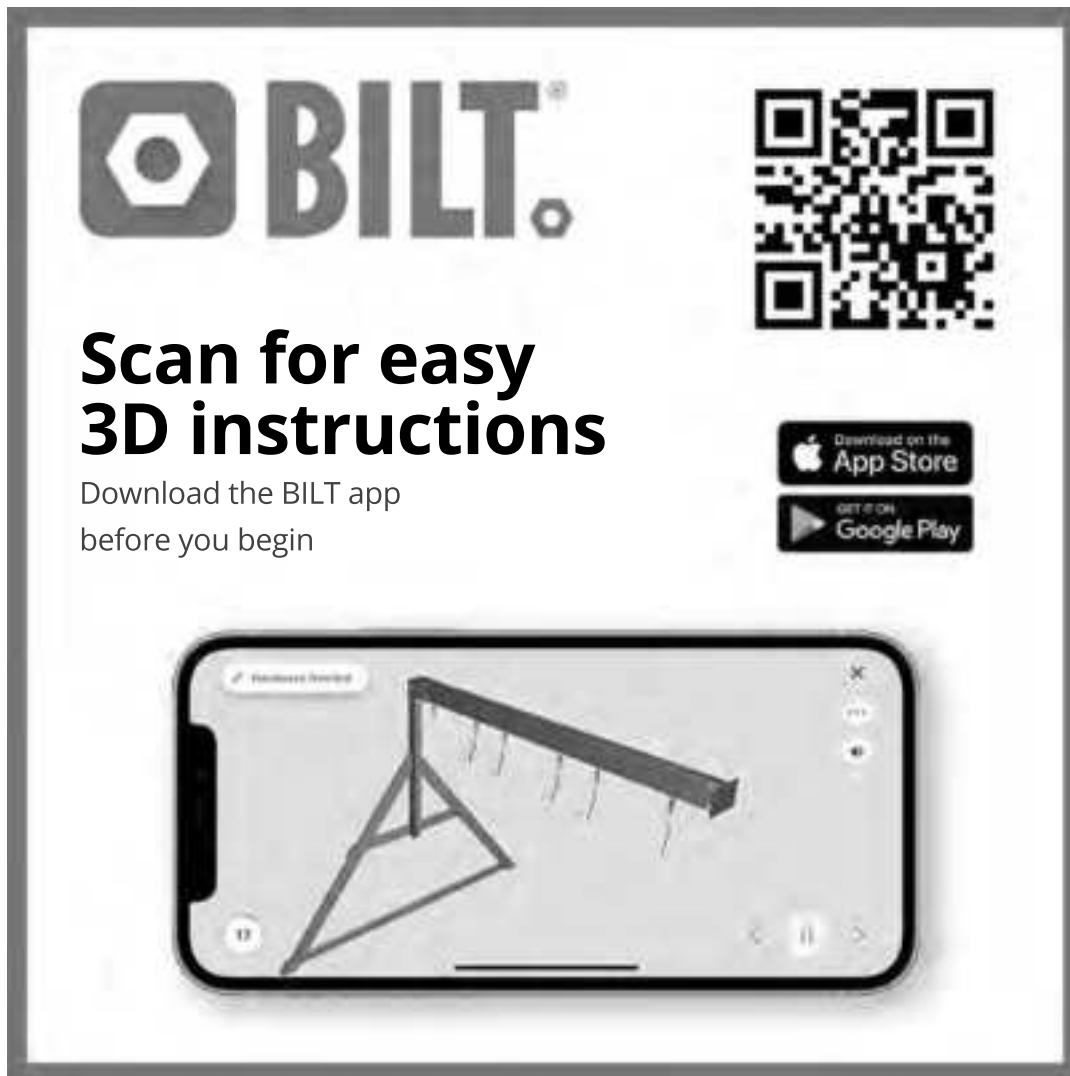

The graphic features the BILT logo at the top left, a QR code at the top right, and the text "Scan for easy 3D instructions" in large bold font. Below this, it says "Download the BILT app before you begin". To the right are buttons for "Download on the App Store" and "GET IT ON Google Play". At the bottom is a smartphone displaying a 3D assembly instruction for a truss structure.

BILT.

**Scan for easy
3D instructions**

Download the BILT app
before you begin

Download on the
App Store

GET IT ON
Google Play

Hardware Overview

11

STEP 1 - B01 POST ASSEMBLY

QTY	PART NUMBER	DESCRIPTION
4	H100460	LAG SCREW WH 1/4x1 BLK
5	H100379	T-NUT 5/16 BLK
4	H100200	SCREW PFH 8x1 1/2 BLK



B01 POST - W4L22500
(x1) 3"x3"x82 7/16" (76x76x1586)



A6P00651 2x2 POST FOOT
(x1)



A4M02615 METAL PANEL BRACKET
(x4)

- INSTALL T-NUTS FIRST

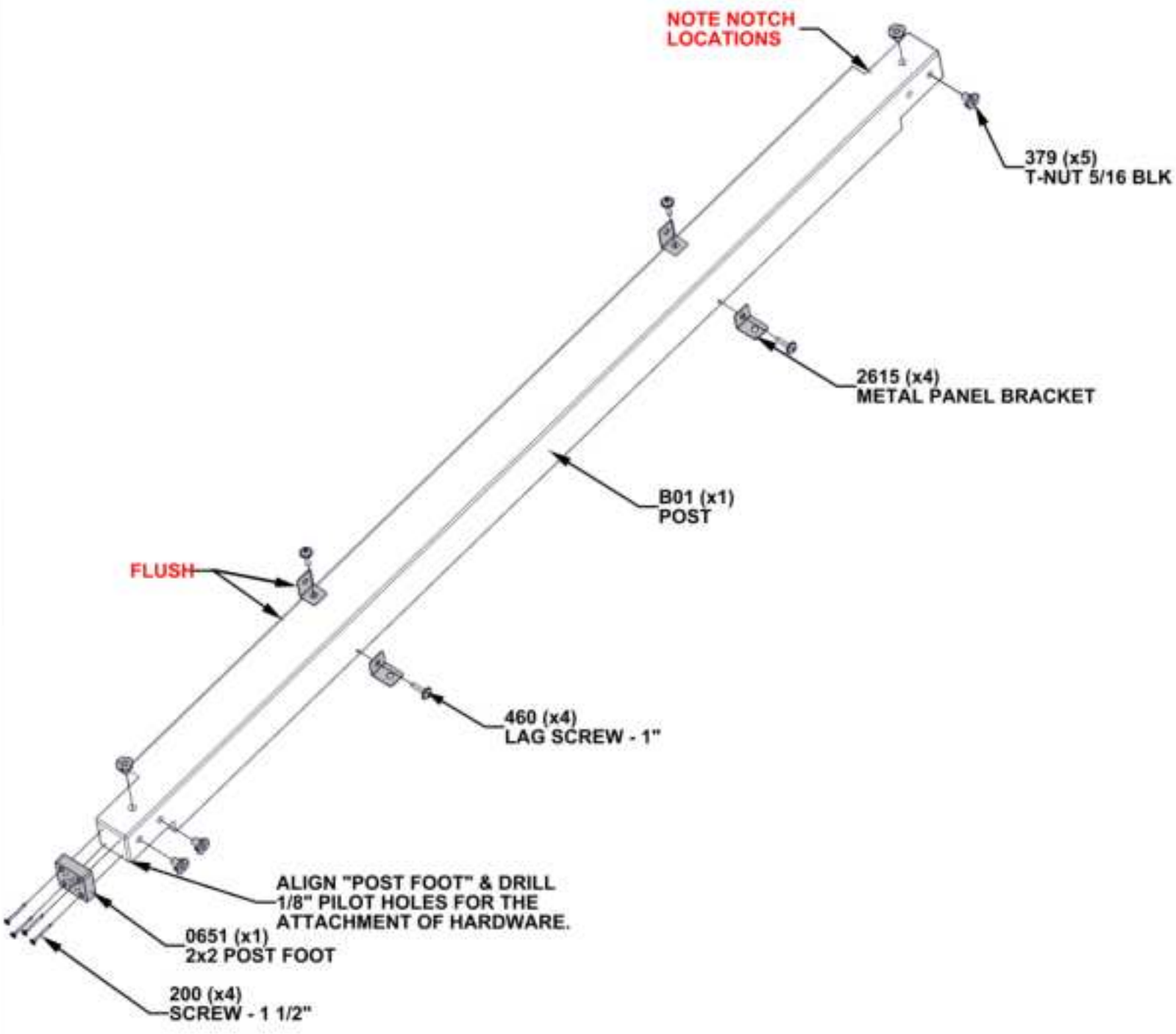

STEP 2 - B02 POST ASSEMBLY

QTY	PART NUMBER	DESCRIPTION
4	H100460	LAG SCREW WH 1/4x1 BLK
5	H100379	T-NUT 5/16 BLK
4	H100200	SCREW PFH 8x1 1/2 BLK



B02 POST - W4L22501
(x1) 3"x3"x62 7/16" (76x76x1586)



A6P00651 2x2 POST FOOT
(x1)



A4M02615 METAL PANEL BRACKET
(x4)

- INSTALL T-NUTS FIRST

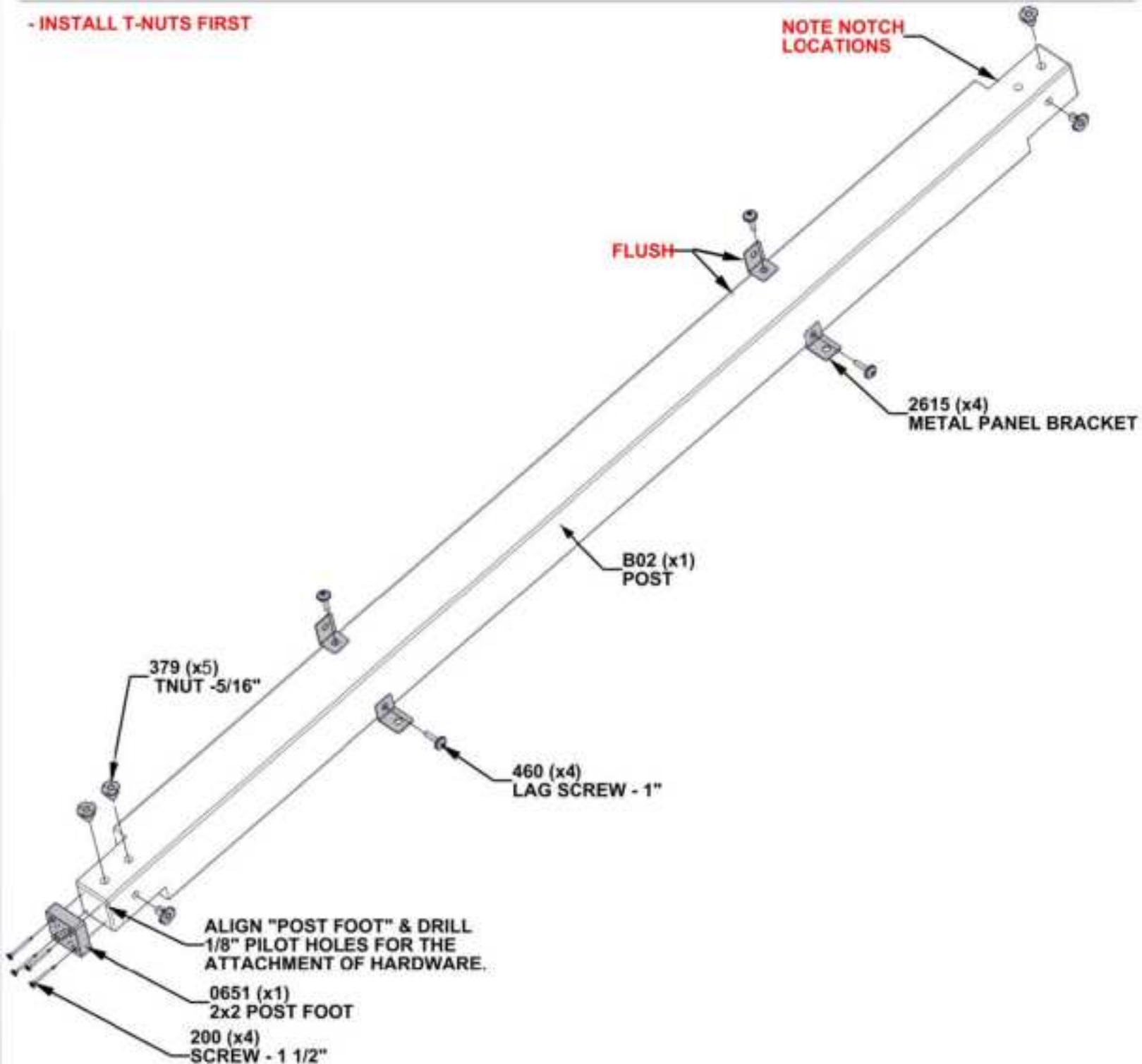

STEP 3 - ANIMAL ENCLOSURE ASSY

QTY	PART NUMBER	DESCRIPTION
2	H100416	BOLT WH 5/16x3 BLK
2	H100198	WASHER LOCK EXT 8x19
2	H100195	BOLT WH 5/16x2 3/4 BLK

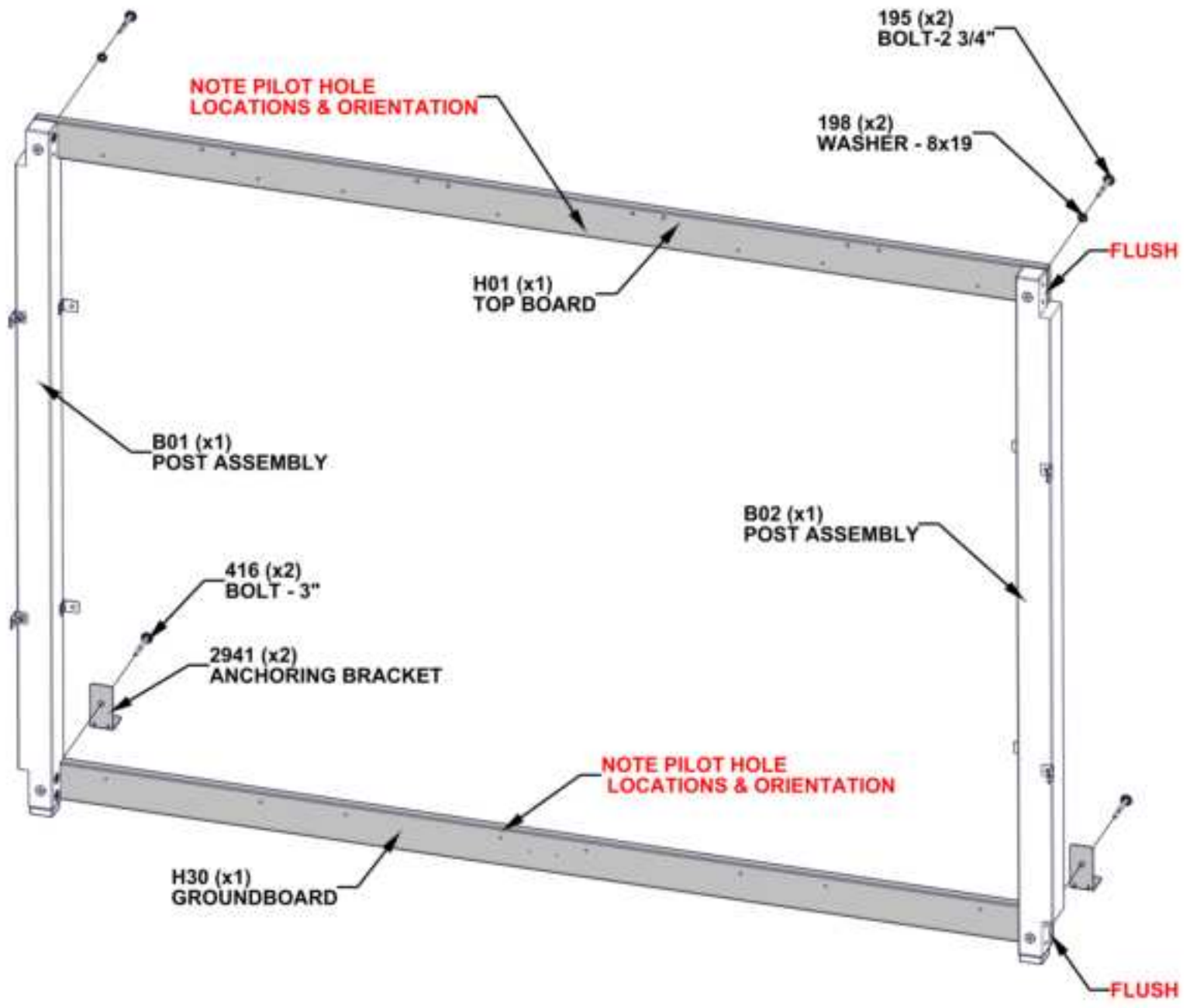
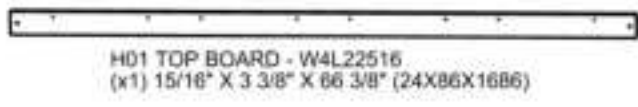
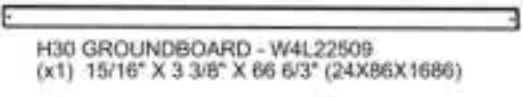
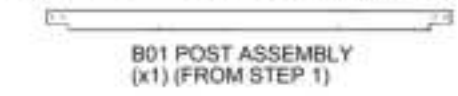

STEP 4 - B03 POST ASSEMBLY

QTY	PART NUMBER	DESCRIPTION
2	H100460	LAG SCREW WH 1/4x1 BLK
4	H100379	TNUT-5/16" BLK
4	H100200	SCREW PFH 8x1 1/2 BLK



B03 POST - W4L22503
(x1) 3" x 3" x 62 7/16" (76x76x1586)



A6P00651 2x2 POST FOOT
(x1)



A4M02615 METAL PANEL BRACKET
(x2)

- INSTALL T-NUTS FIRST

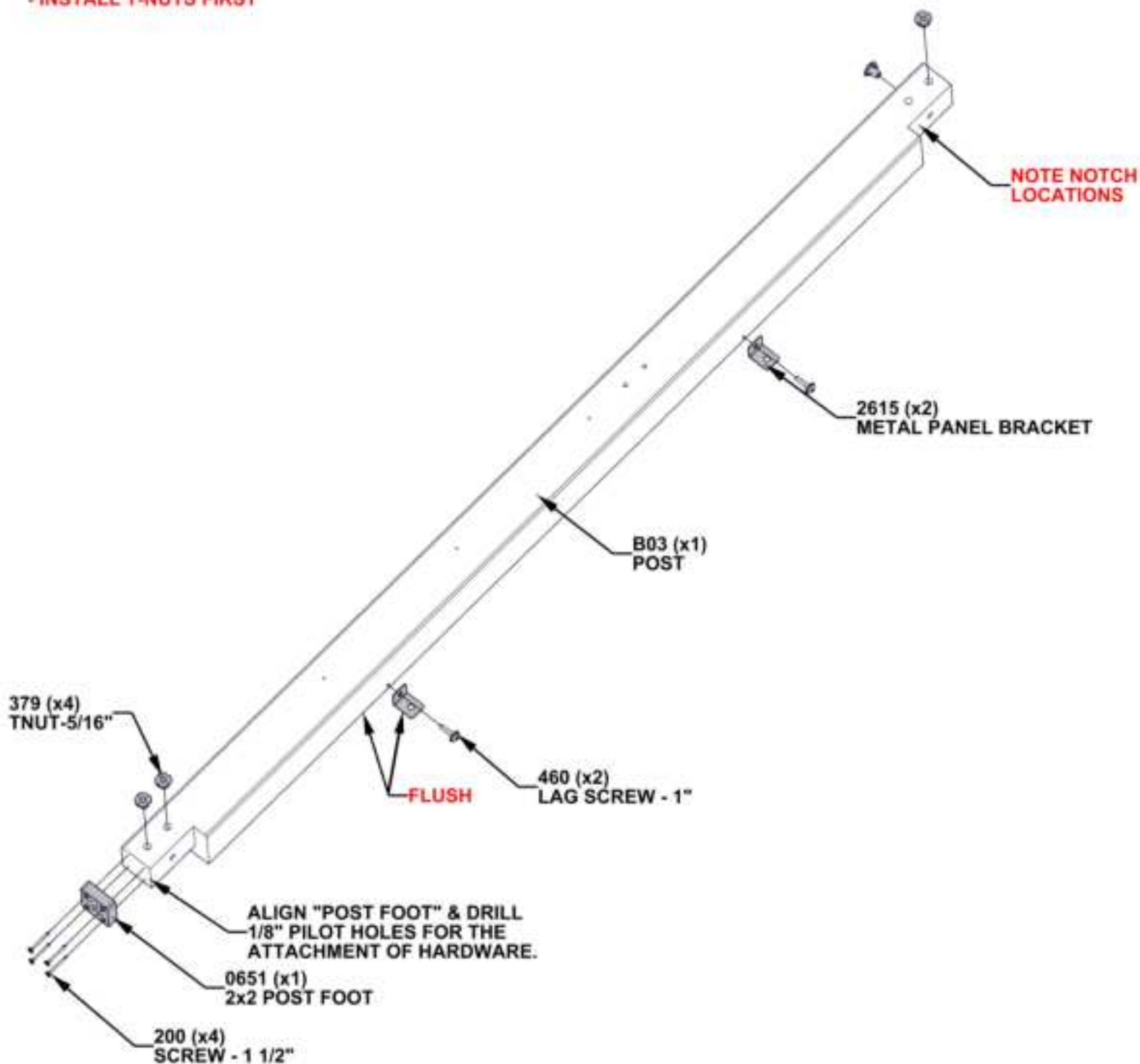

STEP 5 - B06 POST ASSEMBLY

QTY	PART NUMBER	DESCRIPTION
2	H100460	LAG SCREW WH 1/4x1 BLK
2	H100379	TNUT-5/16" BLK
4	H100200	SCREW PFH 8x1 1/2 BLK



B06 POST W4L22502
(x1) 3" X 3" x 62 7/16" (76x76x1586)



A6P00651 2x2 POST FOOT
(x1)



A4M06815 METAL PANEL BRACKET
(x2)

- INSTALL T-NUTS FIRST

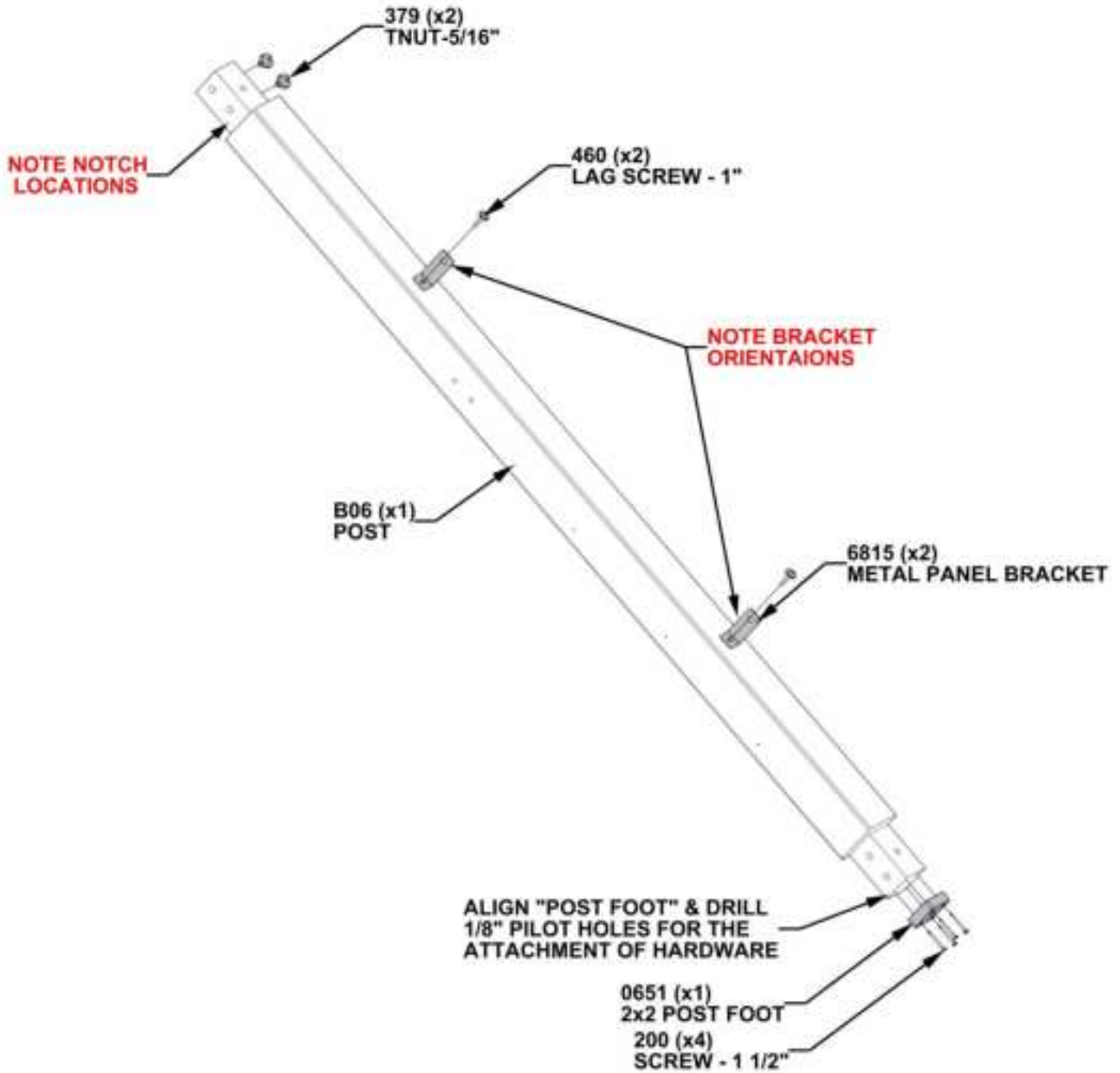

STEP 6 - B08 POST ASSEMBLY

QTY	PART NUMBER	DESCRIPTION
2	H100460	LAG SCREW WH 1/4x1 BLK
4	H100379	TNUT-5/16" BLK
4	H100200	SCREW PFH 8x1 1/2 BLK



B08 POST - W4L22514
(x1) 3"X3"82 7/16" (76x76x1586)



A6P00651 2x2 POST FOOT
(x1)



A4M02615 METAL PANEL BRACKET
(x2)

- INSTALL T-NUTS FIRST

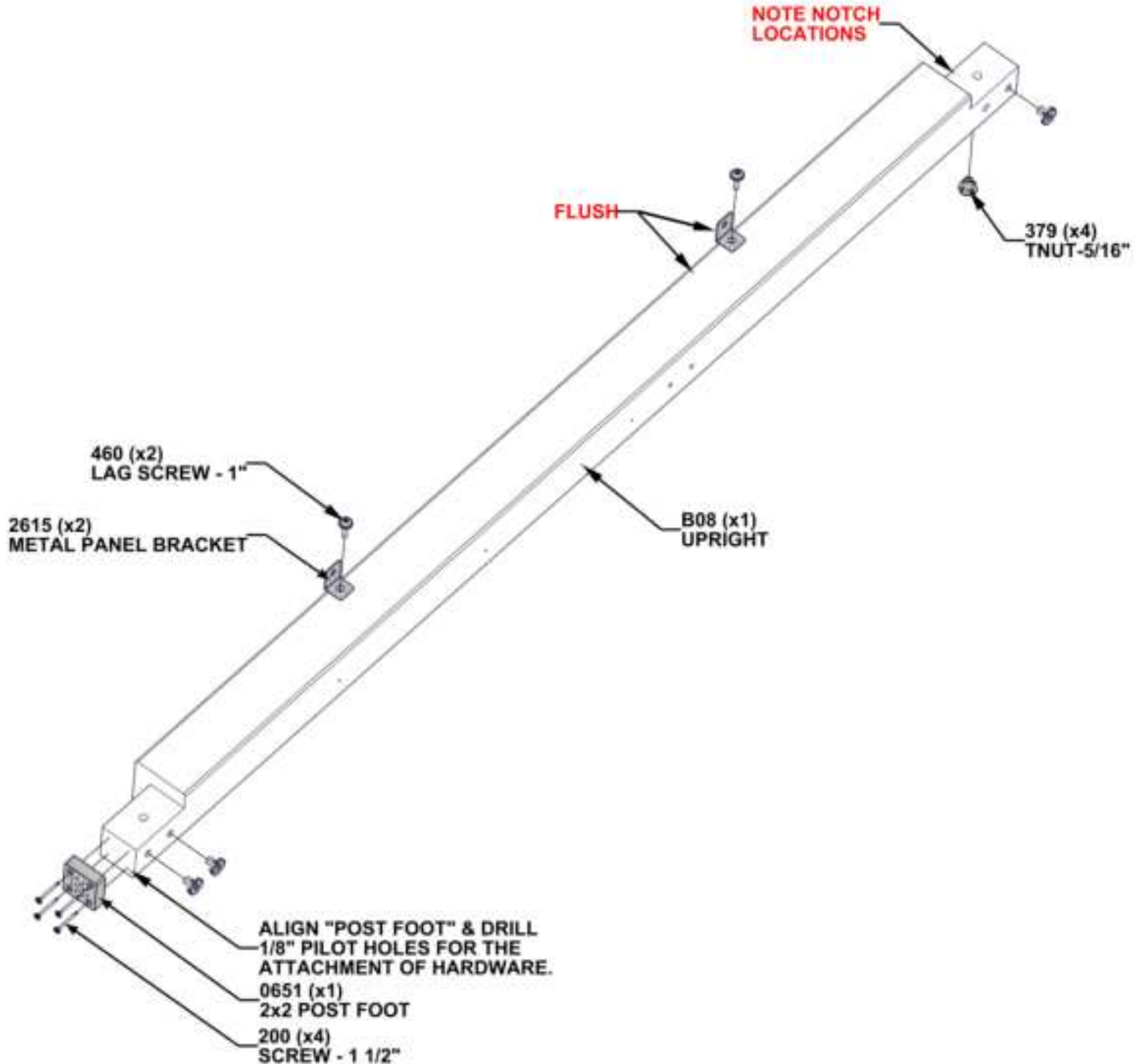

STEP 7 - ANIMAL ENCLOSURE ASSY

QTY	PART NUMBER	DESCRIPTION
3	H100415	BOLT WH 5/16x3 3/4 BLK
4	H100379	TNUT-5/16" BLK
6	H100198	WASHER LOCK EXT 8x19
3	H100195	BOLT WH 5/16x2 3/4 BLK



- INSTALL T-NUTS FIRST

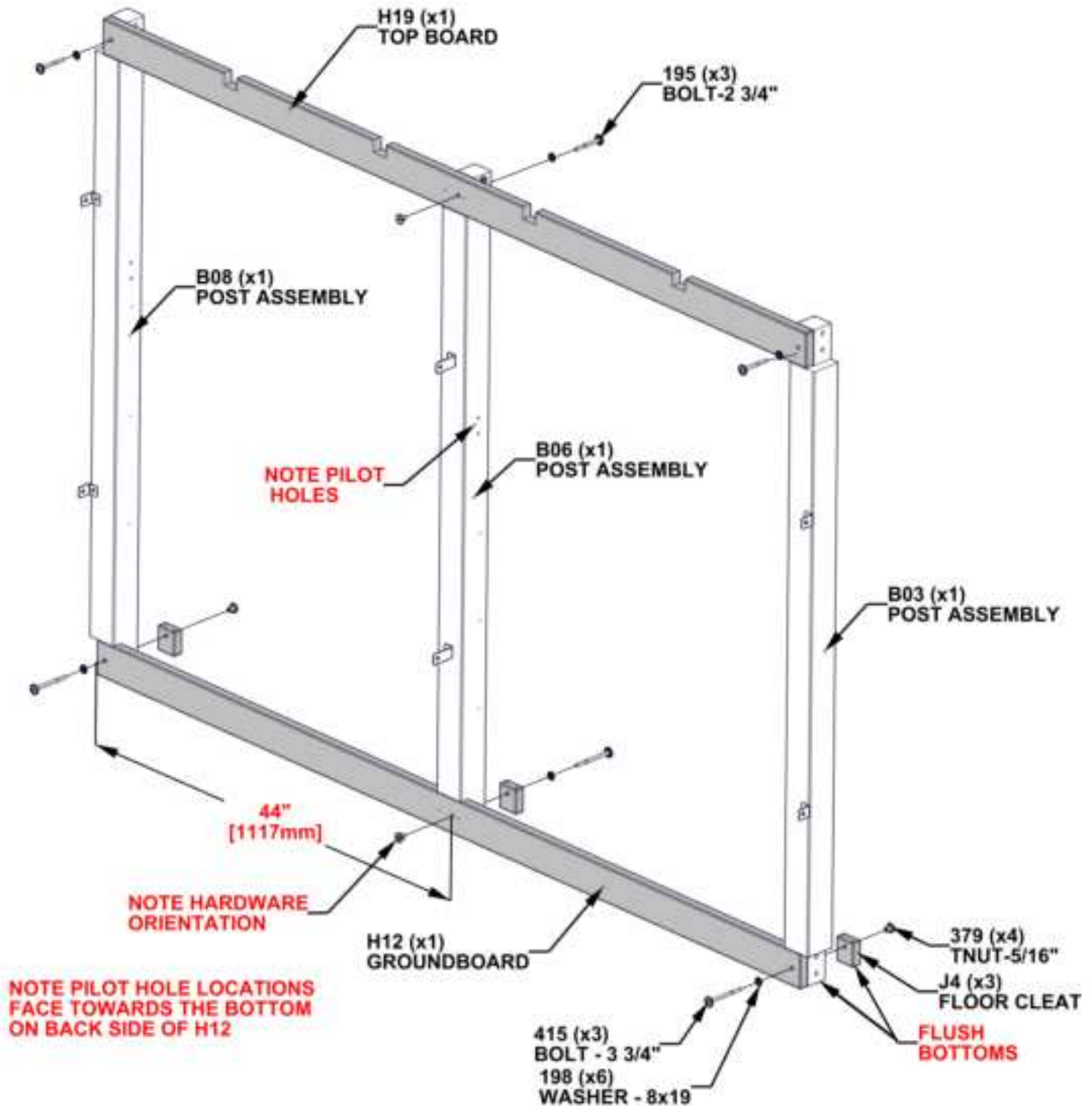

STEP 8 - B05 POST ASSEMBLY

QTY	PART NUMBER	DESCRIPTION
3	H100379	TNUT-5/16" BLK
4	H100200	SCREW PFH 8x1 1/2 BLK



B05 POST W4L22504
(x1) 3" x 3" x 40 5/16" (76x76x1024)



A6P00651 2x2 POST FOOT
(x1)

- INSTALL T-NUTS FIRST

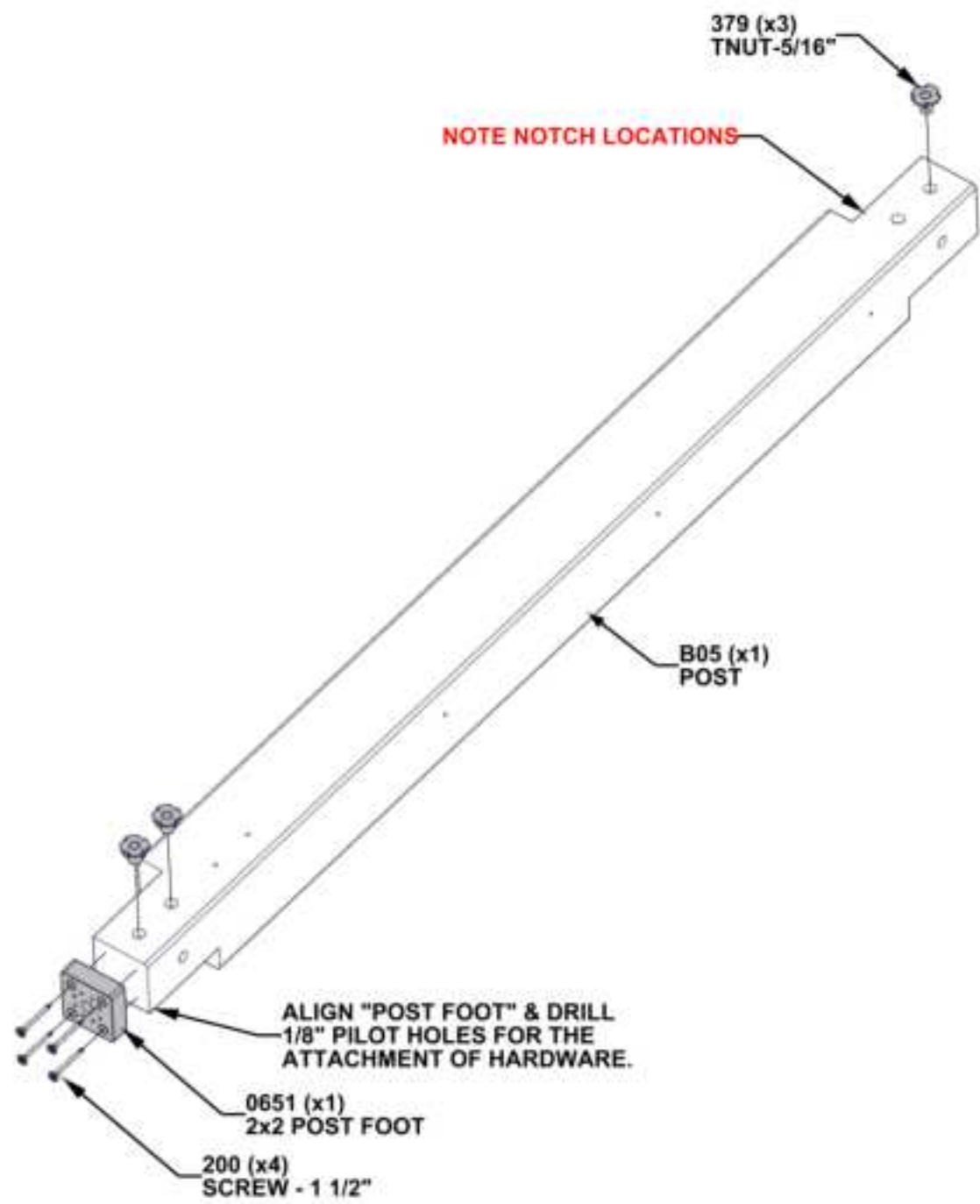

STEP 9 - B07 POST ASSEMBLY

QTY	PART NUMBER	DESCRIPTION
4	H100200	SCREW PFH 8x1 1/2 BLK



B07 POST - W4L22505
(x1) 3" x 3" x 40 5/16" (76x76x1024)



A6P00651 2x2 POST FOOT
(x1)

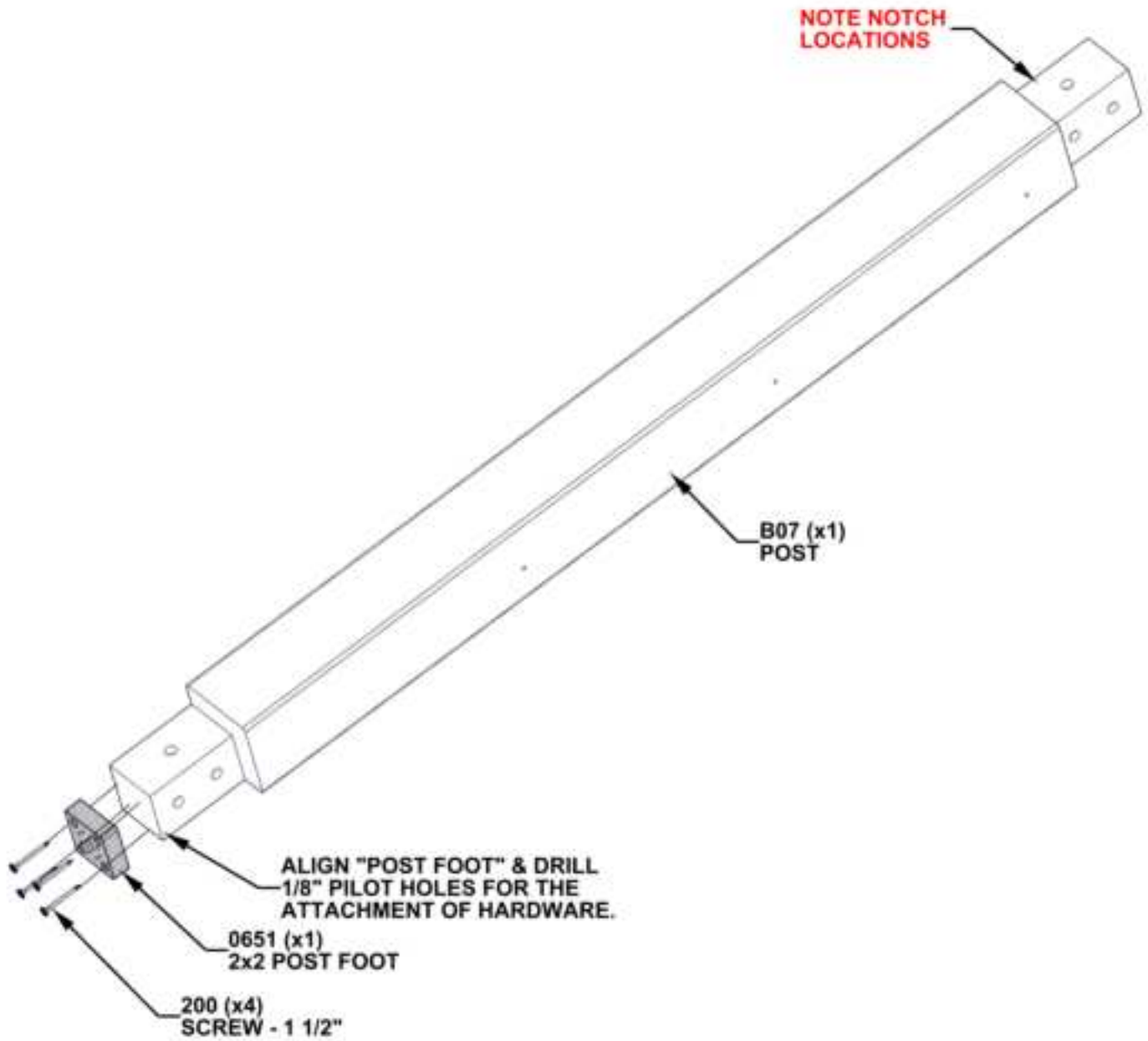

STEP 10 - B04 POST ASSEMBLY

QTY	PART NUMBER	DESCRIPTION
3	H100379	TNUT-5/16" BLK
4	H100200	SCREW PFH 8x1 1/2 BLK

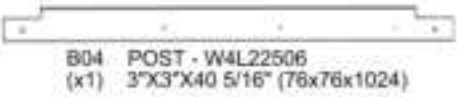

- INSTALL T-NUTS FIRST

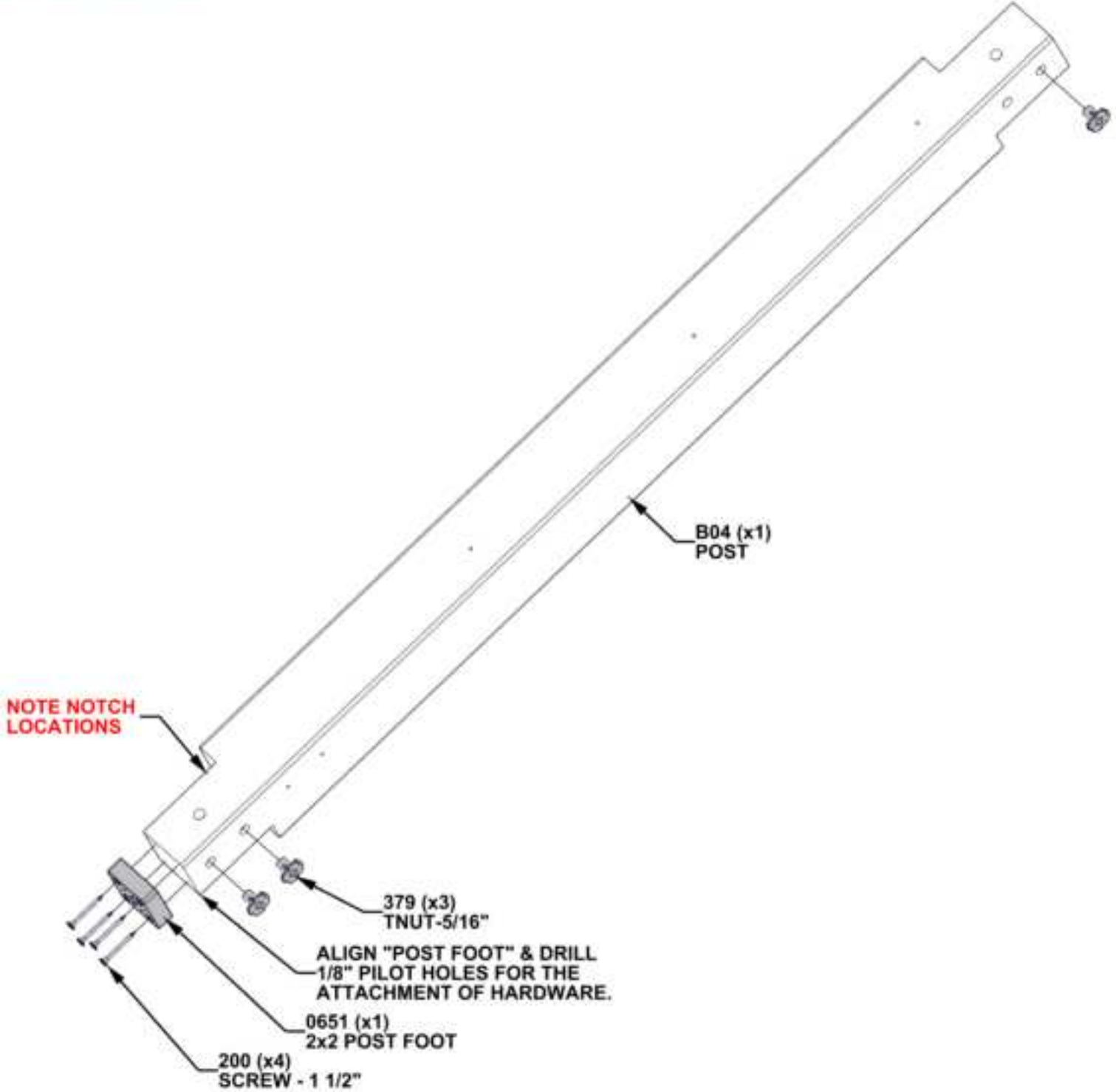

STEP 11 - ANIMAL ENCLOSURE ASSY

QTY	PART NUMBER	DESCRIPTION
3	H100415	BOLT WH 5/16x3 3/4 BLK
3	H100379	TNUT-5/16" BLK
1	H100198	WASHER LOCK EXT 8x19

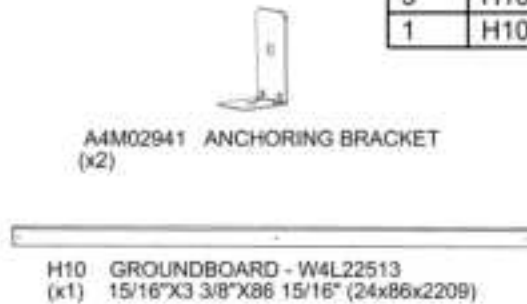
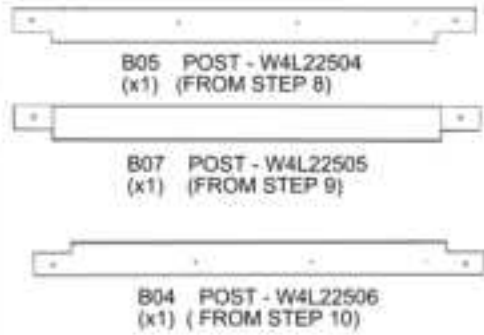

- INSTALL T-NUTS FIRST

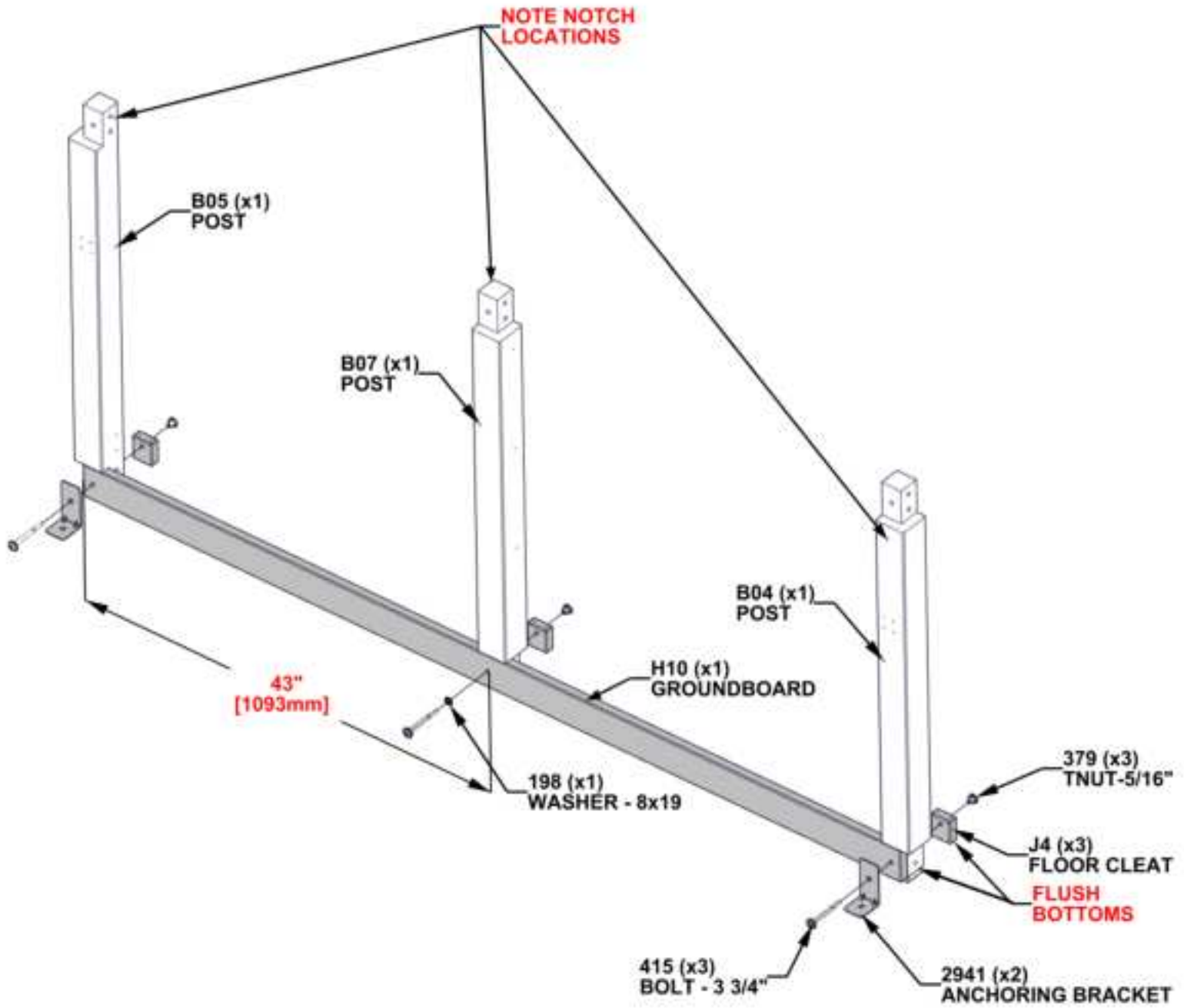

STEP 12 - ANIMAL ENCLOSURE ASSY

QTY	PART NUMBER	DESCRIPTION
6	H100379	TNUT-5/16" BLK
12	H100198	WASHER LOCK EXT 8x19
12	H100195	BOLT WH 5/16x2 3/4 BLK

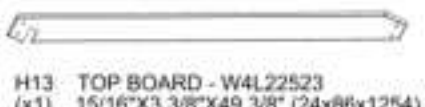
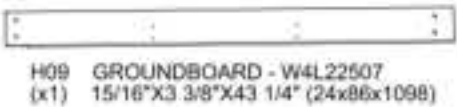

MIDDLE FRAME ASSEMBLY (x1) (FROM STEP 7)

BACK FRAME ASSEMBLY (x1) (FROM STEP 11)

- INSTALL T-NUTS FIRST

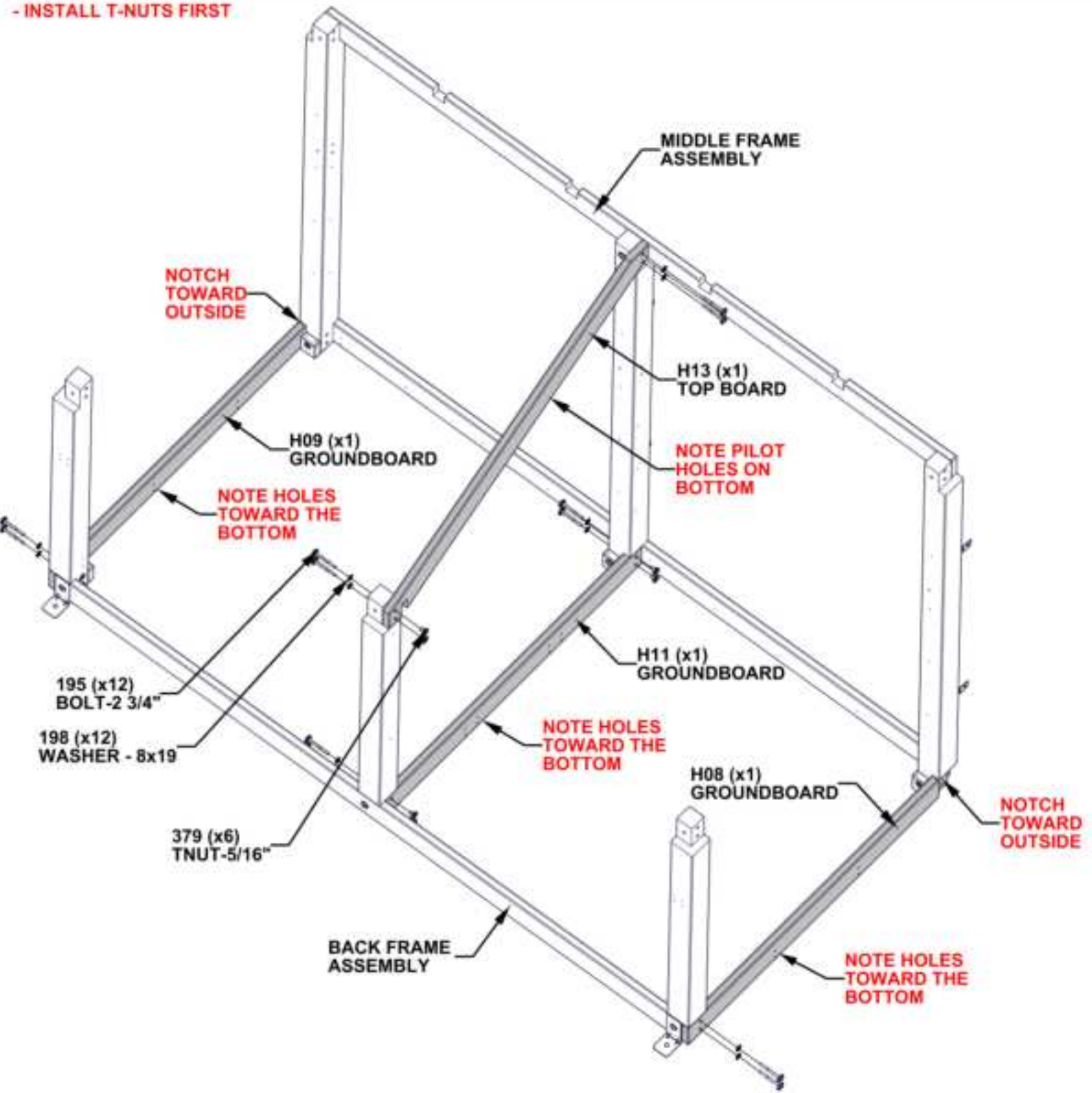

STEP 13A - ANIMAL ENCLOSURE ASSY

QTY	PART NUMBER	DESCRIPTION
4	H100198	WASHER LOCK EXT 8x19
4	H100195	BOLT WH 5/16x2 3/4 BLK



FRONT FRAME ASSEMBLY
(x1) (FROM STEP 3)



H03 GROUNDBOARD - W4L22508
(x1) 15/16"X3 3/8"X68 1/4" (24x86x1734)

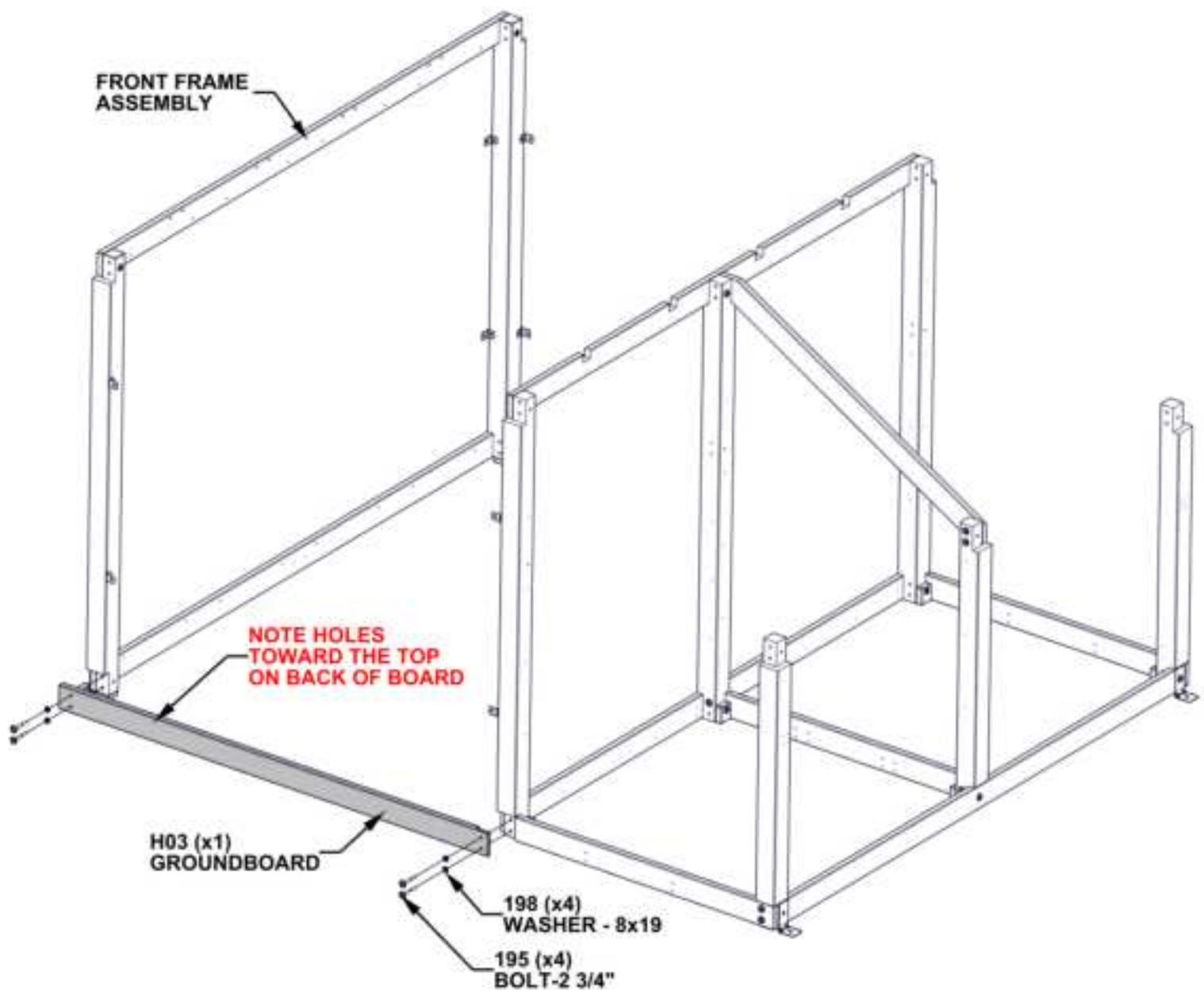

STEP 13B - ANIMAL ENCLOSURE ASSY

QTY	PART NUMBER	DESCRIPTION
4	H100198	WASHER LOCK EXT 8x19
4	H100195	BOLT WH 5/16x2 3/4 BLK

H07 GROUNDBOARD - W4L22510
(x1) 15/16"X3 3/8"X68 1/4" (24x86x1734)

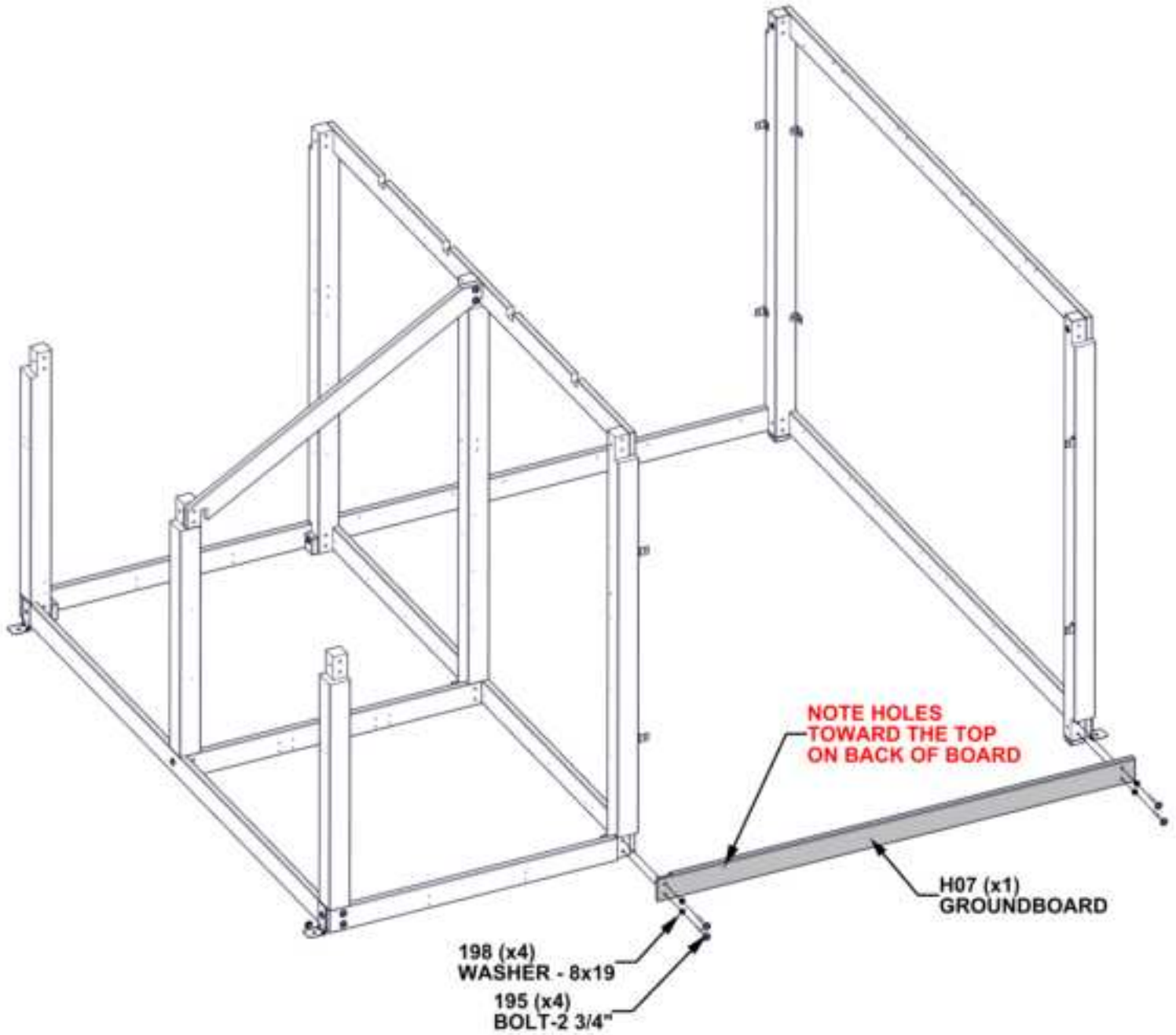

STEP 14A - ANIMAL ENCLOSURE ASSY

QTY	PART NUMBER	DESCRIPTION
3	H100379	TNUT-5/16" BLK
3	H100198	WASHER LOCK EXT 8x19
3	H100195	BOLT WH 5/16x2 3/4 BLK



H02 TOP BOARD - W4L22515
(x1) 15/16"X3 3/8"X68 1/4" (24x86x1734)



H06 TOP BOARD - W4L22518
(x1) 15/16"X3 3/8"X50 3/16" (24x86x1275)

- INSTALL T-NUTS FIRST

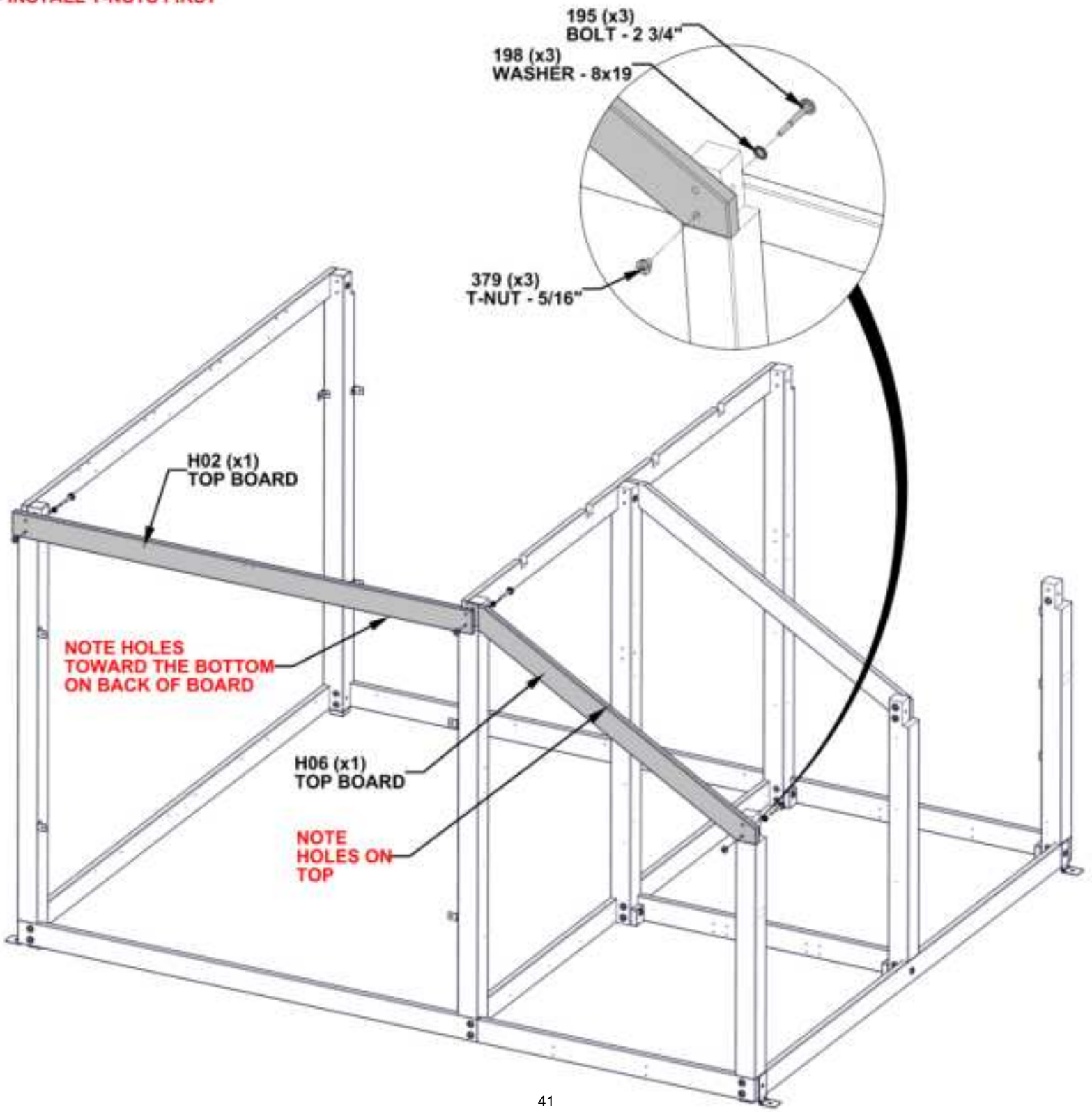

STEP 14B - ANIMAL ENCLOSURE ASSY

QTY	PART NUMBER	DESCRIPTION
3	H100379	TNUT-5/16" BLK
3	H100198	WASHER LOCK EXT 8x19
3	H100195	BOLT WH 5/16x2 3/4 BLK



H04 TOP BOARD - W4L22517
(x1) 15/16"X3 3/8"X58 1/4" (24x86x1734)



H05 TOP BOARD - W4L22519
(x1) 15/16"X3 3/8"X50 3/16" (24x86x1275)

**- INSTALL T-NUTS FIRST
- SQUARE**

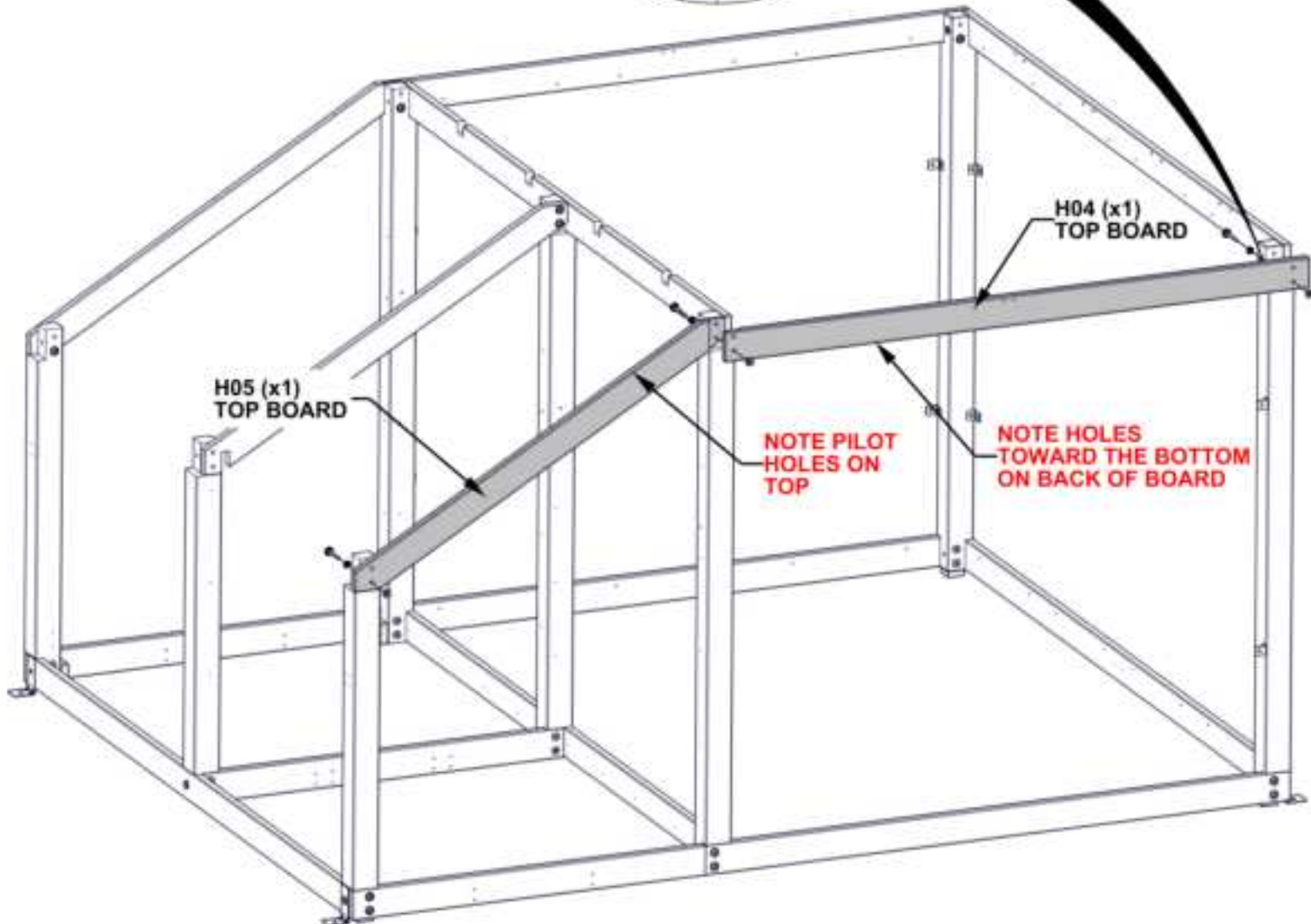
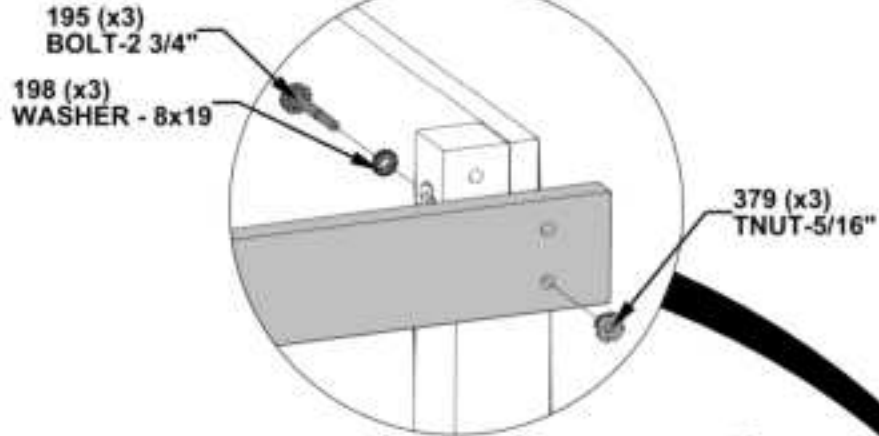

STEP 15 - ANIMAL ENCLOSURE ASSY

QTY	PART NUMBER	DESCRIPTION
4	H100653	NUT LOCK 1/4 BLK
4	H100630	WASHER FLAT 8x19 BLK
4	H100406	BOLT WH 1/4x1 1/2 BLK
8	H100392	SCREW PWH 8x3/4 BLK



H16 MIDDLE BOARD - W4L22555
(x2) 15/16"X3 3/8"X64 5/16" (24x88x1634)



A4M01785 ANGLE BRACKET
(x8)

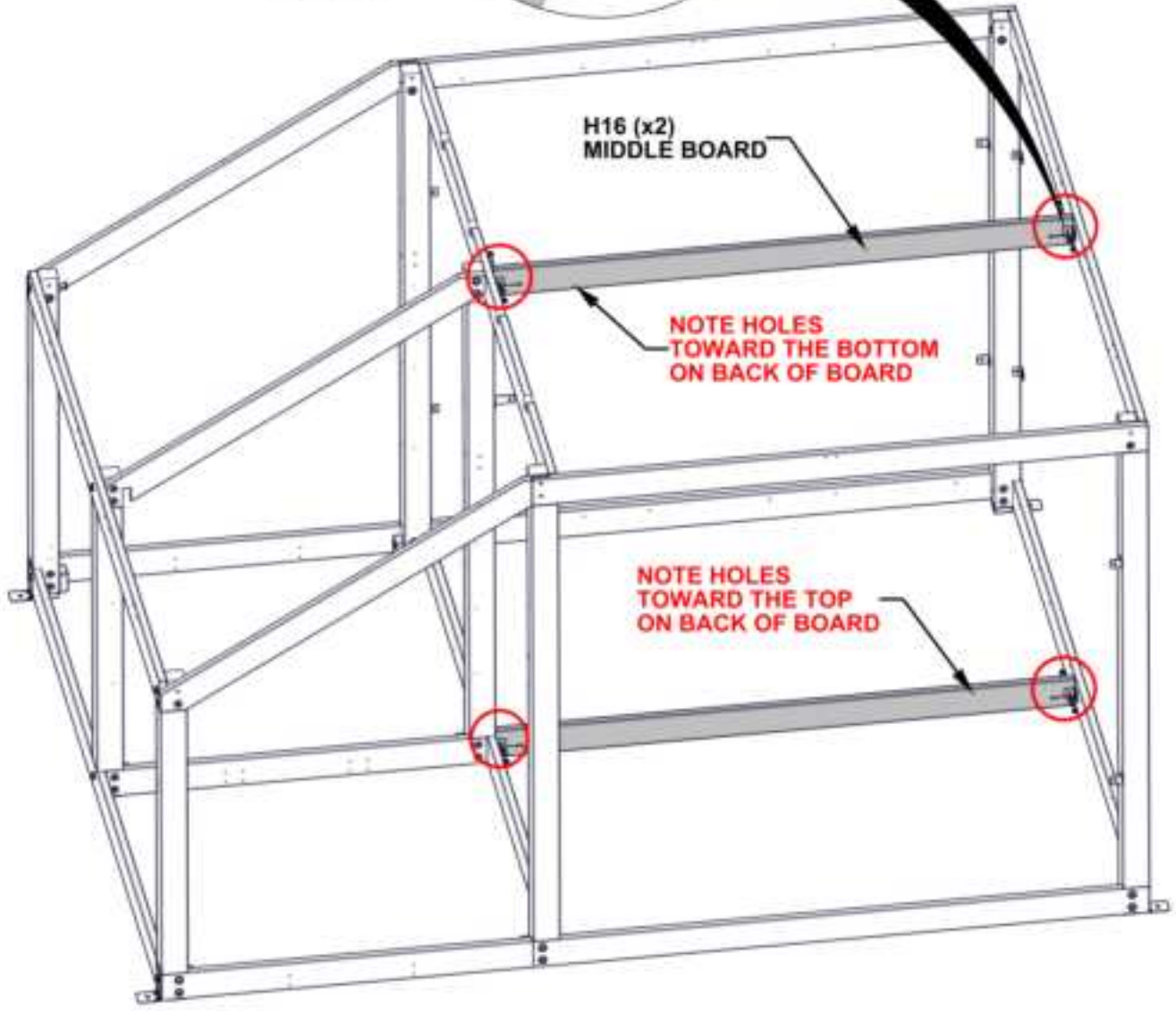
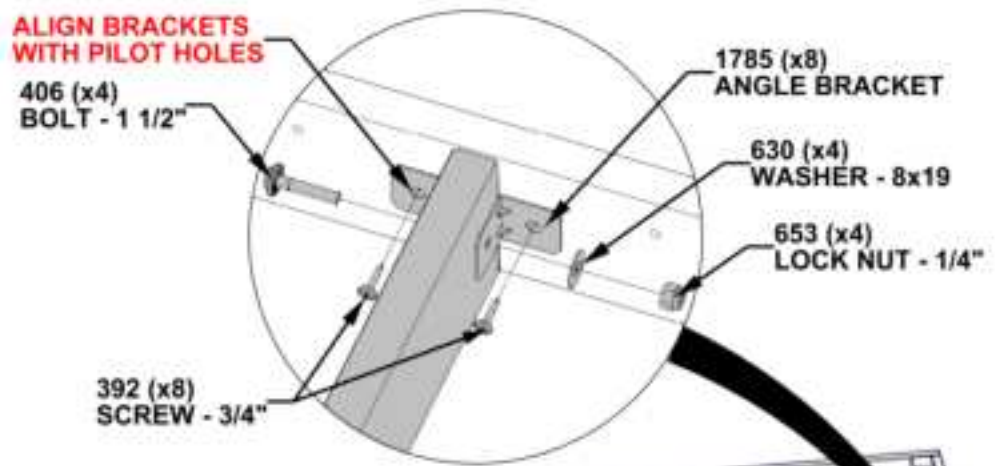

STEP 16 A- H18 ASSEMBLY

QTY	PART NUMBER	DESCRIPTION
4	H100392	SCREW PWH 8x3/4 BLK



H18 TOP BOARD - W4L22521
(x1) 15/16"X3 3/8"X86 15/16" (24x86x2209)



A4M00997 METAL CLEAT
(x2)

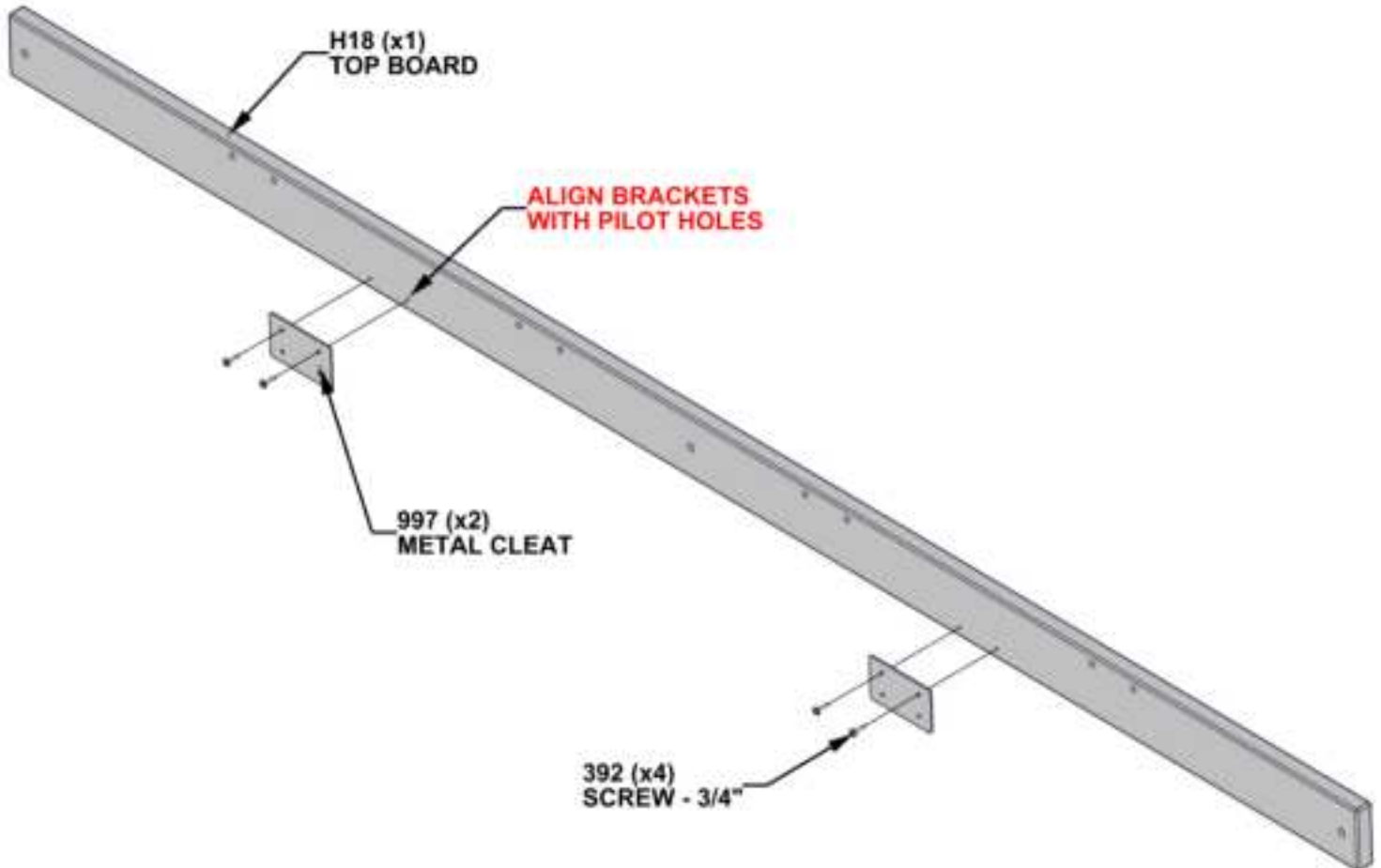

STEP 16 B - ANIMAL ENCLOSURE ASSY

QTY	PART NUMBER	DESCRIPTION
3	H100415	BOLT WH 5/16x3 3/4 BLK
3	H100379	TNUT-5/16" BLK
3	H100198	WASHER LOCK EXT 8x19



H18 BOARD ASSEMBLY
(x1) (FROM STEP 15A)



J13 FLOOR JOIST - W4L22550
(x1) 15/16"X2 3/8"X44 1/2" (24x60x1131)

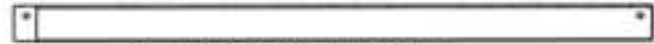

J5 FLOOR JOIST - W4L22543
(x1) 15/16"X2 3/8"X43 11/16" (24x60x1110)

- INSTALL T-NUTS FIRST

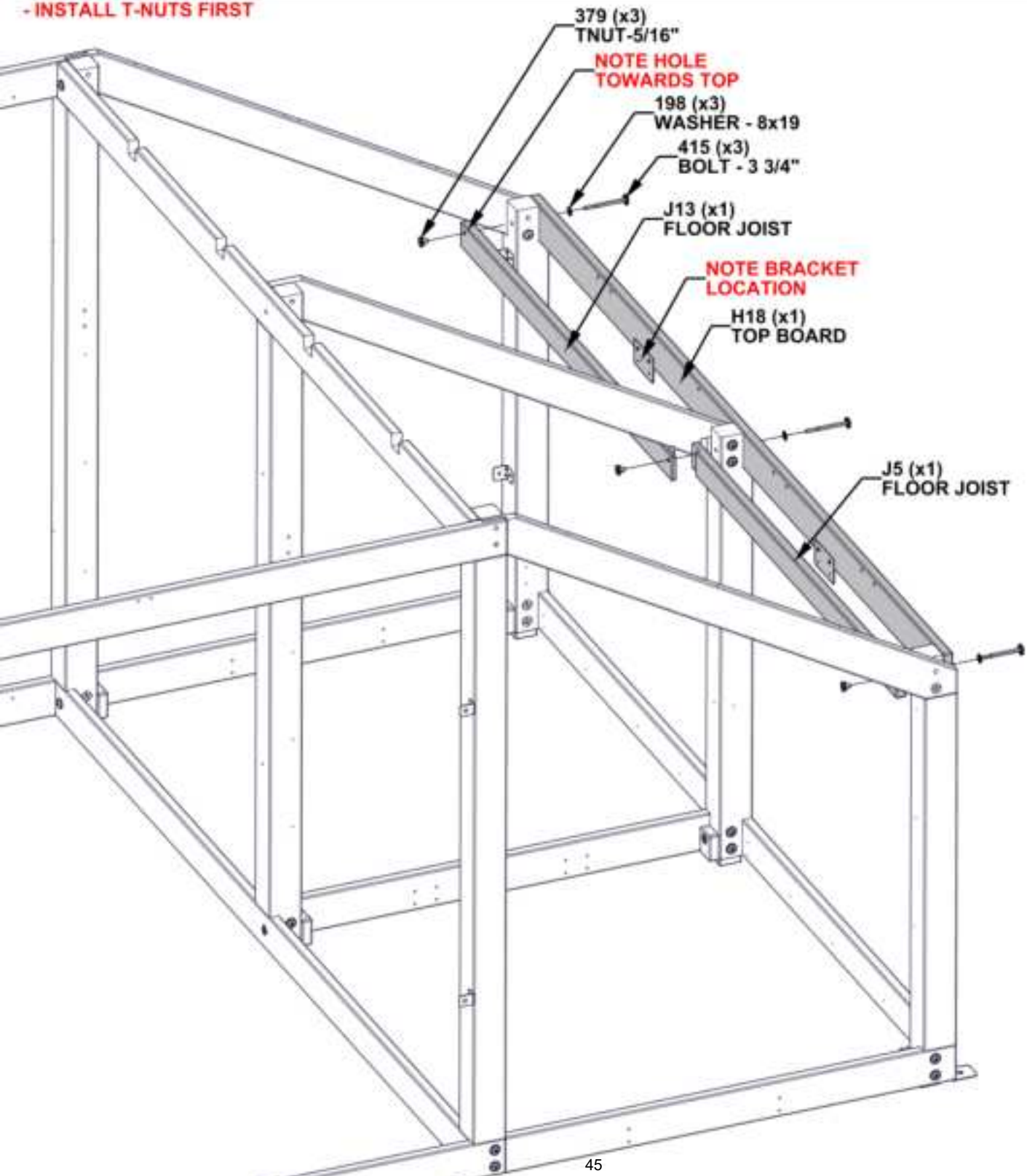

STEP 17 - ANIMAL ENCLOSURE ASSY

QTY	PART NUMBER	DESCRIPTION
28	H100200	SCREW PFH 8x1 1/2 BLK



J1 FLOOR JOIST - W4L22537
(x4) 15/16"X2 3/8"X39 11/16" (24x60x1009)

- ALIGN BOARDS WITH PILOT HOLES

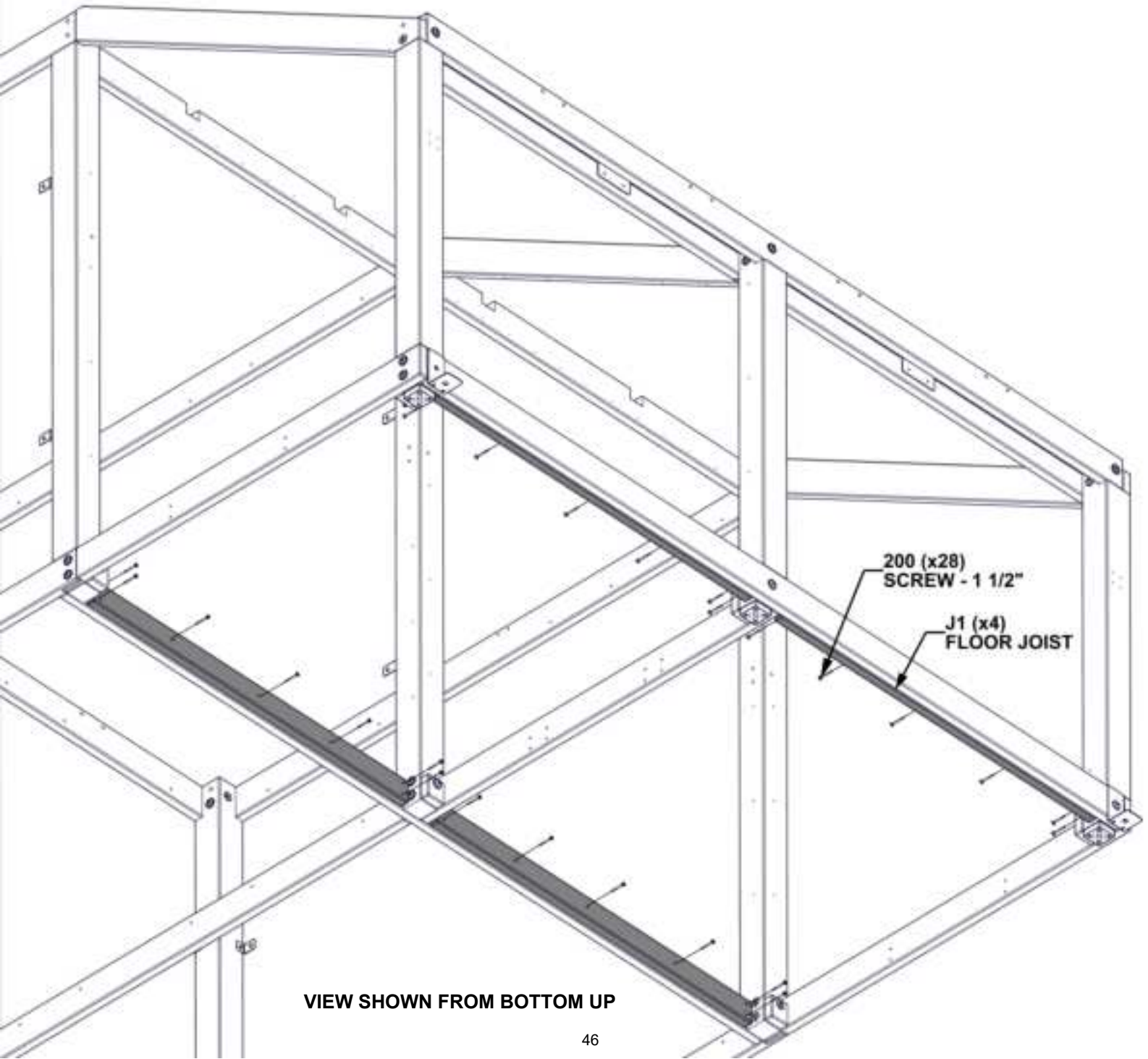

VIEW SHOWN FROM BOTTOM UP

STEP 18A - ANIMAL ENCLOSURE ASSY

QTY	PART NUMBER	DESCRIPTION
8	H100391	SCREW PFH 8x2 BLK



J7 FLOOR JOIST -W4L22540
(x2) 15/16"X2 3/8"X41 7/8" (24x60x1063)

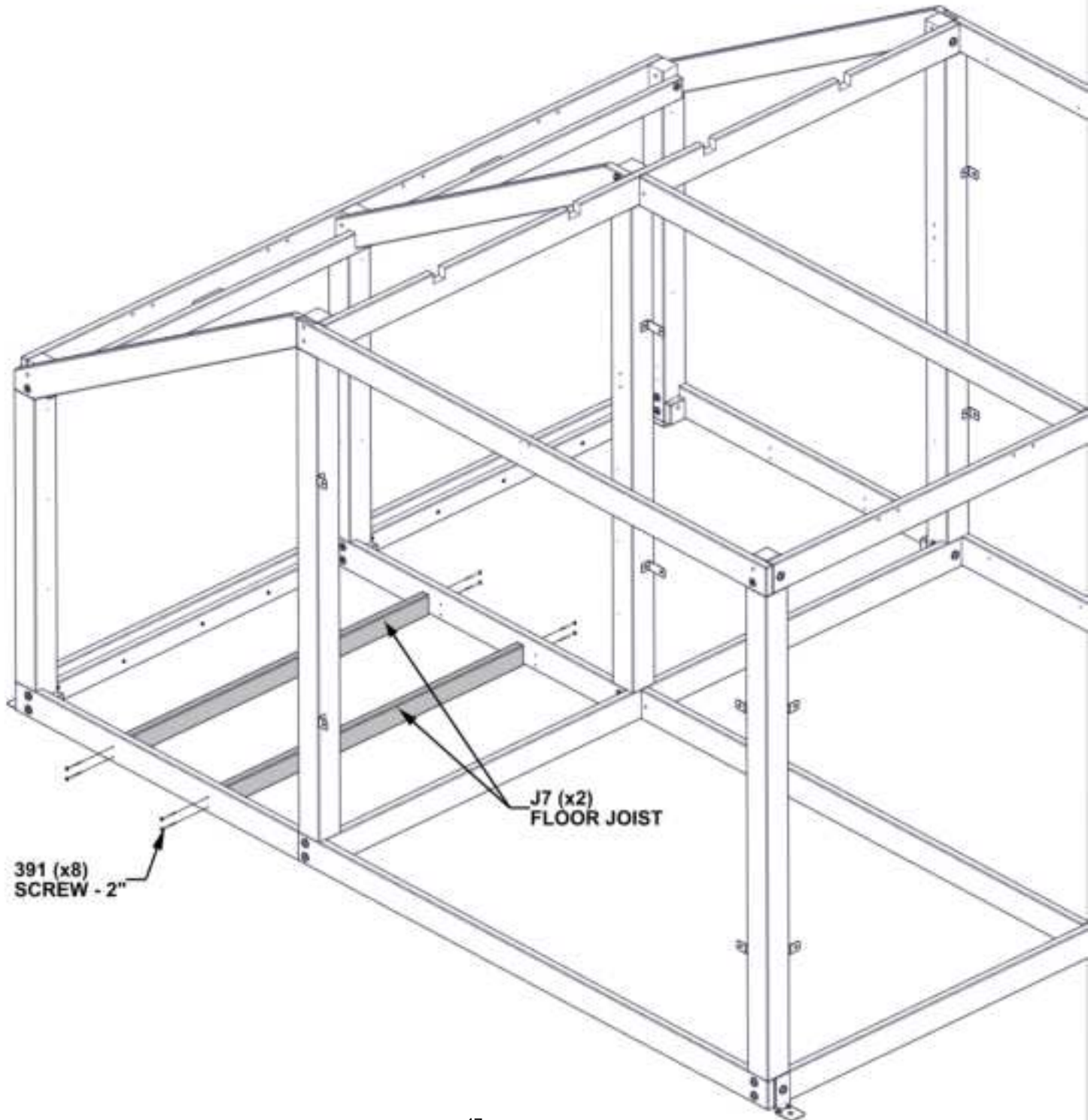

STEP 18B - ANIMAL ENCLOSURE ASSY

QTY	PART NUMBER	DESCRIPTION
8	H100391	SCREW PFH 8x2 BLK



J2 FLOOR JOIST - W4L22538
(x2) 15/16"X2 3/8"X44" (24x60x1118)

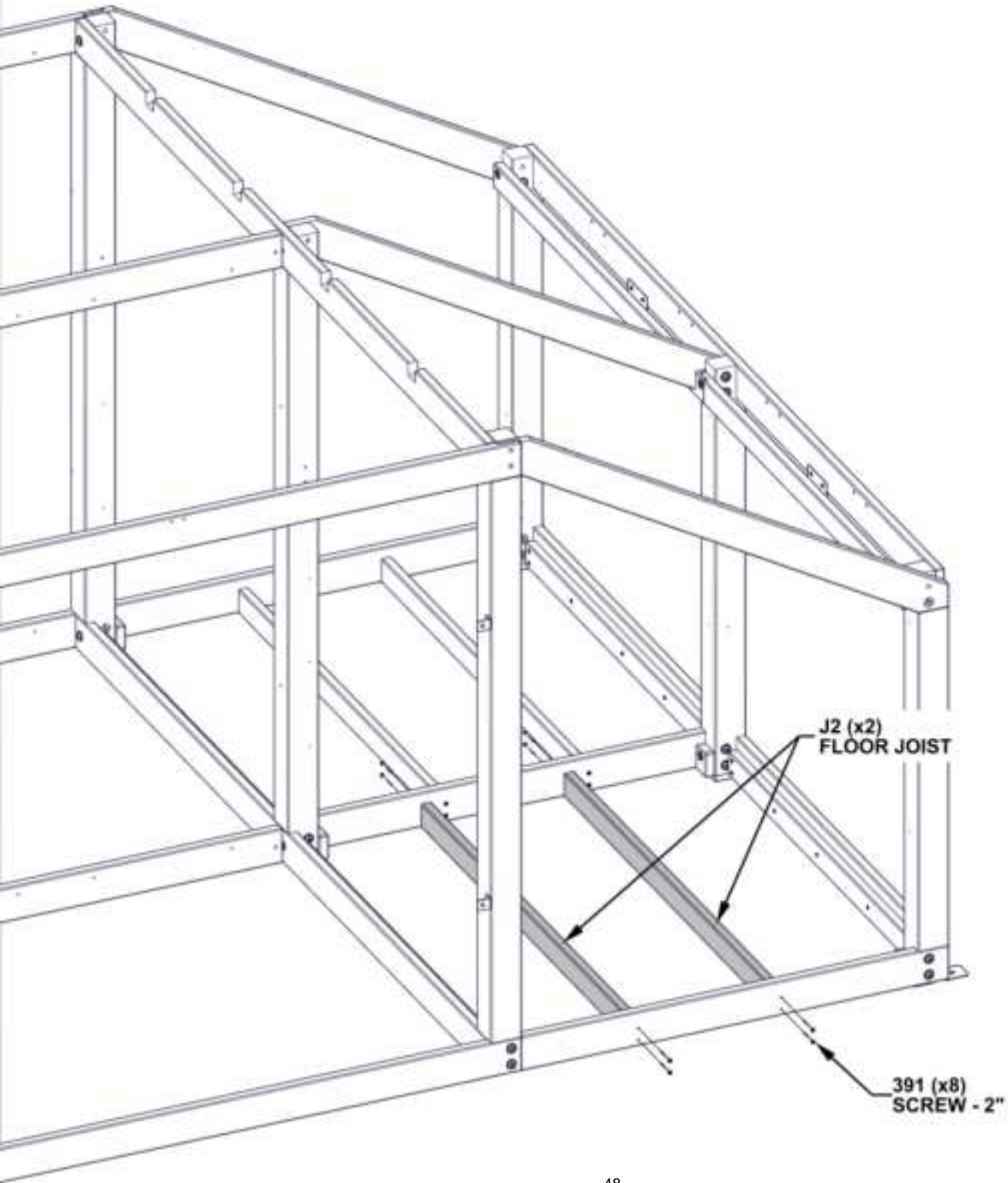

STEP 19 - ANIMAL ENCLOSURE ASSY

QTY	PART NUMBER	DESCRIPTION
84	H100391	SCREW PFH 8x2 BLK



H14 FLOOR BOARD - W4L22539
(x10) 15/16"X3 3/8"X42 3/16" (24x86x1072)



J11 FLOOR BOARD - W4L22541
(x1) 15/16"X2 13/16"X42 3/16" (24x71x1072)



J3 FLOOR BOARD - W4L22535
(x2) 15/16"X2 1/16"X38 1/8" (24x52x968)



J15 FLOOR BOARD - W4L23456
(x1) 15/16"X2 13/16"X42 3/16" (24x71x1072)

- SPACE BOARDS EVENLY

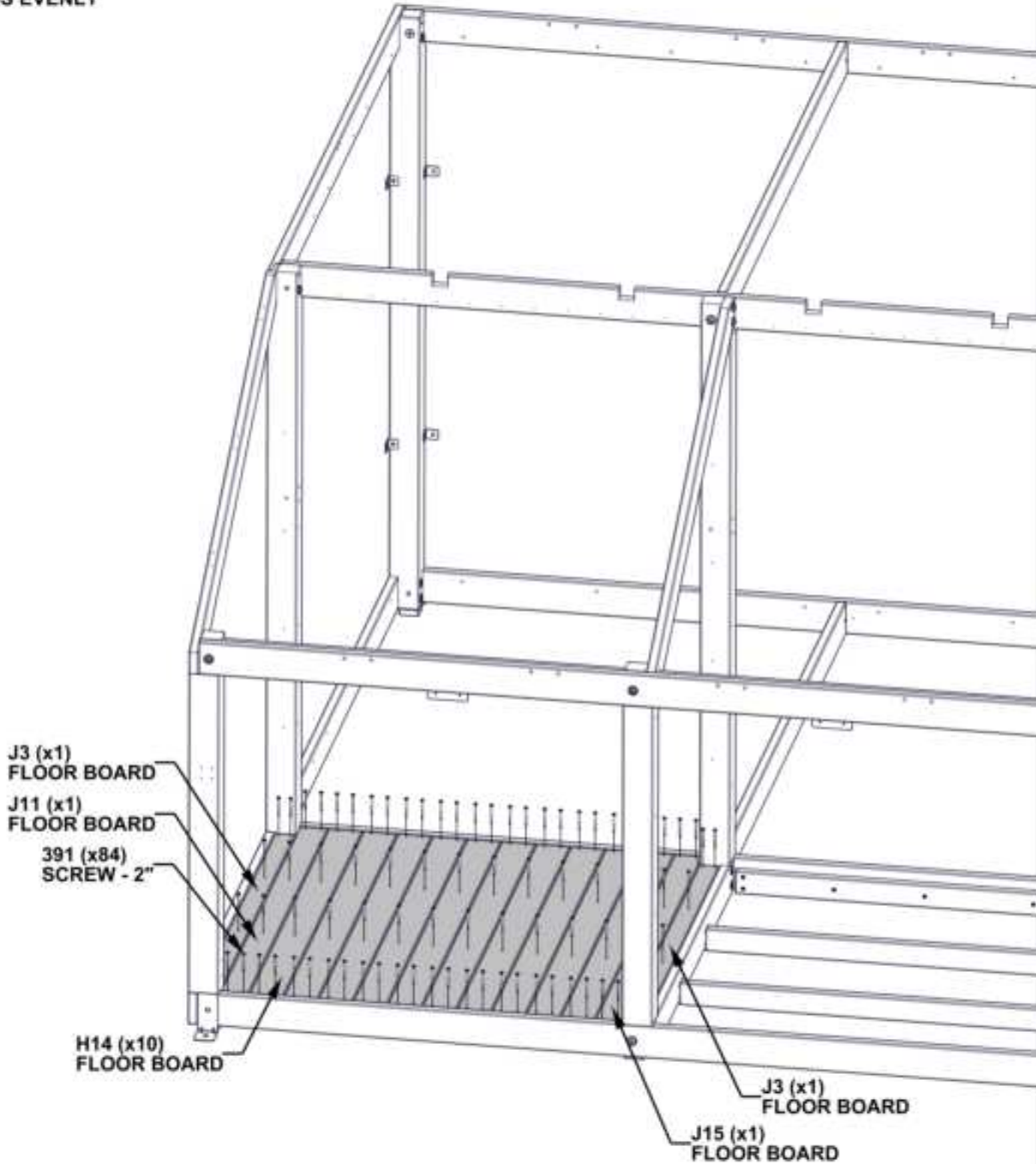

STEP 20 - ANIMAL ENCLOSURE ASSY

QTY	PART NUMBER	DESCRIPTION
78	H100391	SCREW PFH 8x2 BLK

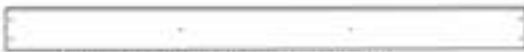

H14 FLOOR BOARD - W4L22539
(x10) 15/16"X3 3/8"X42 3/16" (24x86x1072)



J11 FLOOR BOARD - W4L22541
(x2) 15/16"X2 13/16"X42 3/16" (24x71x1072)



J3 FLOOR BOARD - W4L22535
(x1) 15/16"X2 1/16"X38 1/8" (24x52x968)

- SPACE BOARDS EVENLY

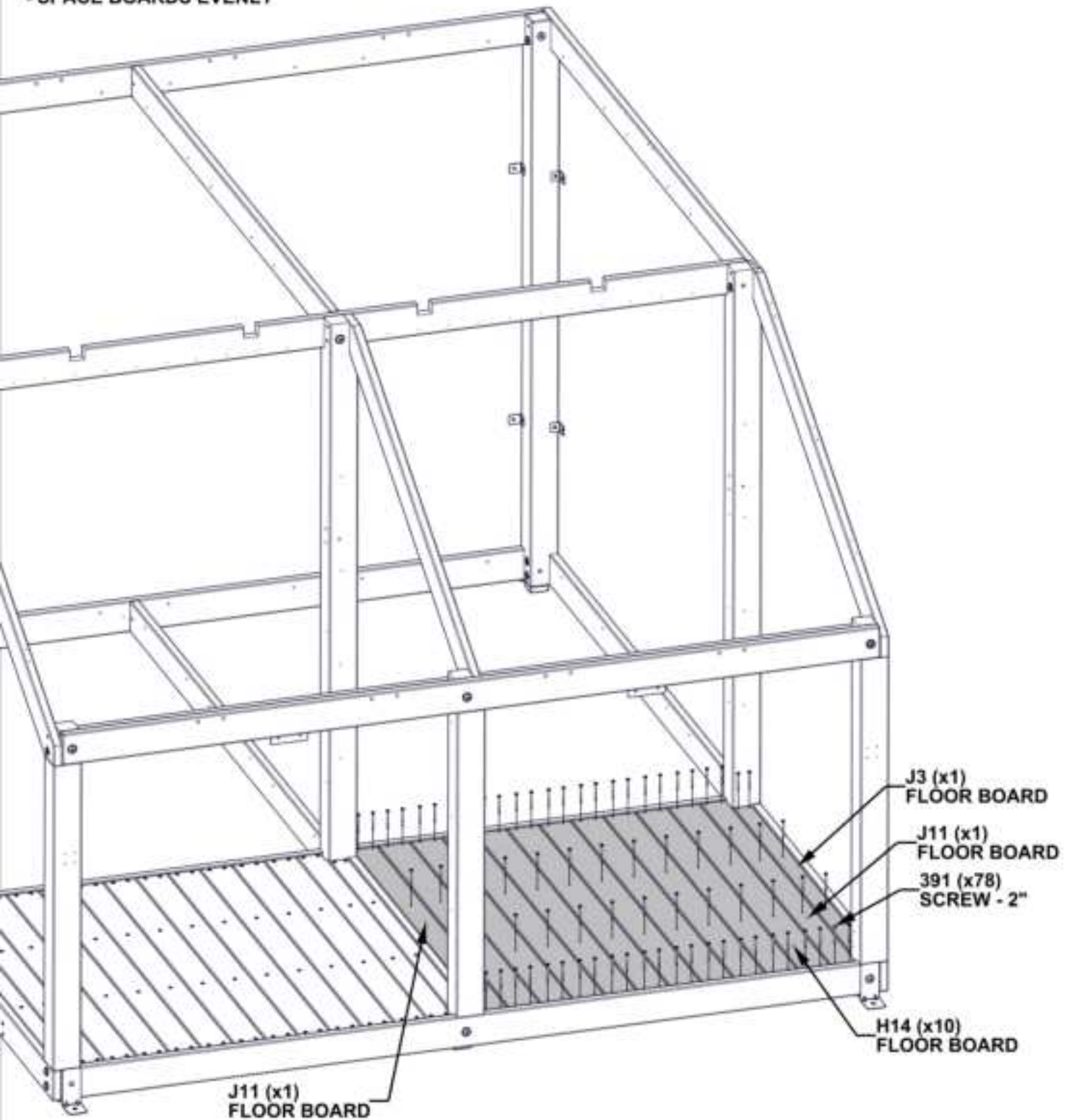

STEP 21 A - WP6 ASSEMBLY

QTY	PART NUMBER	DESCRIPTION
5	H100392	SCREW PWH 8x3/4 BLK



WP6 WALL PANEL - W2A04945
(x1) 1 1/16"X19 1/16"X44 9/16" (27x484x1133)



A4M01785 ANGLE BRACKET
(x5)

- ALIGN BRACKETS WITH PILOT HOLES
- SQUARE BRACKETS BEFORE ATTACHING SCREWS

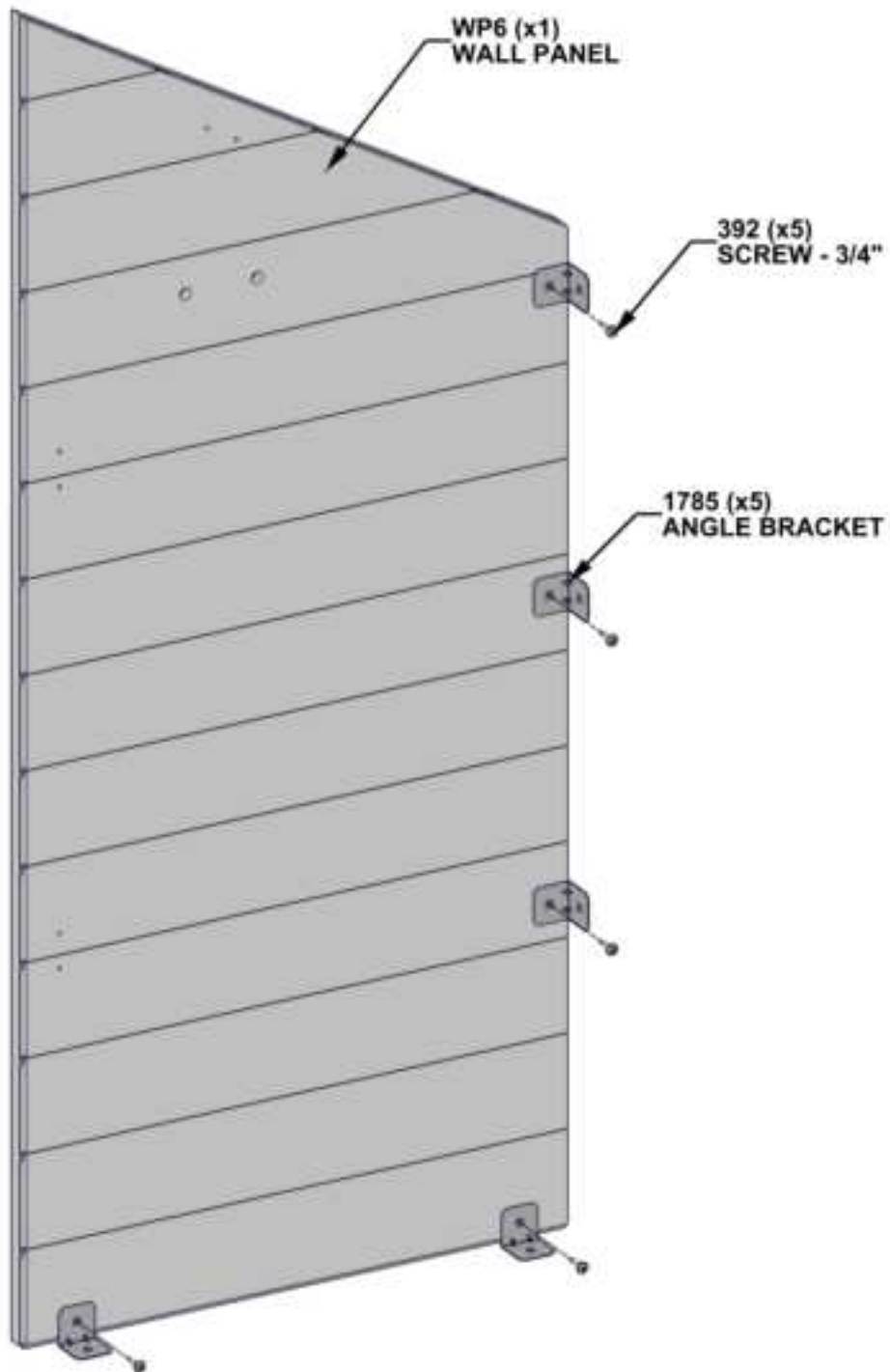

STEP 21 B - WP5 ASSEMBLY

QTY	PART NUMBER	DESCRIPTION
6	H100392	SCREW PWH 8x3/4 BLK



WP5 WALL PANEL - W2A04944
(x1) 1 1/16"X19 1/16"X55 5/8" (27x484x1412)



A4M01785 ANGLE BRACKET
(x6)

- ALIGN BRACKETS WITH PILOT HOLES
- SQUARE BRACKETS BEFORE ATTACHING SCREWS

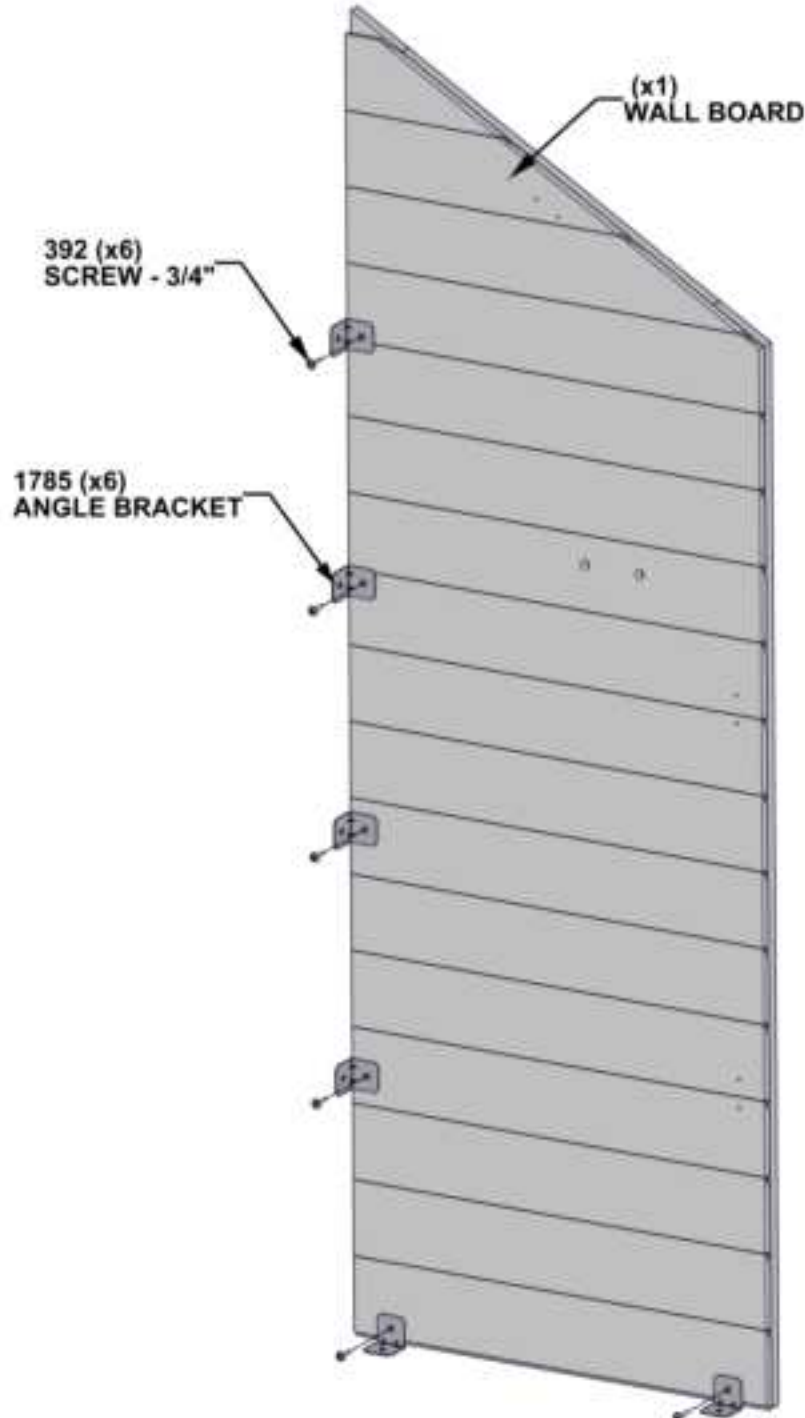

STEP 21 C - WP5 & WP6 ASSEMBLY

QTY	PART NUMBER	DESCRIPTION
12	H100392	SCREW PWH 8x3/4 BLK



WP6 ASSEMBLY
(x1) (FROM STEP 21 A)

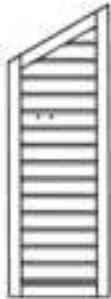

WP5 ASSEMBLY
(x1) (FROM STEP 21 B)

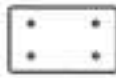

A4M00997 METAL CLEAT
(x4)

- ALIGN BRACKETS WITH PILOT HOLES
- SQUARE BRACKETS BEFORE ATTACHING SCREWS

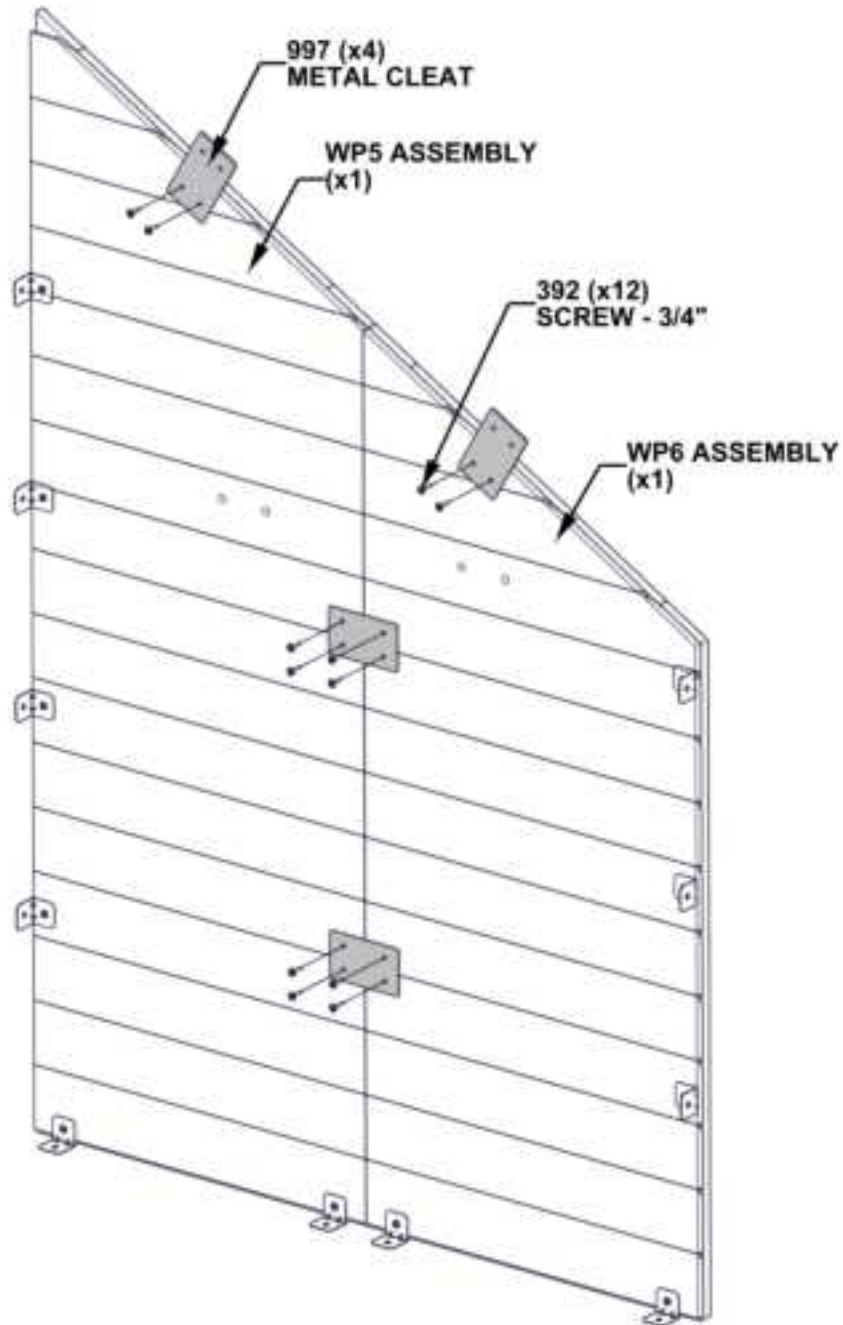

STEP 21D - ANIMAL ENCLOSURE ASSY

QTY	PART NUMBER	DESCRIPTION
7	H100797	SCREW PWH 8x1 BLK
8	H100392	SCREW PWH 8x3/4 BLK



- PREDRILL 1/8" [3mm] PILOT HOLES FOR THE ATTACHMENT OF HARDWARE INTO BRACKETS.
- USE PILOT HOLES TO ALIGN SCREWS.

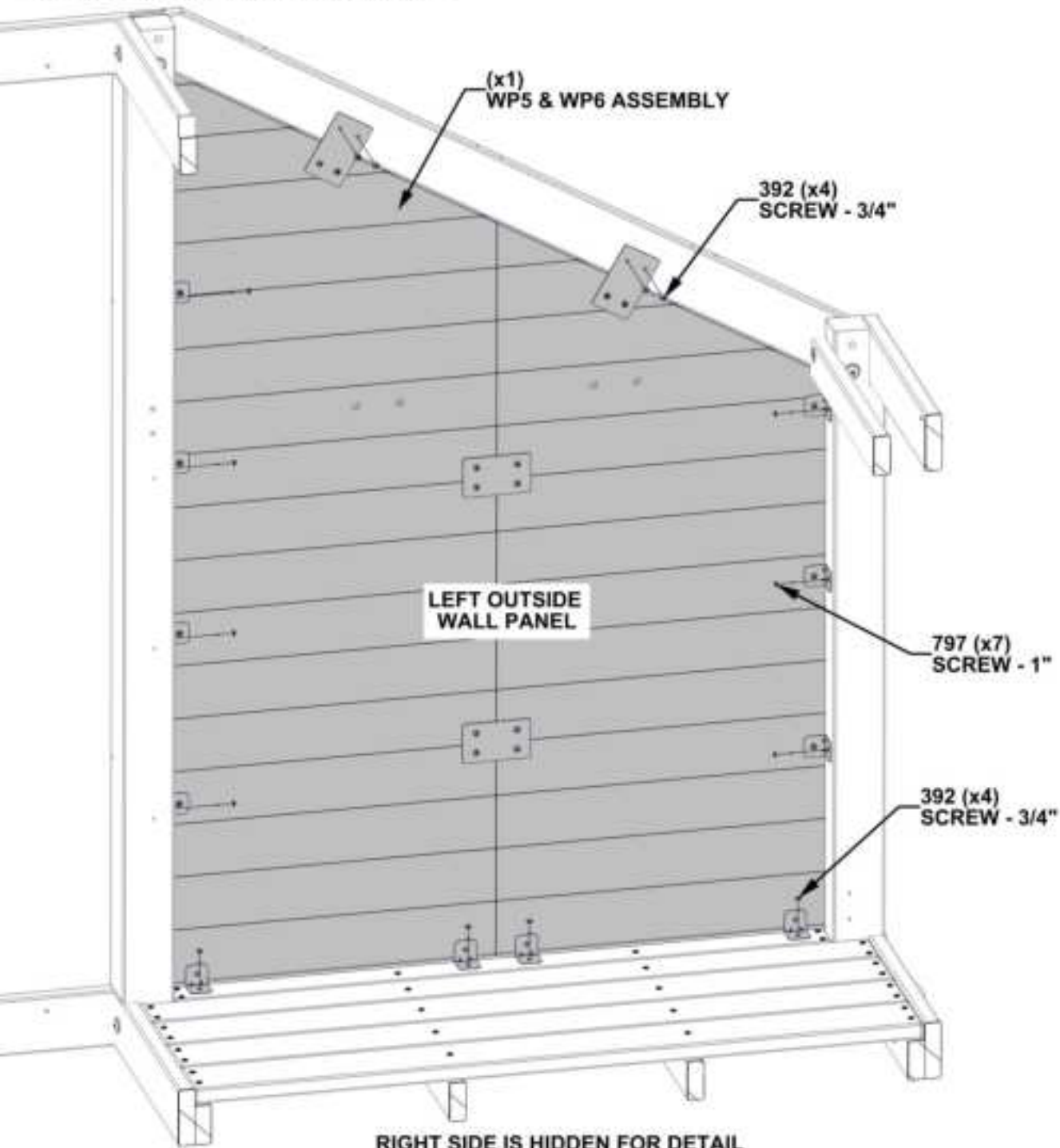

STEP 22 A - WP11 ASSEMBLY

QTY	PART NUMBER	DESCRIPTION
5	H100392	SCREW PWH 8x3/4 BLK



WP11 WALL PANEL - W2A04953
(x1) 1 1/16"X19 1/16"X44 9/16" (27x484x1133)



A4M01785 ANGLE BRACKET
(x5)

- ALIGN BRACKETS WITH PILOT HOLES
- SQUARE BRACKETS BEFORE ATTACHING SCREWS

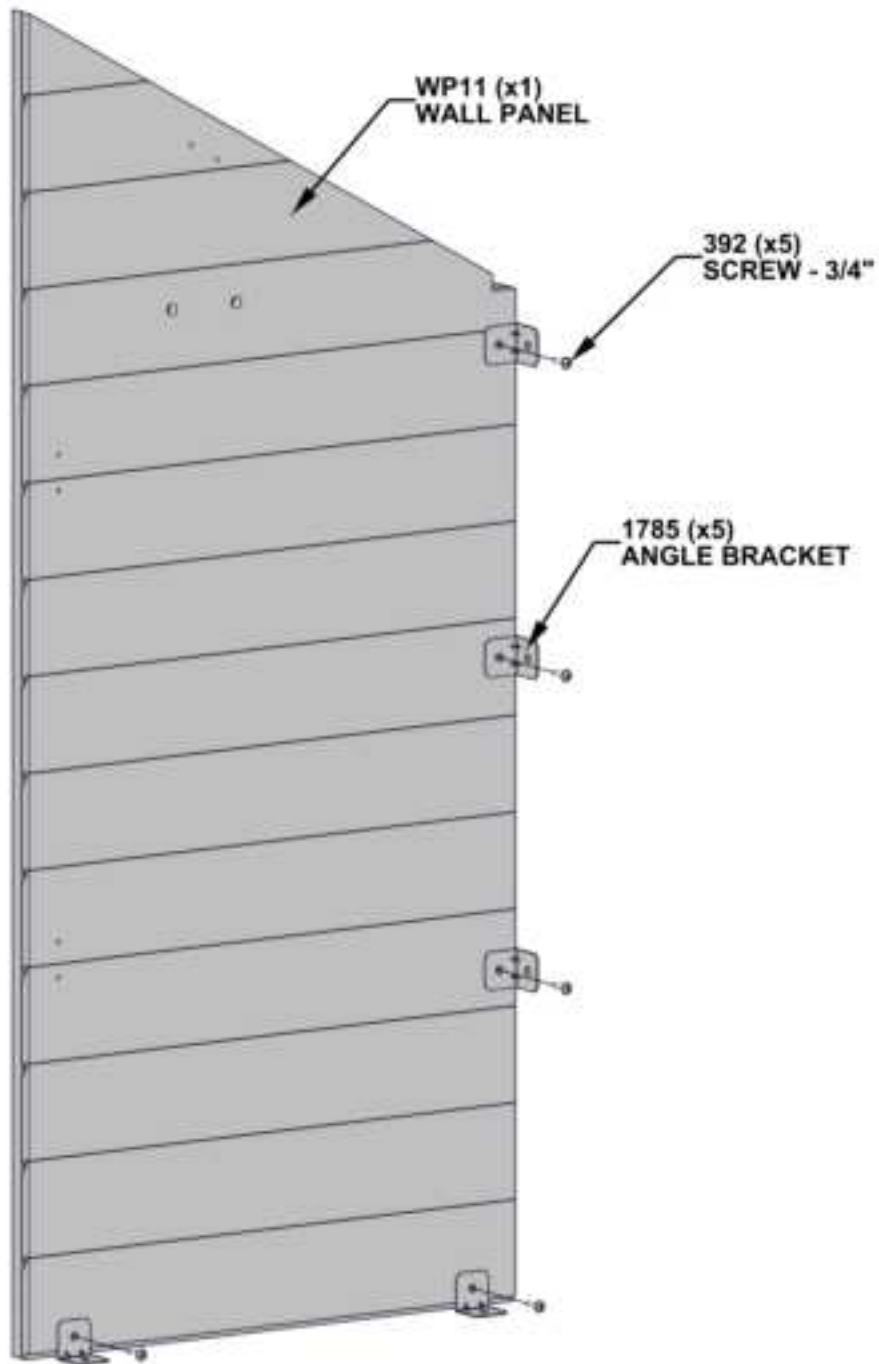

STEP 22 B - WP12 ASSEMBLY

QTY	PART NUMBER	DESCRIPTION
6	H100392	SCREW PWH 8x3/4 BLK



WP12 WALL PANEL - W2A04954
(x1) 1 1/16"X19 1/16"X55 5/8" (27x484x1412)



A4M01785 ANGLE BRACKET
(x6)

- ALIGN BRACKETS WITH PILOT HOLES
- SQUARE BRACKETS BEFORE ATTACHING SCREWS

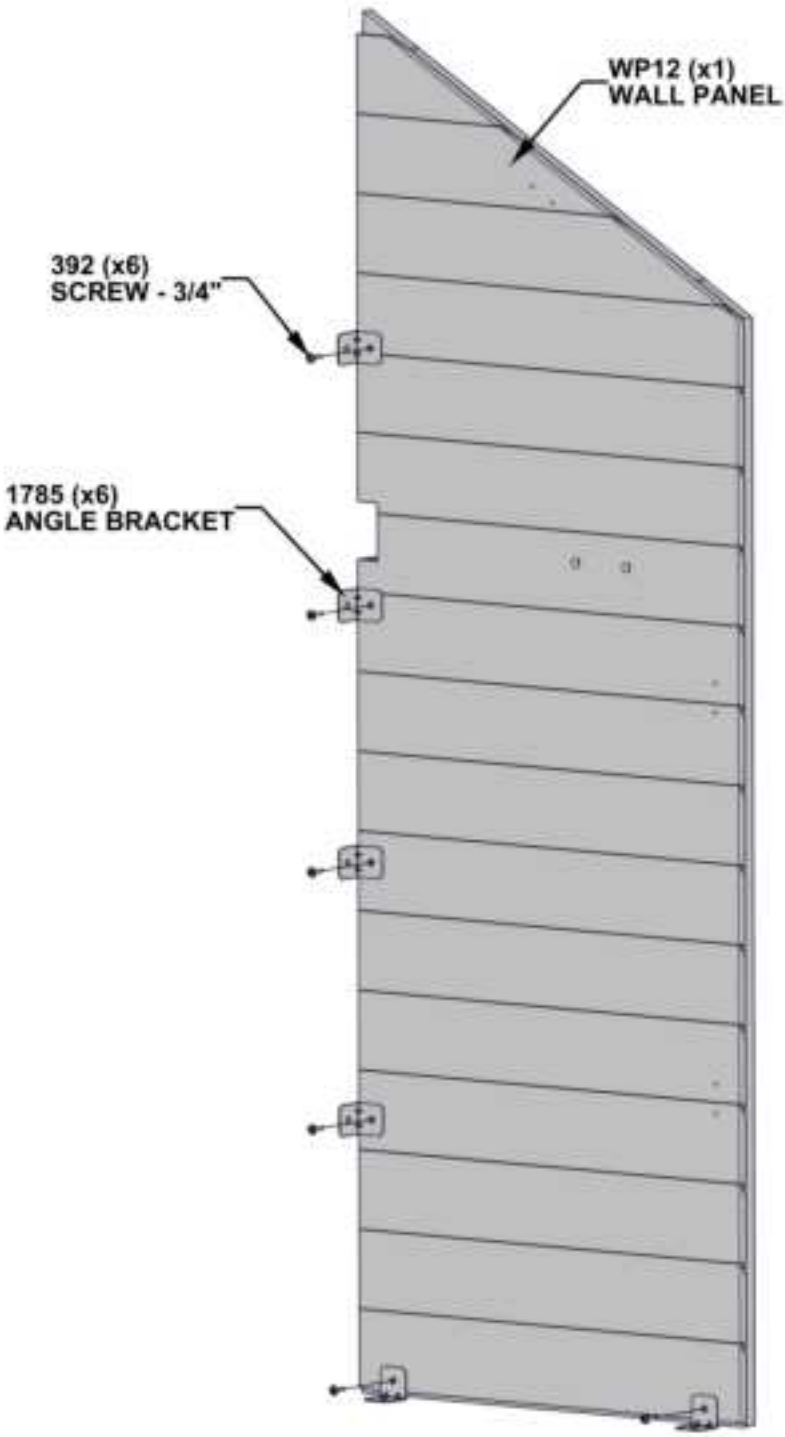

STEP 22 C- WP11 & WP12 ASSEMBLY

QTY	PART NUMBER	DESCRIPTION
12	H100392	SCREW PWH 8x3/4 BLK



WP11 ASSEMBLY
(x1) (FROM STEP 22A)



WP12 ASSEMBLY
(x1) (FROM STEP 22B)



A4M00997 METAL CLEAT
(x4)

- ALIGN BRACKETS WITH PILOT HOLES
- SQUARE BRACKETS BEFORE ATTACHING SCREWS

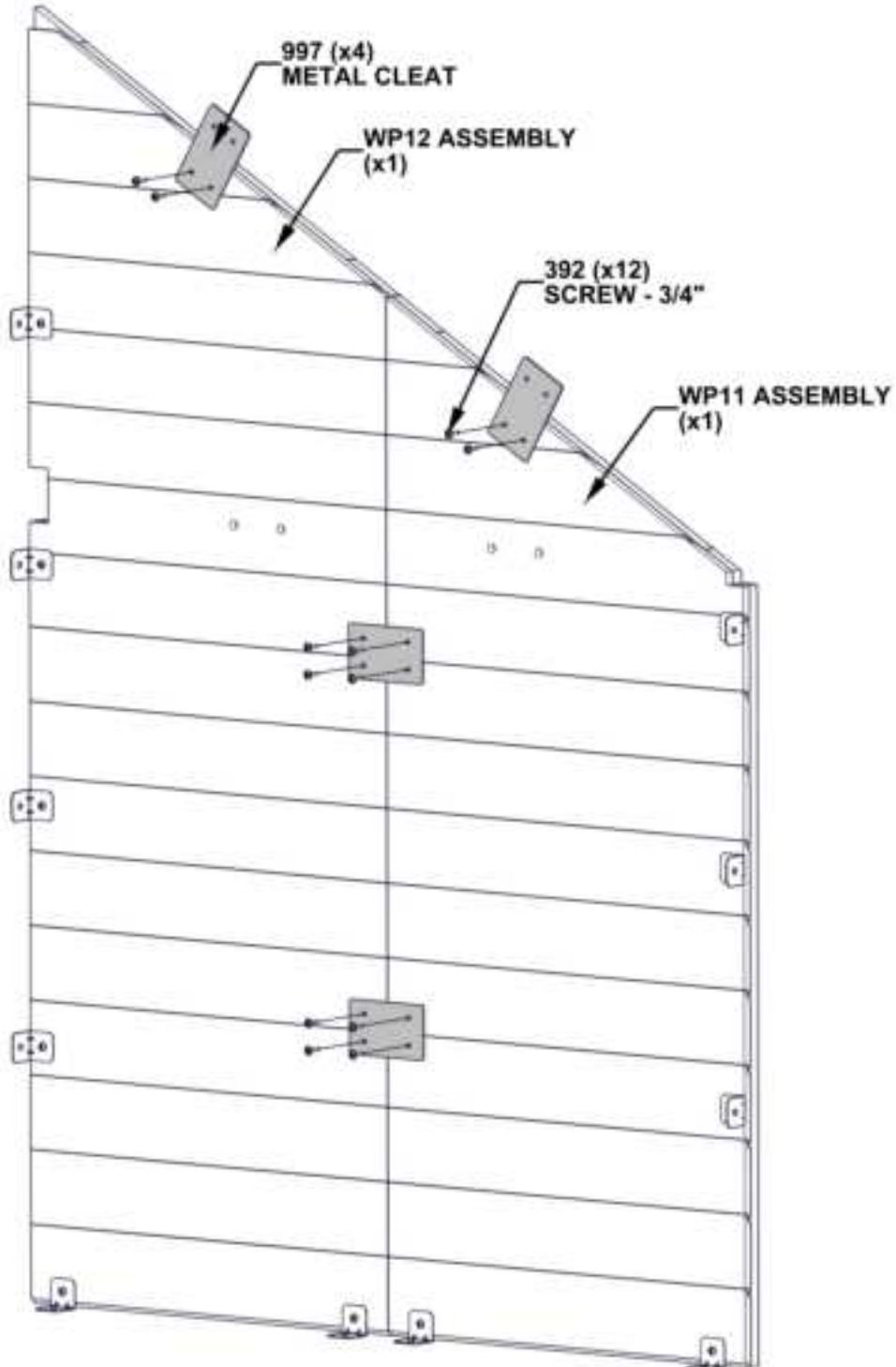

STEP 22D - ANIMAL ENCLOSURE ASSY

QTY	PART NUMBER	DESCRIPTION
7	H100797	SCREW PWH 8x1 BLK
8	H100392	SCREW PWH 8x3/4 BLK

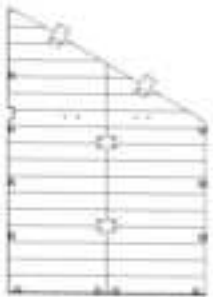

WP11 & WP12 ASSEMBLY
(x1) (FROM STEPS 22C)

- PREDRILL 1/8" [3mm] PILOT HOLES FOR THE ATTACHMENT OF HARDWARE INTO BRACKETS.
- USE PILOT HOLES TO ALIGN SCREWS.

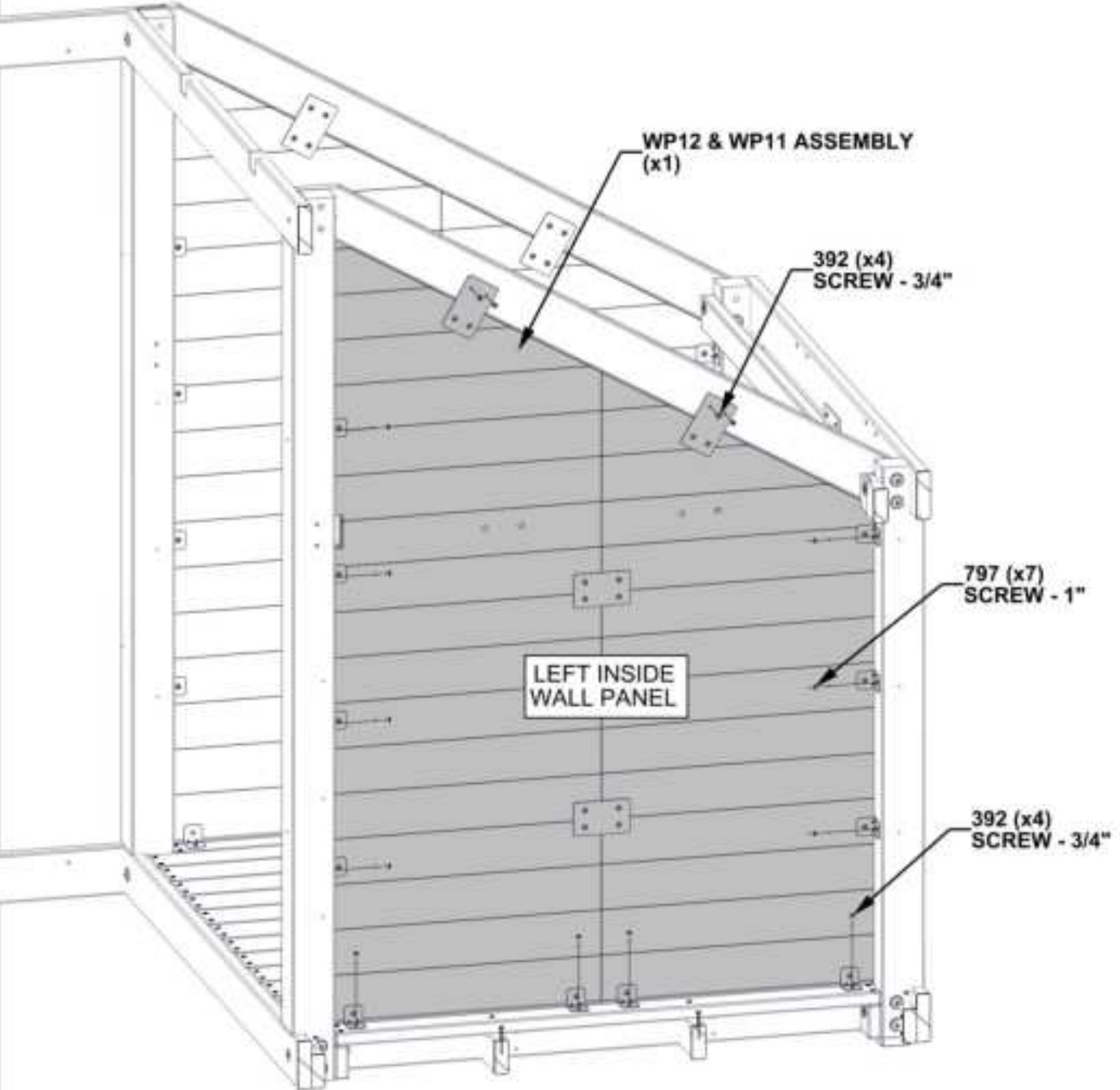

RIGHT SIDE IS HIDDEN FOR DETAIL

STEP 23A - WP4 ASSEMBLY

QTY	PART NUMBER	DESCRIPTION
5	H100392	SCREW PWH 8x3/4 BLK

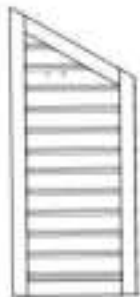

WP4 WALL PANEL - W2A04943
(x1) 1 1/8"X19 1/16"X44 9/16" (27X484X1133)



A4M01785 ANGLE BRACKET
(x5)

- ALIGN BRACKETS WITH PILOT HOLES
- SQUARE BRACKETS BEFORE ATTACHING SCREWS

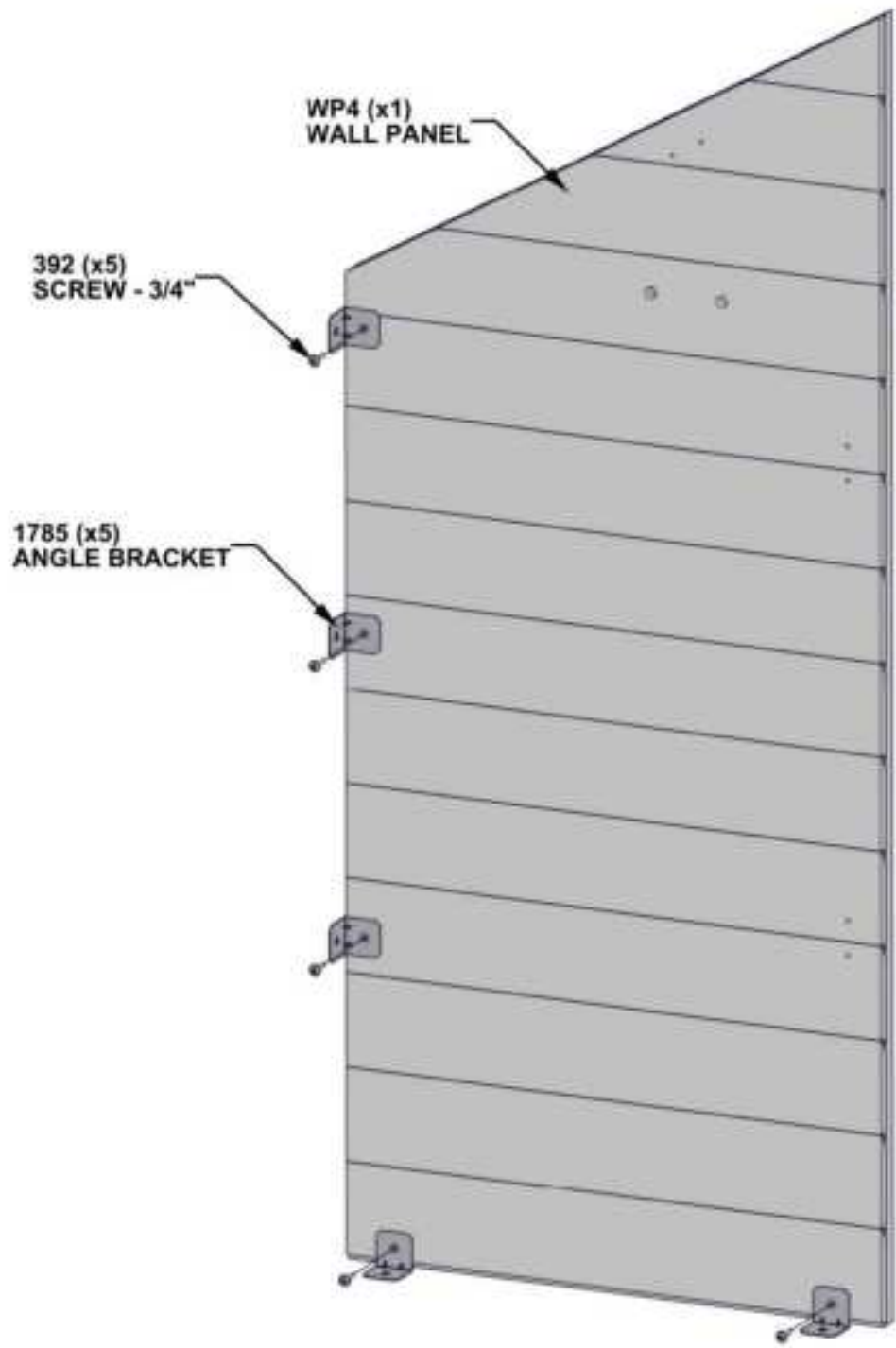

STEP 23B - WP3 ASSEMBLY

QTY	PART NUMBER	DESCRIPTION
6	H100392	SCREW PWH 8x3/4 BLK



WP3 WALL PANEL - W2A04942
(x1) 1 1/16"X19 1/16"X55 5/8" (27x484x1412)



A4M01785 ANGLE BRACKET
(x6)

- ALIGN BRACKETS WITH PILOT HOLES
- SQUARE BRACKETS BEFORE ATTACHING SCREWS

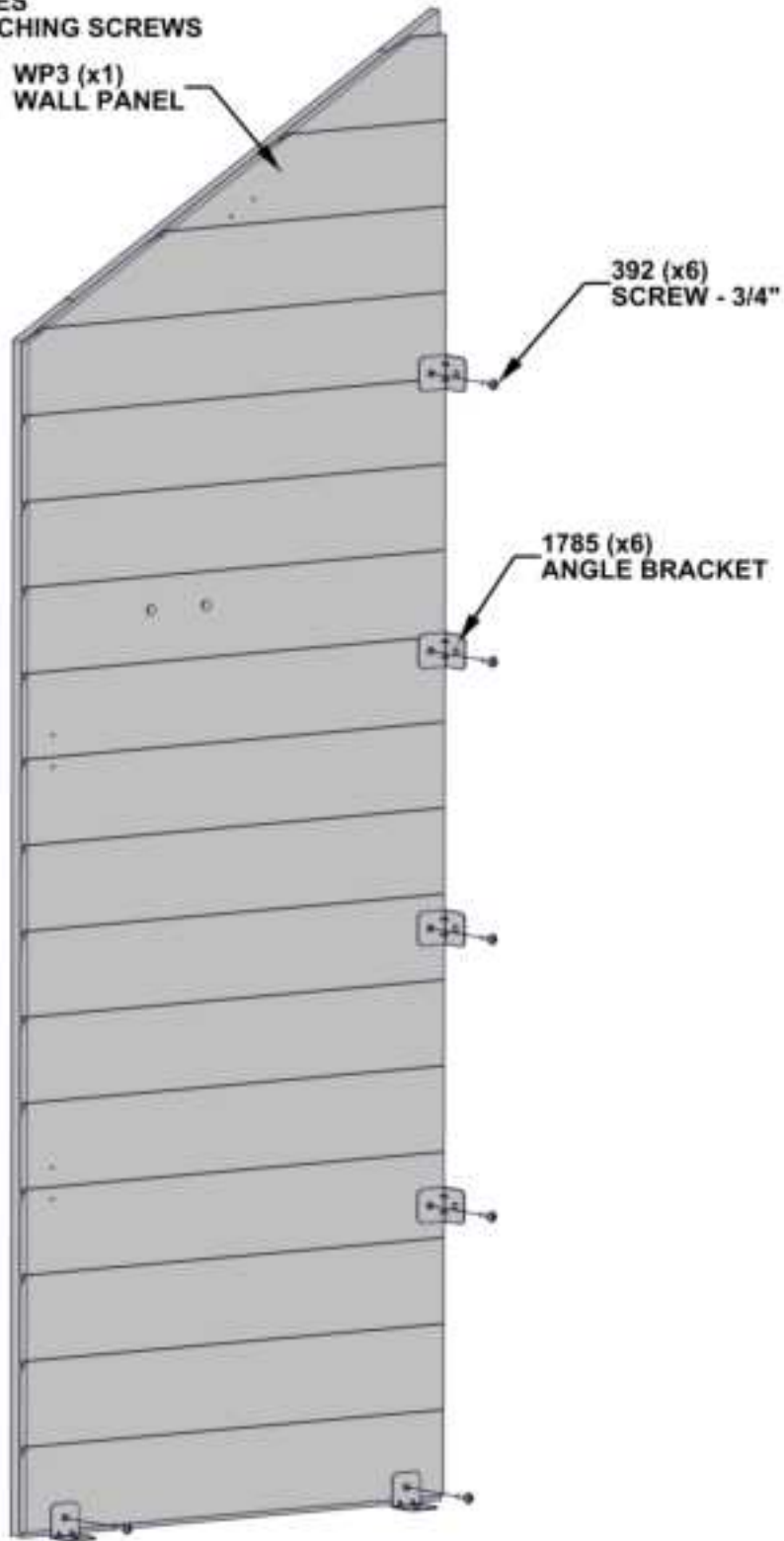

STEP 23C - WP3 & WP4 ASSEMBLY

QTY	PART NUMBER	DESCRIPTION
12	H100392	SCREW PWH 8x3/4 BLK



WP4 ASSEMBLY (x1) (FROM STEP 23 A)



WP3 ASSEMBLY (x1) (FROM STEP 23 B)



A4M00997 METAL CLEAT (x4)

- ALIGN BRACKETS WITH PILOT HOLES
- SQUARE BRACKETS BEFORE ATTACHING SCREWS

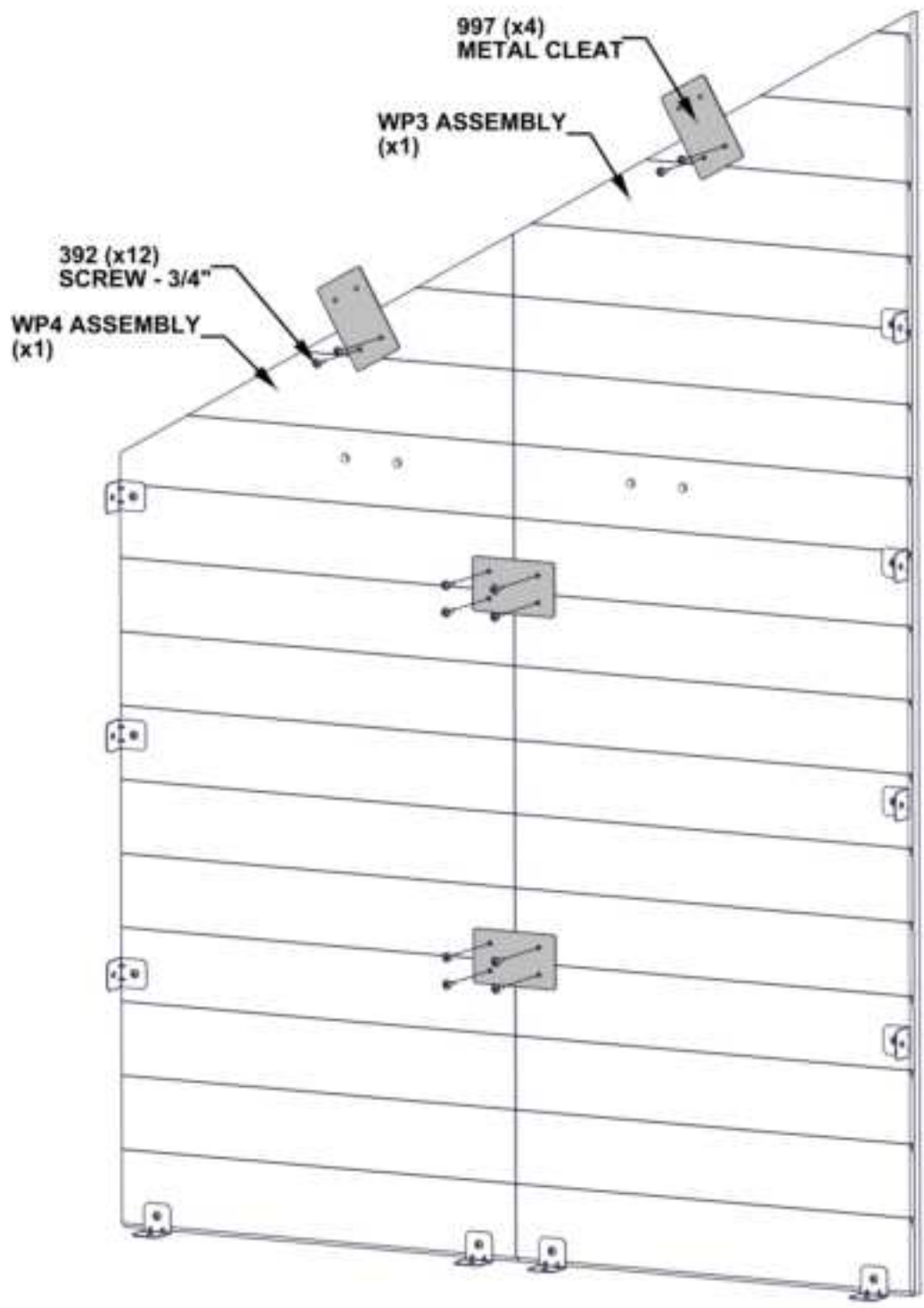

STEP 23D - ANIMAL ENCLOSURE ASSY

QTY	PART NUMBER	DESCRIPTION
7	H100797	SCREW PWH 8x1 BLK
8	H100392	SCREW PWH 8x3/4 BLK

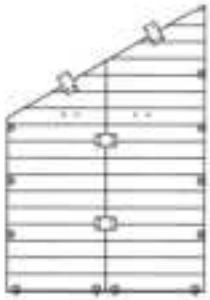

WP3 & WP4 ASSEMBLY
(x1) (FROM STEPS 23 C)

- PREDRILL 1/8" [3mm] PILOT HOLES FOR THE ATTACHMENT OF HARDWARE.
- USE PILOT HOLES TO ALIGN SCREWS.

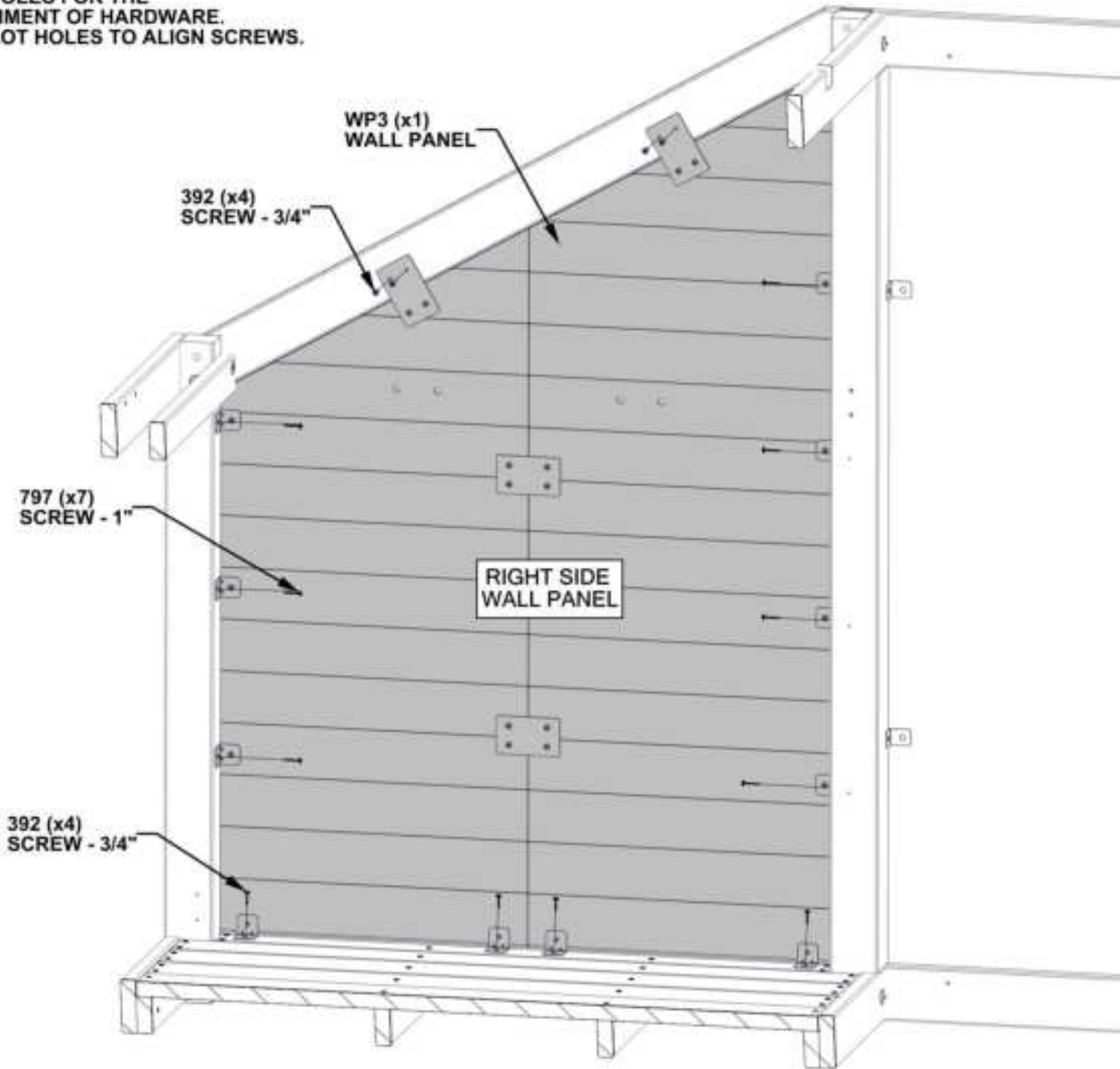

LEFT SIDE IS HIDDEN FOR DETAIL

STEP 24A - WP8 ASSEMBLY

QTY	PART NUMBER	DESCRIPTION
5	H100392	SCREW PWH 8x3/4 BLK



WP8 WALL PANEL - W2A04950
(x1) 1 1/16"X20 15/16"X33 1/2" (27x532x850)



A4M01785 ANGLE BRACKET
(x5)

- ALIGN BRACKETS WITH PILOT HOLES
- SQUARE BRACKETS BEFORE ATTACHING SCREWS

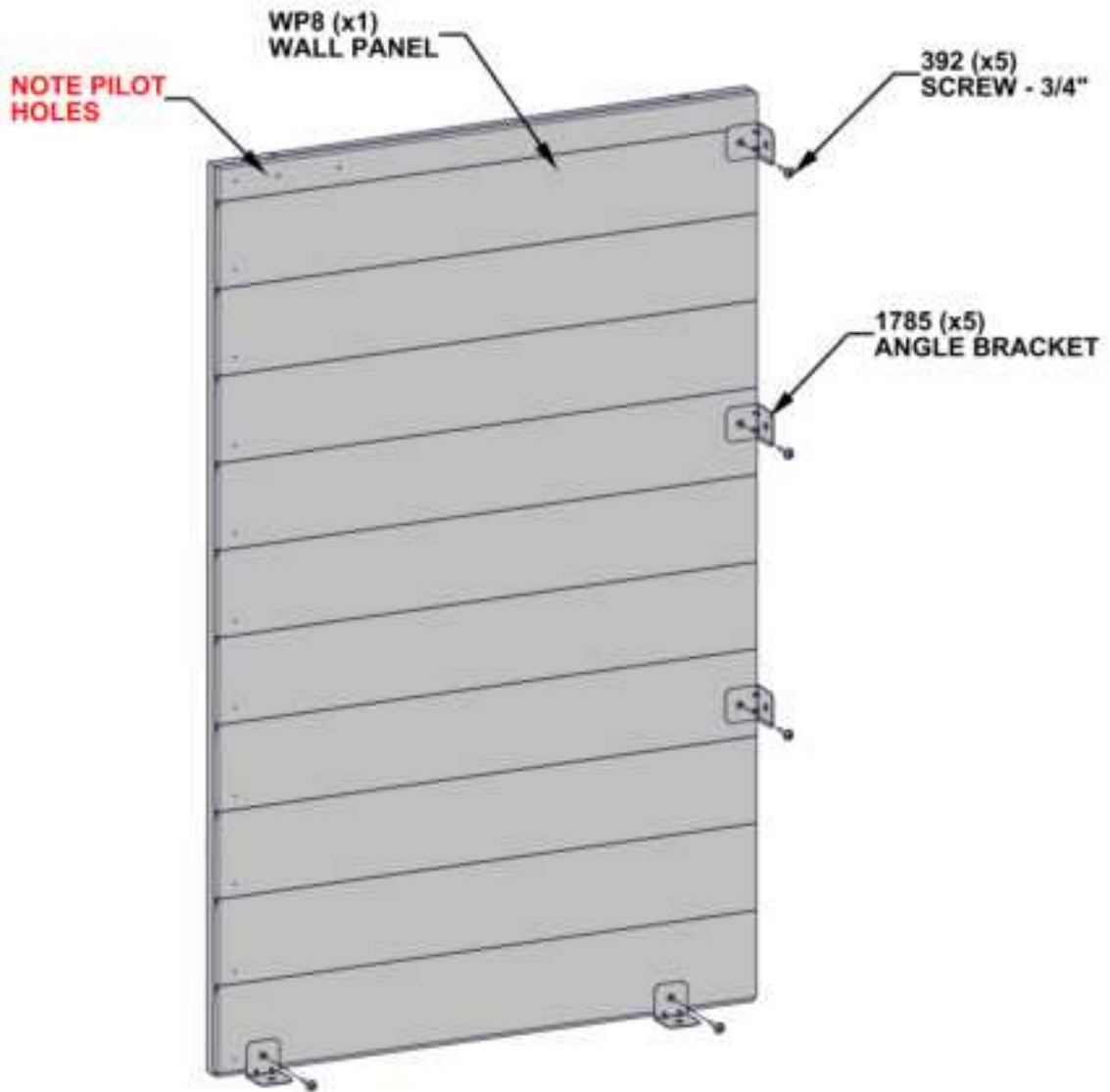

STEP 24B - ANIMAL ENCLOSURE ASSY

QTY	PART NUMBER	DESCRIPTION
3	H100797	SCREW PWH 8x1 BLK
4	H100392	SCREW PWH 8x3/4 BLK



WP8 ASSEMBLY
(x1) (FROM STEP 24 A)

- PREDRILL 1/8" [3mm] PILOT HOLES FOR THE ATTACHMENT OF HARDWARE.
- USE PILOT HOLES TO ALIGN SCREWS.

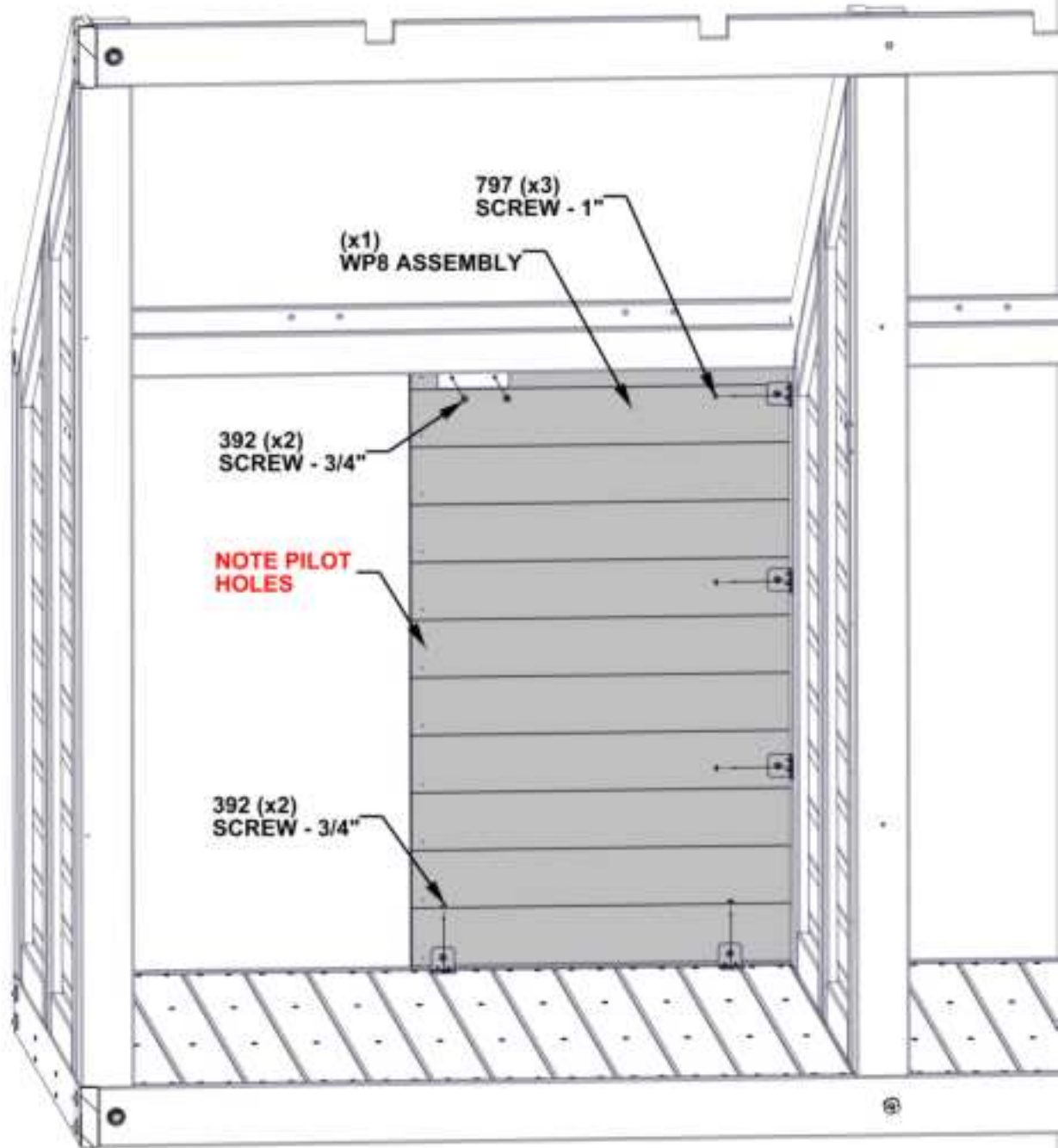

FRONT SIDE IS HIDDEN FOR DETAIL

STEP 25A - DP2 DOOR ASSEMBLY

QTY	PART NUMBER	DESCRIPTION
11	H100627	SCREW PFH 6x3/4 BLK



DP2 DOG HOUSE DOOR - W2A04948
(x1) 1 1/4"X18 7/16"X33 1/16" (32x469x840)



A4M02726 HINGE 832mm

- USE PILOT HOLES TO ALIGN SCREWS

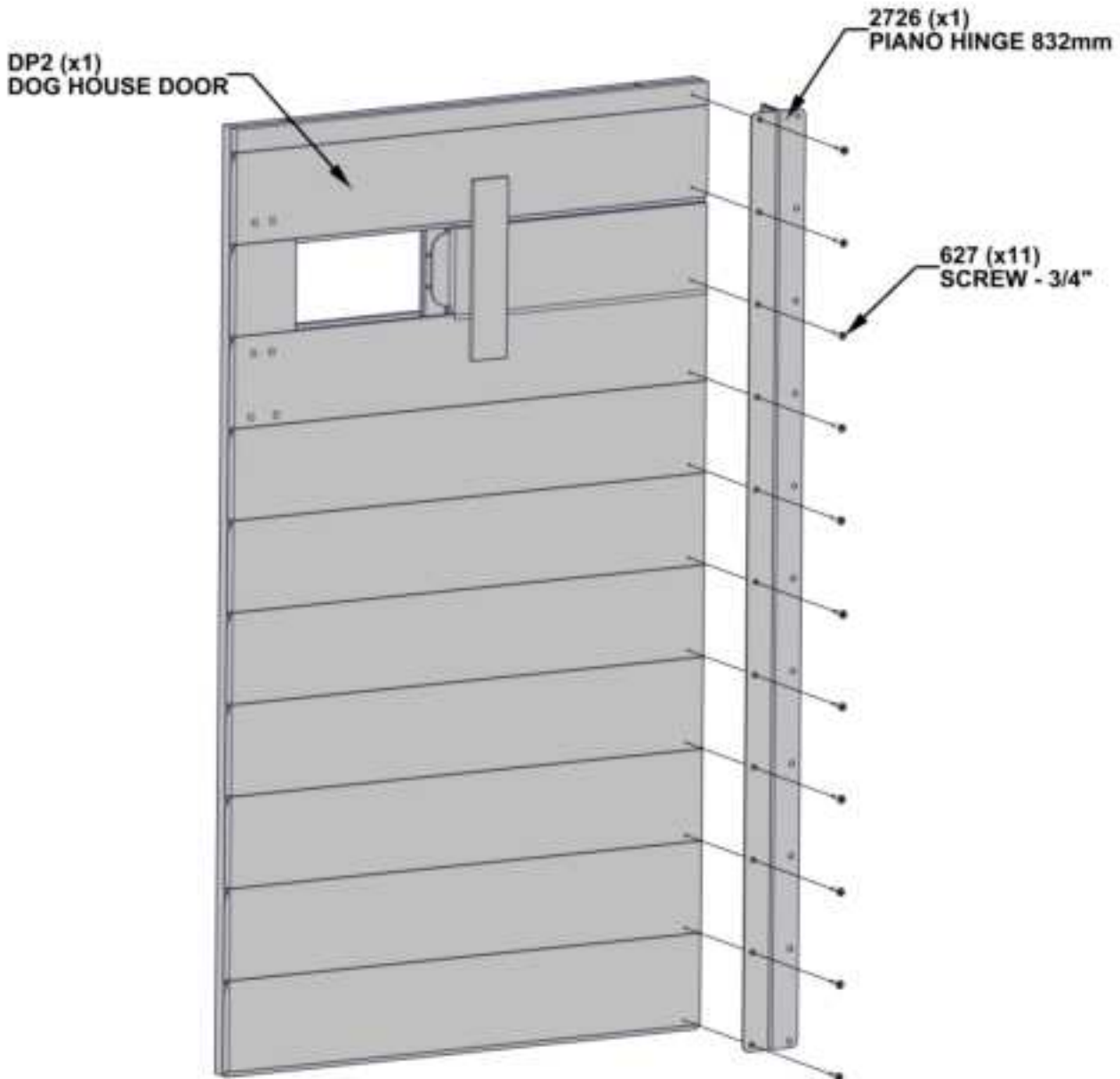

STEP 25B - ANIMAL ENCLOSURE ASSY

QTY	PART NUMBER	DESCRIPTION
11	H100627	SCREW PFH 6x3/4 BLK

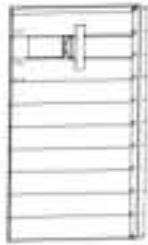

DP2 DOOR PANEL & PIANO HINGE ASSEMBLY
(x1) (FROM STEP 25 A)

- USE PILOT HOLES TO ALIGN SCREWS

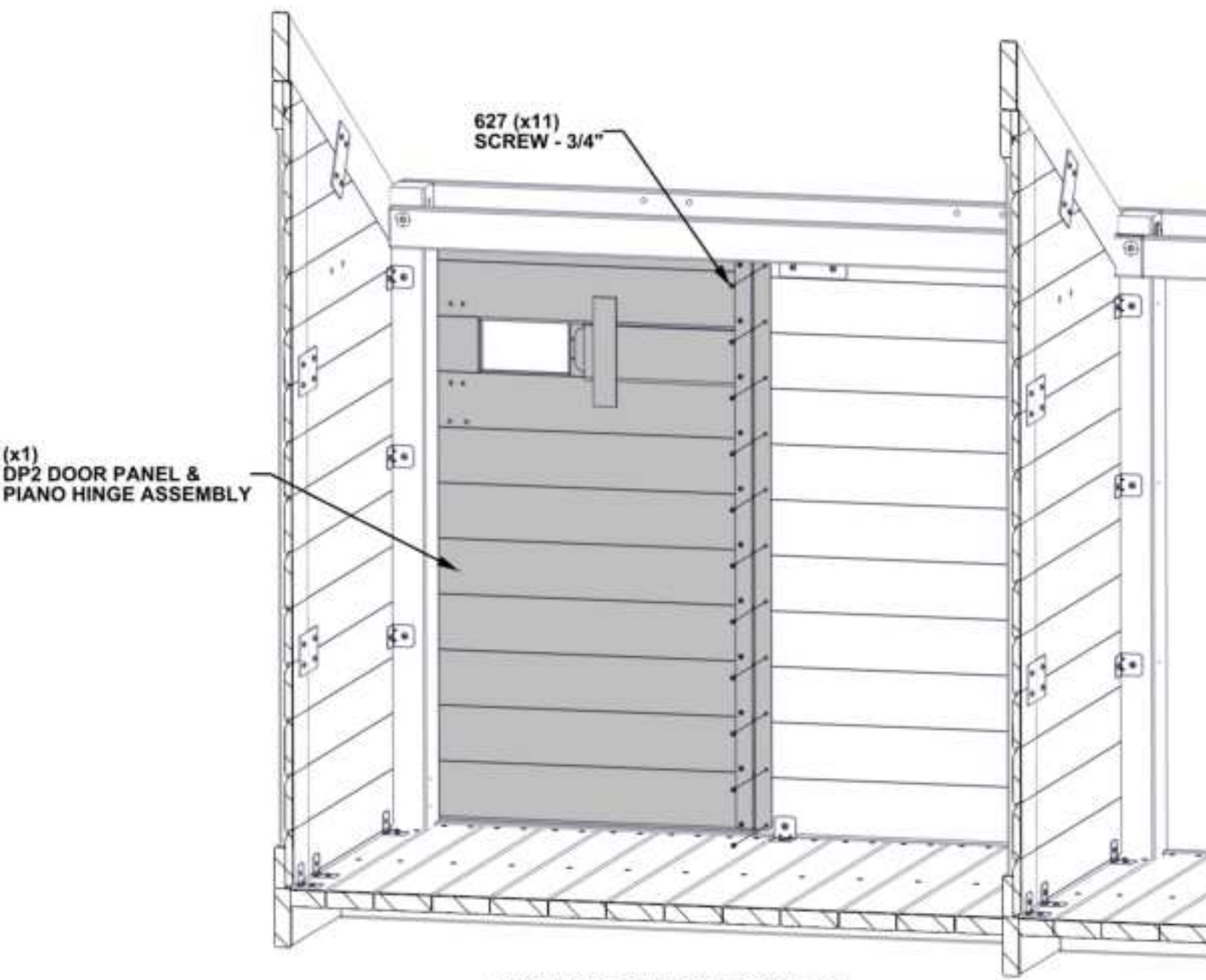

FRONT SIDE IS HIDDEN FOR DETAIL

STEP 25C - ANIMAL ENCLOSURE ASSY

QTY	PART NUMBER	DESCRIPTION
2	H100200	SCREW PFH 8x1 1/2 BLK



N3 STOP BLOCK - W4L22556
(x1) 5/8"x1 7/8"x3 3/8" (16x48x86)

- USE PILOT HOLES TO ALIGN SCREWS

200 (x2)
SCREW - 1 1/2"

N3 (x1)
STOP BLOCK

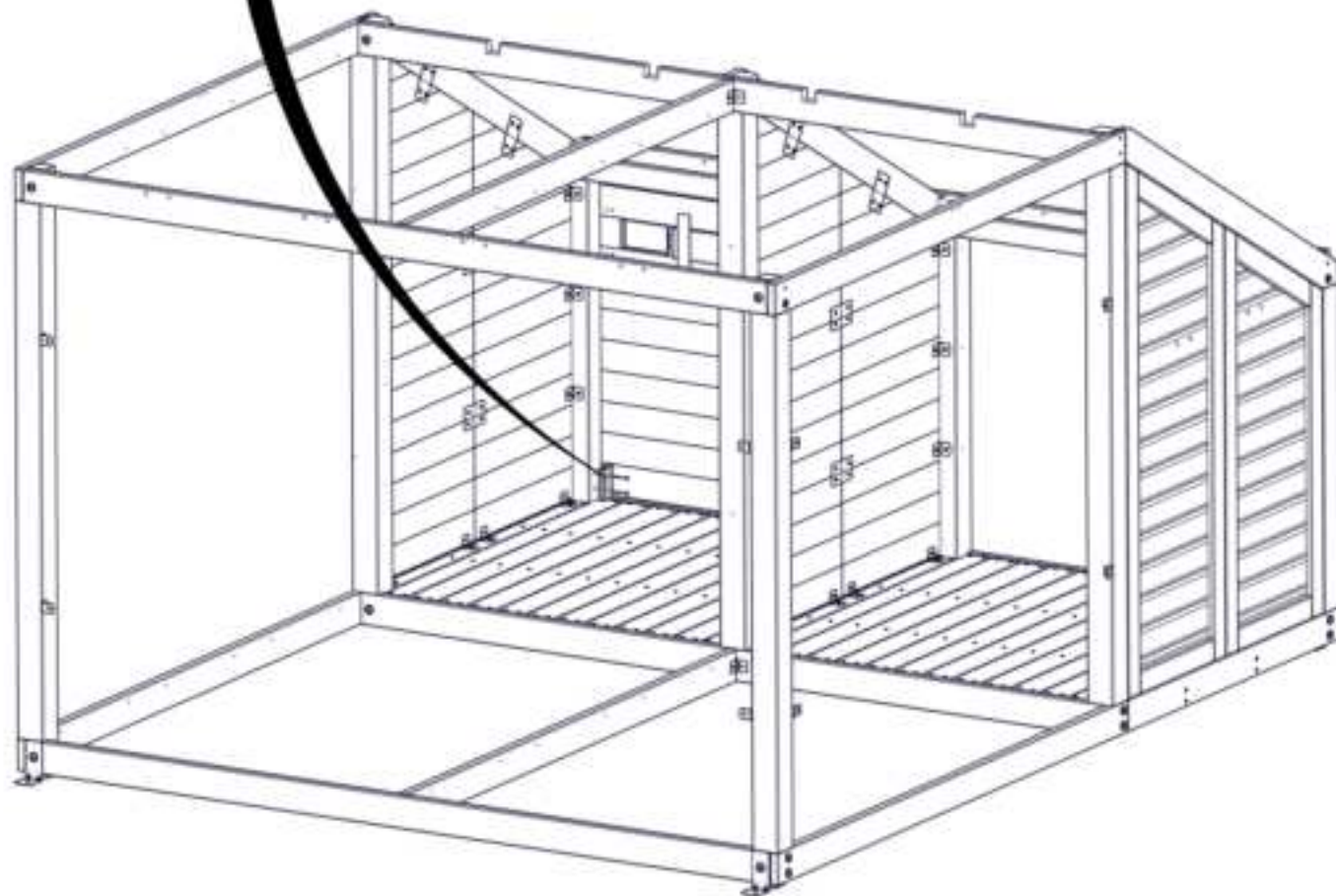
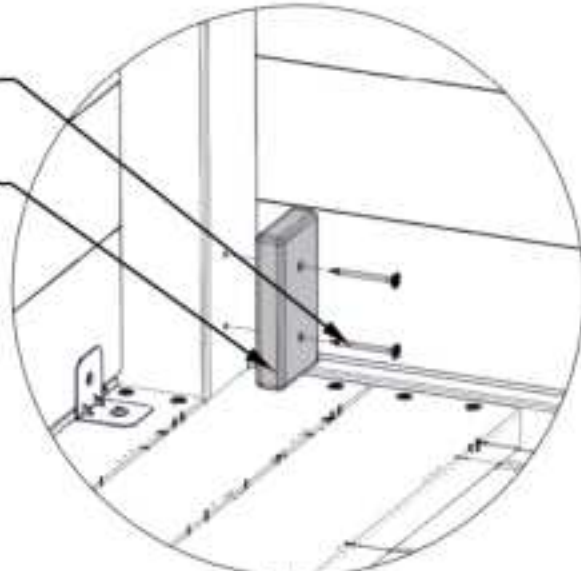

STEP 26A - WP7 ASSEMBLY

QTY	PART NUMBER	DESCRIPTION
5	H100392	SCREW PWH 8x3/4 BLK



WP7 WALL PANEL - W2A04946
(x1) 1 1/16"X20 15/16"X33 1/2" (27x532x850)



A4M01785 ANGLE BRACKET
(x5)

- ALIGN BRACKETS WITH PILOT HOLES
- SQUARE BRACKETS BEFORE ATTACHING SCREWS

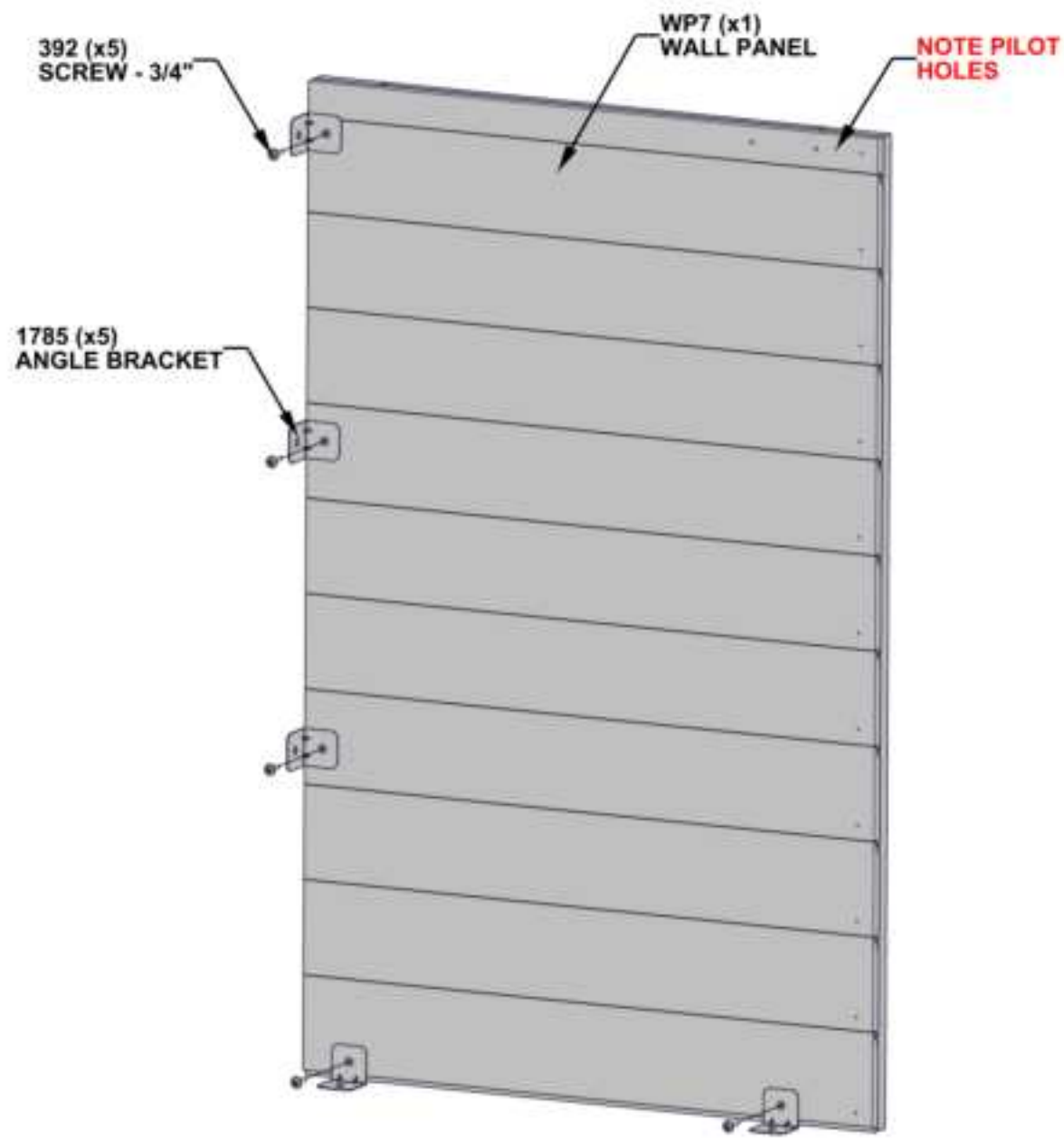

STEP 26B - ANIMAL ENCLOSURE ASSY

QTY	PART NUMBER	DESCRIPTION
3	H100797	SCREW PWH 8x1 BLK
4	H100392	SCREW PWH 8x3/4 BLK



WP7 ASSEMBLY
(x1) (FROM STEP 26 A)

- PREDRILL 1/8" [3mm] PILOT HOLES FOR THE ATTACHMENT OF HARDWARE.
- USE PILOT HOLES TO ALIGN SCREWS.

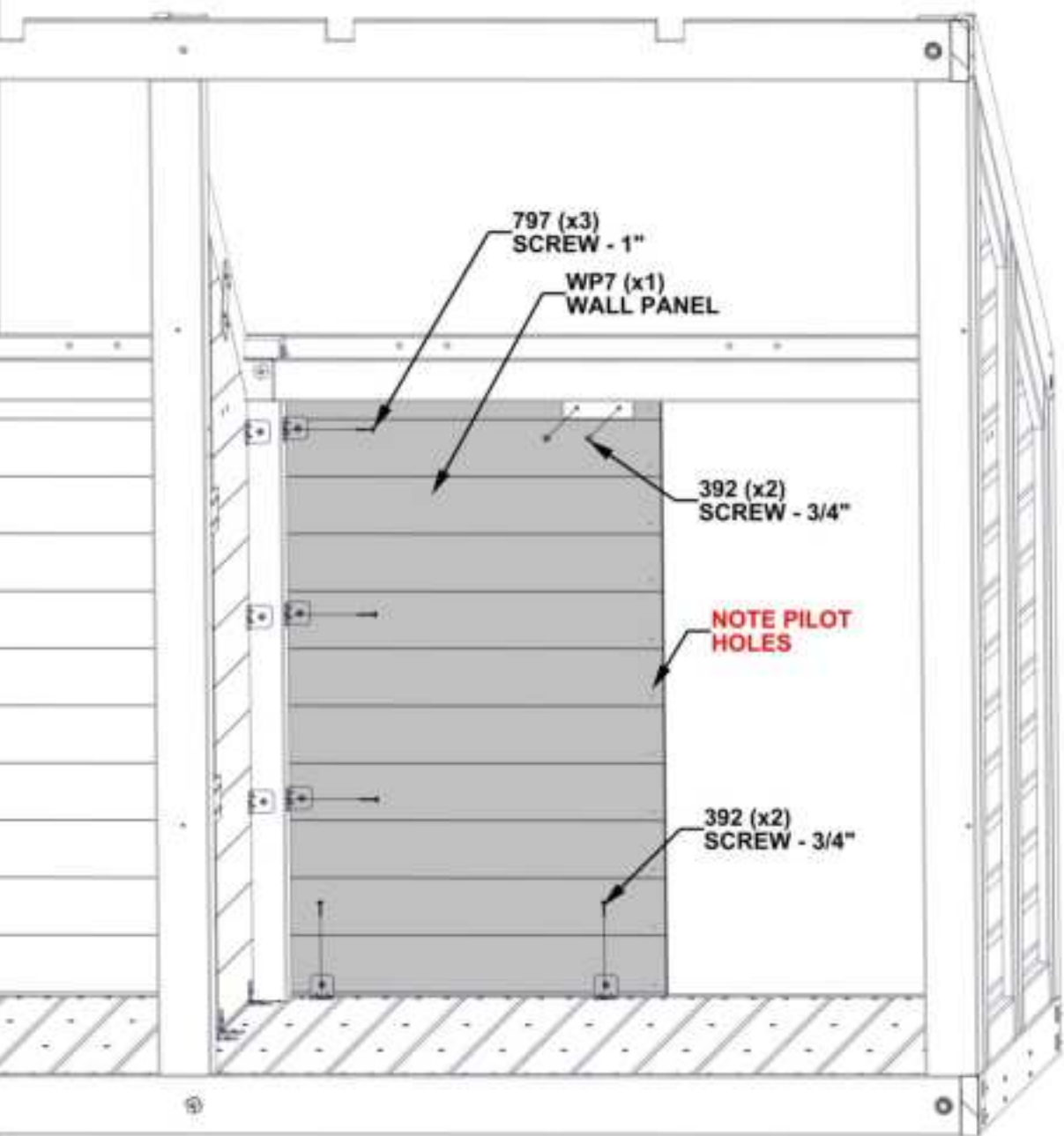

FRONT SIDE IS HIDDEN FOR
DETAIL

STEP 27A - DP1 DOOR ASSEMBLY

QTY	PART NUMBER	DESCRIPTION
11	H100627	SCREW PFH 6x3/4 BLK



DP1 DOG HOUSE DOOR - W2A04947
 (x1) 1 1/4"X18 7/16"X33 1/16" (32x469x840)



A4M02726 HINGE 832mm

- USE PILOT HOLES TO ALIGN SCREWS

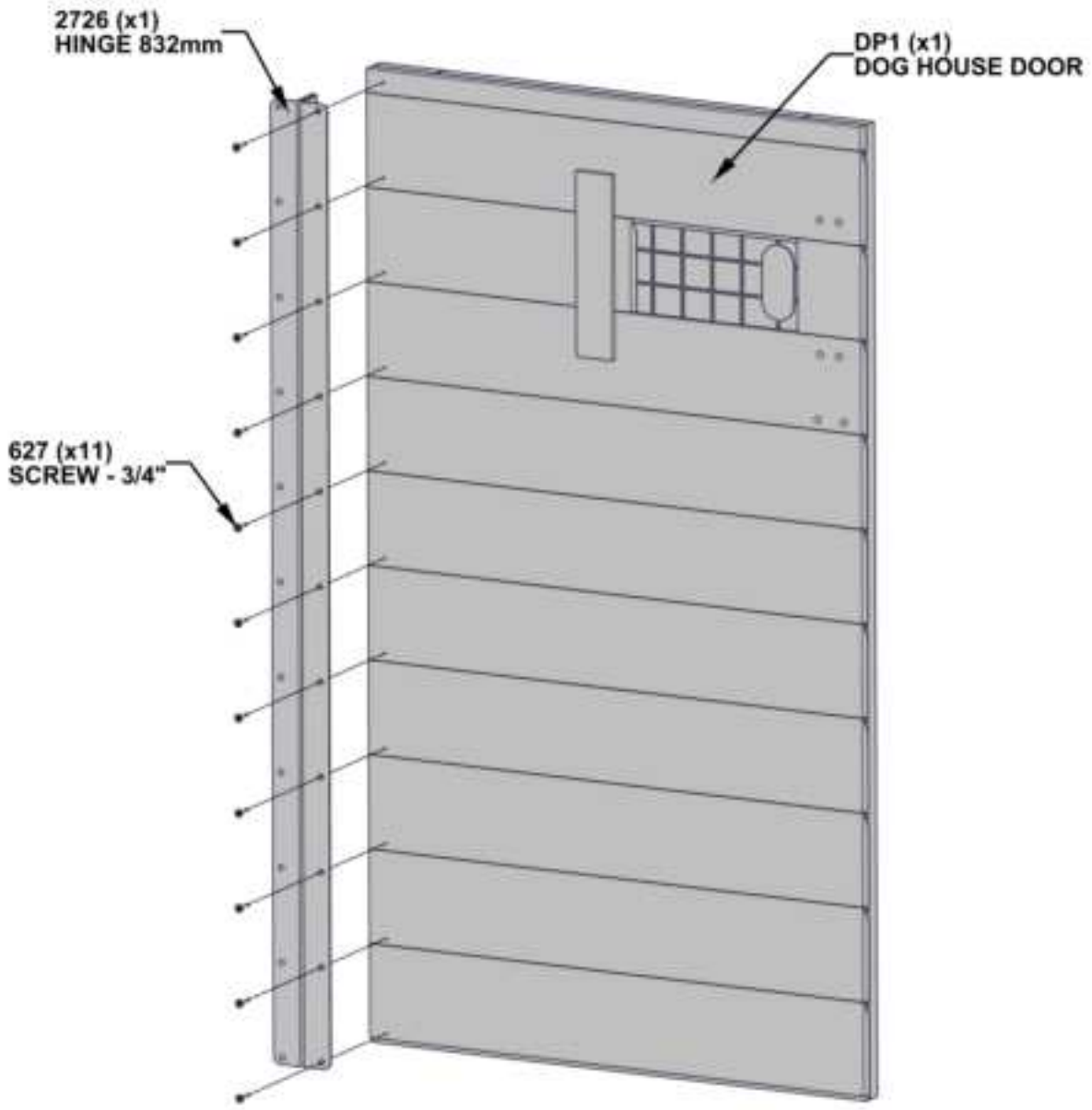

STEP 27B - ANIMAL ENCLOSURE ASSY

QTY	PART NUMBER	DESCRIPTION
11	H100627	SCREW PFH 6x3/4 BLK

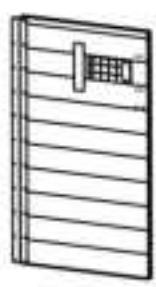

DP1 DOOR PANEL & PIANO HINGE ASSEMBLY
(x1) (FROM STEP 27 A)

- USE PILOT HOLES TO ALIGN SCREWS

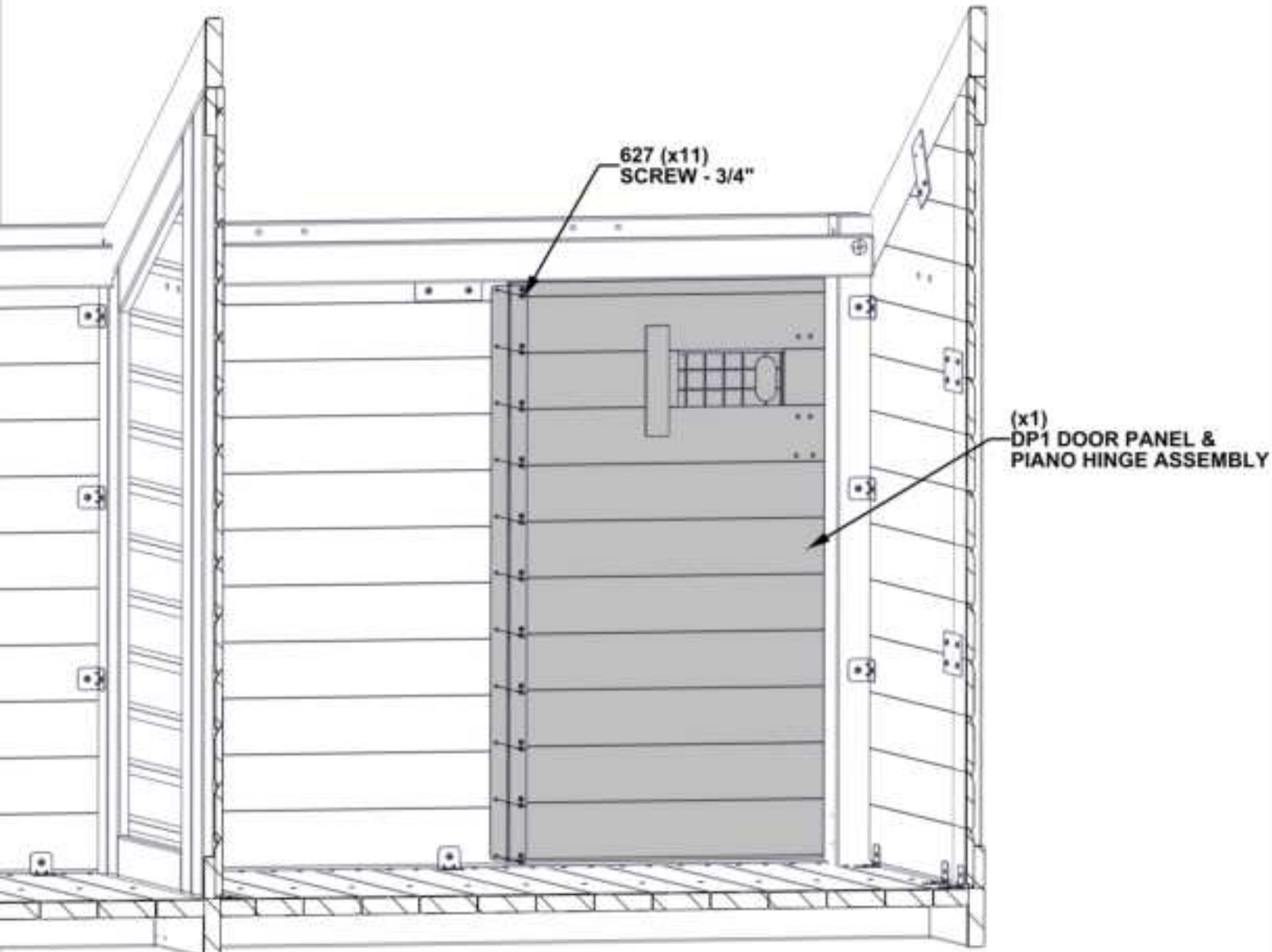

FRONT SIDE IS HIDDEN FOR DETAIL

STEP 27C - ANIMAL ENCLOSURE ASSY

QTY	PART NUMBER	DESCRIPTION
2	H100200	SCREW PFH 8x1 1/2 BLK



N3 STOP BLOCK - W4L22556
(x1) 5/8"x1 7/8"x3 3/8" (16x48x86)

- USE PILOT HOLES TO ALIGN SCREWS

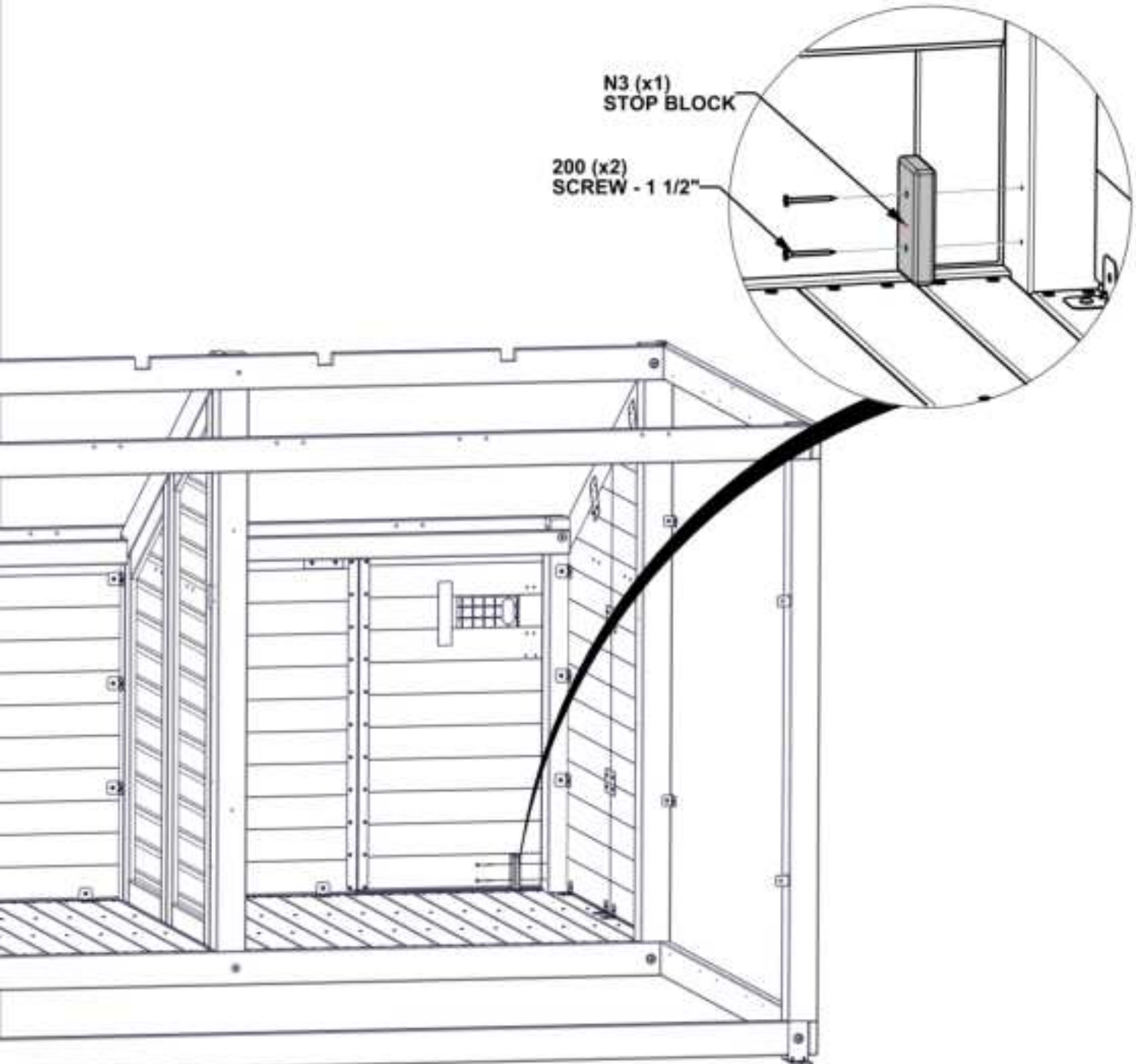

STEP 28A - WP2 ASSEMBLY

QTY	PART NUMBER	DESCRIPTION
9	H100392	SCREW PWH 8x3/4 BLK

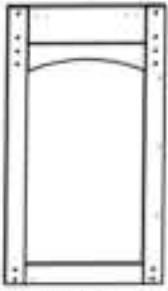

WP2 DOOR FRAME - W2404941
(x1) 1 7/16"X18 13/16"X33 1/2" (36x478x850)



A4M01785 ANGLE BRACKET
(x5)



A4M01846 Z TIE BRACKET
(x2)

- ALIGN BRACKETS WITH PILOT HOLES
- SQUARE BRACKETS BEFORE ATTACHING SCREWS

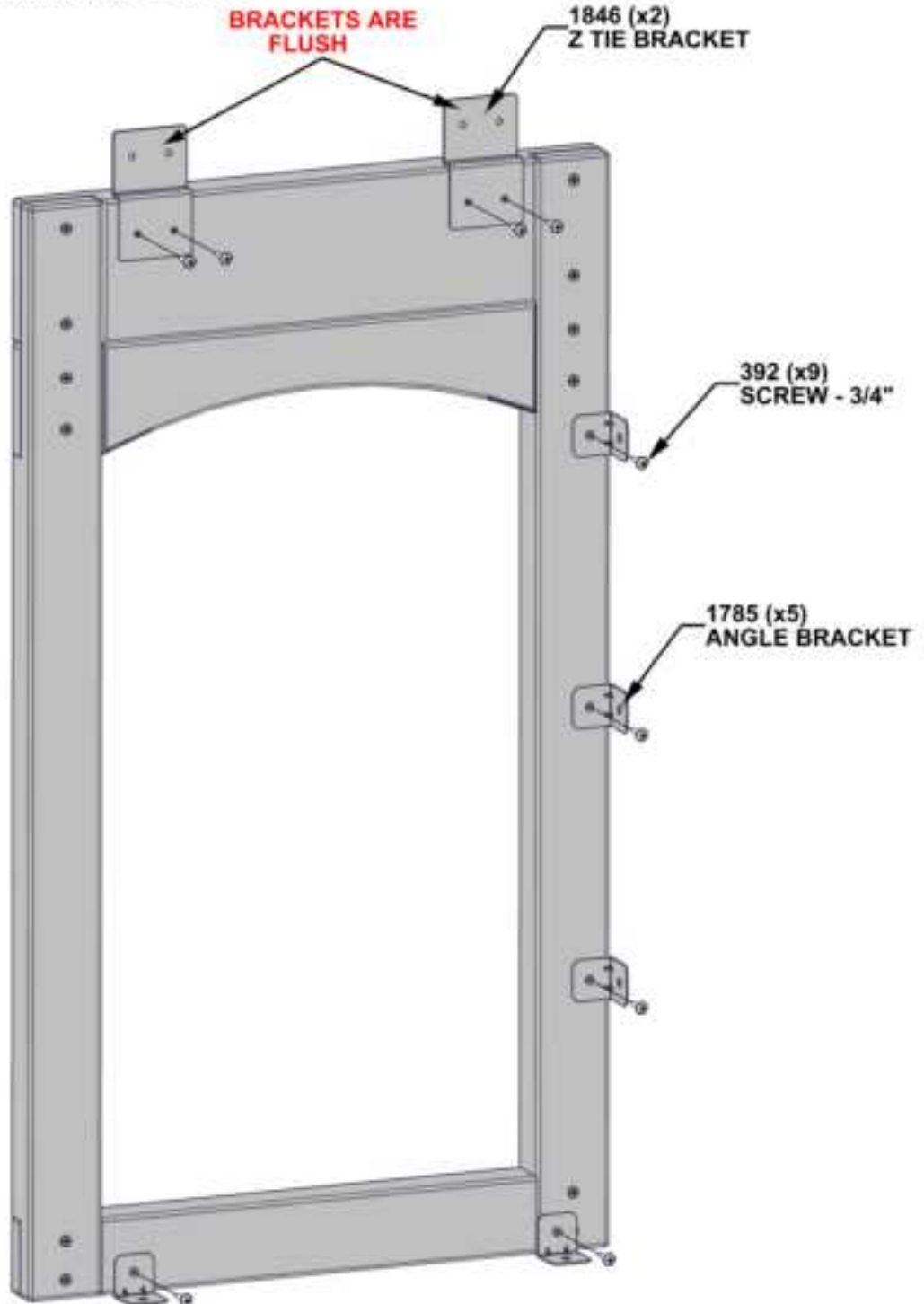

STEP 28B - ANIMAL ENCLOSURE ASSY

QTY	PART NUMBER	DESCRIPTION
3	H100797	SCREW PWH 8x1 BLK
2	H100392	SCREW PWH 8x3/4 BLK

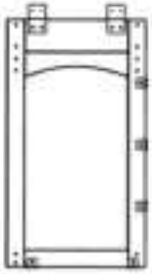

WP2 DOOR ASSEMBLY
(x1) (FROM STEP 28 A)

- PREDRILL 1/8" [3mm] PILOT HOLES FOR THE ATTACHMENT OF HARDWARE.
- USE PILOT HOLES TO ALIGN SCREWS.

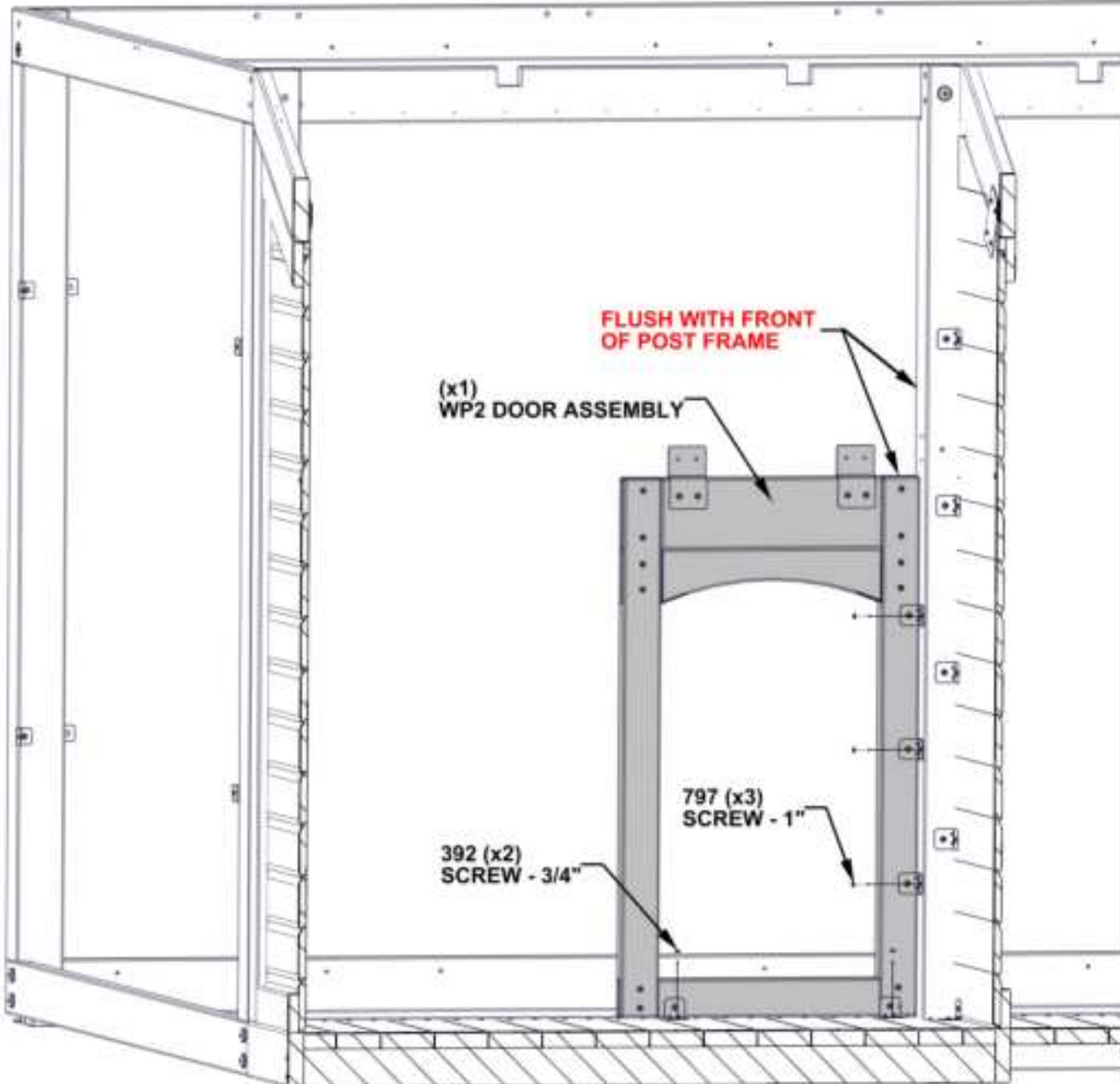

BACK SIDE IS HIDDEN FOR DETAIL

STEP 29A - WP1 ASSEMBLY

QTY	PART NUMBER	DESCRIPTION
7	H100392	SCREW PWH 8x3/4 BLK



WP1 WALL PANEL - W2A04940
(x1) 1 1/16"X21"X33 1/2" (27x534x850)



A4M01785 ANGLE BRACKET
(x5)



A4M0097 METAL CLEAT
(x1)

- ALIGN BRACKETS WITH PILOT HOLES
- SQUARE BRACKETS BEFORE ATTACHING SCREWS

1785 (x5)
ANGLE BRACKET

392 (x7)
SCREW - 3/4"

997 (x1)
METAL CLEAT

WP1 (x1)
WALL PANEL

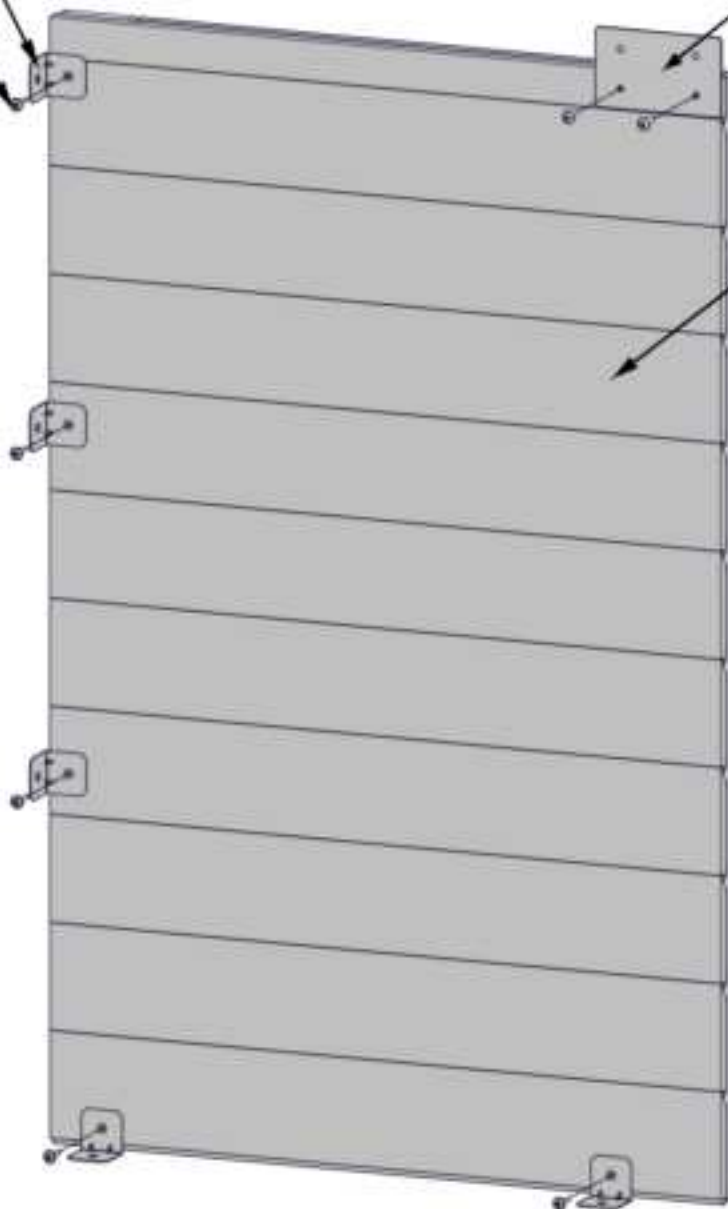

STEP 29B - ANIMAL ENCLOSURE ASSY

QTY	PART NUMBER	DESCRIPTION
3	H100797	SCREW PWH 8x1 BLK
2	H100392	SCREW PWH 8x3/4 BLK



WP1 ASSEMBLY
(x1) (FROM STEP 29 A)

- PREDRILL 1/8" [3mm] PILOT HOLES FOR THE ATTACHMENT OF HARDWARE.
- USE PILOT HOLES TO ALIGN SCREWS.

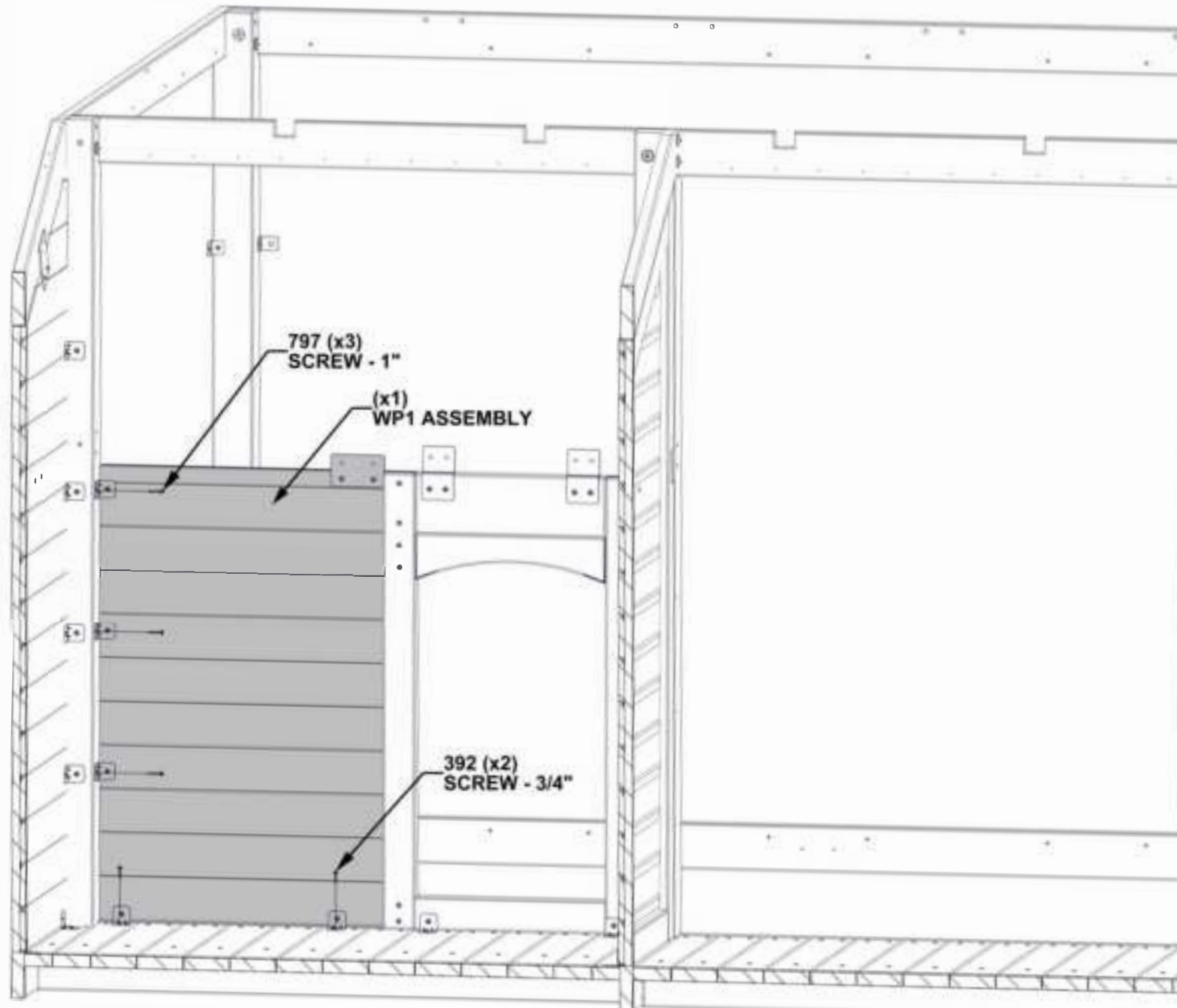

BACK SIDE IS HIDDEN FOR DETAIL

STEP 30 - WP9 ASSEMBLY

QTY	PART NUMBER	DESCRIPTION
9	H100392	SCREW PWH 8x3/4 BLK

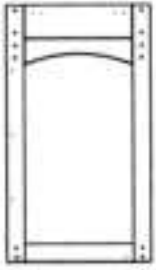

WP9 DOOR FRAME - W2A04951
(x1) 1 7/16"X18 13/16"X33 1/2" (36x478x650)



A4M01785 ANGLE BRACKET
(x5)



A4M01846 Z TIE BRACKET
(x2)

- ALIGN BRACKETS WITH PILOT HOLES
- SQUARE BRACKETS BEFORE ATTACHING SCREWS

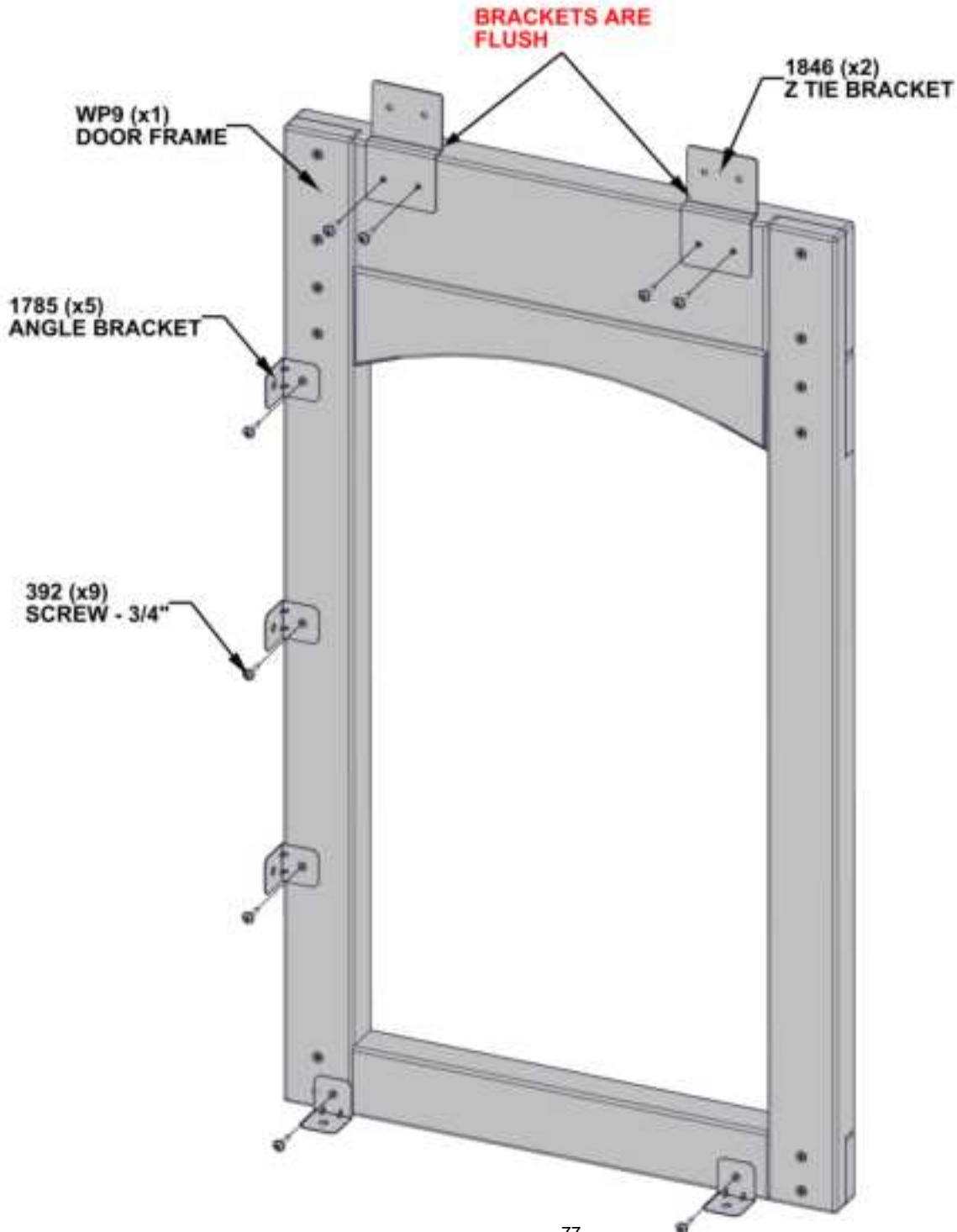

STEP 30B - ANIMAL ENCLOSURE ASSY

QTY	PART NUMBER	DESCRIPTION
3	H100797	SCREW PWH 8x1 BLK
2	H100392	SCREW PWH 8x3/4 BLK

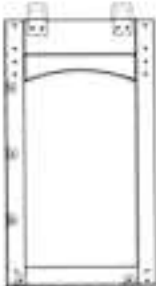

WP9 DOOR ASSEMBLY
(x1) (FROM STEP 30A)

- PREDRILL 1/8" [3mm] PILOT HOLES FOR THE ATTACHMENT OF HARDWARE.
- USE PILOT HOLES TO ALIGN SCREWS.

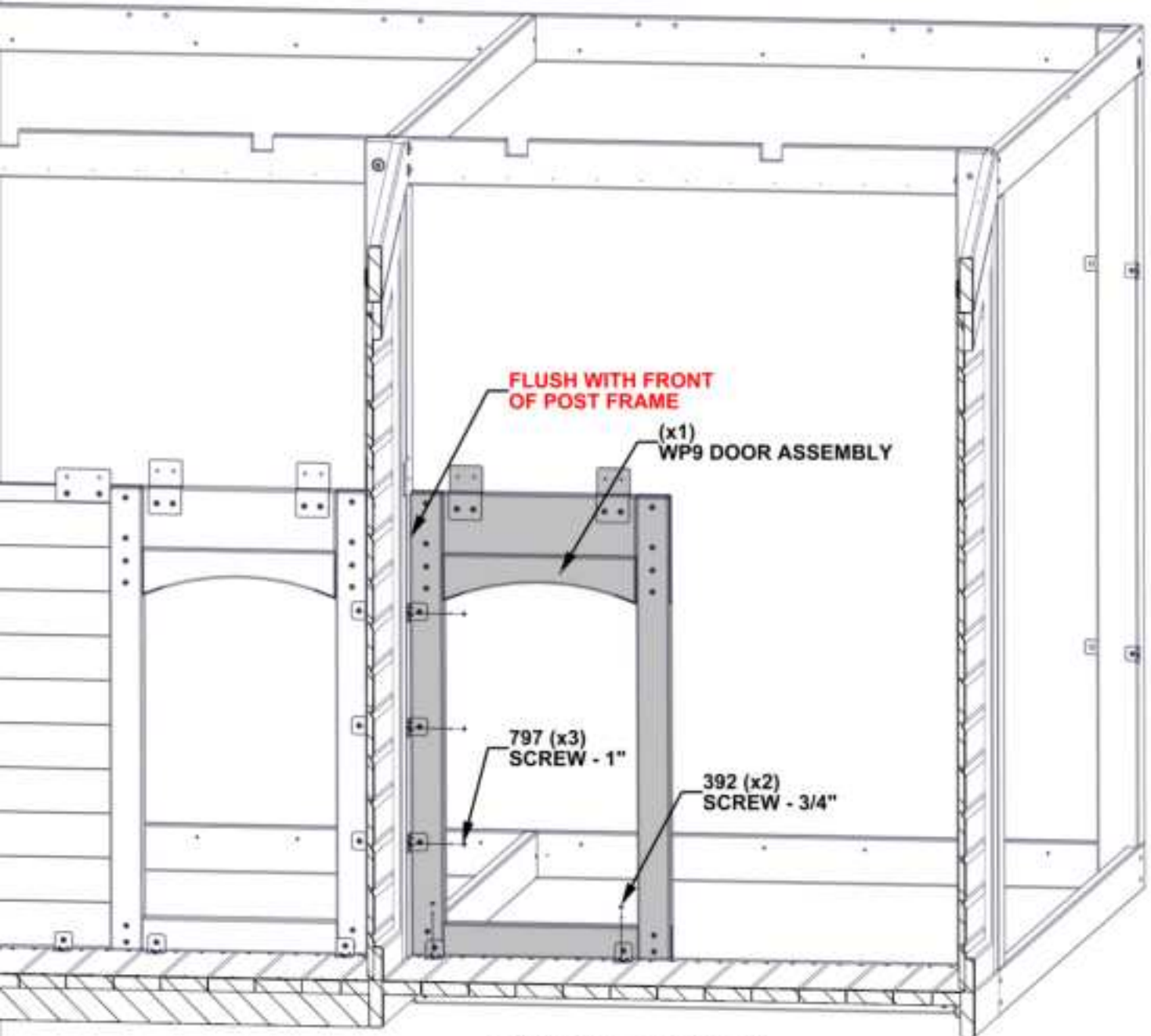

BACK SIDE IS HIDDEN FOR
DETAIL

STEP 31A - WP10 ASSEMBLY

QTY	PART NUMBER	DESCRIPTION
7	H100392	SCREW PWH 8x3/4 BLK



WP10 WALL PANEL - W2A04952
(x1) 1 1/16"X21"X33 1/2" (27x534x850)



A4M01785 ANGLE BRACKET
(x5)



A4M00997 METAL CLEAT
(x1)

- ALIGN BRACKETS WITH PILOT HOLES
- SQUARE BRACKETS BEFORE ATTACHING SCREWS

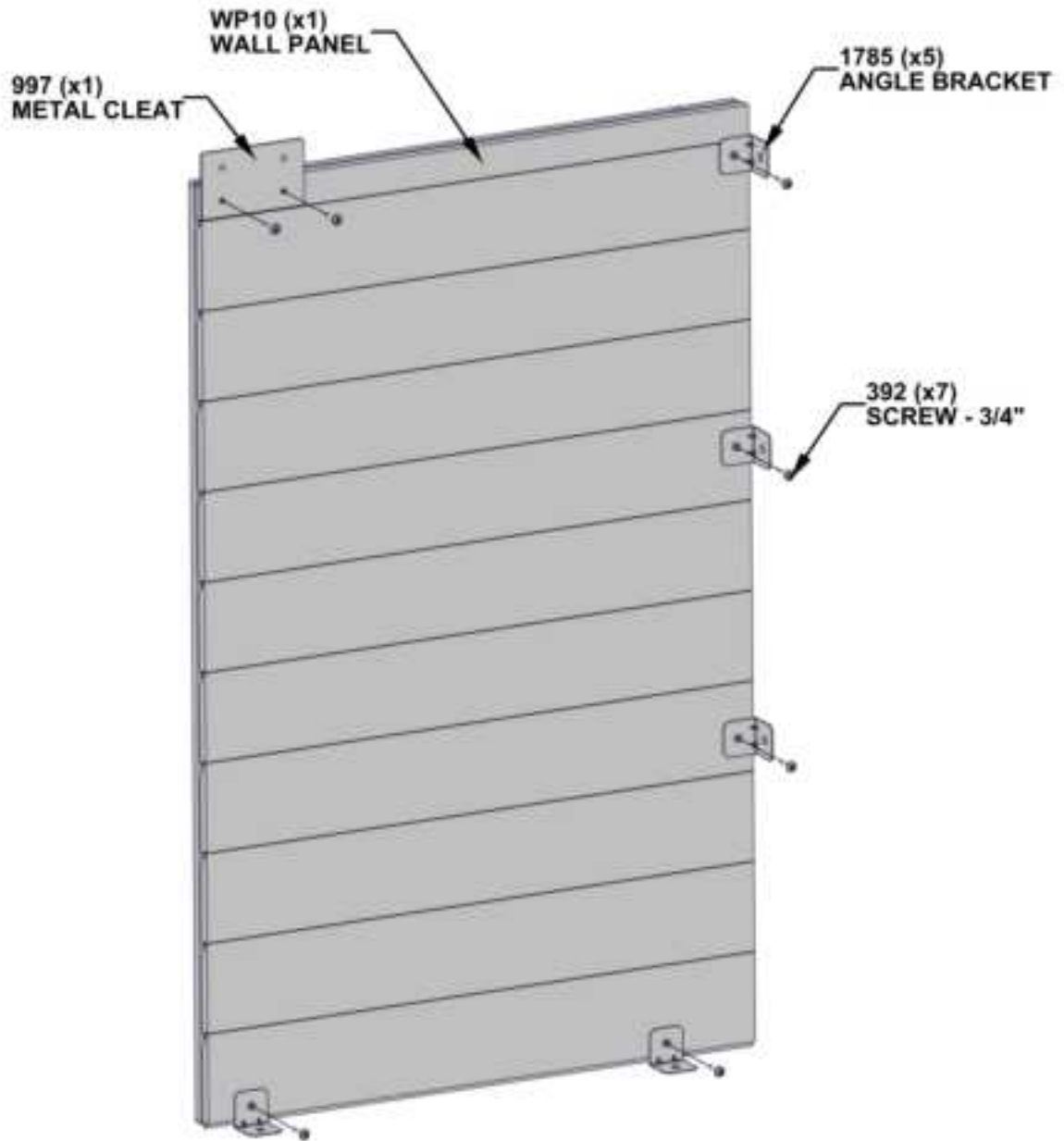

STEP 31B - ANIMAL ENCLOSURE ASSY

QTY	PART NUMBER	DESCRIPTION
3	H100797	SCREW PWH 8x1 BLK
2	H100392	SCREW PWH 8x3/4 BLK

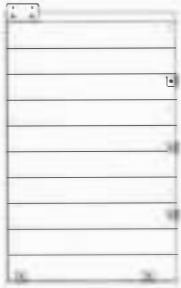

WP10 ASSEMBLY
(x1) (FROM STEP 31 A)

- PREDRILL 1/8" [3mm] PILOT HOLES FOR THE ATTACHMENT OF HARDWARE.
- USE PILOT HOLES TO ALIGN SCREWS.

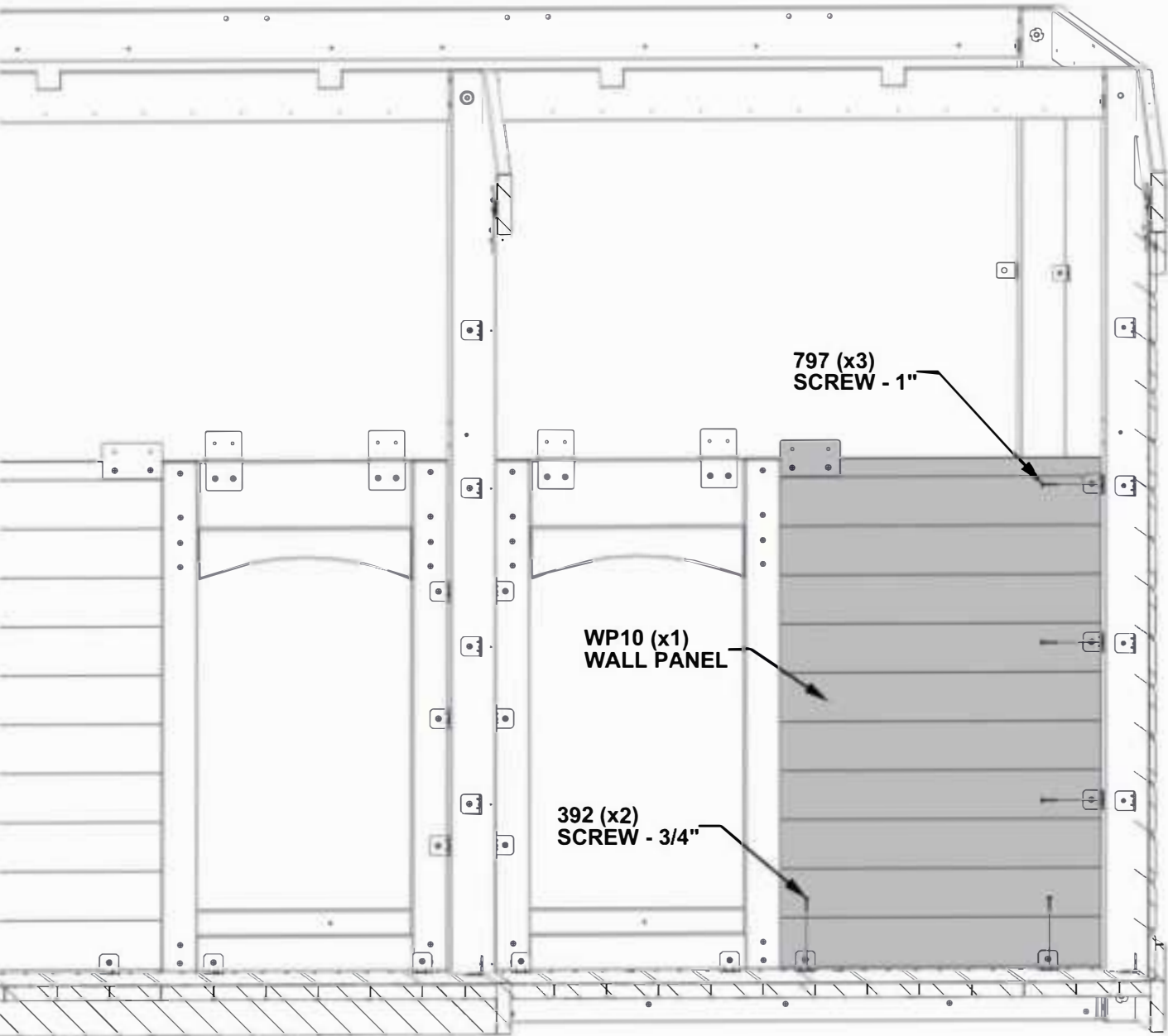

BACK SIDE IS HIDDEN FOR DETAIL

STEP 32A - H15 ASSEMBLY

QTY	PART NUMBER	DESCRIPTION
4	H100663	BOLT WH 5/16x3/4 BLK
4	H100469	NUT BARREL WH 5/16X5/8 BLK
4	H100198	WASHER LOCK EXT 8x19



H15 WALL BOARD - W4L22545
(x1) 15/16"X3 3/8"X39 15/16" (24x86x1014)



A4M00855 L BRACKET
(x2)

- ALIGN BRACKETS WITH PILOT HOLES
- SQUARE BRACKETS BEFORE ATTACHING SCREWS

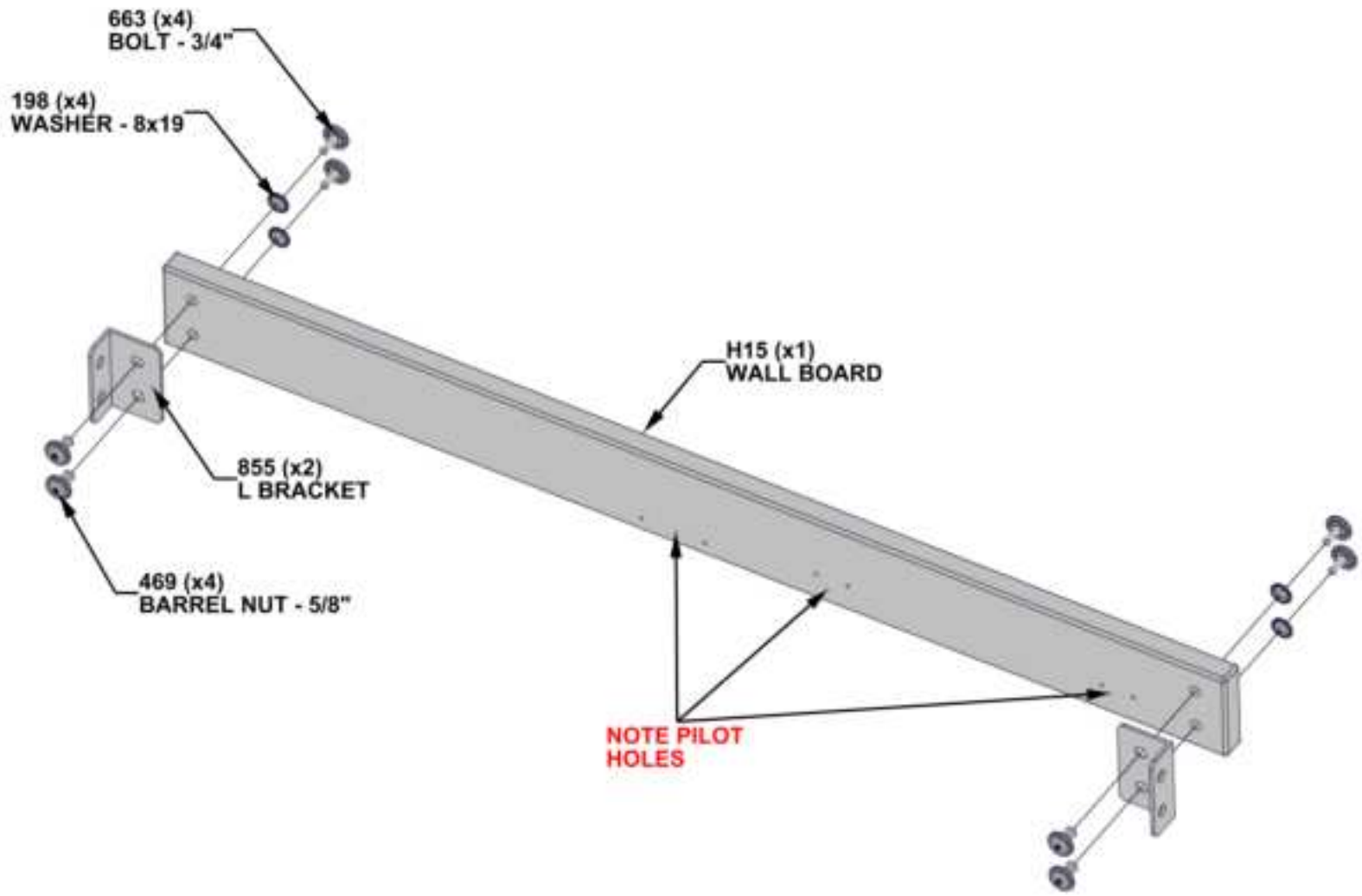

STEP 32 B - ANIMAL ENCLOSURE ASSY

QTY	PART NUMBER	DESCRIPTION
4	H100854	LAG SCREW WH 5/16x1 BLK
6	H100392	SCREW PWH 8x3/4 BLK

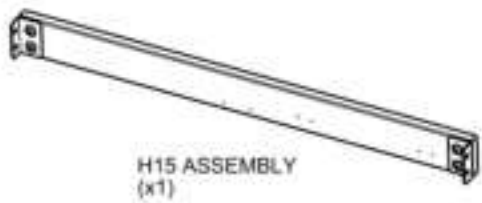

- USE PILOT HOLES TO ALIGN SCREWS

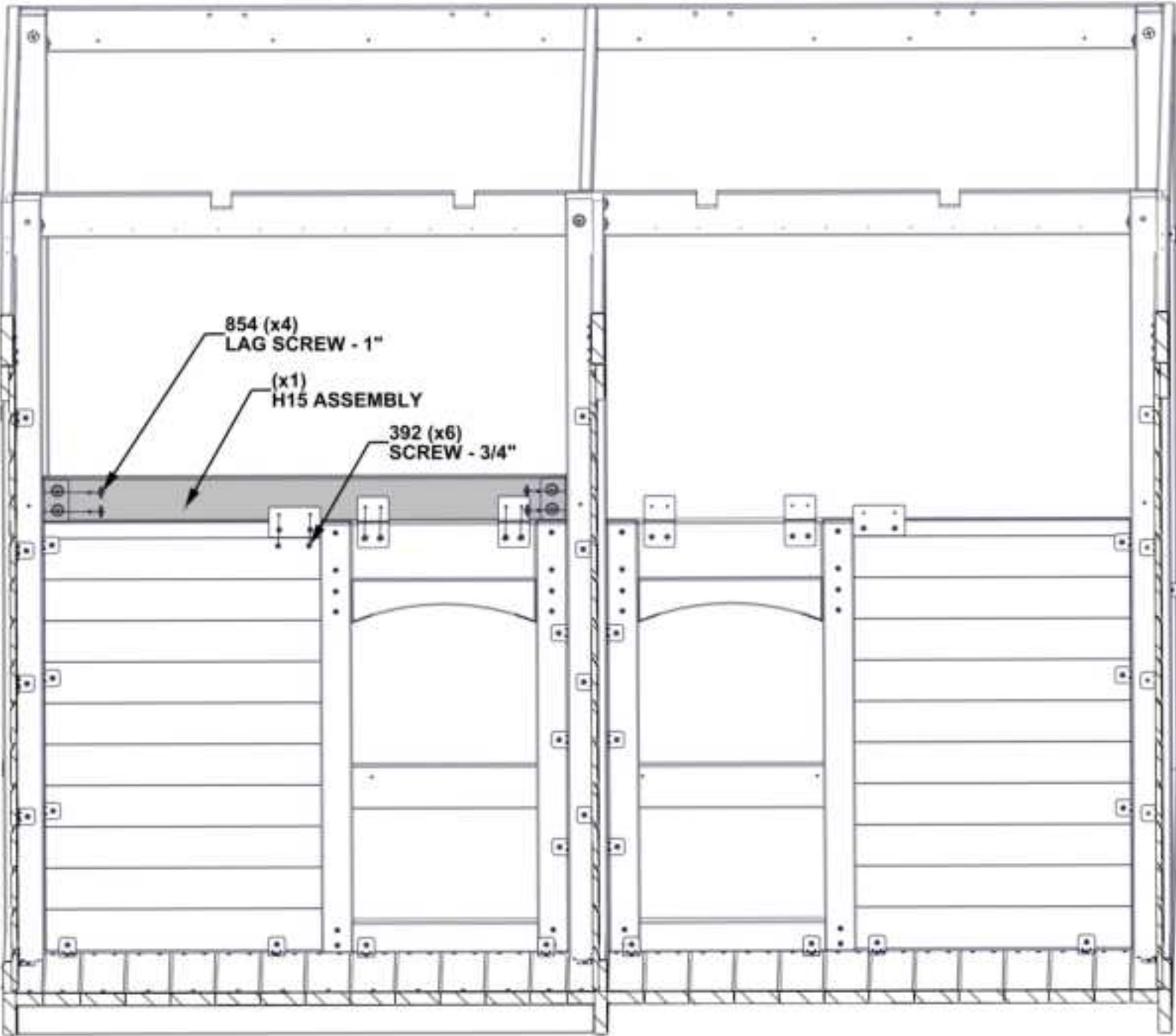

BACK SIDE IS HIDDEN FOR DETAIL

STEP 33A - H17 ASSEMBLY

QTY	PART NUMBER	DESCRIPTION
4	H100663	BOLT WH 5/16x3/4 BLK
4	H100469	NUT BARREL WH 5/16X5/8 BLK
4	H100198	WASHER LOCK EXT 8x19



H17 WALL BOARD - W4L22557
(x1) 15/16"X3 3/8"X39 15/16" (24x86x1014)



A4M00855 L BRACKET
(x2)

- ALIGN BRACKETS WITH PILOT HOLES
- SQUARE BRACKETS BEFORE ATTACHING SCREWS

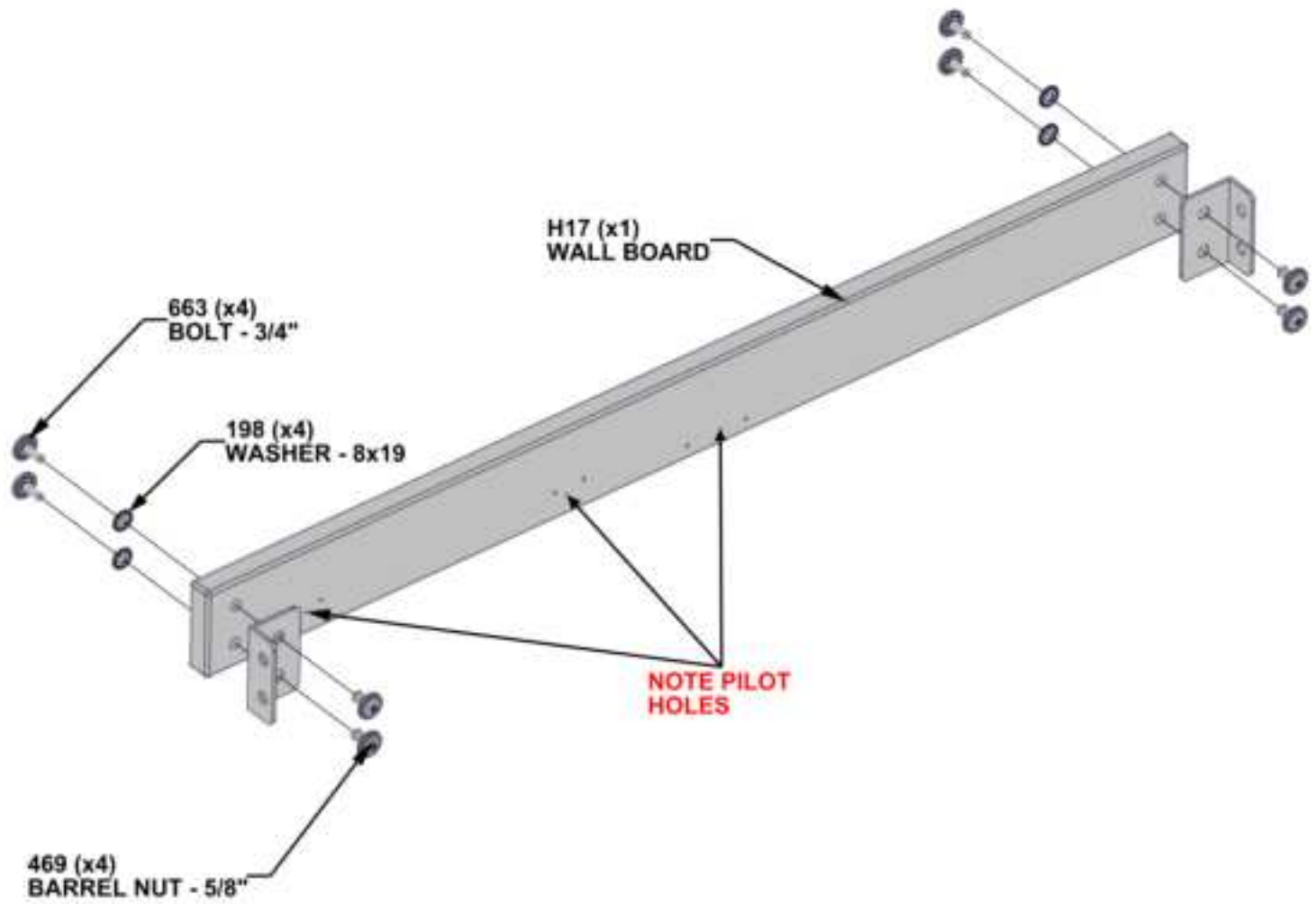

NOTE PILOT HOLES

STEP 33B - ANIMAL ENCLOSURE ASSY

QTY	PART NUMBER	DESCRIPTION
4	H100854	LAG SCREW WH 5/16x1 BLK
6	H100392	SCREW PWH 8x3/4 BLK

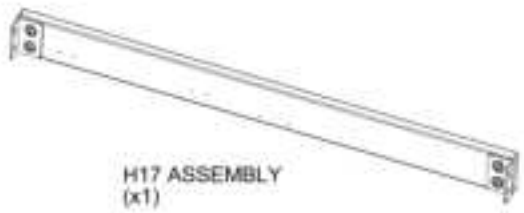

- USE PILOT HOLES TO ALIGN SCREWS

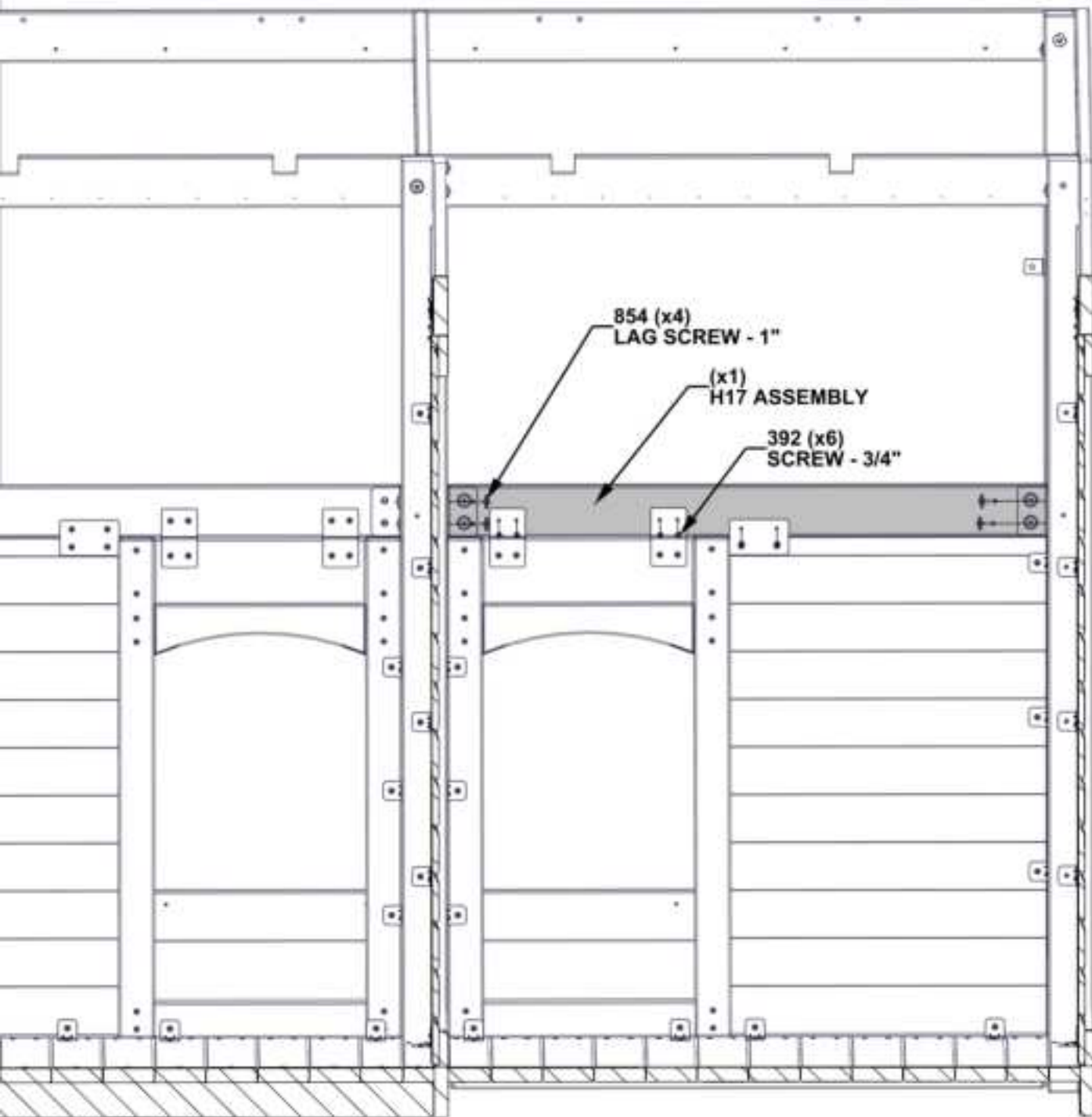

BACK SIDE IS HIDDEN FOR DETAIL

STEP 34A - ANIMAL ENCLOSURE ASSY

QTY	PART NUMBER	DESCRIPTION
4	H100630	WASHER FLAT 8x19 BLK
4	H100479	NUT LOCK 5/16 BLK
4	H100468	BOLT WH 5/16x1 BLK
4	H100198	WASHER LOCK EXT 8x19



A4M02606 JOIST HANGER 90°
(x2)

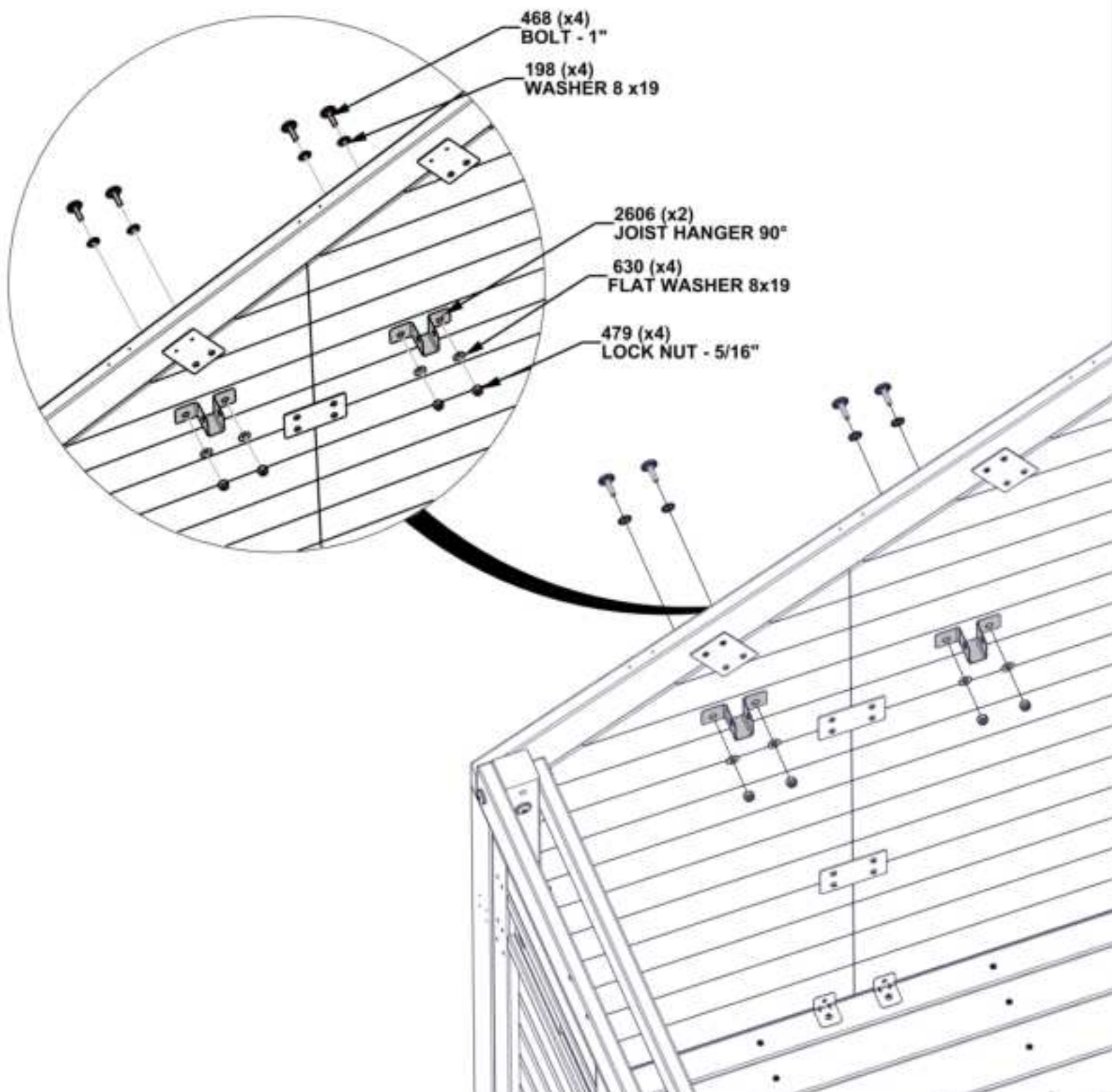

STEP 34B - ANIMAL ENCLOSURE ASSY

QTY	PART NUMBER	DESCRIPTION
4	H100630	WASHER FLAT 8x19 BLK
4	H100479	NUT LOCK 5/16 BLK
4	H100468	BOLT WH 5/16x1 BLK
4	H100198	WASHER LOCK EXT 8x19

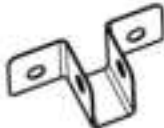

A4M02608 JOIST HANGER 90°
(x2)

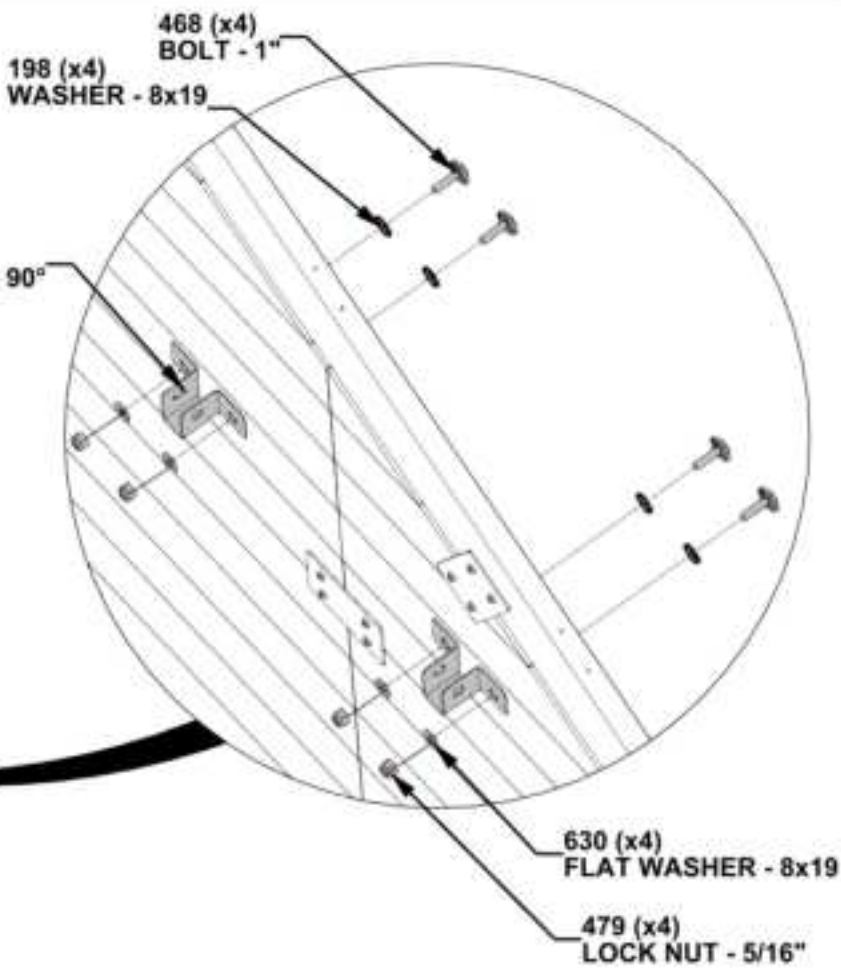
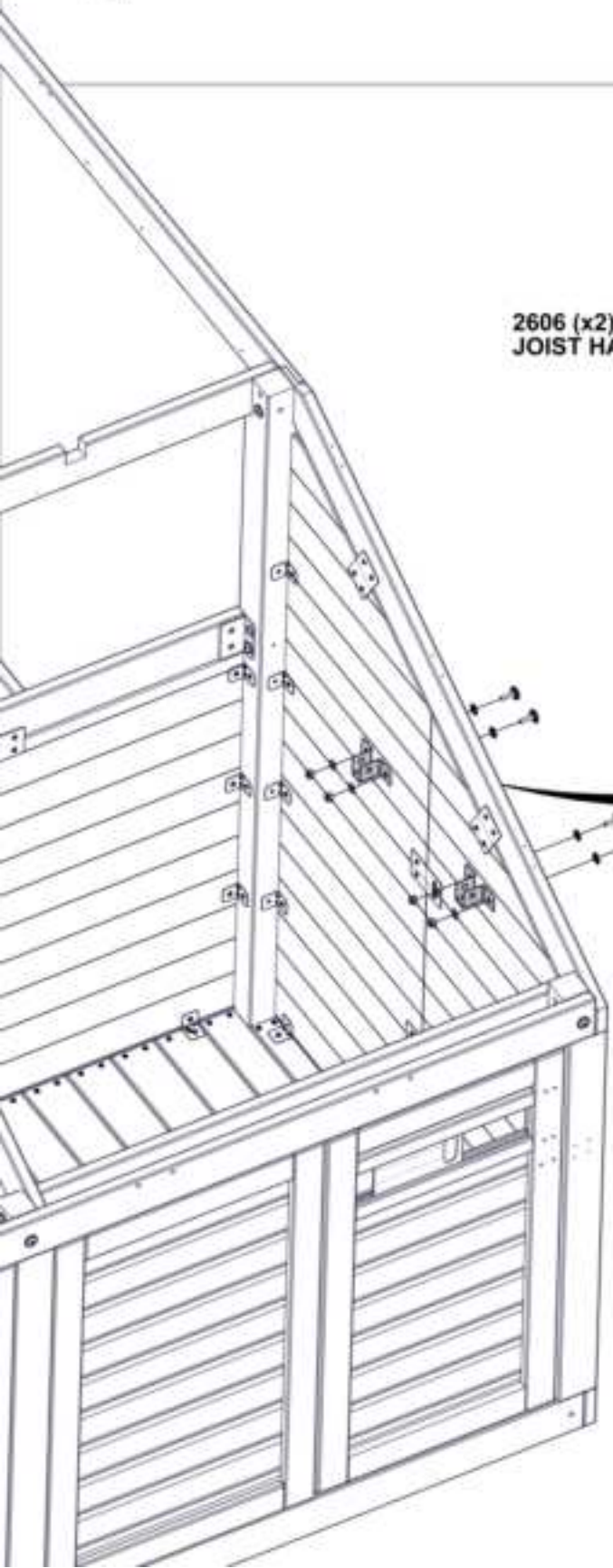

STEP 34C - ANIMAL ENCLOSURE ASSY

QTY	PART NUMBER	DESCRIPTION
4	H100630	WASHER FLAT 8x19 BLK
4	H100479	NUT LOCK 5/16 BLK
4	H100468	BOLT WH 5/16x1 BLK

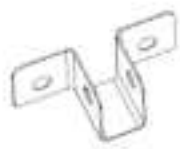

A4M02606 JOIST HANGER 90°
(x4)

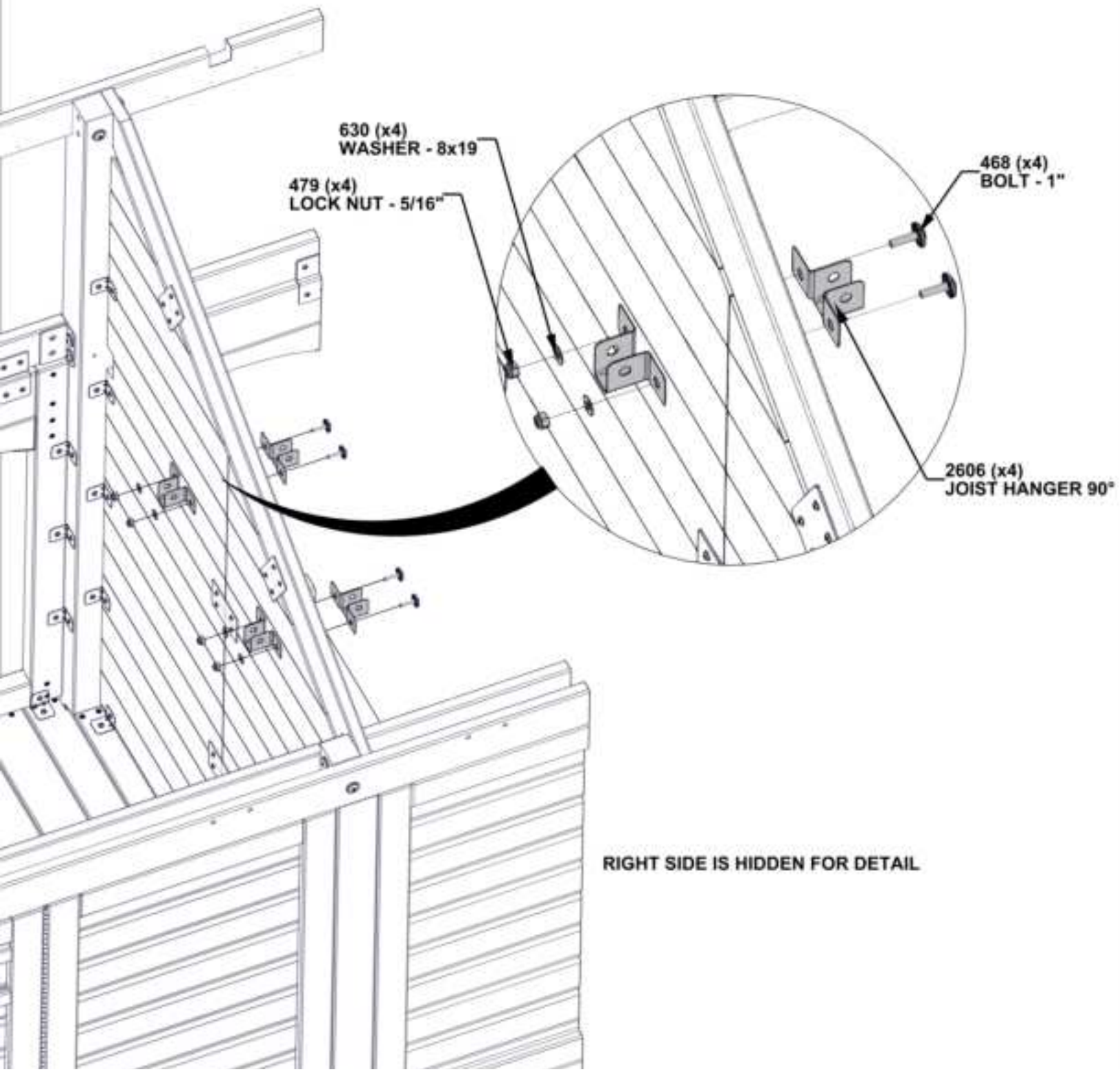

STEP 35A- ANIMAL ENCLOSURE ASSY



J13 FLOOR JOIST - W4L22550
(x1) 15/16"X2 3/8"X44 1/2" (24x60x1131)



J12 FLOOR JOIST - W4L22551
(x2) 15/16"X2 3/8"X42 7/16" (24x60x1078)

QTY	PART NUMBER	DESCRIPTION
4	H100663	BOLT WH 5/16x3/4 BLK
4	H100469	NUT BARREL WH 5/16X5/8 BLK
1	H100458	LAG SCREW WH 5/16x2 BLK
1	H100198	WASHER LOCK EXT 8x19

FRONT IS HIDDEN FOR DETAIL

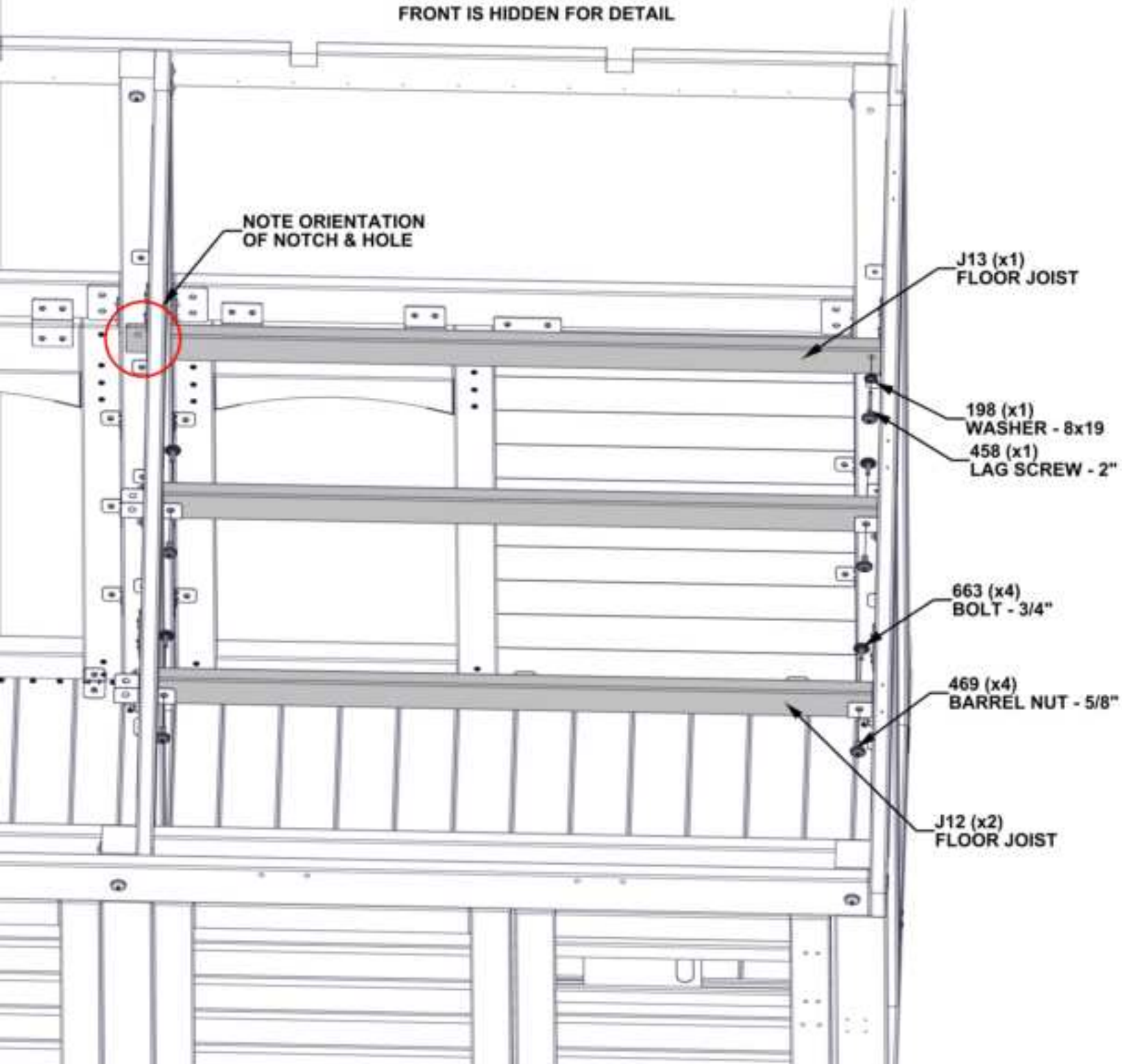

STEP 35B - ANIMAL ENCLOSURE ASSY

QTY	PART NUMBER	DESCRIPTION
4	H100663	BOLT WH 5/16x3/4 BLK
4	H100469	NUT BARREL WH 5/16X5/8 BLK
2	H100458	LAG SCREW WH 5/16x2 BLK
2	H100198	WASHER LOCK EXT 8x19



J5 FLOOR JOIST - W4L22543
(x1) 15/16"X2 3/8"X43 11/16" (24x60x1110)



J6 FLOOR JOIST - W4L22544
(x2) 15/16"X2 3/8"X43 11/16" (24x60x1109)

FRONT IS HIDDEN FOR DETAIL

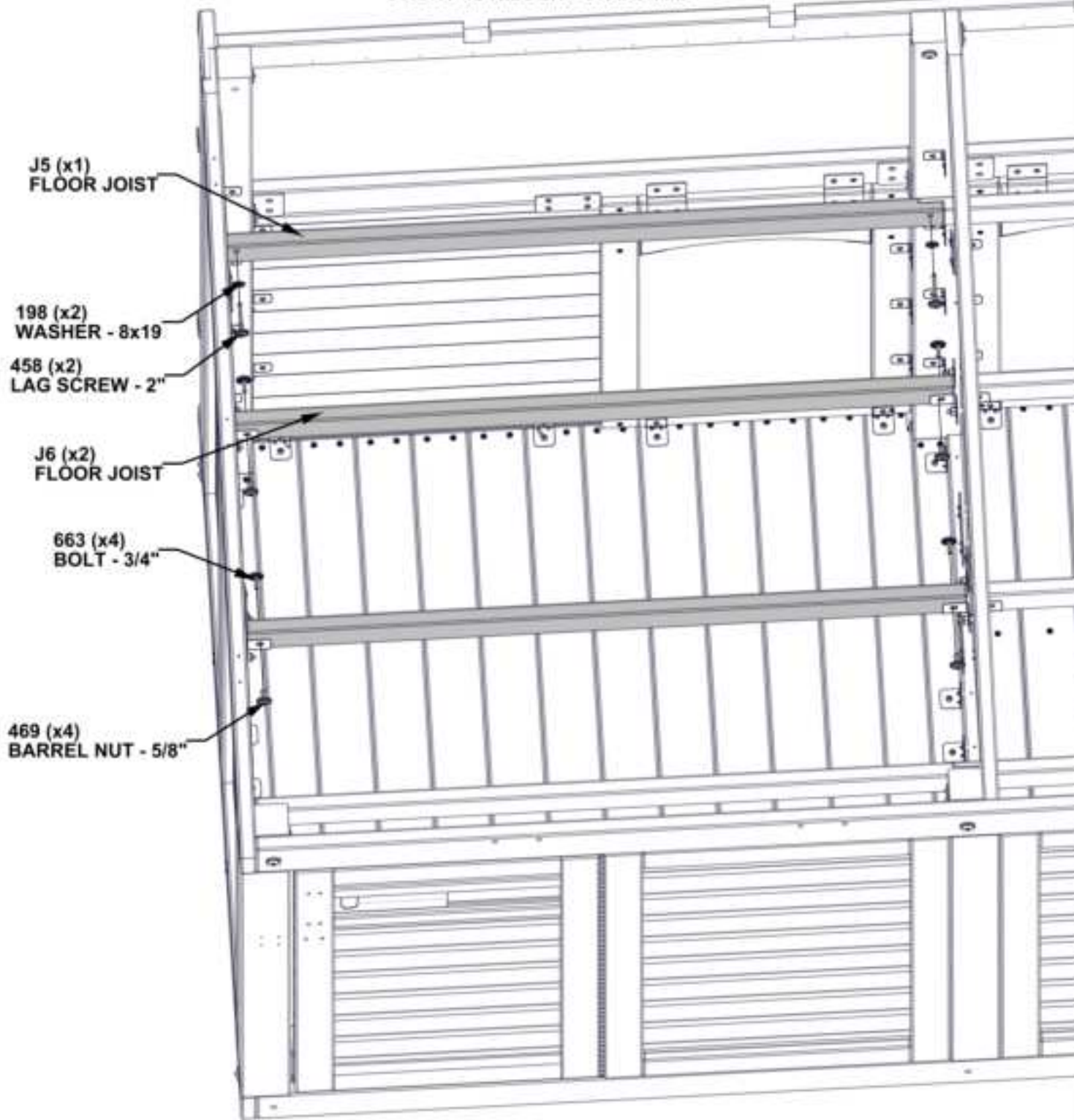

STEP 36A -ANIMAL ENCLOSURE ASSY

QTY	PART NUMBER	DESCRIPTION
74	H100387	SCREW PFH 8x1 1/4 BLK



M1 FLOORBOARD - W4L22547
(x1) 5/8"x3 3/8"x42 3/16" (16x86x1072)



L2 FLOOR BOARD - W4L22554
(x1) 5/8"x4 1/4"x42 3/16" (16x108x1072)



M3 FLOOR BOARD - W4L22549
(x4) 5/8"x3 3/8"x40 3/16" (16x86x1021)



N2 FLOOR BOARD - W4L22546
(x2) 5/8"x1 7/8"x38 1/8" (16x48x968)

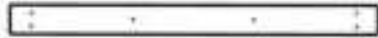

M4 FLOOR BOARD - W4L22548
(x2) 5/8"x3 3/8"x42 3/16" (16x86x1072)



Y1 FLOOR BOARD - W4L22553
(x3) 5/8"x3 13/16"x42 3/16" (16x97x1072)

- SPACE BOARDS EVENLY

BACK SIDE HIDDEN FOR DETAIL

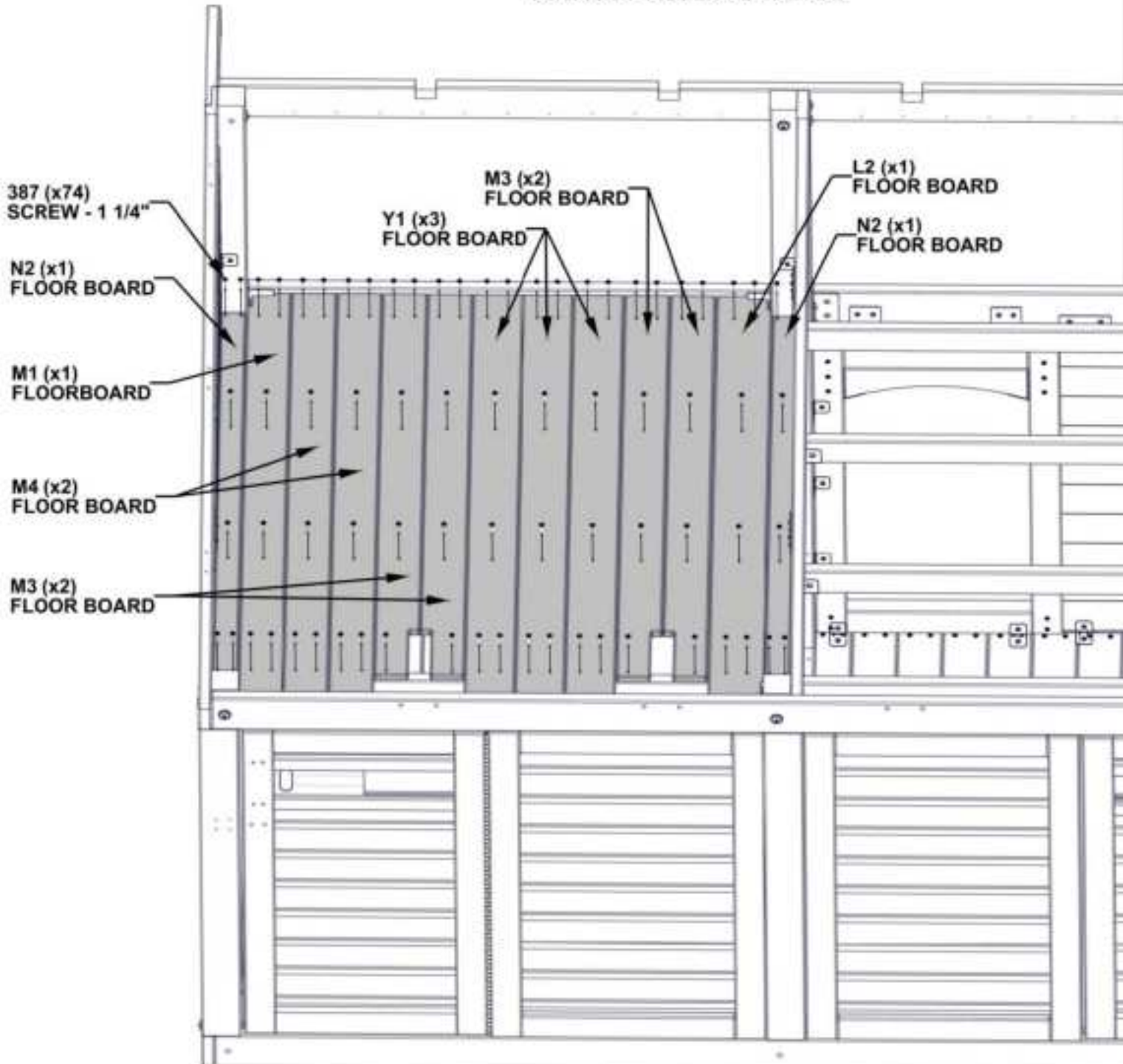

STEP 36B - ANIMAL ENCLOSURE ASSY

QTY	PART NUMBER	DESCRIPTION
68	H100387	SCREW PFH 8x1 1/4 BLK



M1 FLOORBOARD - W4L22547
(x1) 5/8"x3 3/8"x42 3/16" (16x86x1072)

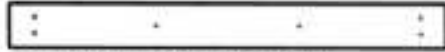

L1 FLOOR BOARD - W4L22552
(x1) 5/8"x4 5/16"x42 3/16" (16x109x1072)

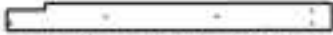

M3 FLOOR BOARD - W4L22549
(x4) 5/8"x3 3/8"x40 3/16" (16x86x1021)



N2 FLOOR BOARD - W4L22546
(x1) 5/8"x1 7/8"x38 1/8" (16x48x968)

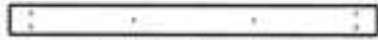

M4 FLOOR BOARD - W4L22548
(x2) 5/8"x3 3/8"x42 3/16" (16x86x1072)



Y1 FLOOR BOARD - W4L22553
(x3) 5/8"x3 13/16"x42 3/16" (16x97x1072)

- SPACE BOARDS EVENLY

BACK SIDE HIDDEN FOR DETAIL

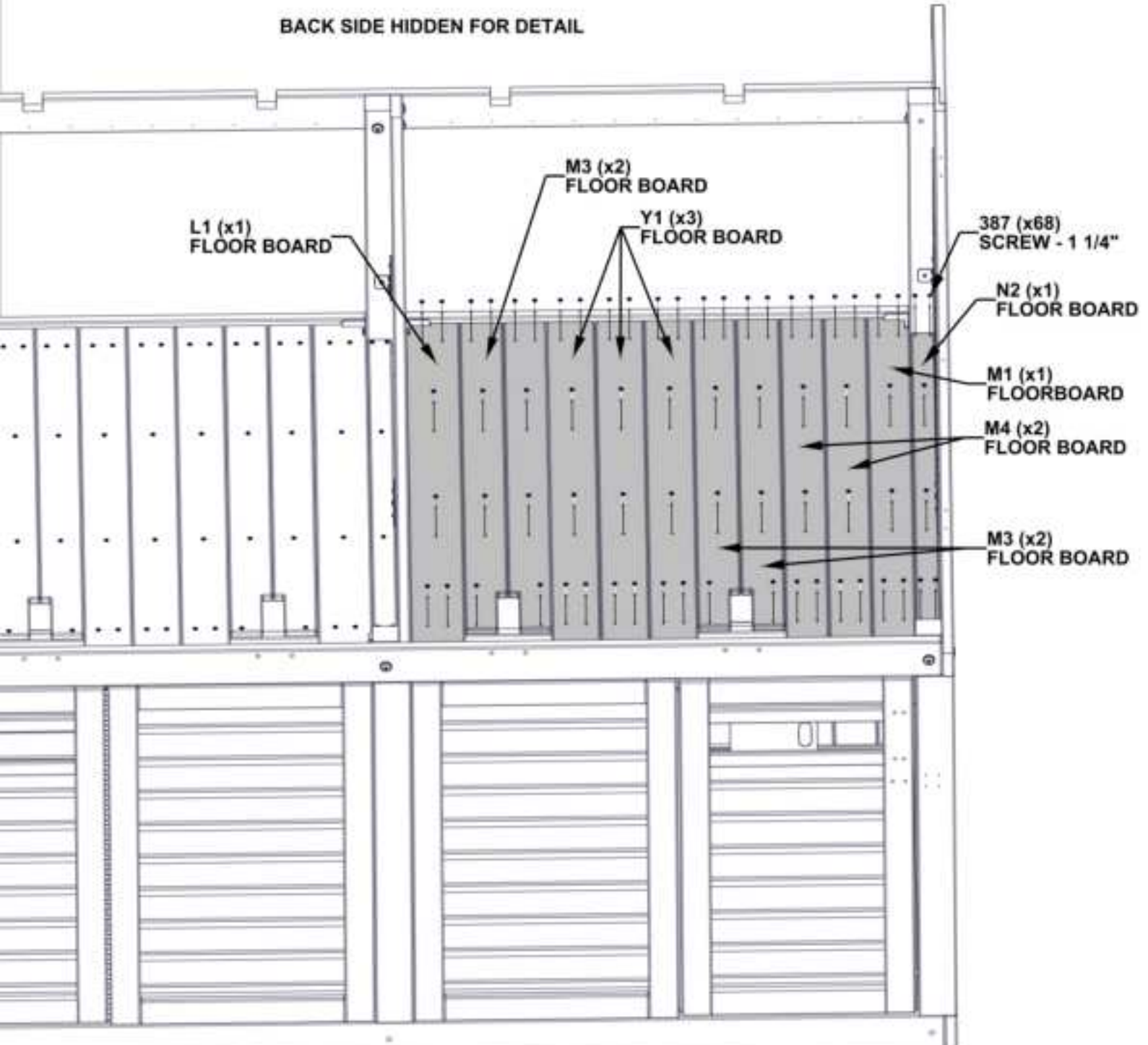

STEP 37A - DP3 ASSEMBLY

QTY	PART NUMBER	DESCRIPTION
11	H100627	SCREW PFH 6x3/4 BLK

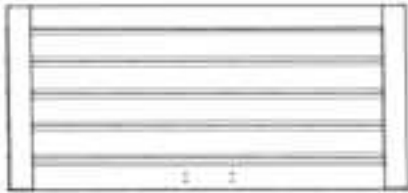

DP3 STORAGE DOOR - W2A04949
(x1) 1 1/16"X18 1/4"X39 7/16" (27x464x1003)



A4M02726 HINGE 832mm
(x1)

- USE PILOT HOLES TO ALIGN HINGE

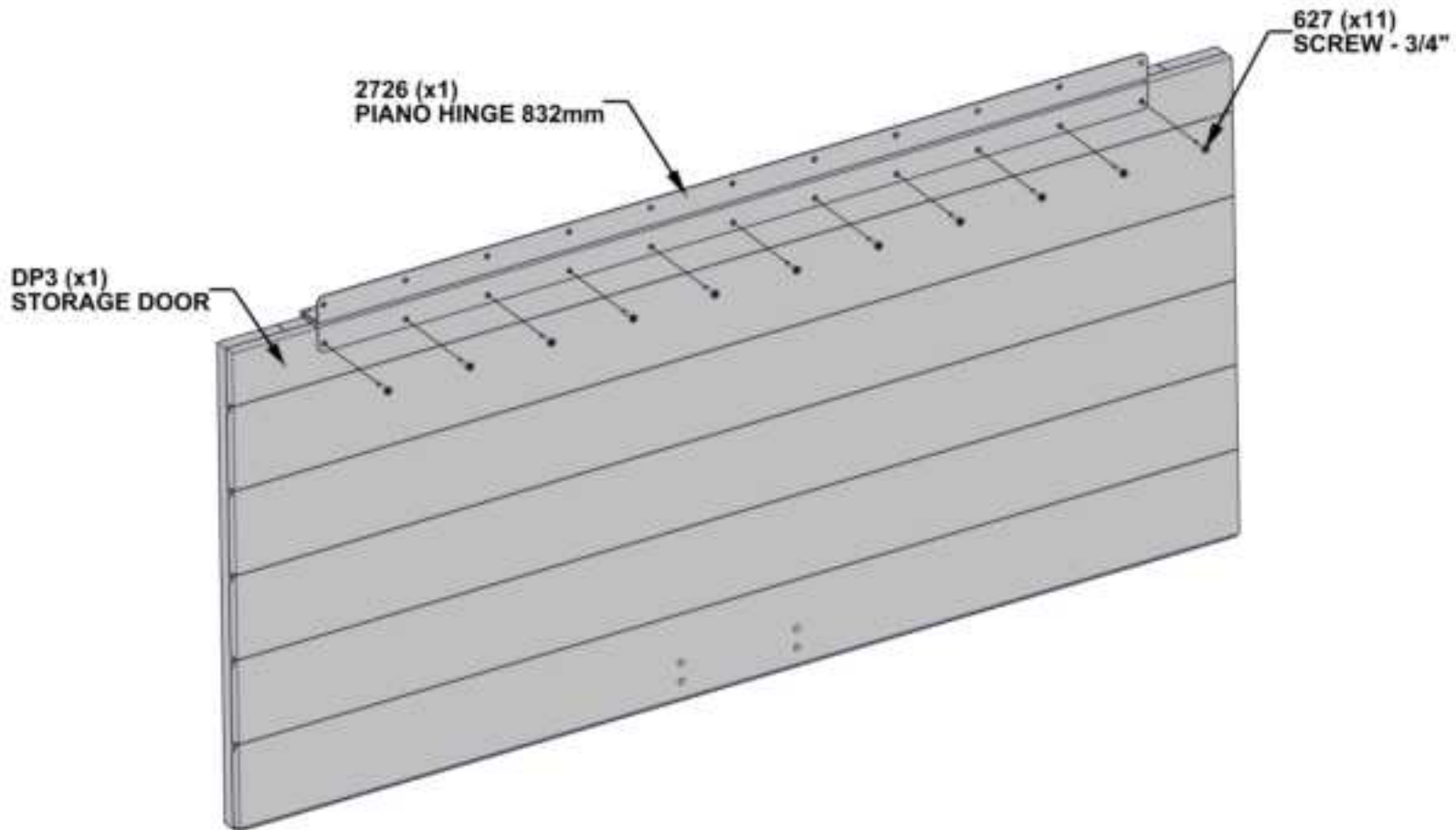

STEP 37B - ANIMAL ENCLOSURE ASSY

QTY	PART NUMBER	DESCRIPTION
11	H100627	SCREW PFH 6x3/4 BLK



DP3 ASSEMBLY
(x1) (FROM STEP 37A)

- USE PILOT HOLES TO ALIGN SCREWS

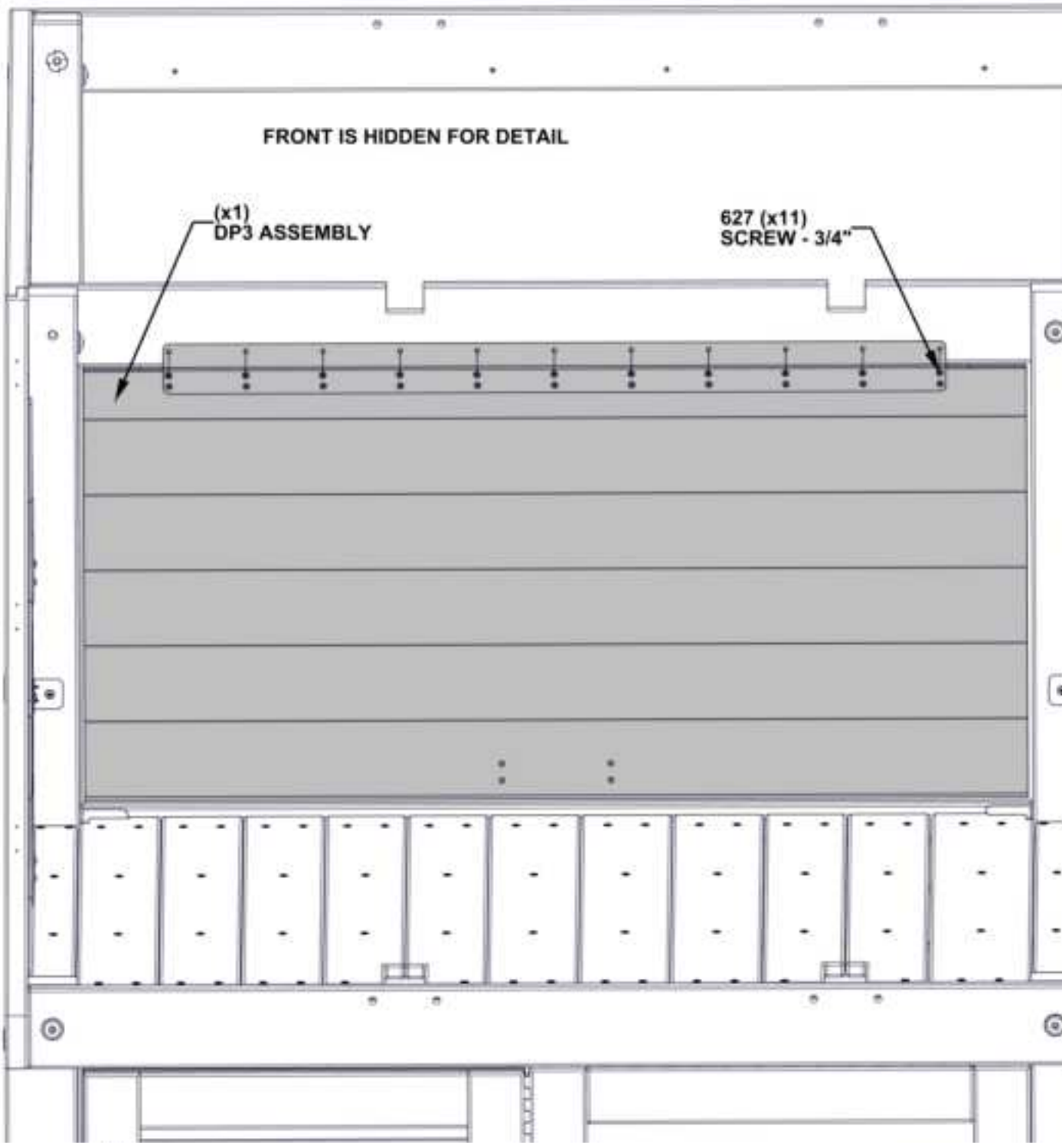

STEP 38 - ANIMAL ENCLOSURE ASSY

QTY	PART NUMBER	DESCRIPTION
4	H100382	SCREW PFH 8x1 3/4 BLK



OR01 CLEAT - W4L22542
(x1) 1 3/16"x2 3/8"x6 7/8" (30x60x175)

- PREDRILL 1/8" [3mm]
PILOT HOLES FOR THE
ATTACHMENT OF HARDWARE.

200 (x4)
SCREW - 1 1/2"

**BOARD SITS FLUSH
AGAINST DOOR DP3**

OR01 (x1)
CLEAT

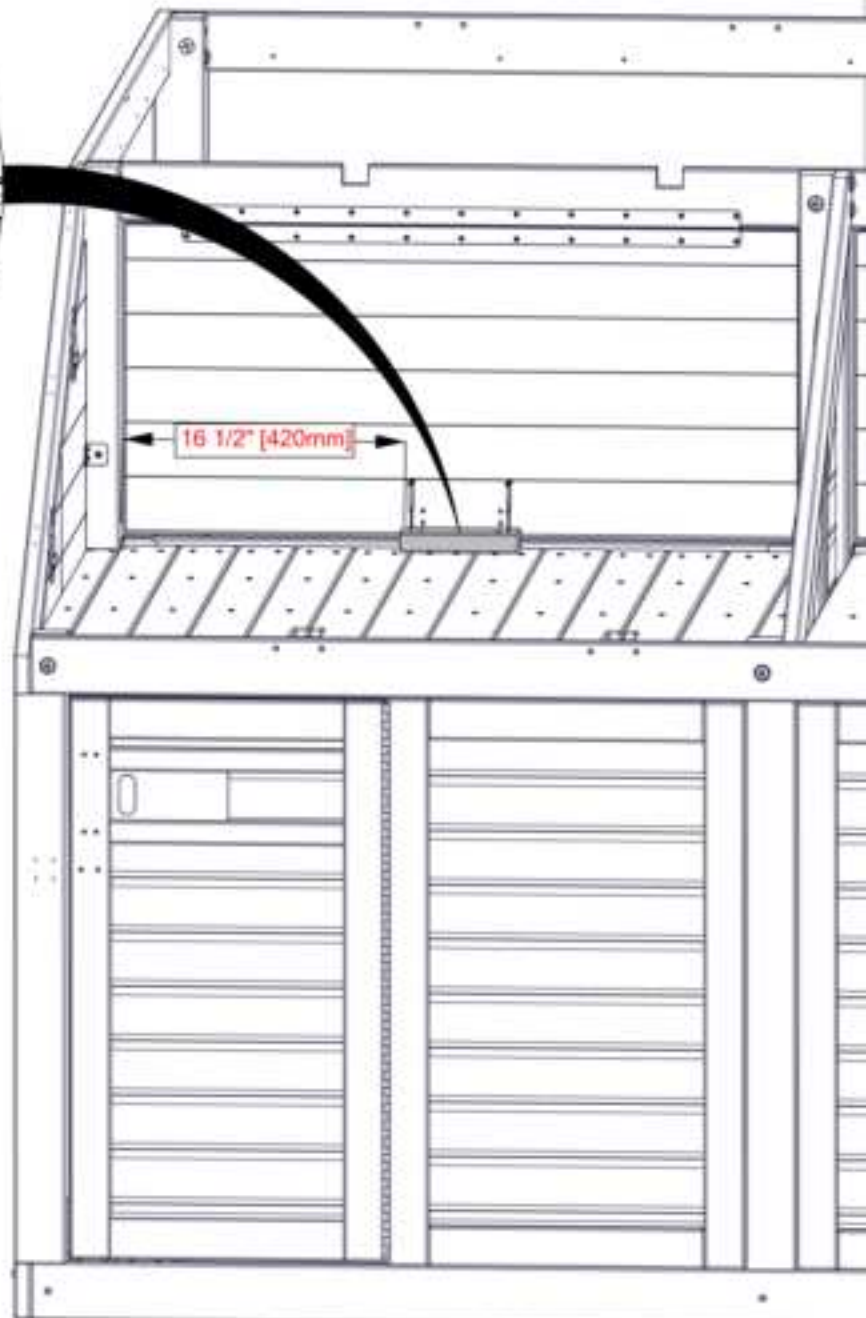
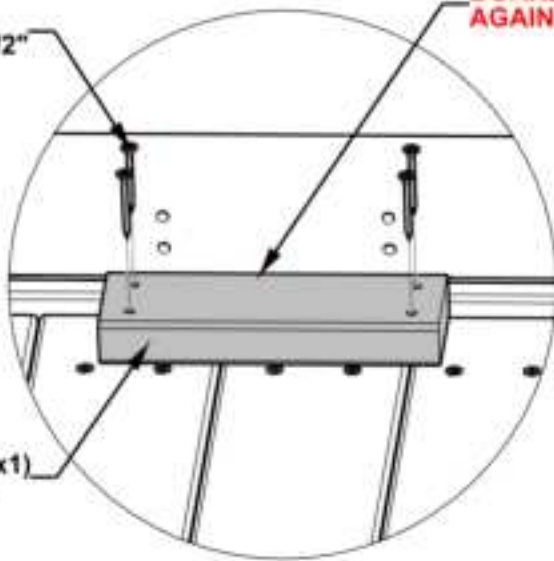

STEP 39 - ANIMAL ENCLOSURE ASSY

QTY	PART NUMBER	DESCRIPTION
2	H100395	SCREW PFH 8x3/4 BLK
3	H100202	SCREW PWH 8x5/8 BLK



A4M02627 SCREW ON HASP LOCK (x1)

- TIP INSTALL BOTTOM PART OF HASP LOCK FIRST

USE BOTTOM PART OF HASP LOCK TO ALIGN TOP PART OF HASP LOCK

395 (x2)
SCREW - 3/4"

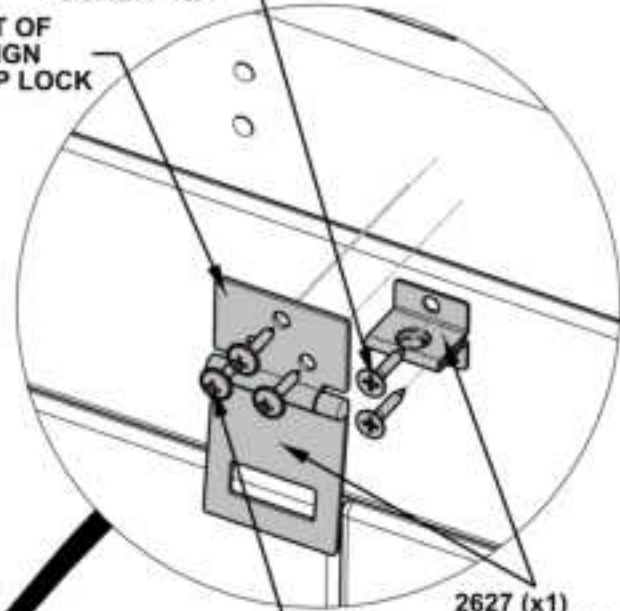

2627 (x1)
SCREW ON
HASP LOCK
ASSEMBLY

202 (x3)
SCREW - 5/8"

19 5/8" [498mm]

2 1/4" [57mm]

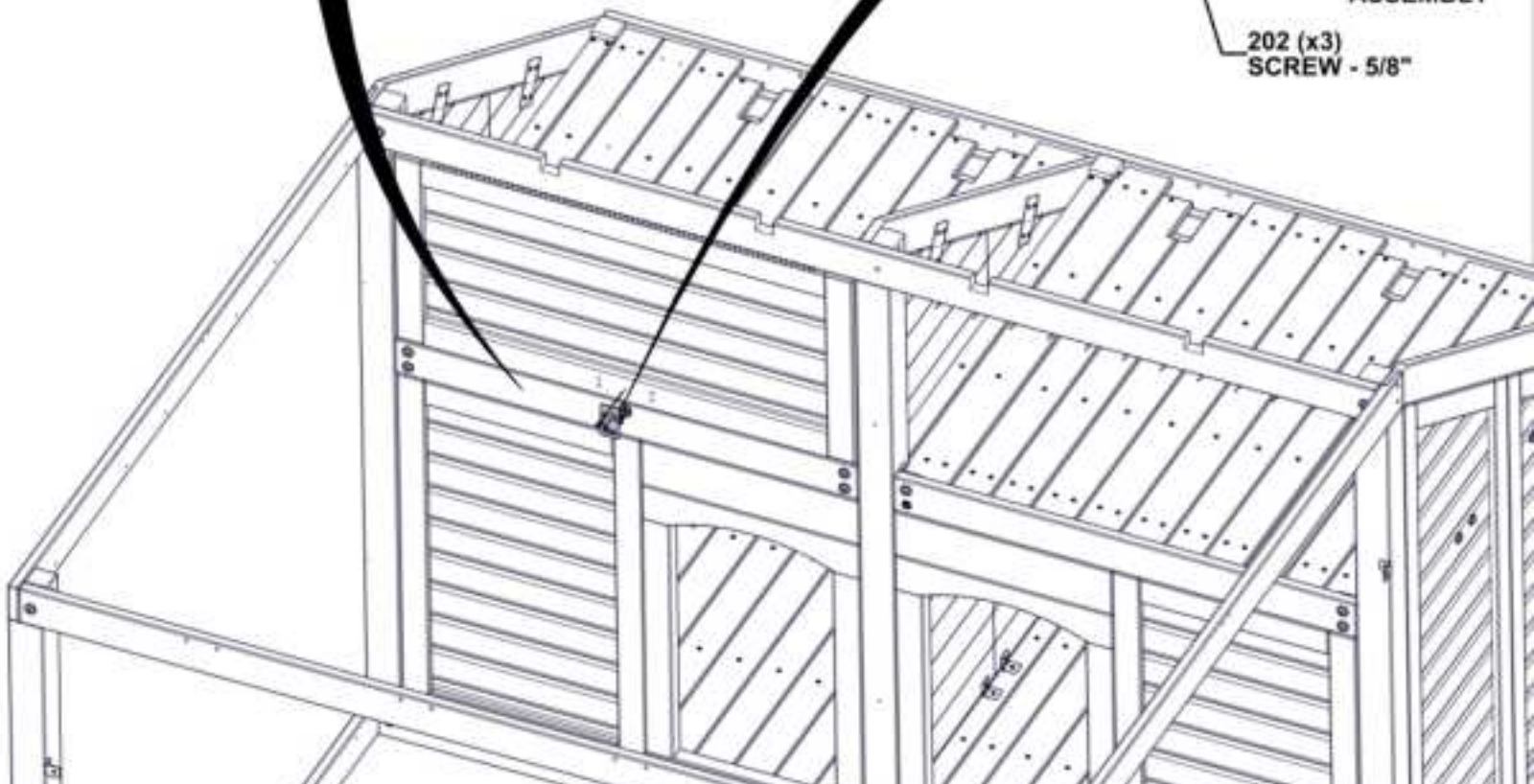

STEP 40 - ANIMAL ENCLOSURE ASSY

QTY	PART NUMBER	DESCRIPTION
4	H100806	SCREW POH-MS 8/32x1 1/8" BLK
4	H100804	T-NUT 8/32 BLK

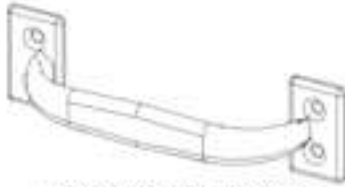

A4M00559 PULL HANDLE
(x1)

- INSERT T-NUTS FIRST

806 (x4)
SCREW - 1 1/8"

559 (x1)
PULL HANDLE

804 (x4)
TNUT 8-32

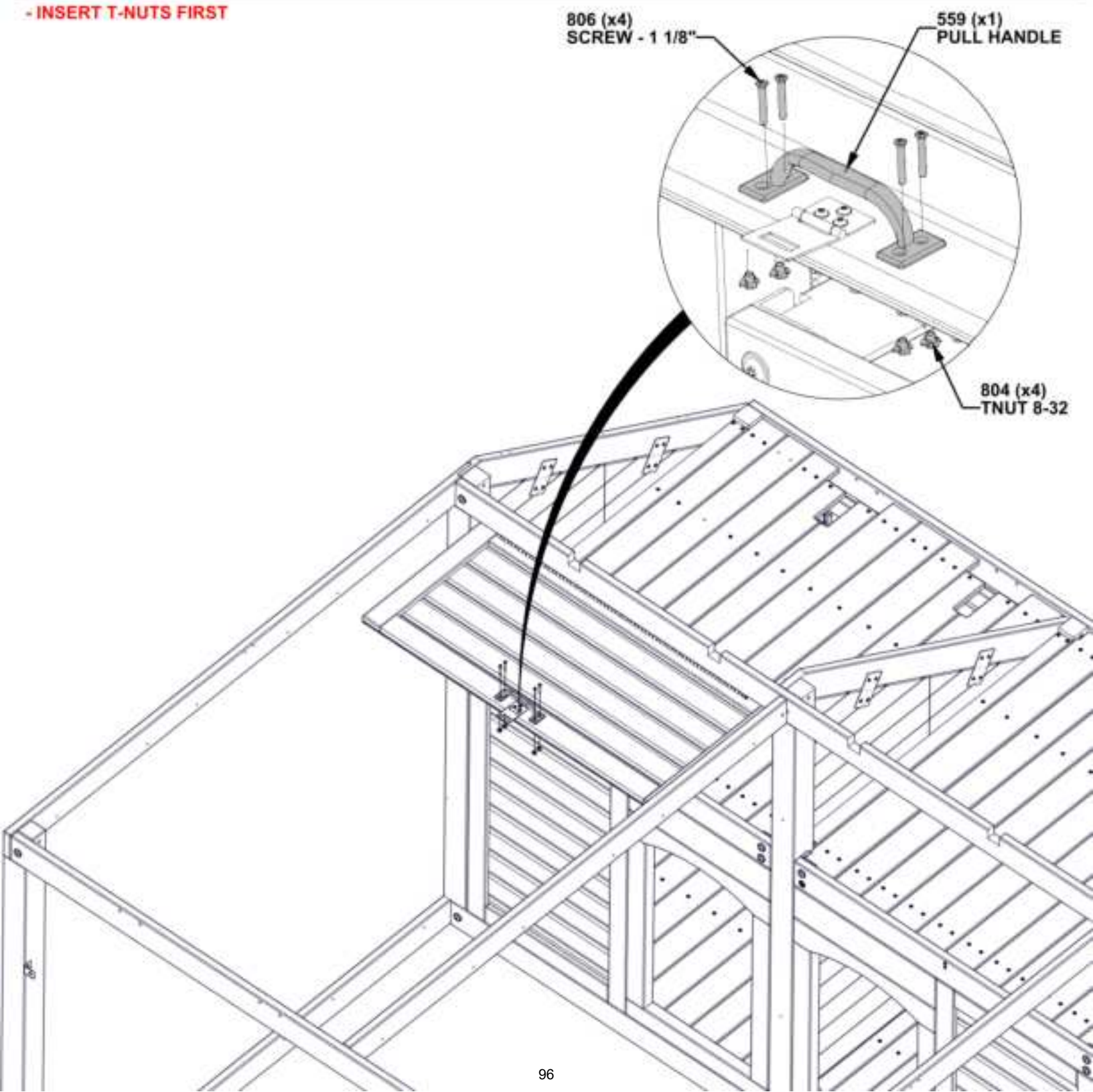

**REPEAT DOOR ASSEMBLY
STEPS 37A THROUGH 40**

CHOOSING A LOCATION FOR THE DOORS

- BEFORE PROCEEDING INSTALLING THE WIRE PANELS, PLEASE DETERMINE THE PLACEMENT OF THE DOORS.
- IF YOU CHOOSE A POSITION OTHER THAN POSITION 1, YOU WILL SIMPLY SWAP WITH THE PANEL IN THAT POSITION.
- TO AVOID DAMAGING THE PANELS, DO NOT OVERTIGHTEN HARDWARE.
- DOORS CAN NOT FLIP DUE TO DOOR LATCH.

POSITION 1



POSITION 2



POSITION 3



POSITION 4



POSITION 5



STEP 41A - RIGHT SIDE

QTY	PART NUMBER	DESCRIPTION
2	H100486	BOLT WH 1/4x5/8 BLK
4	H100460	LAG SCREW WH 1/4x1 BLK
2	H100404	NUT BARREL WH 1/4X5/8 BLK

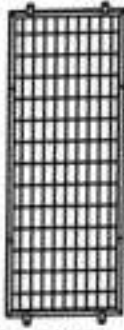

MP01 METAL PANEL - A4M02614
(x1)

- USE PILOT HOLES TO ALIGN CAGE HOLES

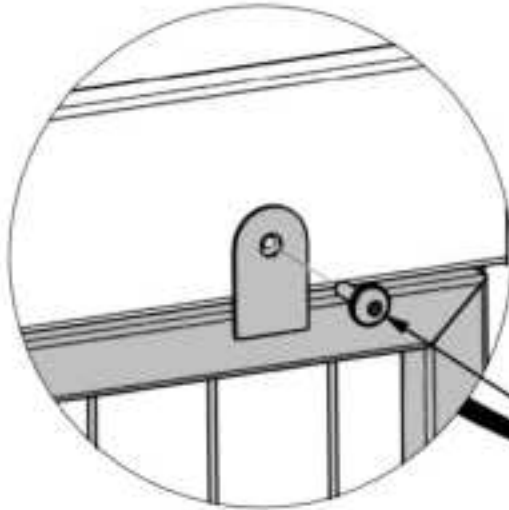

460 (x4)
LAG SCREW - 1"

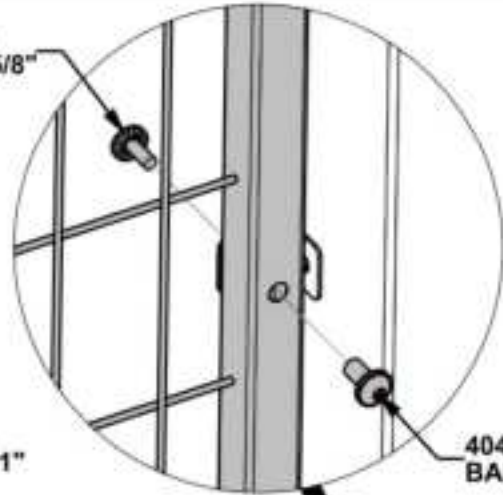

486 (x2)
BOLT - 5/8"

404 (x2)
BARREL NUT - 5/8"

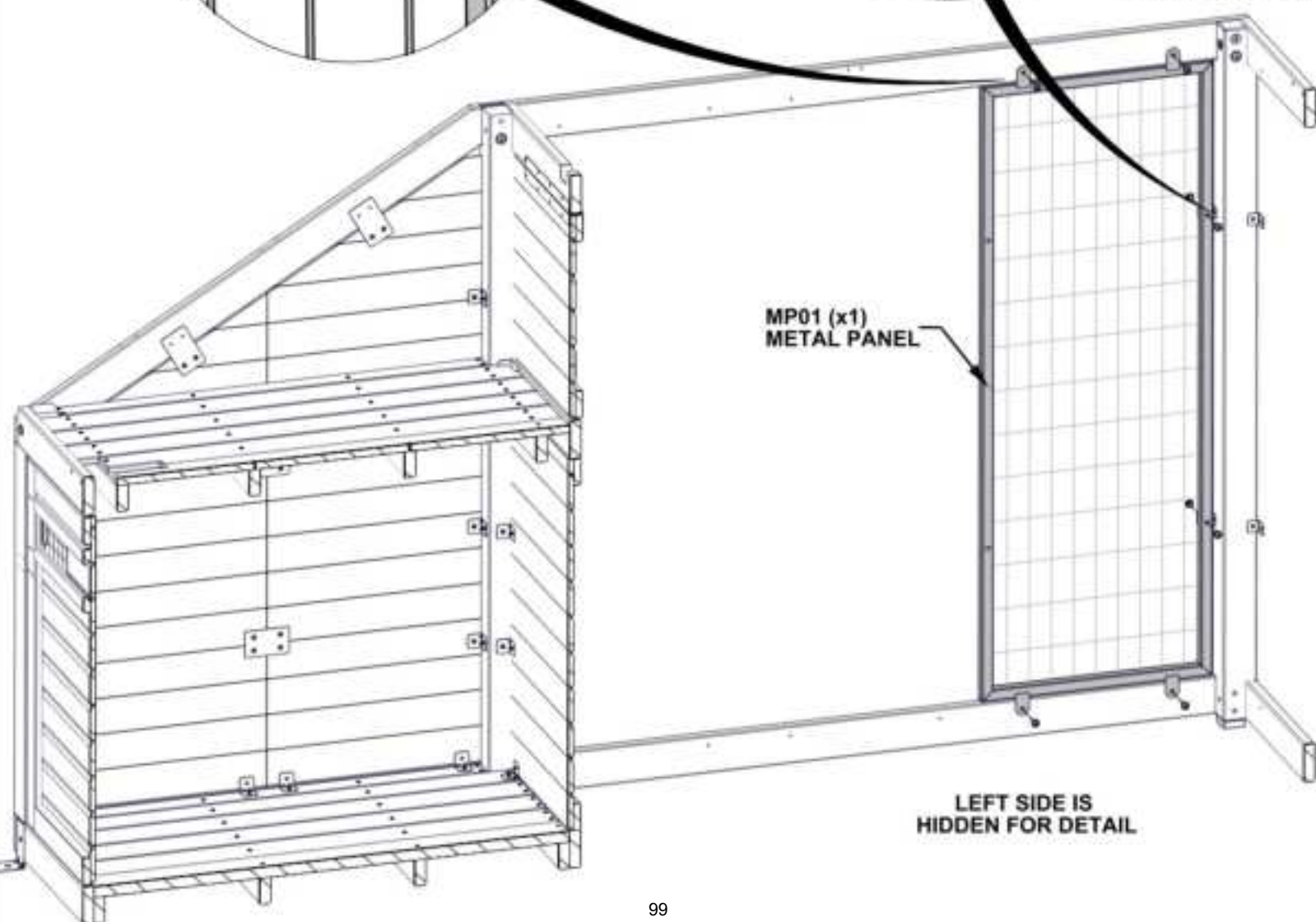

MP01 (x1)
METAL PANEL

LEFT SIDE IS
HIDDEN FOR DETAIL

STEP 41B - RIGHT SIDE

QTY	PART NUMBER	DESCRIPTION
2	H100486	BOLT WH 1/4x5/8 BLK
4	H100460	LAG SCREW WH 1/4x1 BLK
2	H100404	NUT BARREL WH 1/4X5/8 BLK

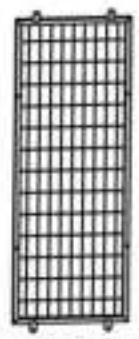

MP01 METAL PANEL - A4M02614 (x1)

- USE PILOT HOLES TO ALIGN HOLES

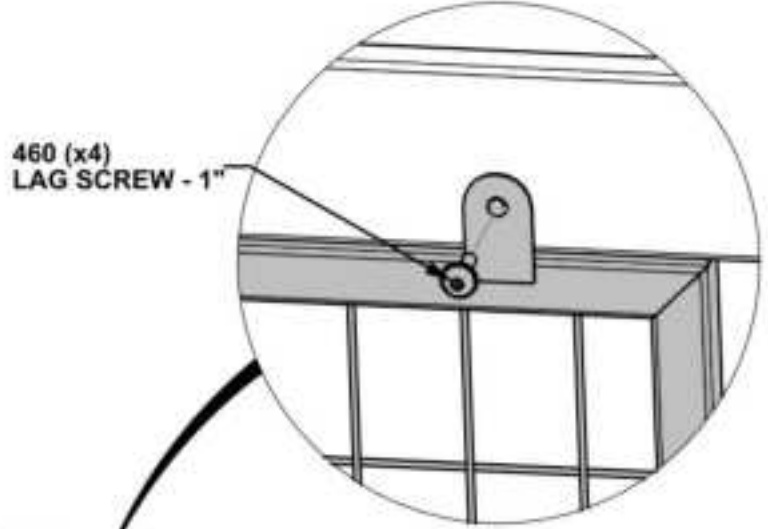
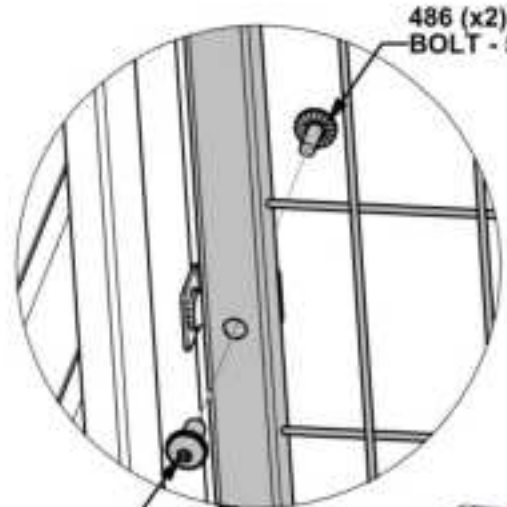

404 (x2) BARREL NUT - 5/8"

MP01 (x1) METAL PANEL

LEFT SIDE IS HIDDEN FOR DETAIL

STEP 41C - RIGHT SIDE

QTY	PART NUMBER	DESCRIPTION
4	H100460	LAG SCREW WH 1/4x1 BLK

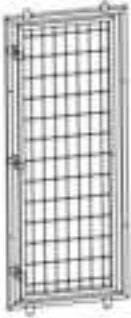

MP04 METAL DOOR PANEL ASSEMBLY - A4M06581
(x1)

- USE PILOT HOLES TO ALIGN HOLES

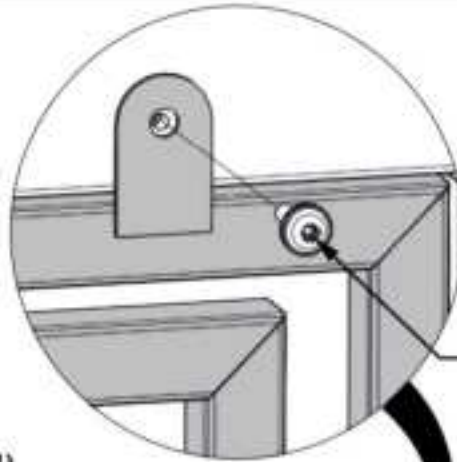

460 (x4)
LAG SCREW - 1"

MP04 (x1)
METAL DOOR
PANEL ASSEMBLY

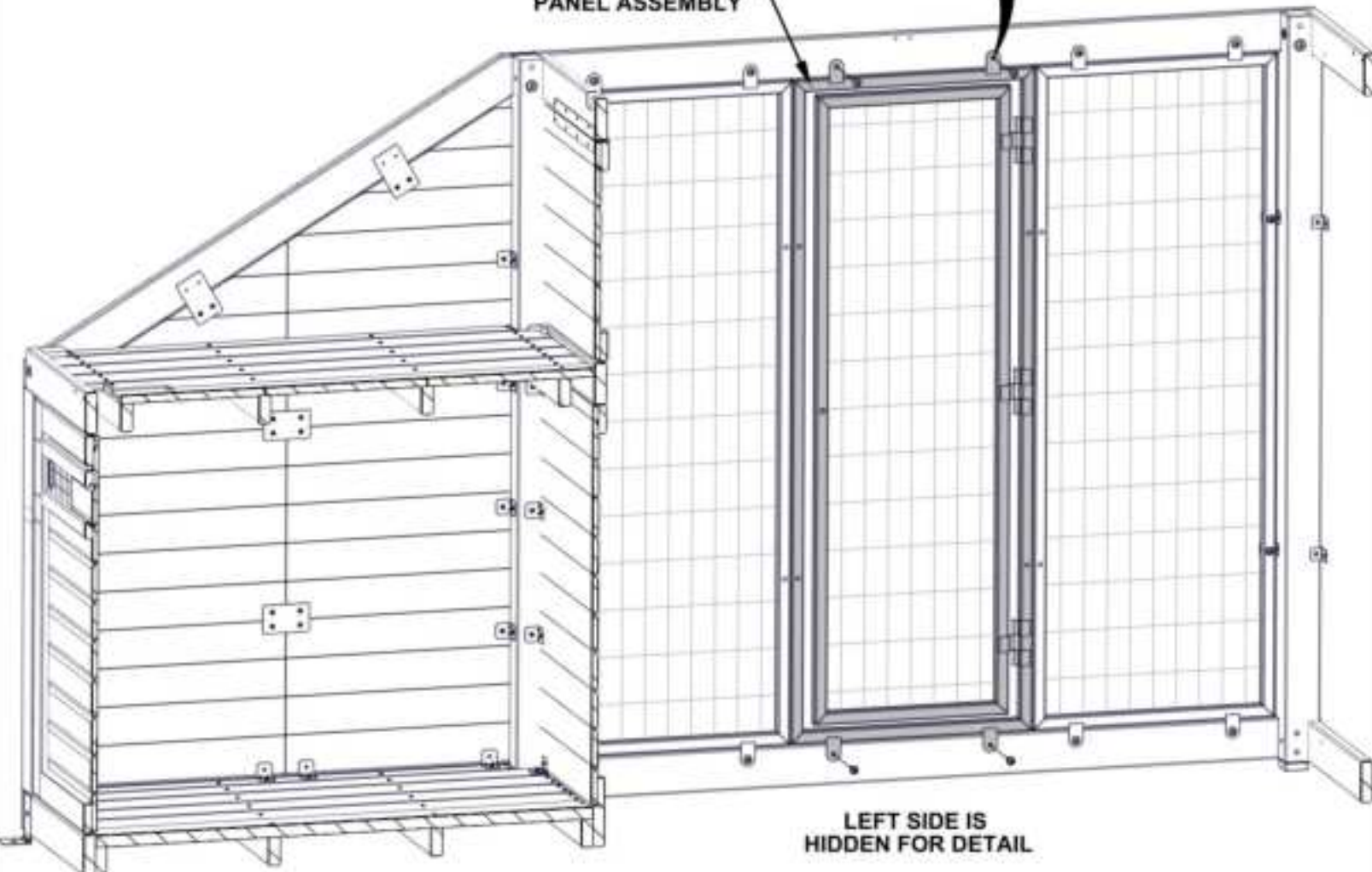

LEFT SIDE IS
HIDDEN FOR DETAIL

STEP 41D - RIGHT SIDE

QTY	PART NUMBER	DESCRIPTION
8	H100486	BOLT WH 1/4x5/8 BLK
8	H100404	NUT BARREL WH 1/4X5/8 BLK



A4M02616 METAL PANEL FLAT BRACKET
(x4)

- ALIGN BRACKETS WITH HOLES
- SQUARE BRACKETS BEFORE LOCKING HARDWARE

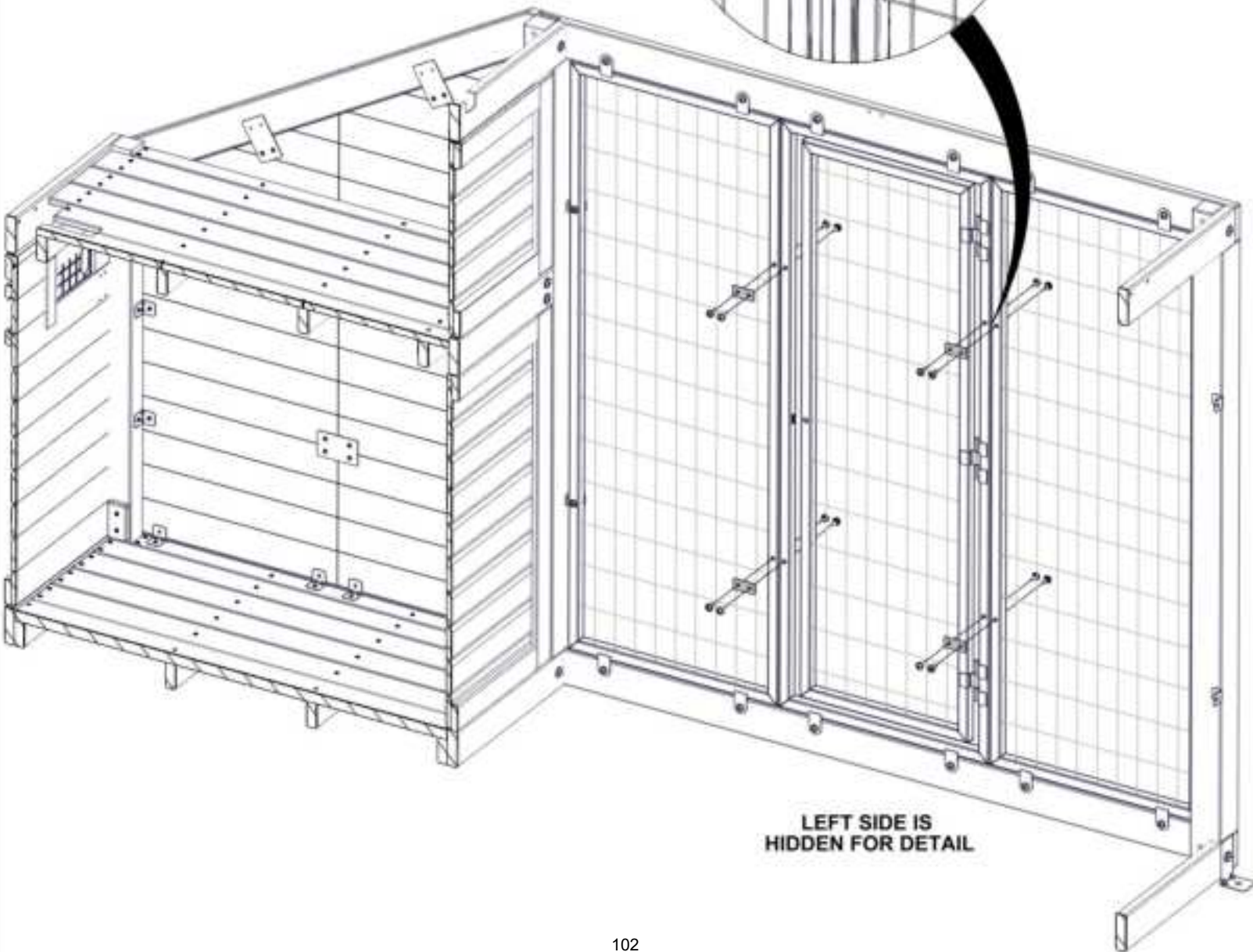
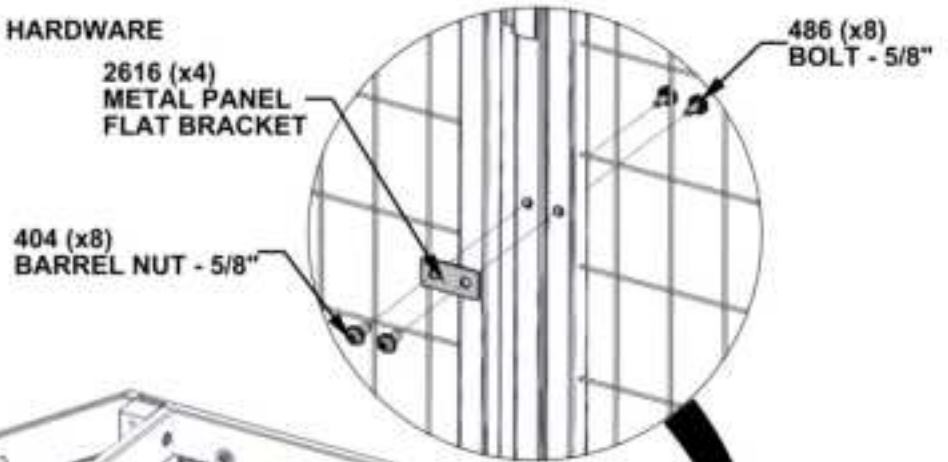

STEP 42A - FRONT SIDE

QTY	PART NUMBER	DESCRIPTION
2	H100486	BOLT WH 1/4x5/8 BLK
4	H100460	LAG SCREW WH 1/4x1 BLK
2	H100404	NUT BARREL WH 1/4X5/8 BLK

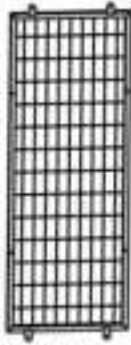

MP01 METAL PANEL - A4M02614
(x1)

- USE PILOT HOLES TO ALIGN HOLES

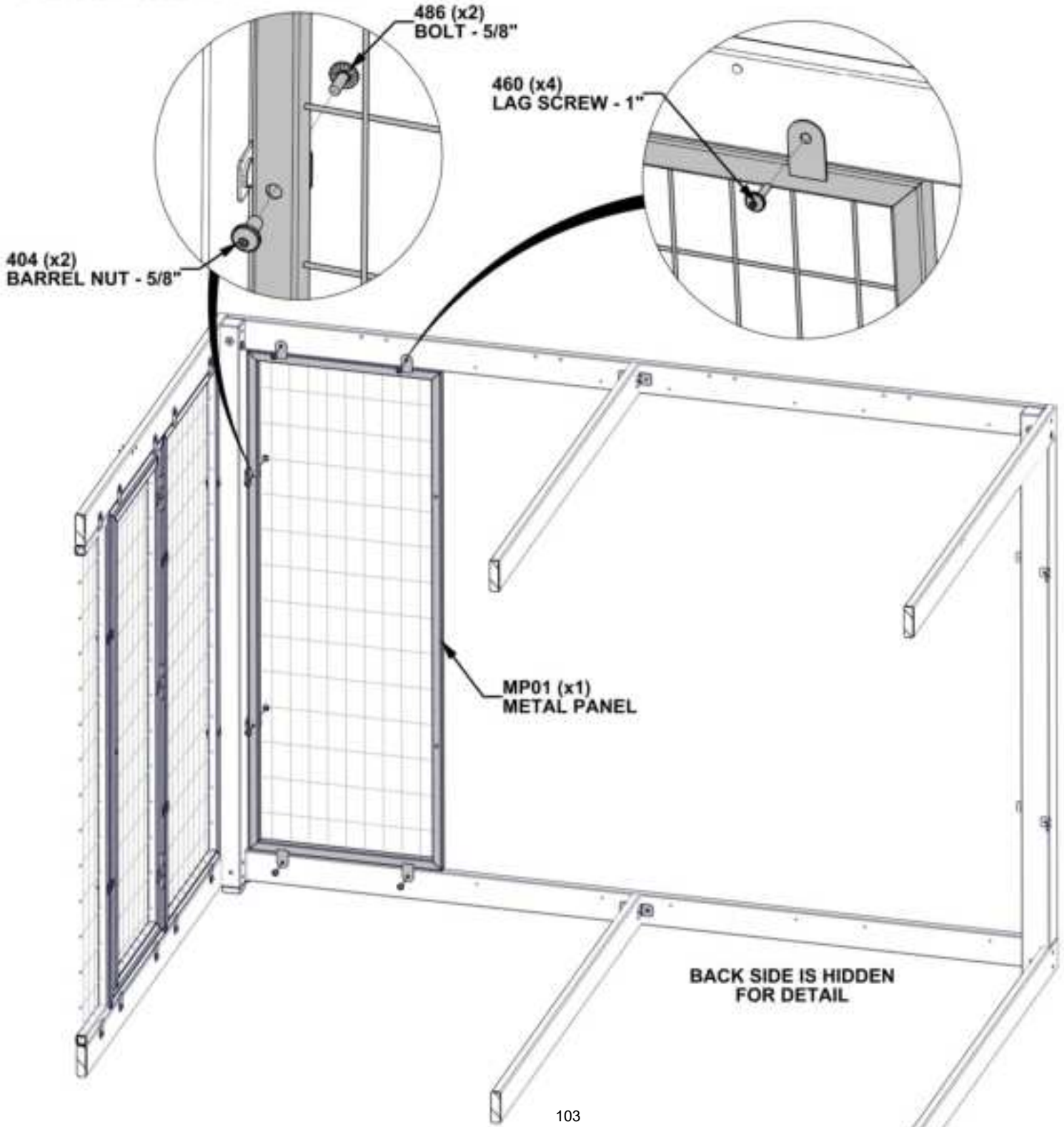

STEP 42B - FRONT SIDE

QTY	PART NUMBER	DESCRIPTION
2	H100486	BOLT WH 1/4x5/8 BLK
4	H100460	LAG SCREW WH 1/4x1 BLK
2	H100404	NUT BARREL WH 1/4X5/8 BLK

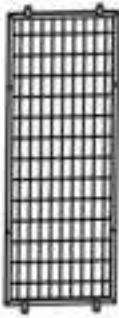

MP01 METAL PANEL - A4M02614
(x1)

- USE PILOT HOLES TO ALIGN HOLES

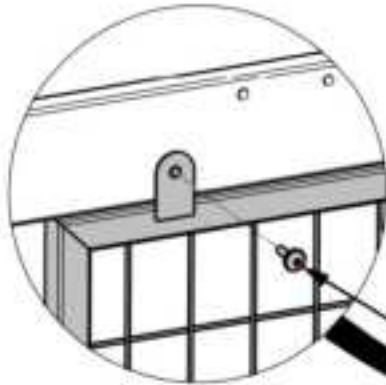

460 (x4)
LAG SCREW - 1"

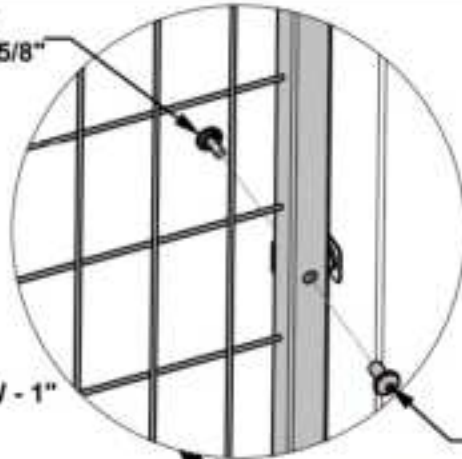

486 (x2)
BOLT - 5/8"

404 (x2)
BARREL NUT - 5/8"

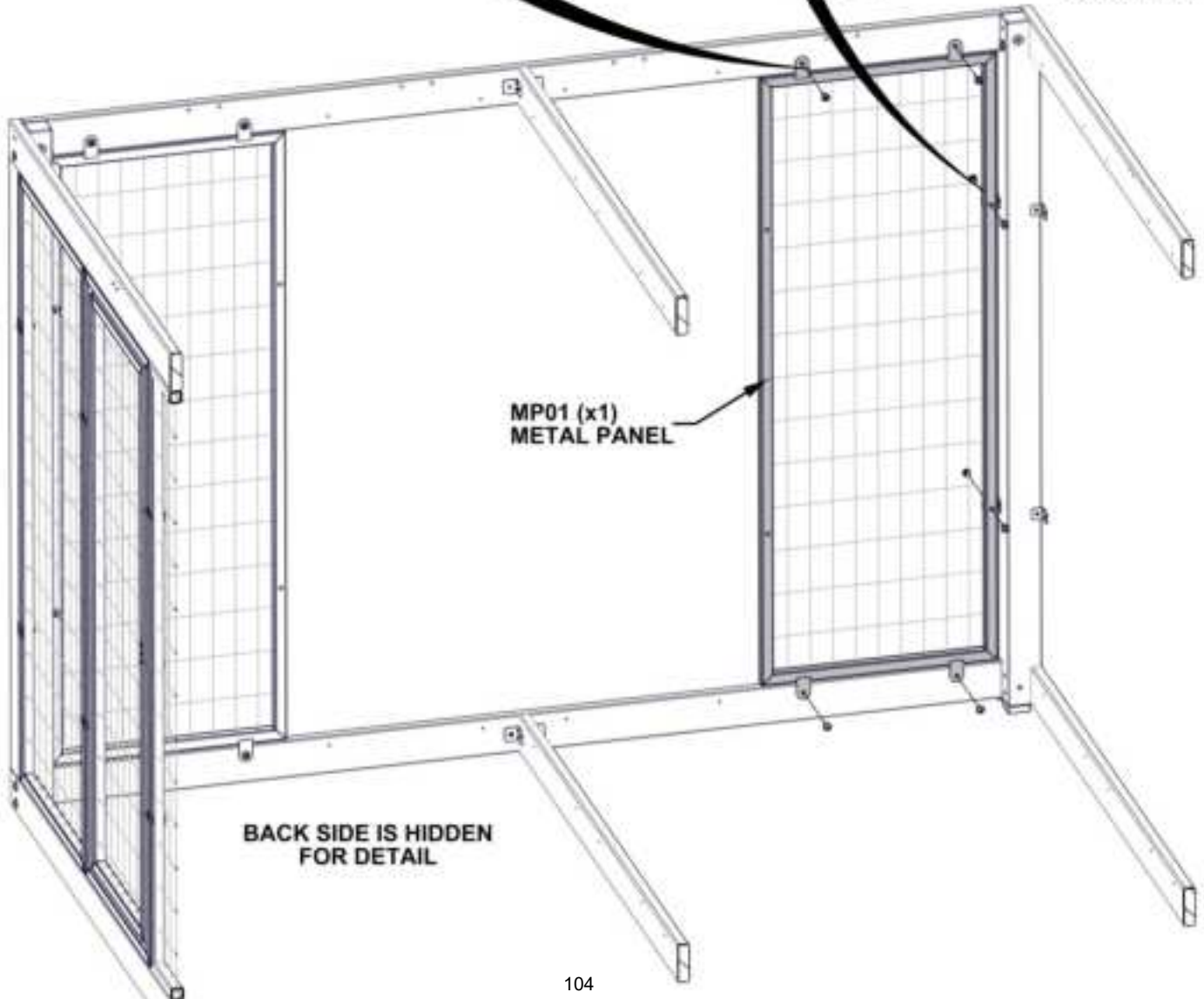

MP01 (x1)
METAL PANEL

BACK SIDE IS HIDDEN
FOR DETAIL

STEP 42C - FRONT SIDE

QTY	PART NUMBER	DESCRIPTION
4	H100460	LAG SCREW WH 1/4x1 BLK

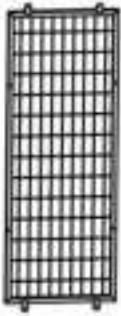

MP01 METAL PANEL - A4M02614
(x1)

- USE PILOT HOLES TO ALIGN HOLES

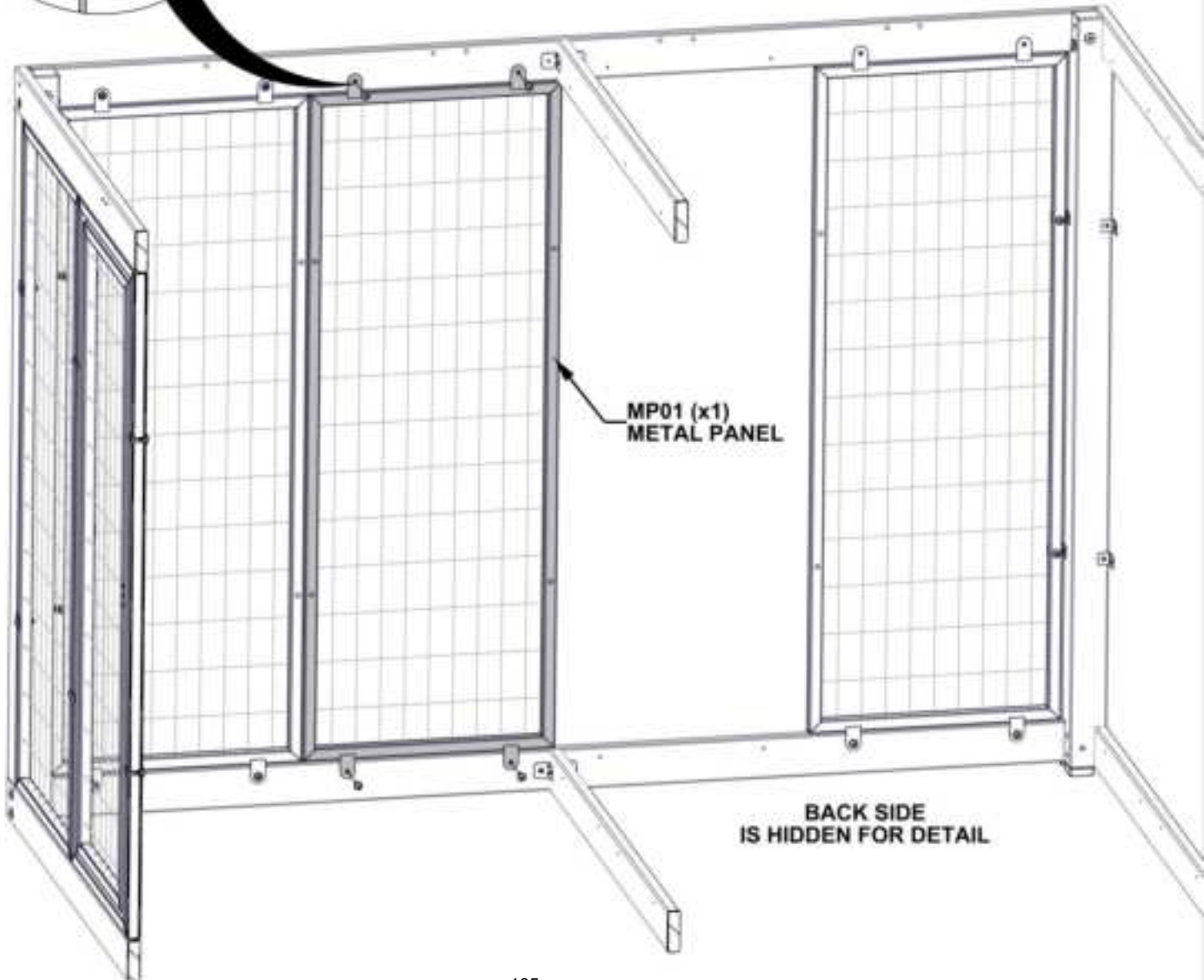
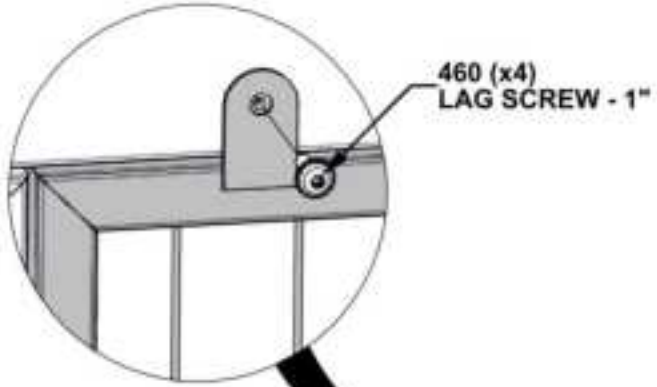

STEP 42D - FRONT SIDE

QTY	PART NUMBER	DESCRIPTION
4	H100460	LAG SCREW WH 1/4x1 BLK

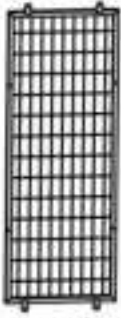

MP01 METAL PANEL - A4M02614
(x1)

- USE PILOT HOLES TO ALIGN HOLES

460 (x4)
LAG SCREW - 1"

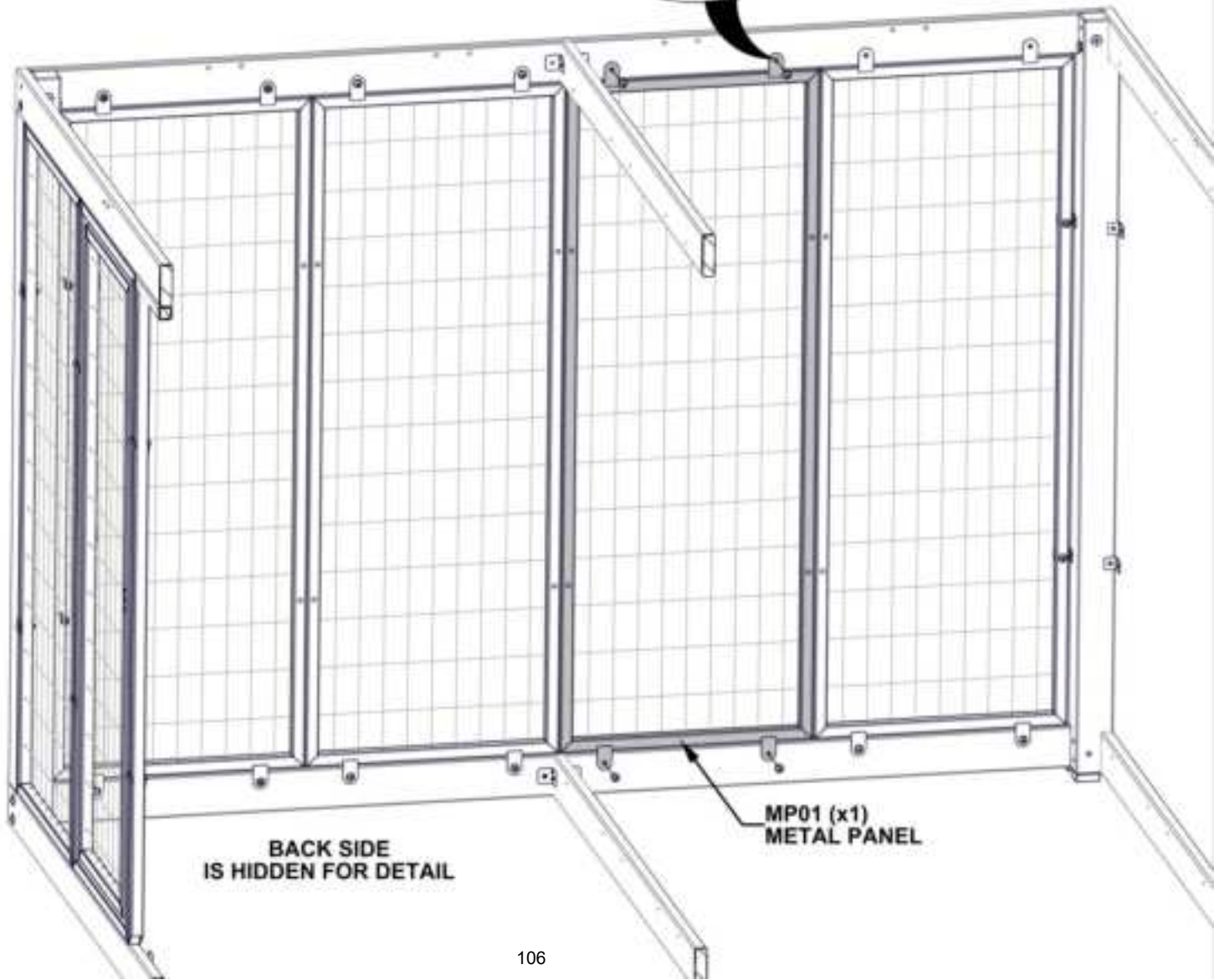
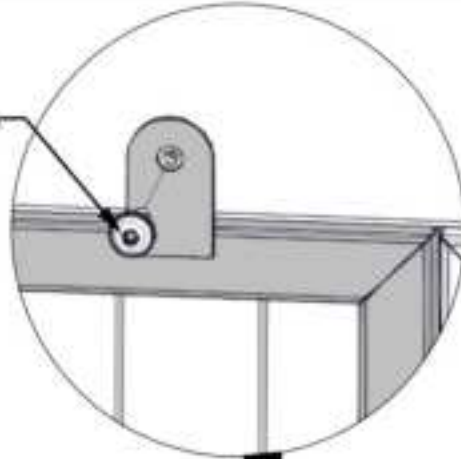

BACK SIDE
IS HIDDEN FOR DETAIL

MP01 (x1)
METAL PANEL

STEP 42E - FRONT SIDE

QTY	PART NUMBER	DESCRIPTION
12	H100486	BOLT WH 1/4x5/8 BLK
12	H100404	NUT BARREL WH 1/4x5/8 BLK



A4M02616 METAL PANEL FLAT BRACKET (x4)

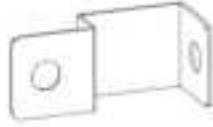

A4M06816 DOOR BRACKET (x4)

- ALIGN BRACKETS WITH HOLES
- SQUARE BRACKETS BEFORE LOCKING HARDWARE

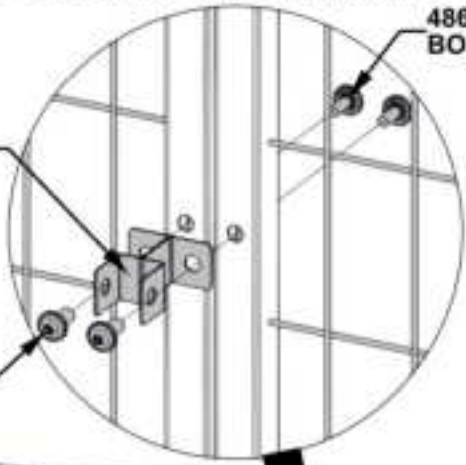

6816 (x4) DOOR BRACKET

486 (x4) BOLT - 5/8"

404 (x4) BARREL NUT - 5/8"

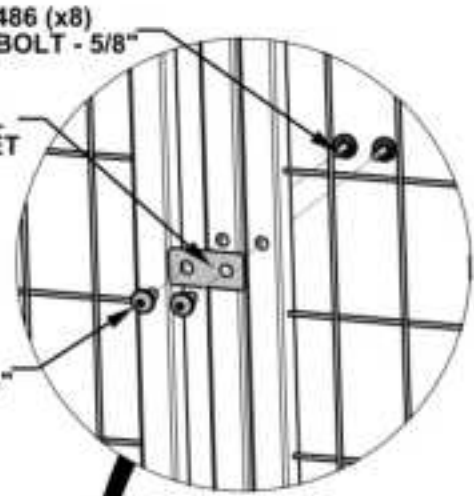

2616 (x4) METAL PANEL FLAT BRACKET

486 (x8) BOLT - 5/8"

404 (x8) BARREL NUT - 5/8"

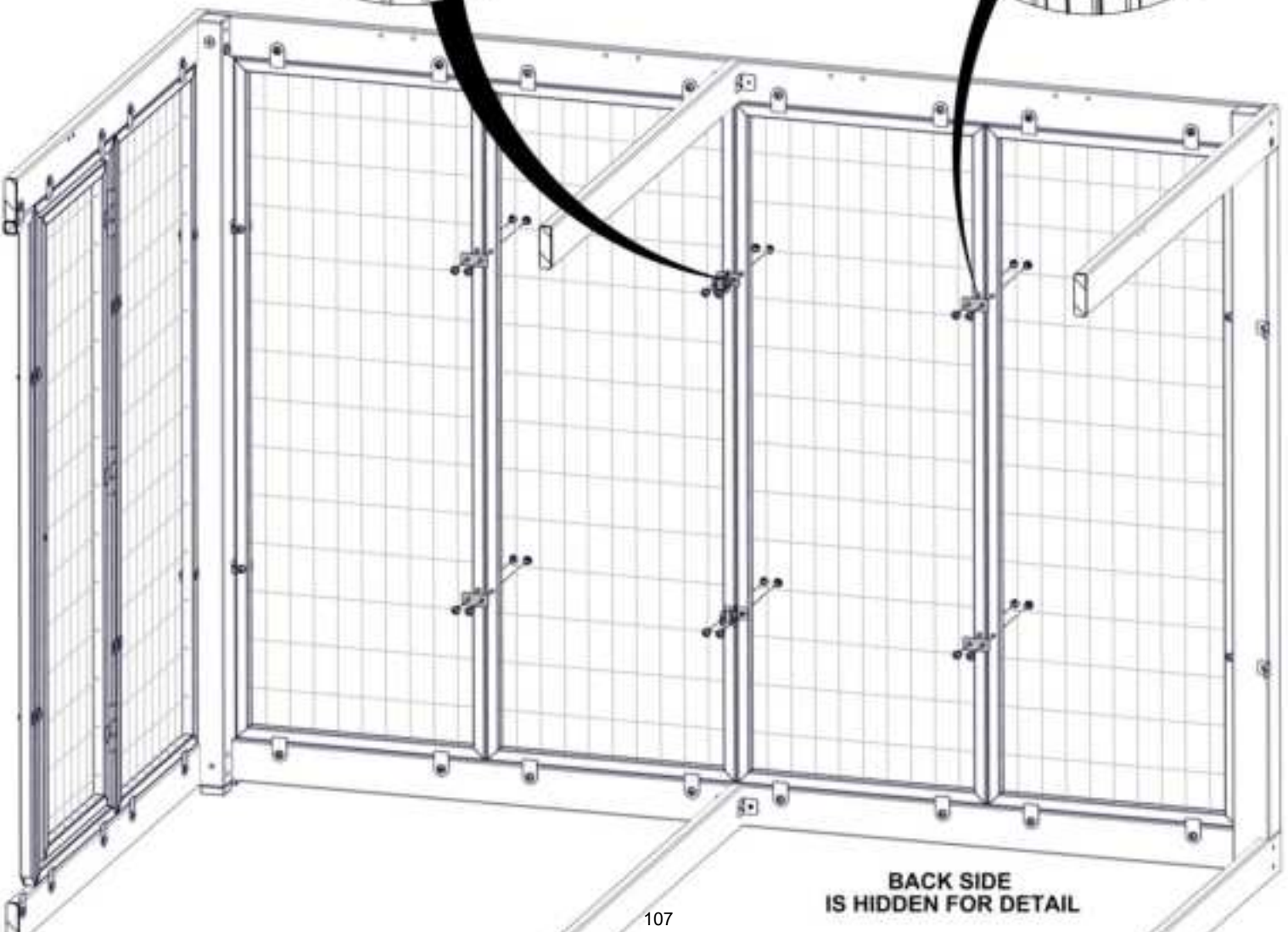

BACK SIDE IS HIDDEN FOR DETAIL

STEP 43A - LEFT SIDE

QTY	PART NUMBER	DESCRIPTION
2	H100486	BOLT WH 1/4x5/8 BLK
4	H100460	LAG SCREW WH 1/4x1 BLK
2	H100404	NUT BARREL WH 1/4X5/8 BLK

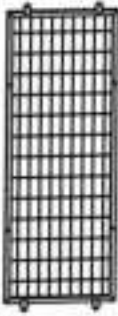

MP01 METAL PANEL - A4M02614
(x1)

- USE PILOT HOLES TO ALIGN HOLES

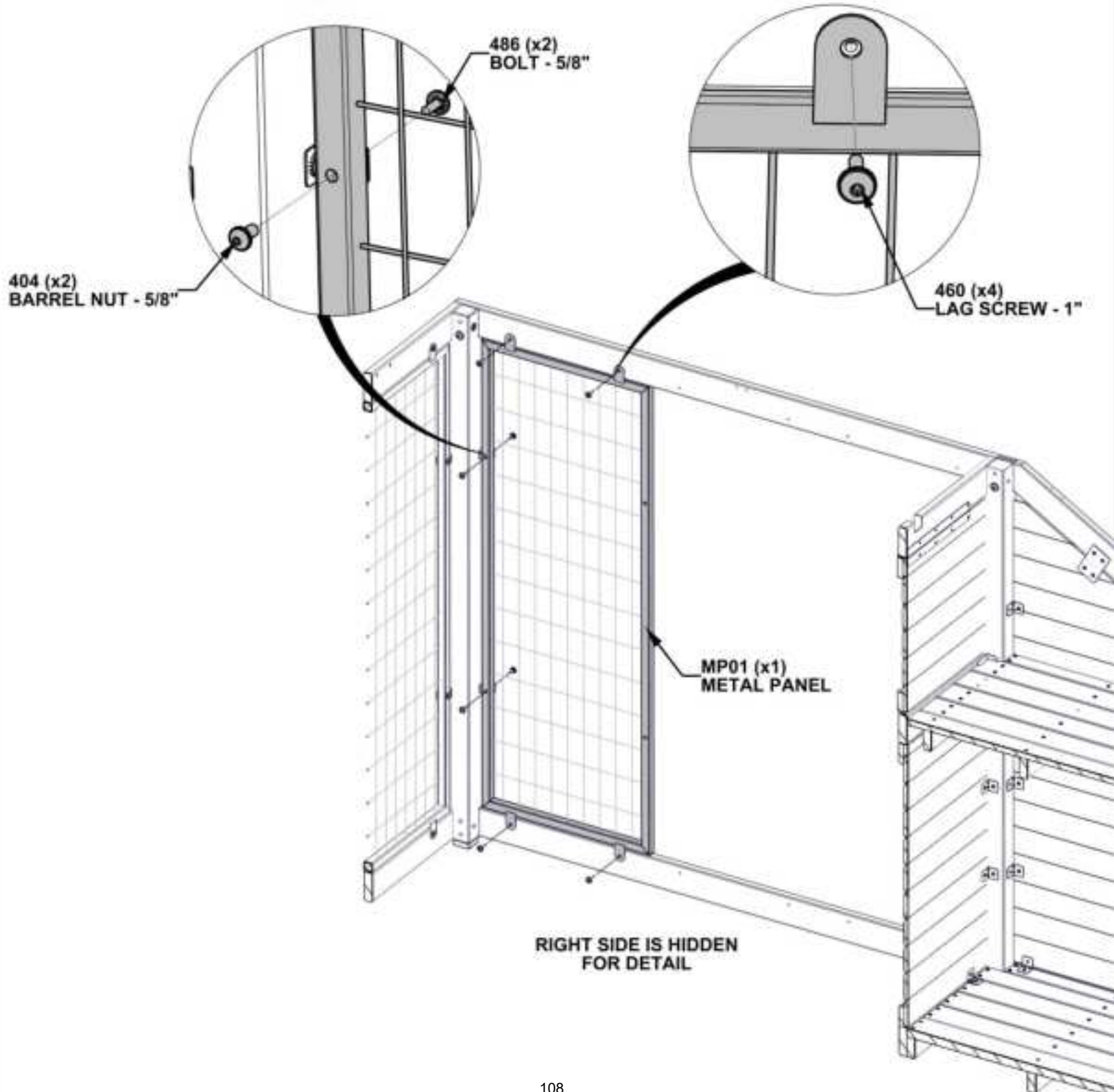

STEP 43B - LEFT SIDE

QTY	PART NUMBER	DESCRIPTION
2	H100486	BOLT WH 1/4x5/8 BLK
4	H100460	LAG SCREW WH 1/4x1 BLK
2	H100404	NUT BARREL WH 1/4X5/8 BLK

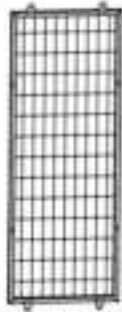

MP01 METAL PANEL - A4M02614 (x1)

- USE PILOT HOLES TO ALIGN HOLES

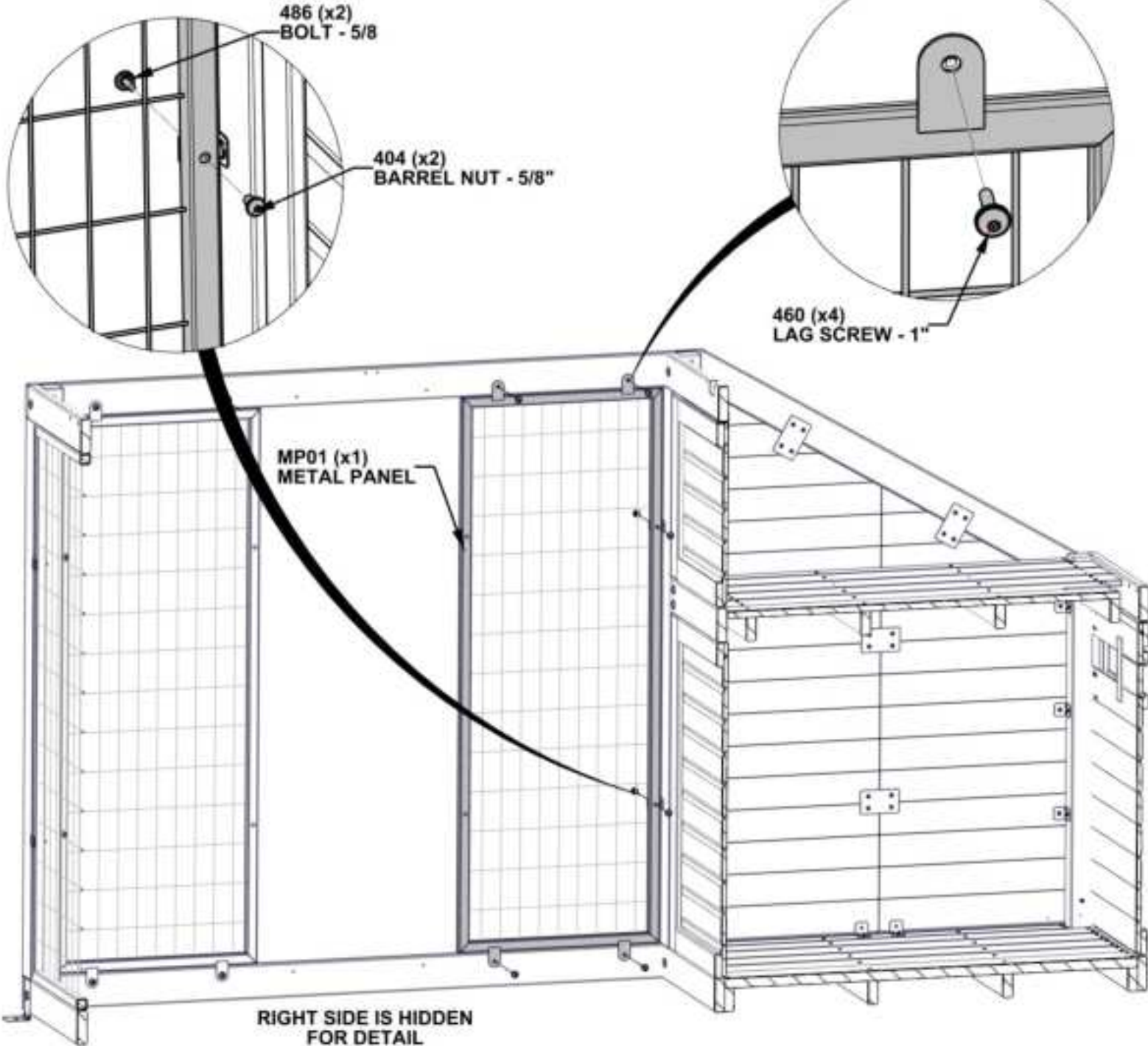

STEP 43C - LEFT SIDE

QTY	PART NUMBER	DESCRIPTION
4	H100460	LAG SCREW WH 1/4x1 BLK

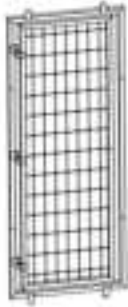

MP04 METAL DOOR PANEL ASSEMBLY - A4M065B1
(x1)

- USE PILOT HOLES TO ALIGN HOLES

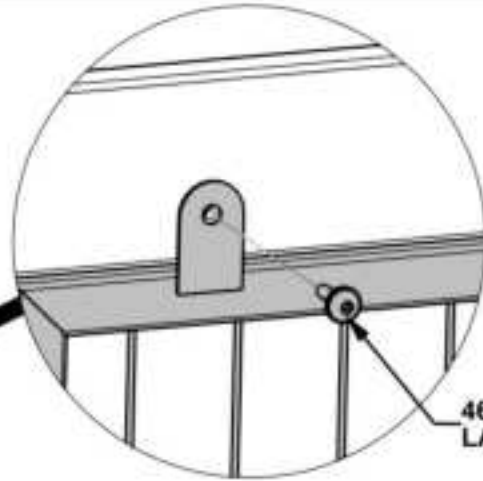

MP04 (x1)
METAL DOOR
PANEL ASSEMBLY

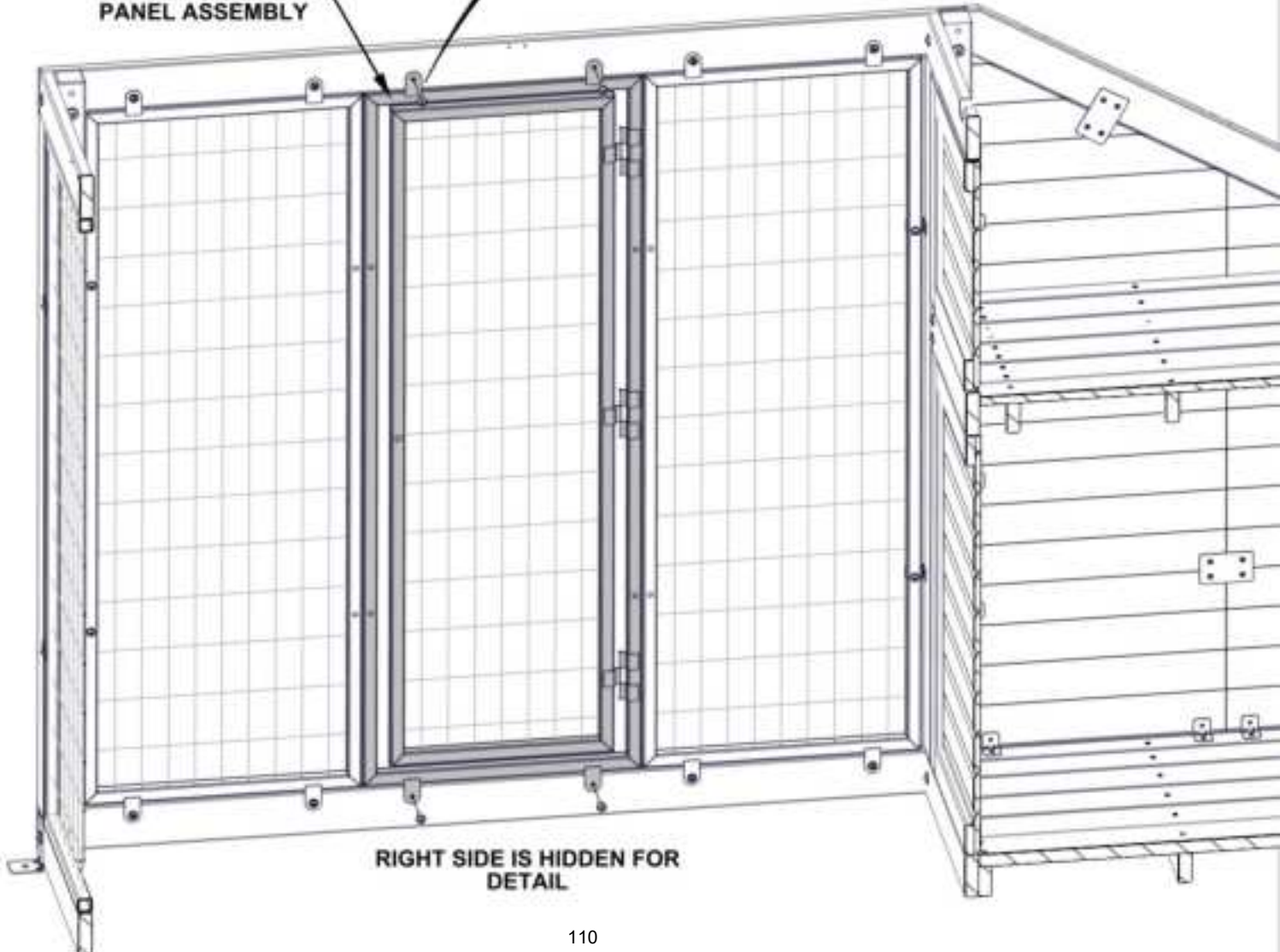

RIGHT SIDE IS HIDDEN FOR
DETAIL

STEP 43D - LEFT SIDE

QTY	PART NUMBER	DESCRIPTION
8	H100486	BOLT WH 1/4x5/8 BLK
8	H100404	NUT BARREL WH 1/4X5/8 BLK



A4M02616 METAL PANEL FLAT BRACKET
(x4)

- ALIGN BRACKETS WITH HOLES
- SQUARE BRACKETS BEFORE LOCKING HARDWARE

486 (x8)
BOLT - 5/8"

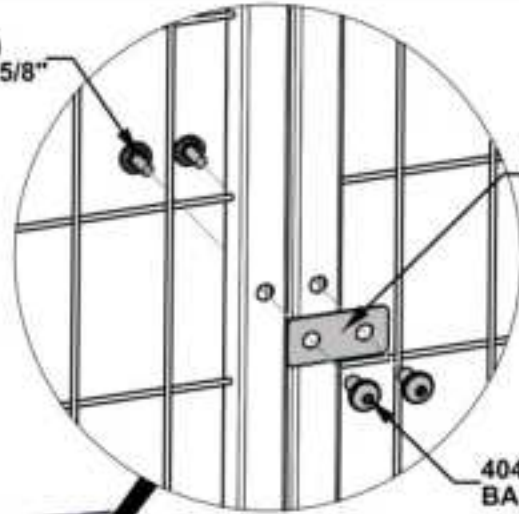

2616 (x4)
METAL PANEL
FLAT BRACKET

404 (x8)
BARREL NUT - 5/8"

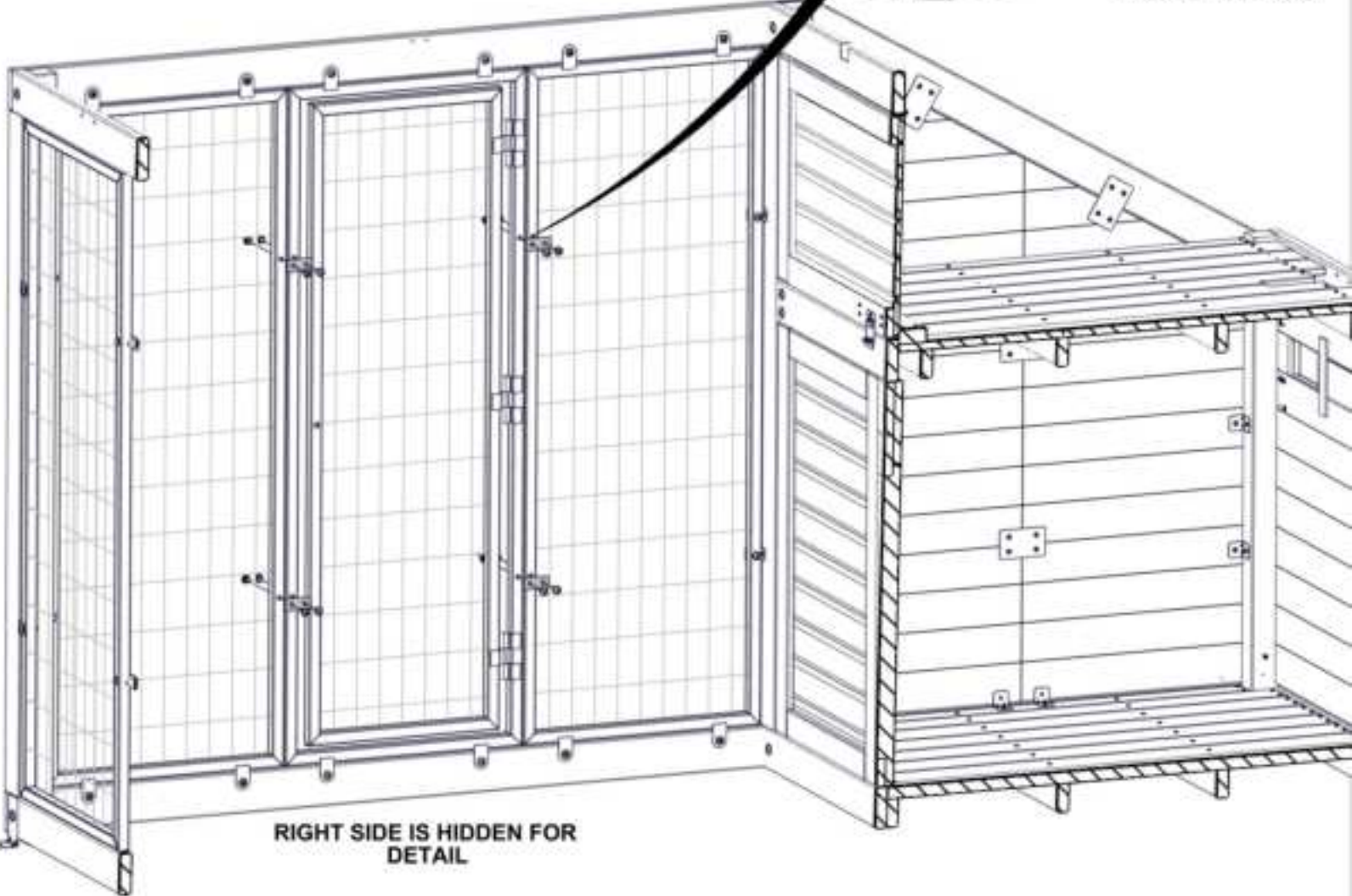

RIGHT SIDE IS HIDDEN FOR
DETAIL

STEP 44A - HANDLE ASSEMBLY

QTY	PART NUMBER	DESCRIPTION
2	H101401	SCREW POH 8/32x1/2 BLK



A4M06584 METAL PANEL TAB
(x1)

- ALIGN BRACKET WITH THREADS
- SQUARE BRACKETS BEFORE LOCKING HARDWARE

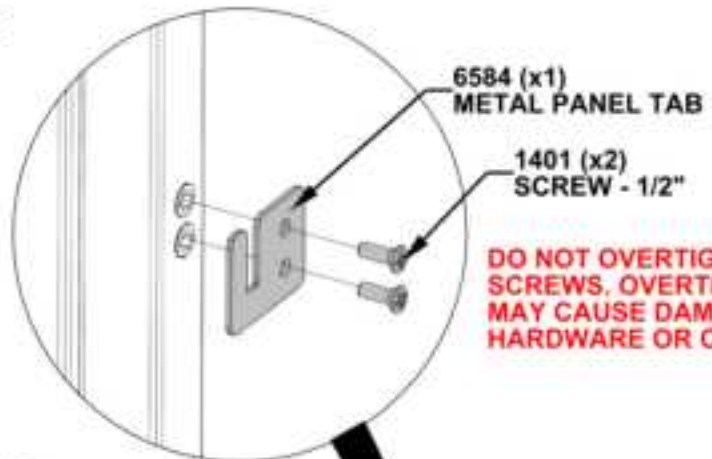

**DO NOT OVERTIGHTEN
SCREWS. OVERTIGHTENING
MAY CAUSE DAMAGE TO
HARDWARE OR COMPONENT.**

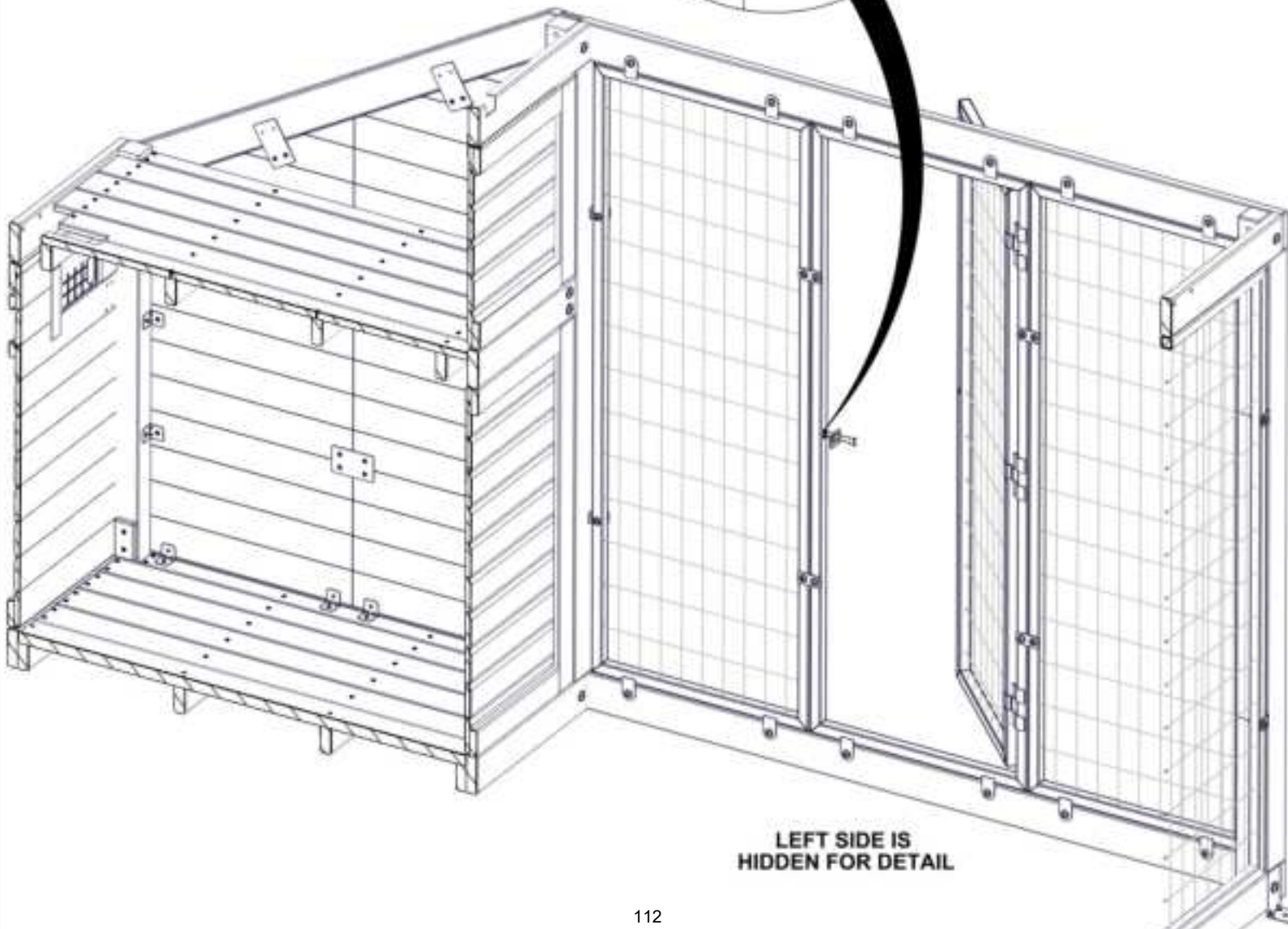

**LEFT SIDE IS
HIDDEN FOR DETAIL**

STEP 44B - HANDLE ASSEMBLY

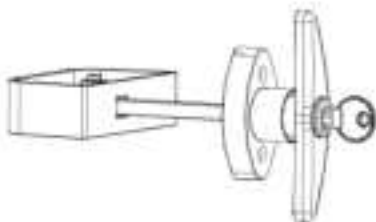

A4M00839 HANDLE W/ LOCK
(x1)

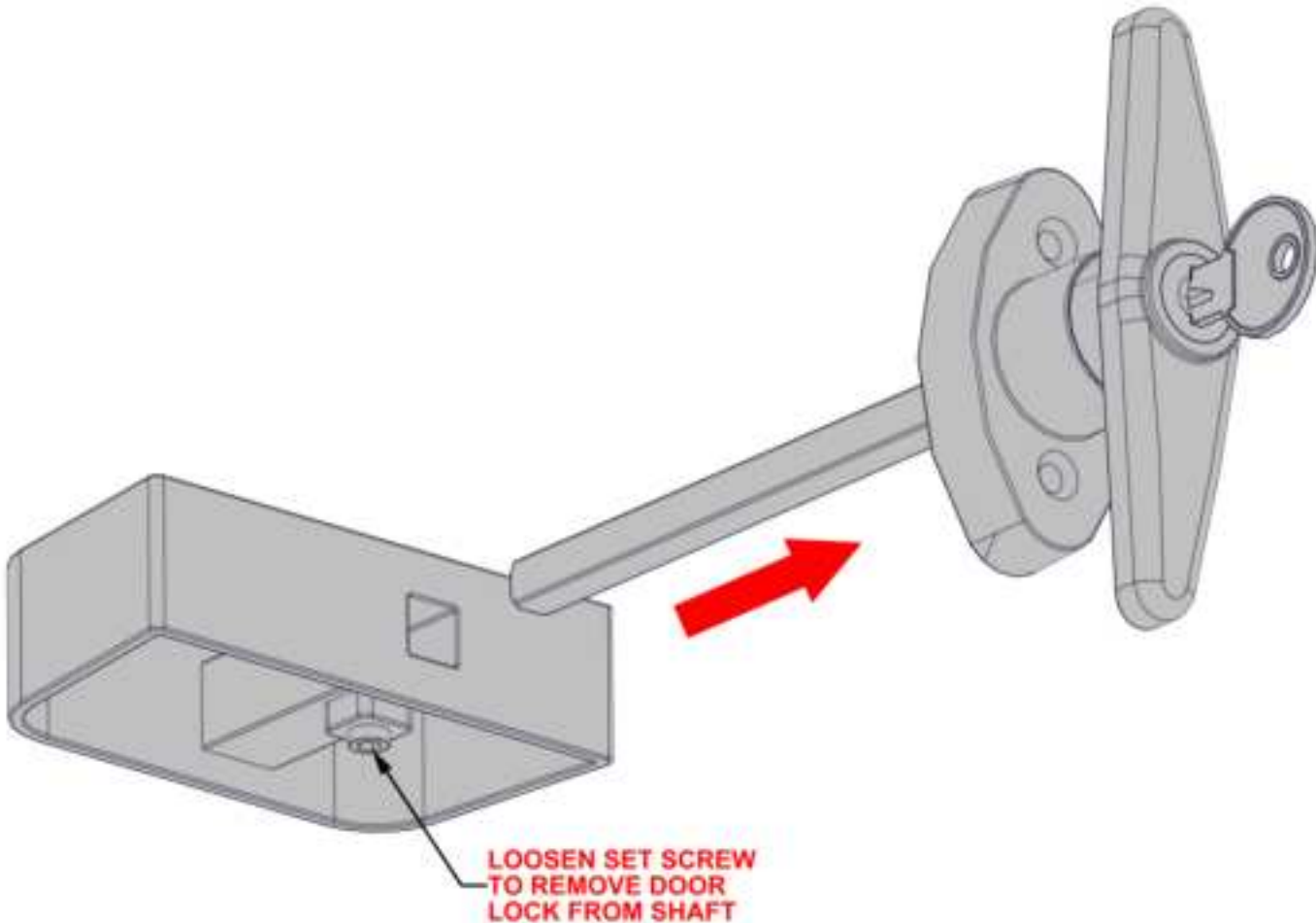

STEP 45 - HANDLE ASSEMBLY

QTY	PART NUMBER	DESCRIPTION
2	H100807	SCREW POH 8/32x1 BLK

- ALIGN HANDLE WITH THREADS

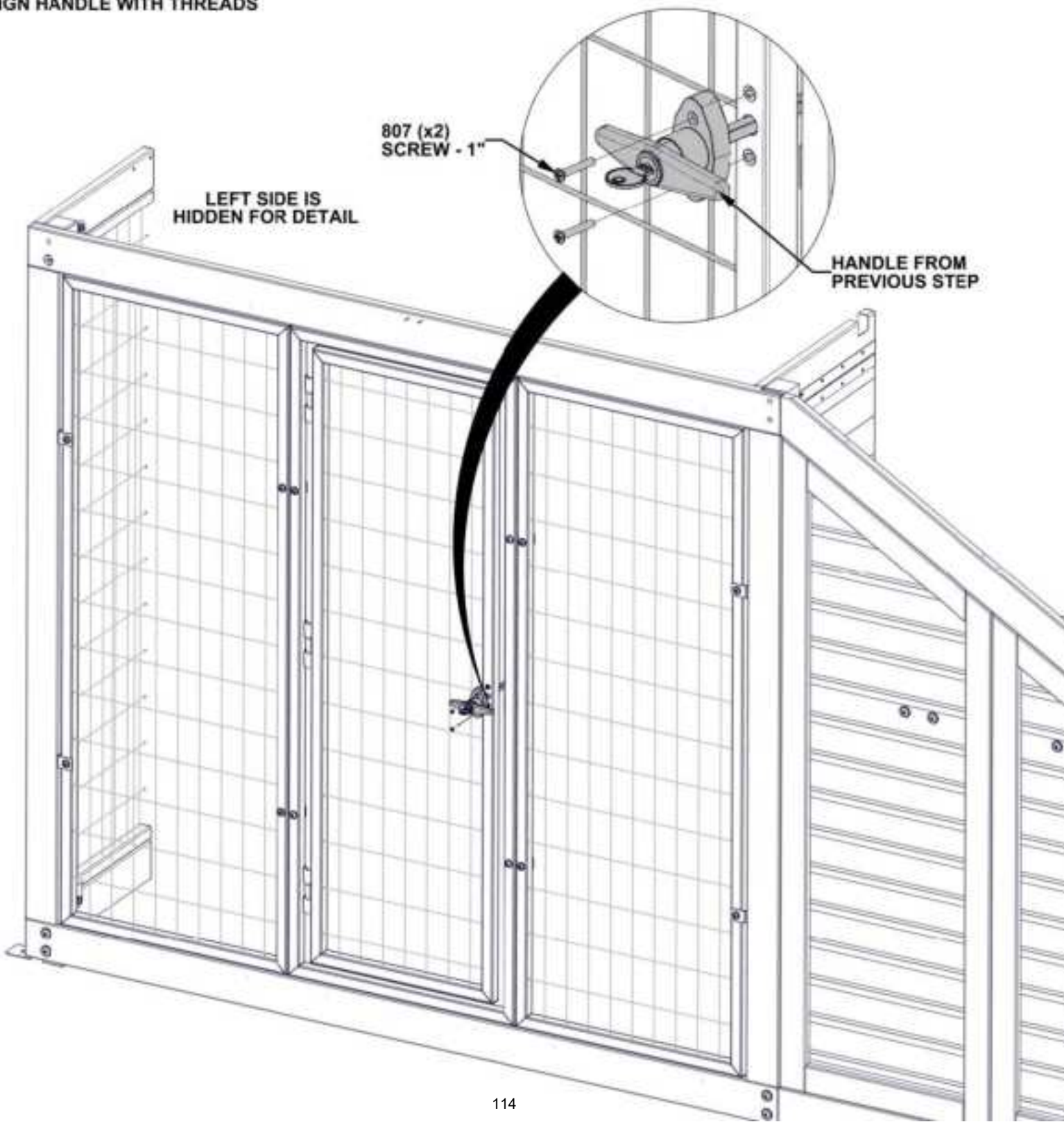

STEP 46 - HANDLE ASSEMBLY

- REPEAT STEPS 44A-44D ON SECOND DOOR.

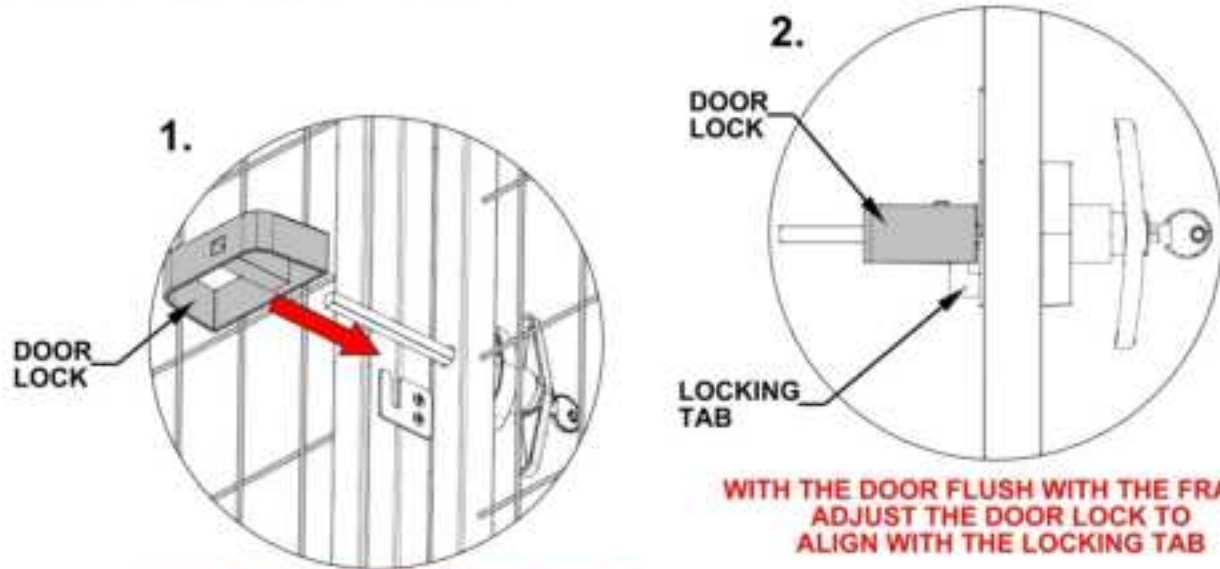

**SLIDE DOOR LOCK BACK ON SHAFT
WITH SET SCREW FACING UP.**

**WITH THE DOOR FLUSH WITH THE FRAME,
ADJUST THE DOOR LOCK TO
ALIGN WITH THE LOCKING TAB**

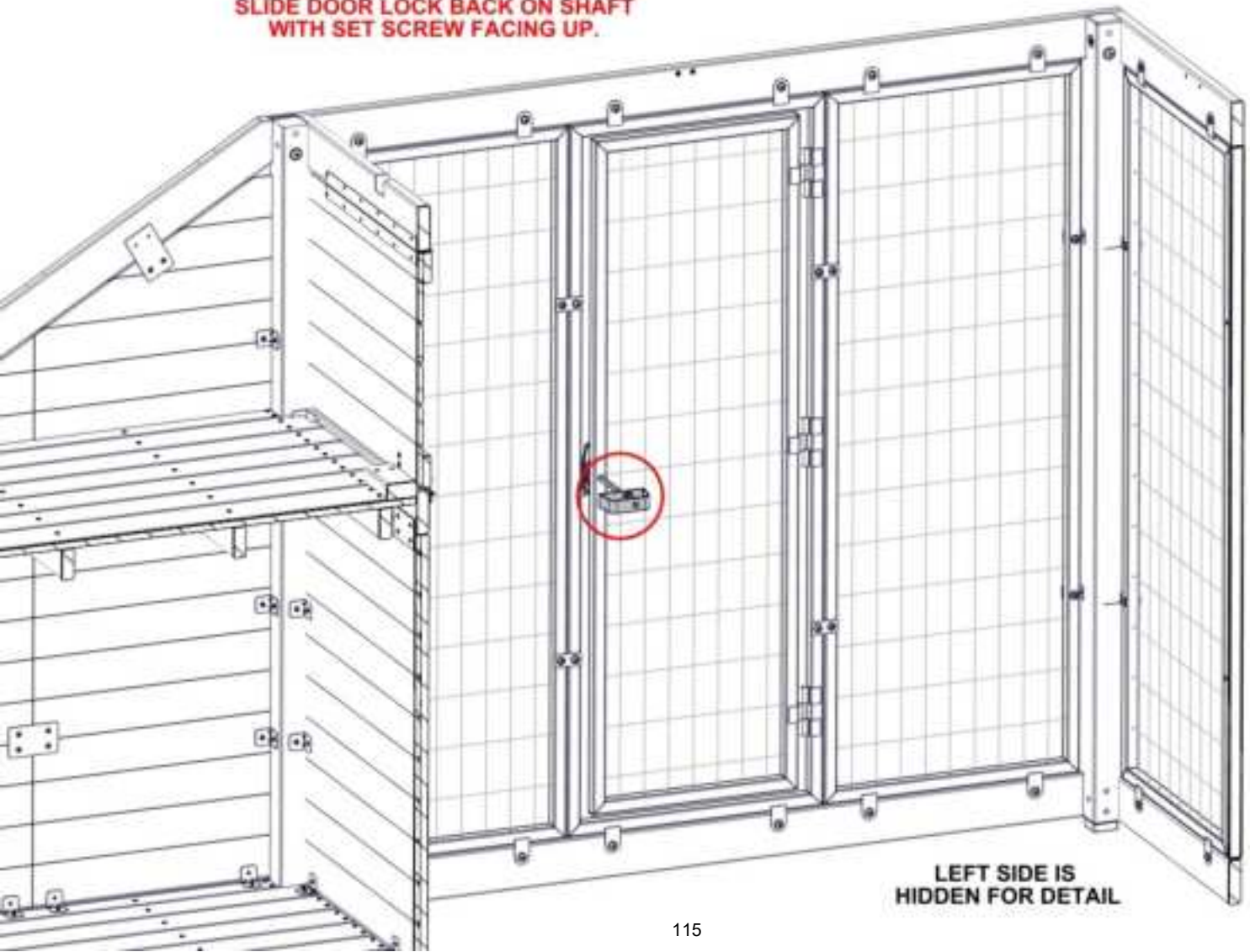

STEP 47A - MIDDLE CAGE

QTY	PART NUMBER	DESCRIPTION
2	H101111	BOLT WH 1/4x3/4 BLK
4	H100460	LAG SCREW WH 1/4x1 BLK
2	H100404	NUT BARREL WH 1/4X 5/8 BLK



MP01 METAL PANEL - A4M02614 (x1)

- USE PILOT HOLES TO ALIGN CAGE HOLES

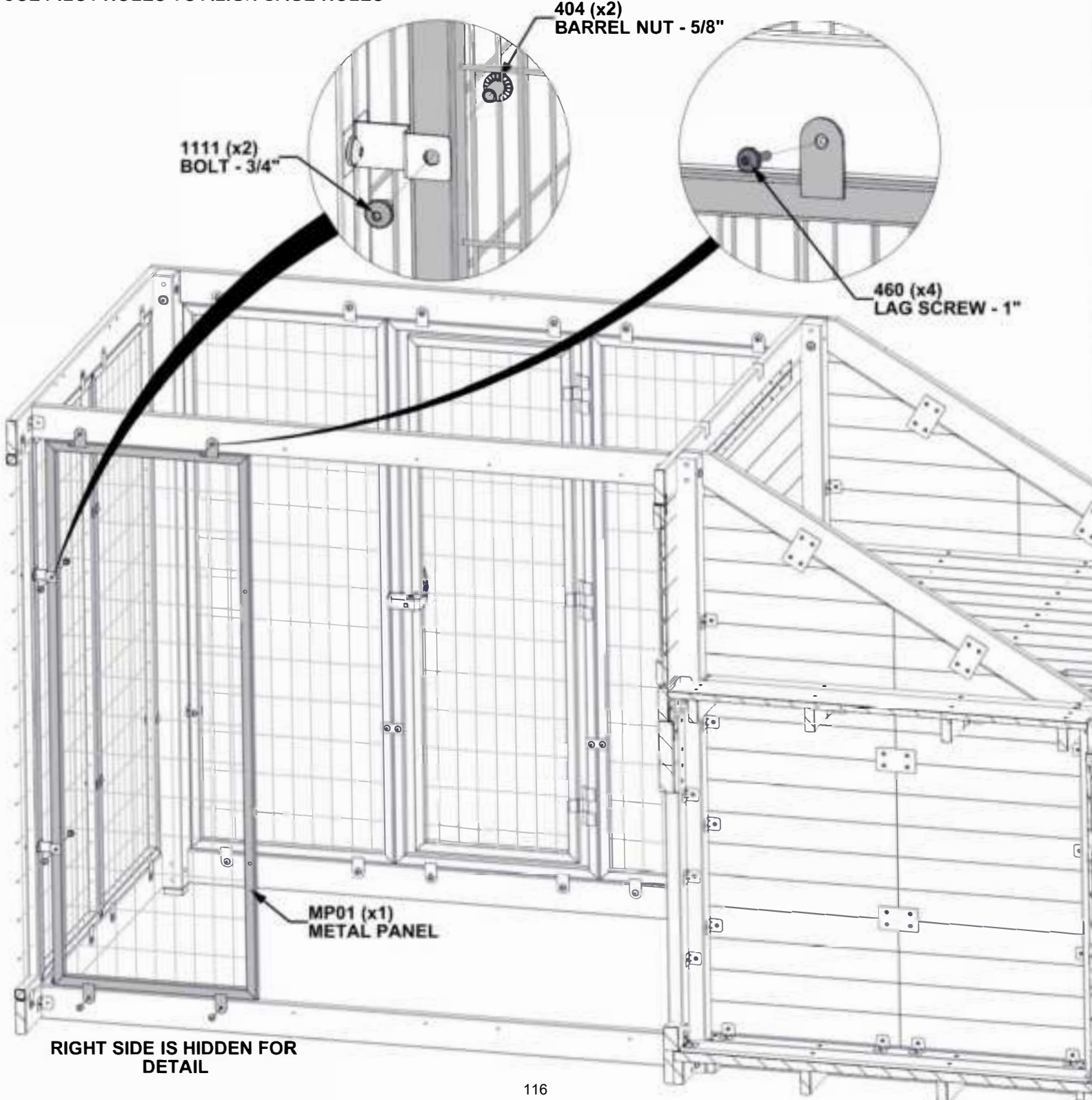

1111 (x2)
BOLT - 3/4"

404 (x2)
BARREL NUT - 5/8"

460 (x4)
LAG SCREW - 1"

MP01 (x1)
METAL PANEL

RIGHT SIDE IS HIDDEN FOR
DETAIL

STEP 47B - MIDDLE CAGE



MP01 METAL PANEL - A4M02614
(x1)

QTY	PART NUMBER	DESCRIPTION
4	H100460	LAG SCREW WH 1/4x1 BLK

- USE PILOT HOLES TO ALIGN CAGE HOLES

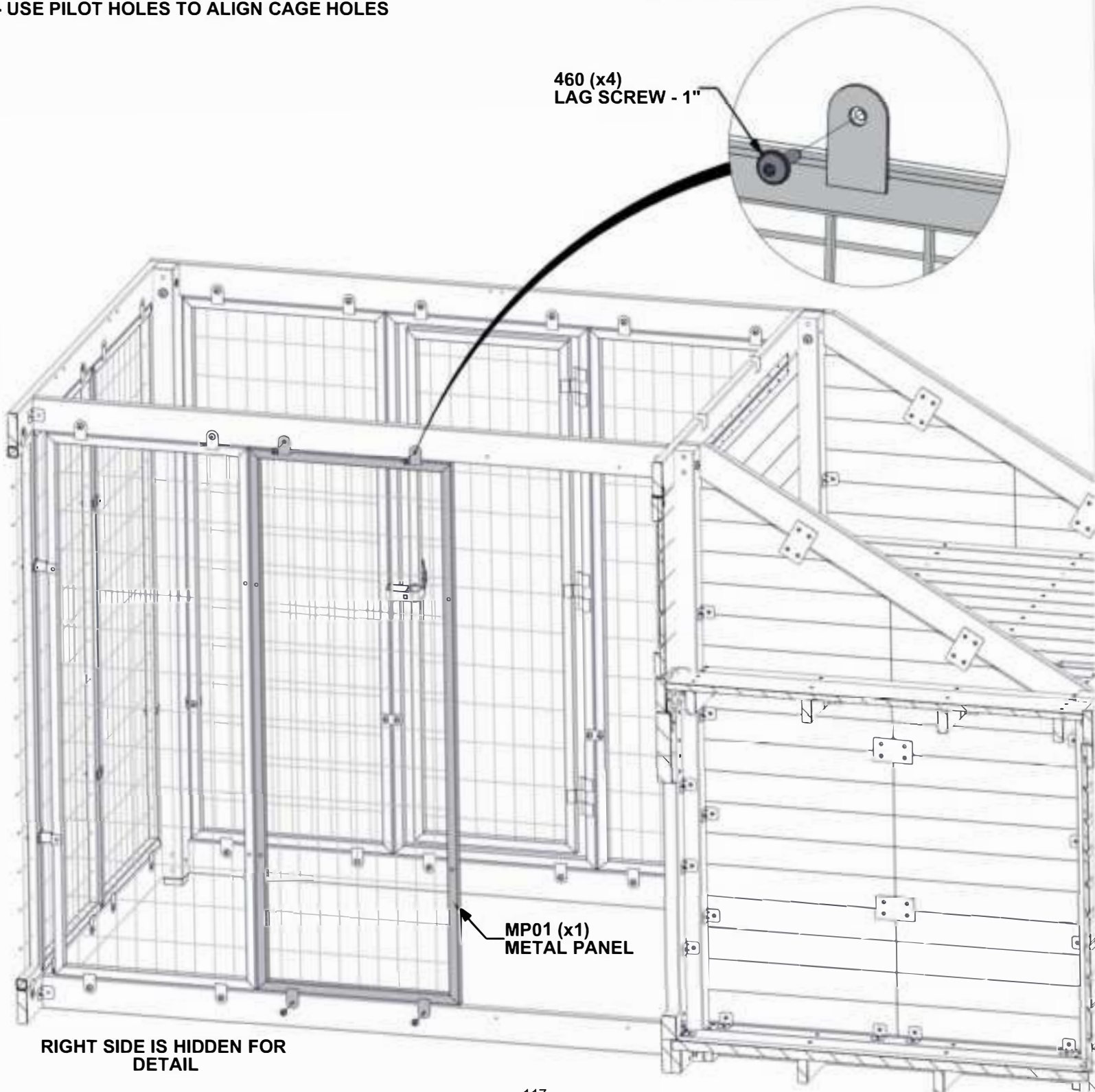

RIGHT SIDE IS HIDDEN FOR
DETAIL

STEP 47C - MIDDLE CAGE

QTY	PART NUMBER	DESCRIPTION
2	H100460	LAG SCREW WH 1/4x1 BLK



A4M06815 METAL PANEL BRACKET
(x2)

- ALIGN BRACKETS WITH PILOT HOLES
- SQUARE BRACKETS BEFORE LOCKING HARDWARE

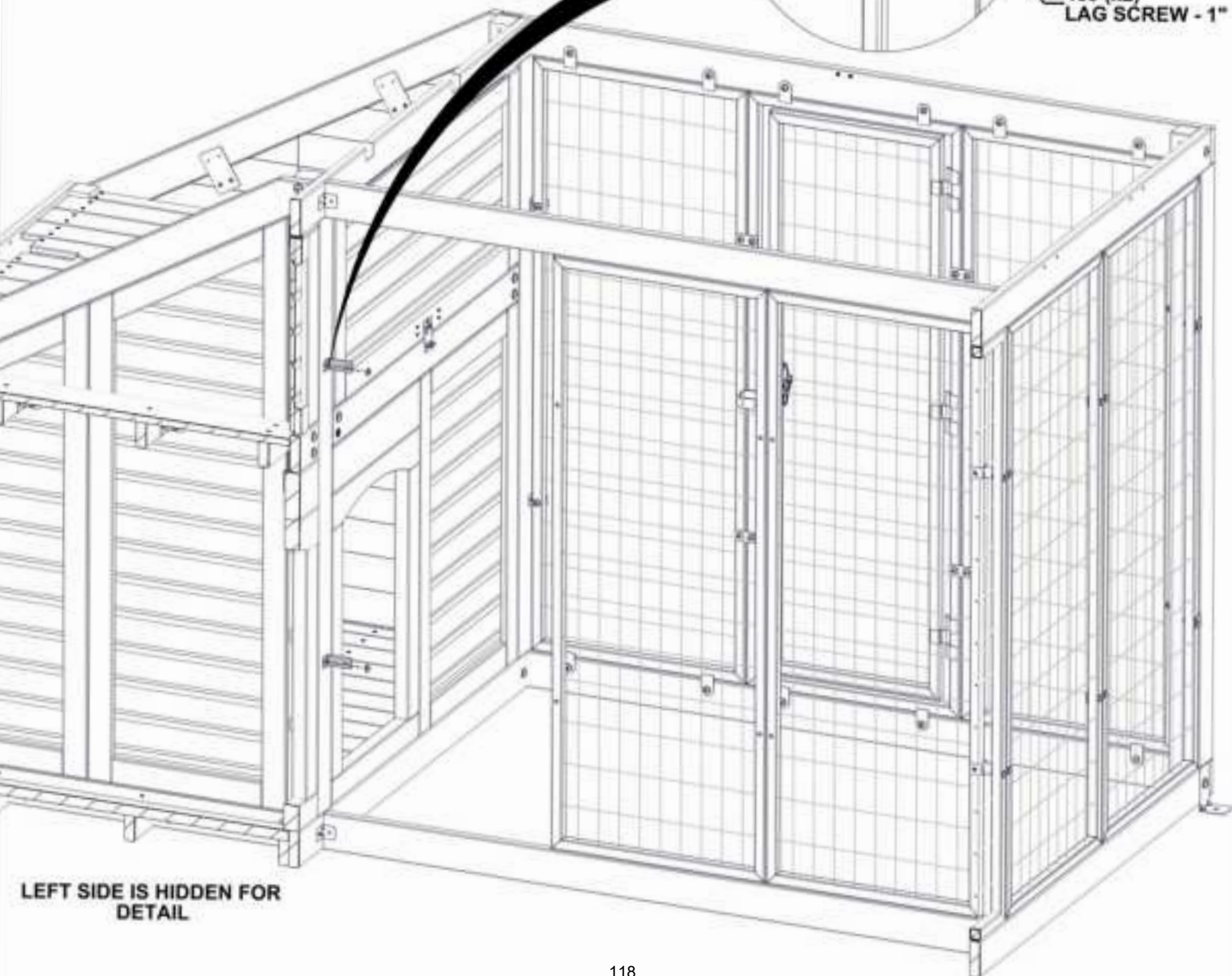
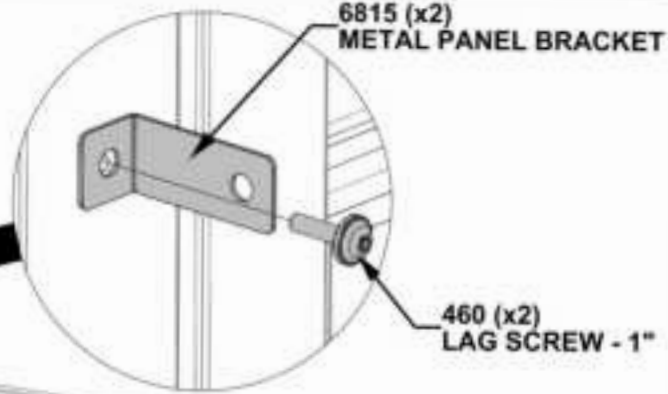

LEFT SIDE IS HIDDEN FOR
DETAIL

STEP 47D - MIDDLE CAGE

QTY	PART NUMBER	DESCRIPTION
2	H101111	BOLT WH 1/4x3/4 BLK
4	H100460	LAG SCREW WH 1/4x1 BLK
2	H100404	NUT BARREL WH 1/4X 5/8 BLK

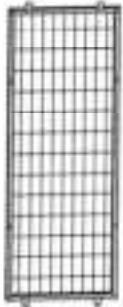

MP01 METAL PANEL - A4M02614
(x1)

- USE PILOT HOLES TO ALIGN CAGE HOLES

404 (x2)
BARREL NUT - 5/8"

460 (x4)
LAG SCREW - 1"

1111 (x2)
BOLT - 3/4"

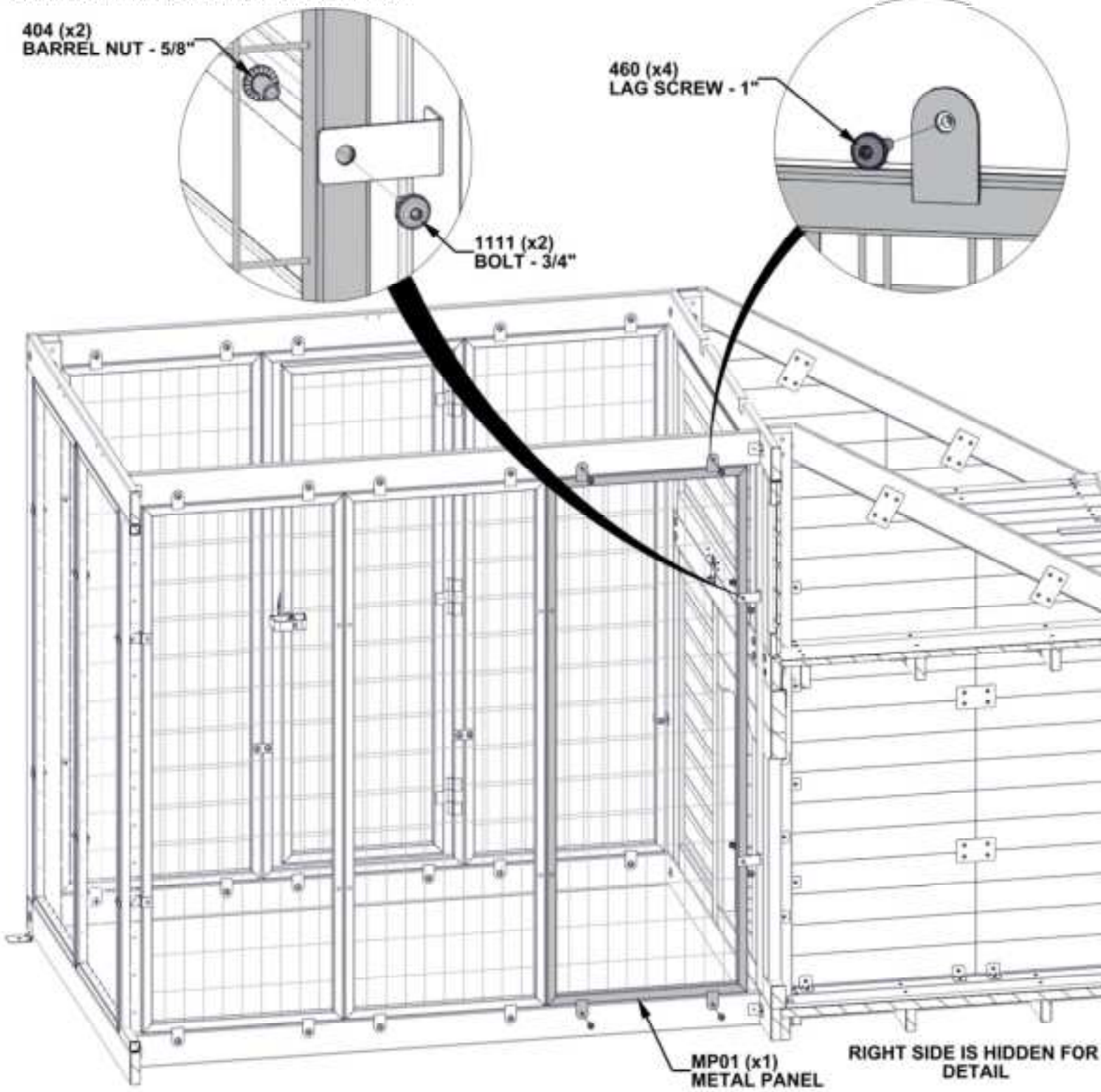

MP01 (x1)
METAL PANEL

RIGHT SIDE IS HIDDEN FOR
DETAIL

STEP 47E - MIDDLE CAGE

QTY	PART NUMBER	DESCRIPTION
8	H100486	BOLT WH 1/4x5/8 BLK
8	H100404	NUT BARREL WH 1/4X5/8 BLK



A4M02616 METAL PANEL FLAT BRACKET
(x4)

- ALIGN BRACKETS WITH HOLES
- SQUARE BRACKETS BEFORE LOCKING HARDWARE

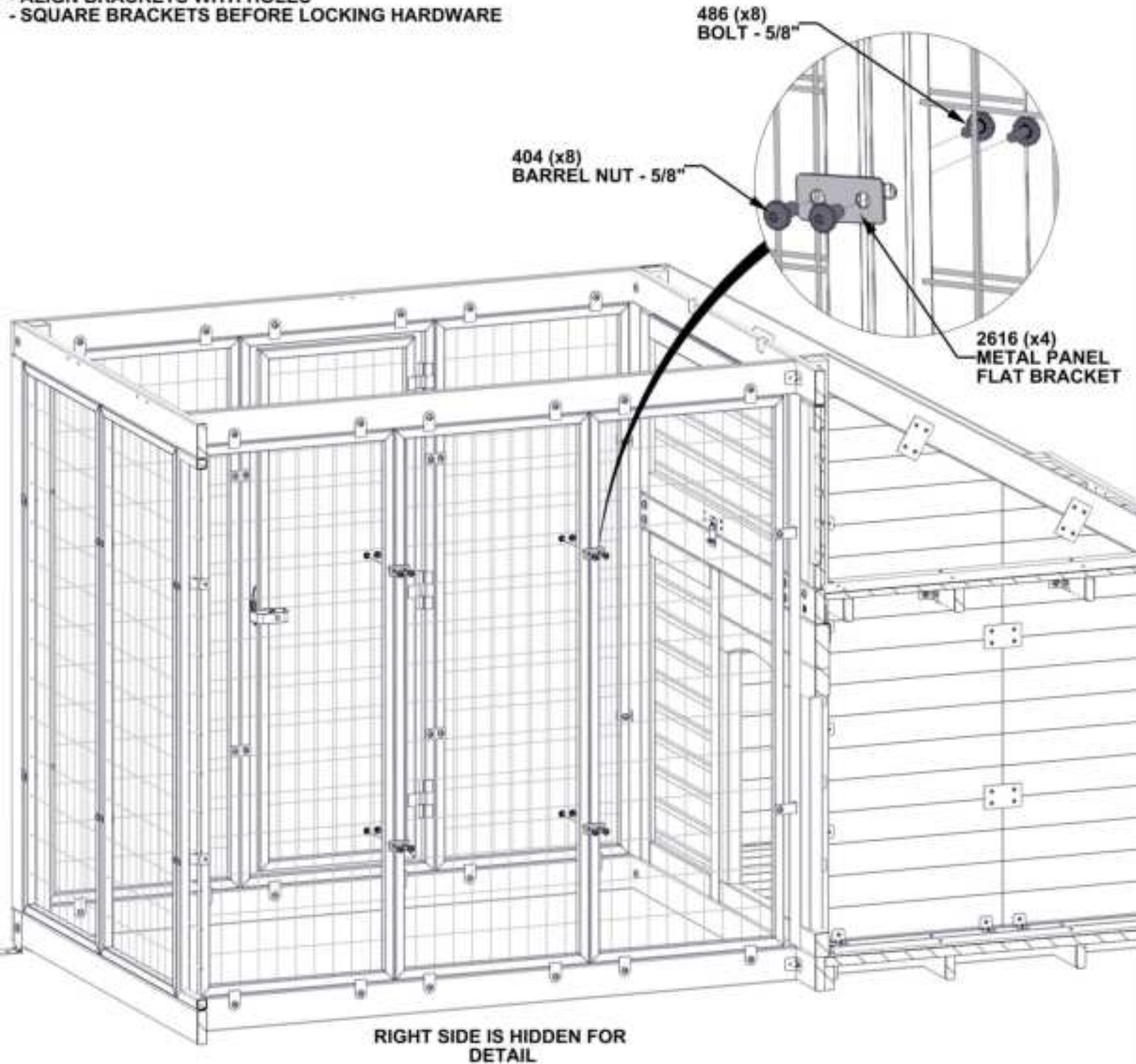

STEP 48A - ANIMAL ENCLOSURE ASSY

QTY	PART NUMBER	DESCRIPTION
3	H100415	BOLT WH 5/16x3 3/4 BLK
3	H100198	WASHER LOCK EXT 8x19

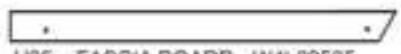

H25 FASCIA BOARD - W4L22525
(x1) 15/16"x3 3/8"x43 5/16" (24x86x1100)

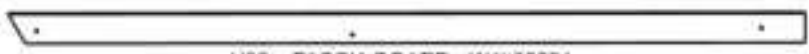

H26 FASCIA BOARD - W4L22524
(x1) 15/16"x3 3/8"x89 1/2" (24x86x2274)

- PILOT HOLES GO TO THE INSIDE

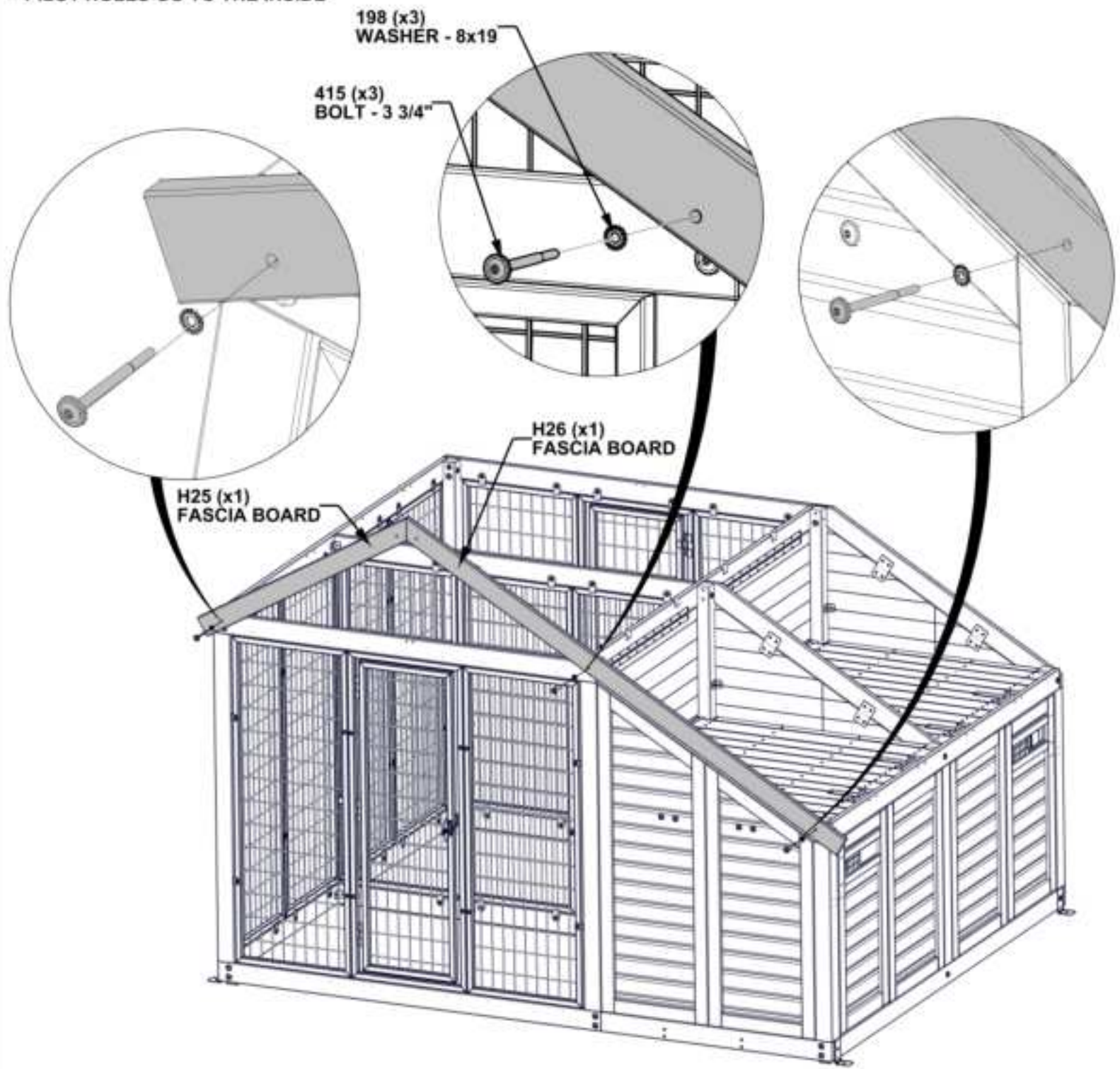

STEP 48B - ANIMAL ENCLOSURE ASSY

QTY	PART NUMBER	DESCRIPTION
3	H100392	SCREW PWH 8x3/4 BLK
18	H100200	SCREW PFH 8x1 1/2 BLK



J8 GABLE BOARD - W4L22528
(x1) 15/16"X3 3/8"X19 5/16" (24x86x490)



J9 GABLE BOARD - W4L22534
(x2) 15/16"X3 3/8"X25 13/16" (24x86x655)



J14 GABLE BOARD - W4L22558
(x2) 15/16"X3 3/8"X15 1/4" (24x86x388)

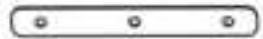

METAL STRAP 118mm - A4M02632
(x1)

- USE PILOT HOLES TO ALIGN SCREWS

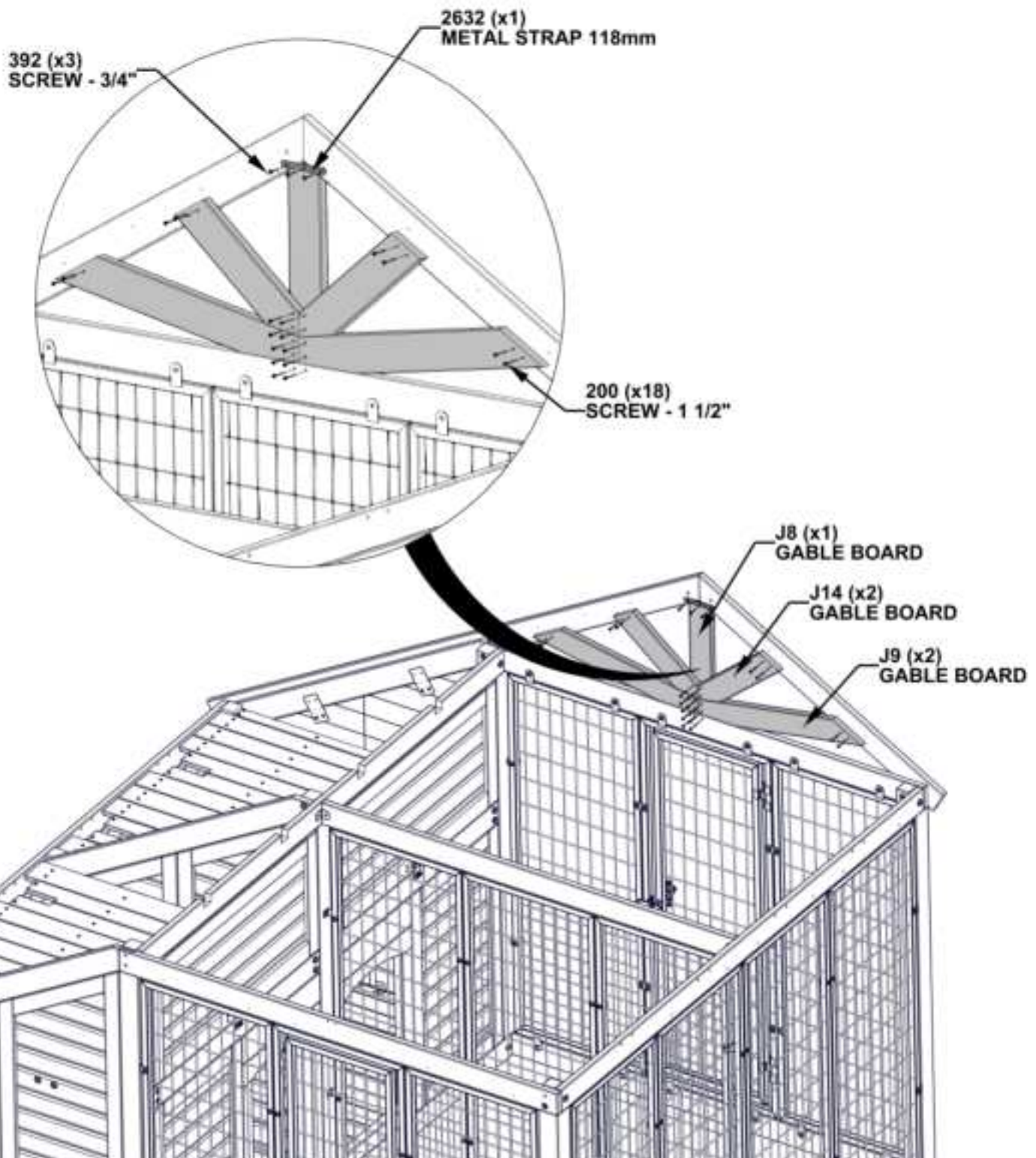

STEP 48C - ANIMAL ENCLOSURE ASSY

QTY	PART NUMBER	DESCRIPTION
6	H100200	SCREW PFH 8x1 1/2 BLK



S1 CLEAT - W4L22533
(x2) 15/16"x15/16"x17 11/16" (24x24x450)

- USE PILOT HOLES TO ALIGN SCREWS

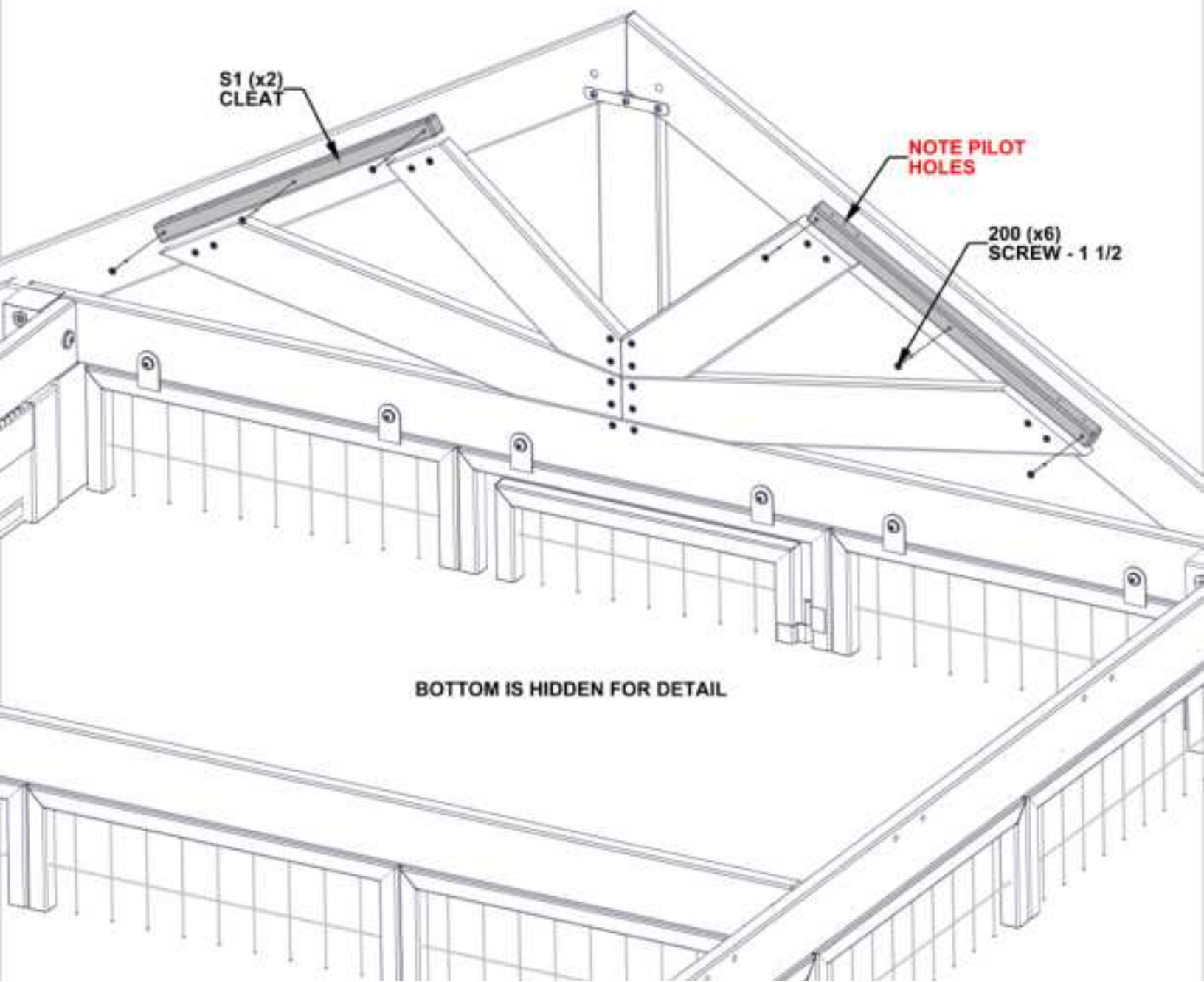

BOTTOM IS HIDDEN FOR DETAIL

STEP 49A - ANIMAL ENCLOSURE ASSY

QTY	PART NUMBER	DESCRIPTION
3	H100415	BOLT WH 5/16x3 3/4 BLK
3	H100198	WASHER LOCK EXT 8x19



H20 FASCIA BOARD - W4L22529
(x1) 15/16"x3 3/8"x43 5/16" (24x86x1100)



H21 FASCIA BOARD - W4L22527
(x1) 15/16"x3 3/8"x89 1/2" (24x86x2274)

- PILOT HOLES GO TO THE INSIDE

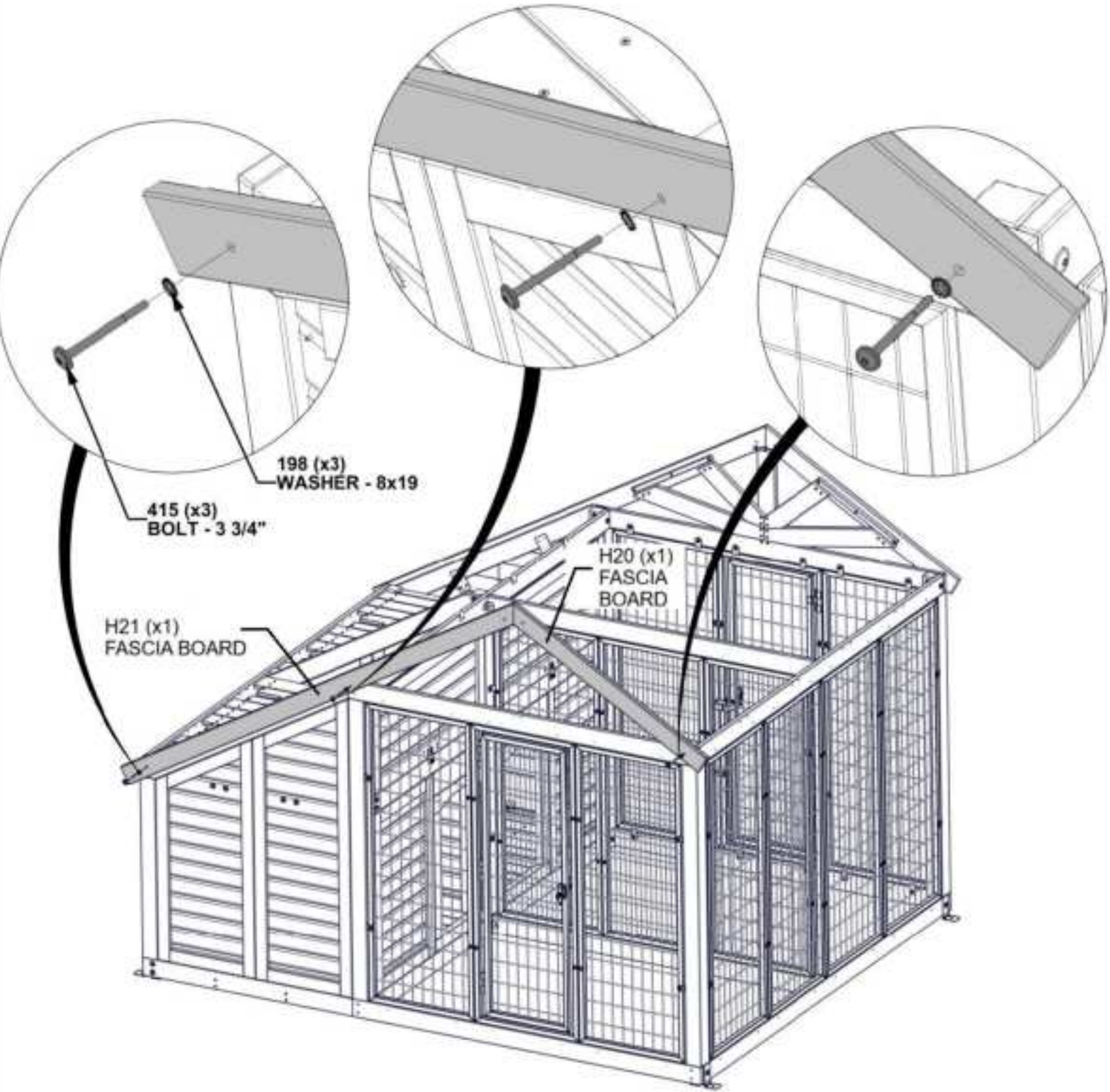

STEP 49B - ANIMAL ENCLOSURE ASSY

QTY	PART NUMBER	DESCRIPTION
3	H100392	SCREW PWH 8x3/4 BLK
18	H100200	SCREW PFH 8x1 1/2 BLK



J8 GABLE BOARD - W4L22528
(x1) 15/16"X3 3/8"X19 5/16" (24x86x490)



J9 GABLE BOARD - W4L22534
(x2) 15/16"X3 3/8"X25 13/16" (24x86x655)



J14 GABLE BOARD - W4L22558
(x2) 15/16"X3 3/8"X15 1/4" (24x86x388)

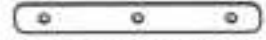

METAL STRAP 118mm - A4M02632
(x1)

- USE PILOT HOLES TO ALIGN SCREWS

392 (x3)
SCREW - 3/4"

2632 (x1)
METAL STRAP 118mm

200 (x18)
SCREW - 1 1/2"

J8 (x1)
GABLE BOARD

J14 (x2)
GABLE BOARD

J9 (x2)
GABLE BOARD

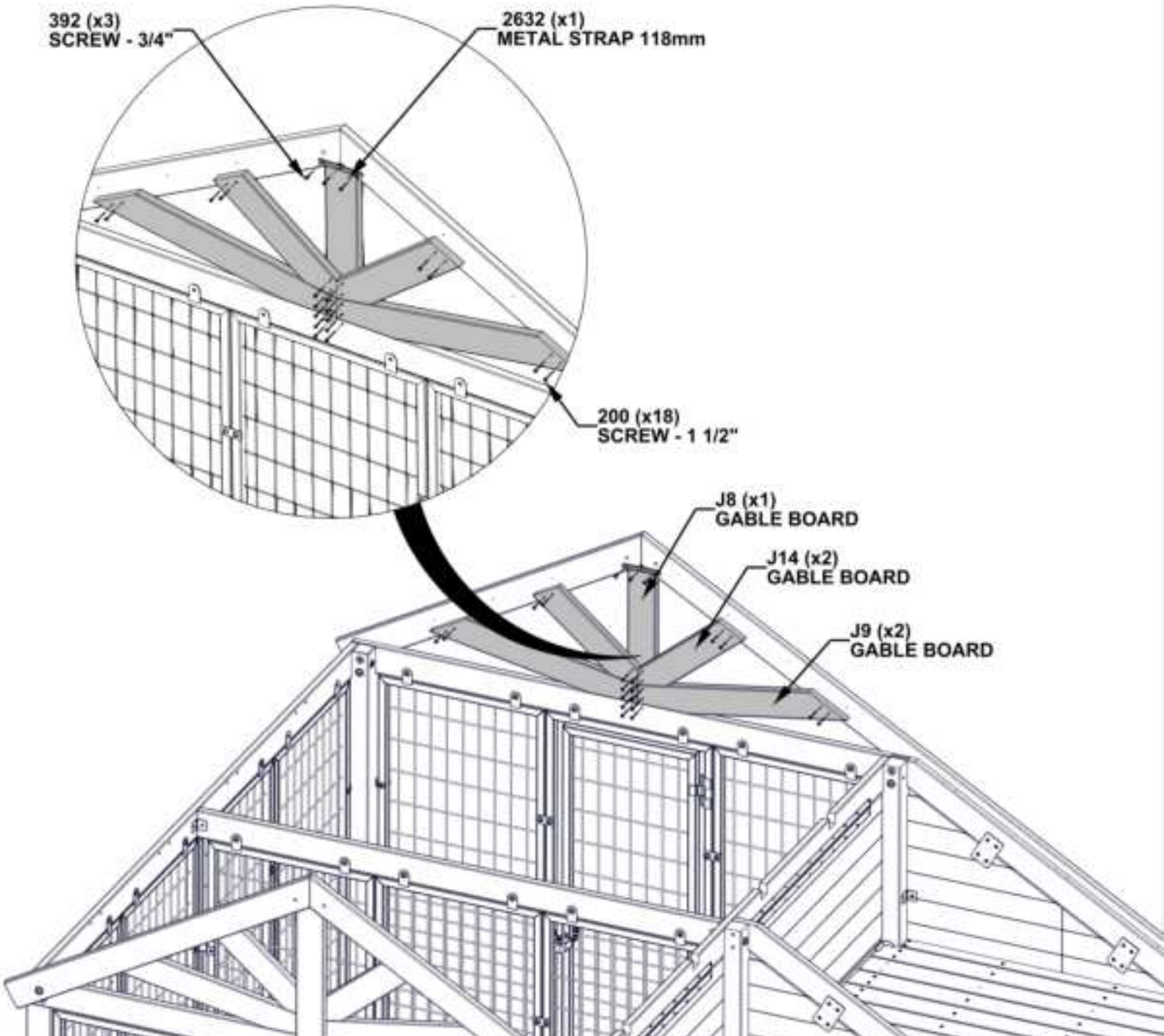

STEP 49C -ANIMAL ENCLOSURE ASSY

QTY	PART NUMBER	DESCRIPTION
6	H100200	SCREW PFH 8x1 1/2 BLK



S1 CLEAT - W4L22533
(x2) 15/16"x15/16"x17 11/16" (24x24x450)

- USE PILOT HOLES TO ALIGN SCREWS

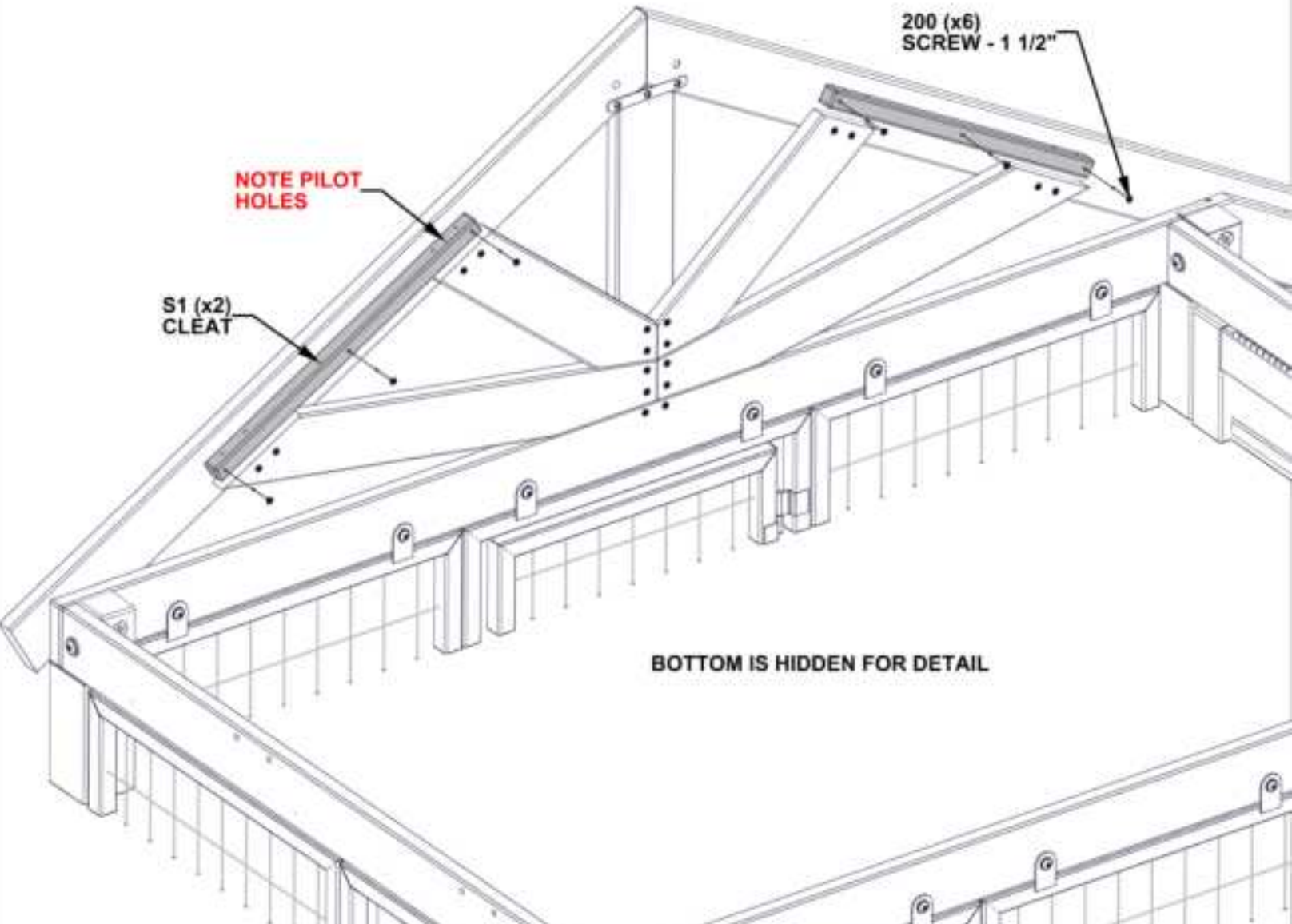

STEP 50 - ANIMAL ENCLOSURE ASSY

QTY	PART NUMBER	DESCRIPTION
8	H100486	BOLT WH 1/4x5/8 BLK
8	H100405	WASHER LOCK EXT 6x15
8	H100404	NUT BARREL WH 1/4X5/8 BLK

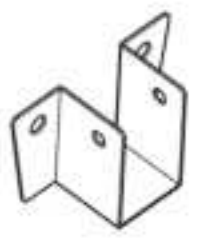

A4M01787 RAFTER BRACKET
(x4)

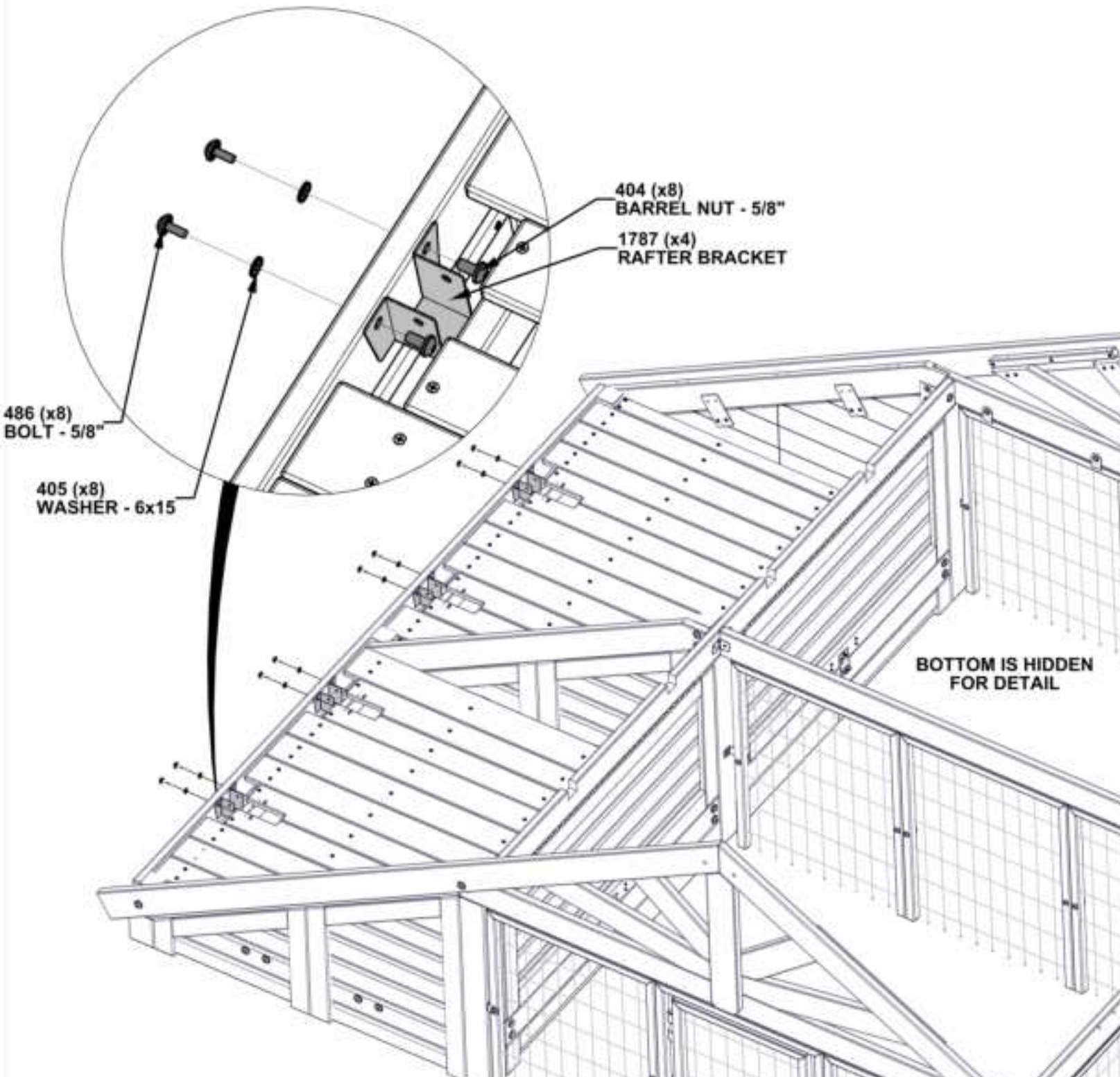

STEP 51 -ANIMAL ENCLOSURE ASSY

QTY	PART NUMBER	DESCRIPTION
8	H100486	BOLT WH 1/4x5/8 BLK
8	H100405	WASHER LOCK EXT 6x15
8	H100404	NUT BARREL WH 1/4X5/8 BLK



A4M01787 RAFTER BRACKET
(x4)

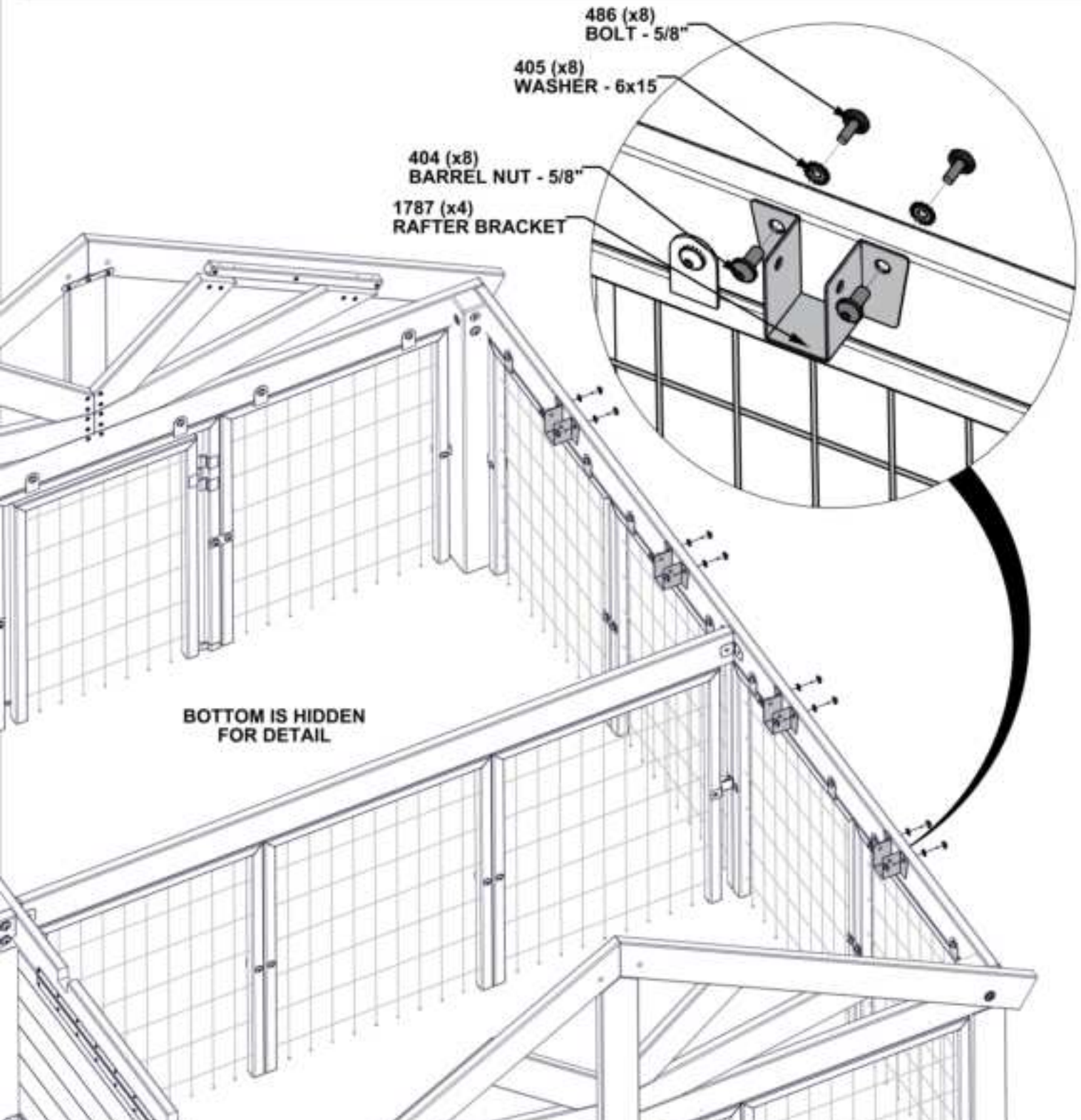

STEP 52 - ANIMAL ENCLOSURE ASSY

QTY	PART NUMBER	DESCRIPTION
4	H100663	BOLT WH 5/16x3/4 BLK
4	H100469	NUT BARREL WH 5/16X5/8 BLK
4	H100198	WASHER LOCK EXT 8x19

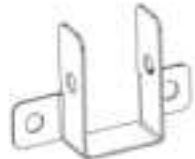

A4M01148 TRUSS BRACKET (x2)

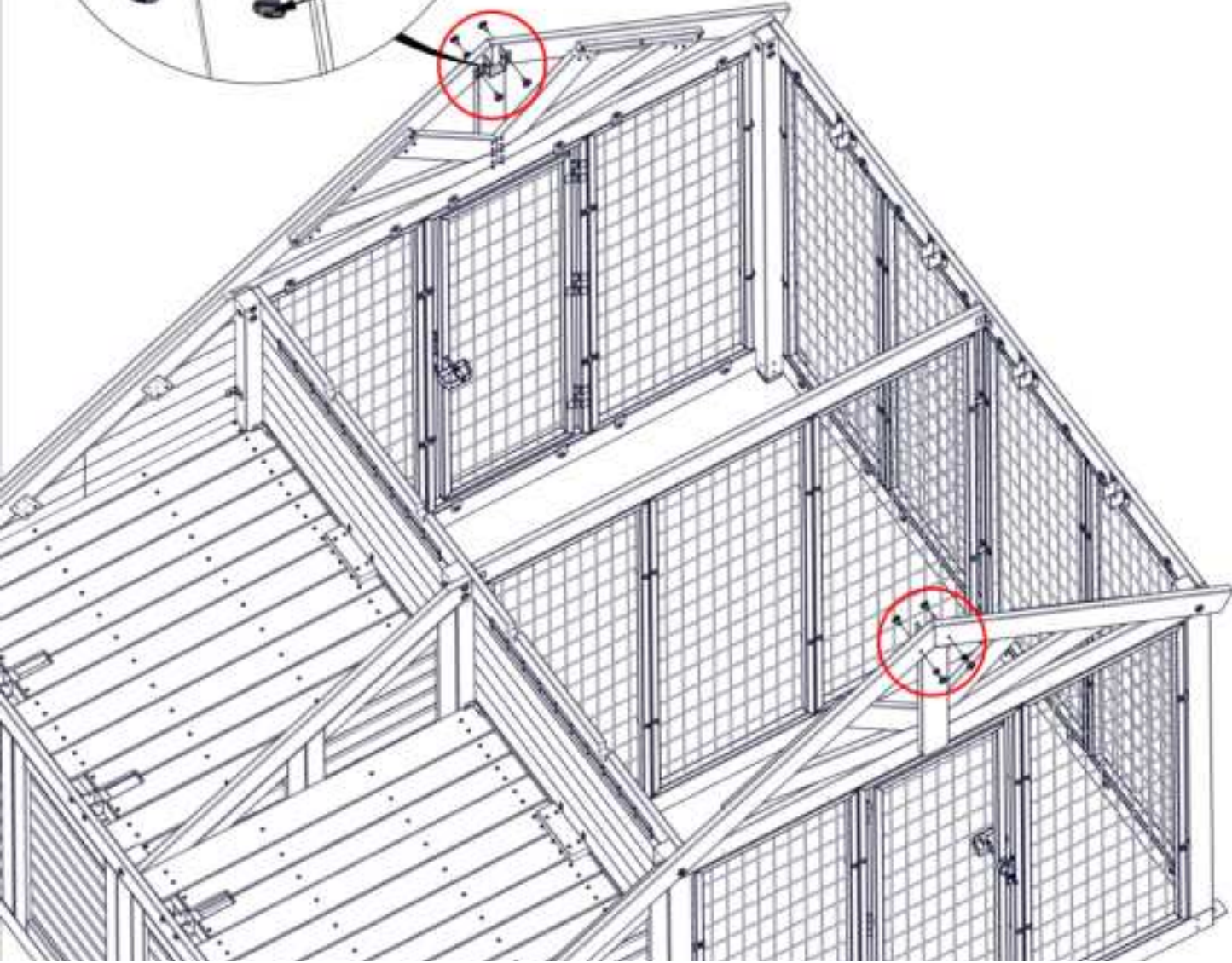
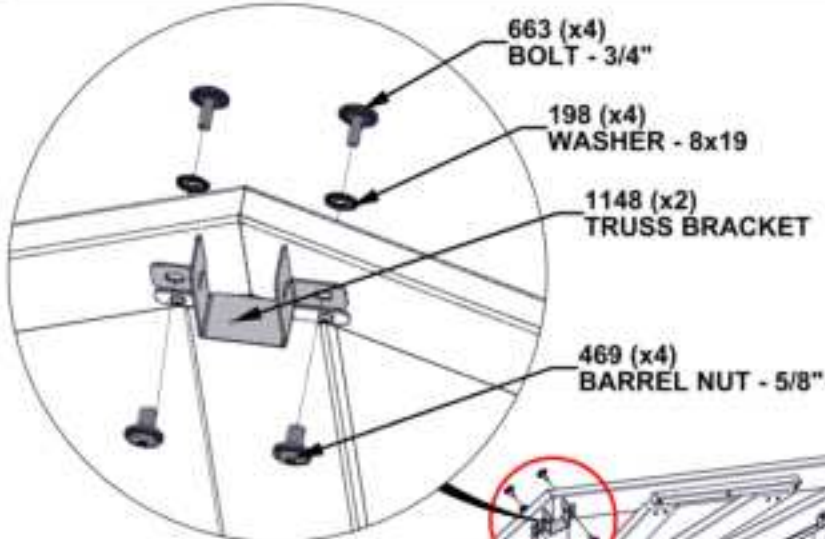

STEP 53 A - ROOF PANEL A ASSEMBLY

ROOF PANEL A

- USE THIS STEP TO FAMILIARIZE YOURSELF WITH THE ROOF PANEL AND ASSIST YOU IN STEPS 53 - 55.
- REMOVE PROTECTIVE BLUE FILM.
- START AT END INDICATED AND ASSEMBLE IN THE DIRECTIONS OF THE ARROW.
- **GLOVES SHOULD BE WORN WHEN HANDLING ROOF PANELS. EDGES ARE SHARP.**

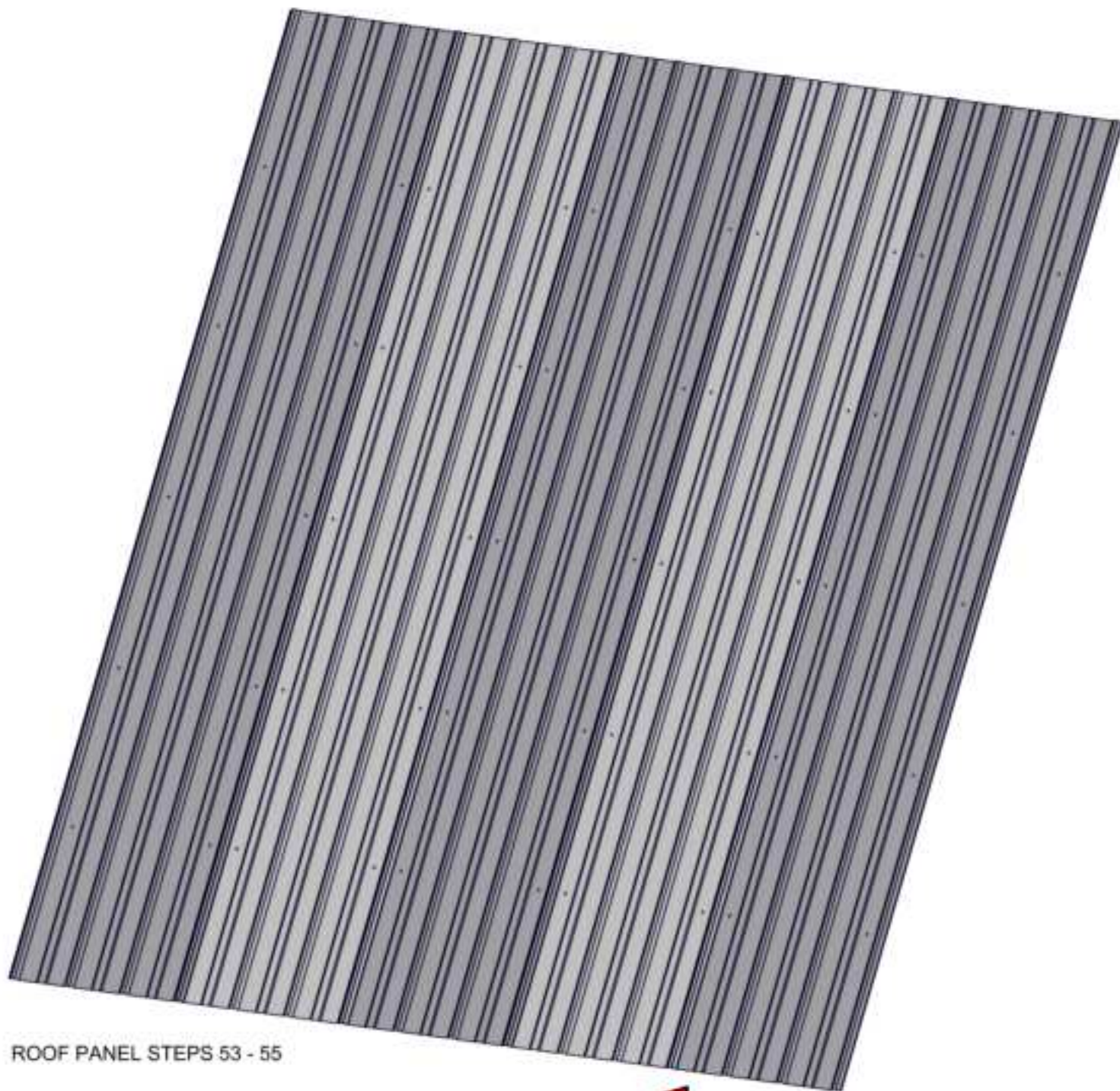

ROOF PANEL STEPS 53 - 55

STEP 53 B - ROOF PANEL A ASSEMBLY

QTY	PART NUMBER	DESCRIPTION
8	H100391	SCREW PFH 8x2 BLK
20	H100382	SCREW PFH 8x1 3/4 BLK



H27 SHEATHING BOARD - W4L22532
(x5) 15/16"x3 3/8"x88 13/16" (24x86x2256)



E2 RAFTER - W4L22526
(x4) 1 7/16"x3 3/8"x85 1/16" (36x86x2160)



H22 RIDGE BEAM - W4L22531
(x1) 15/16"x3 3/8"x88 3/4" (24x86x2254)

HAND TIGHTEN ONLY

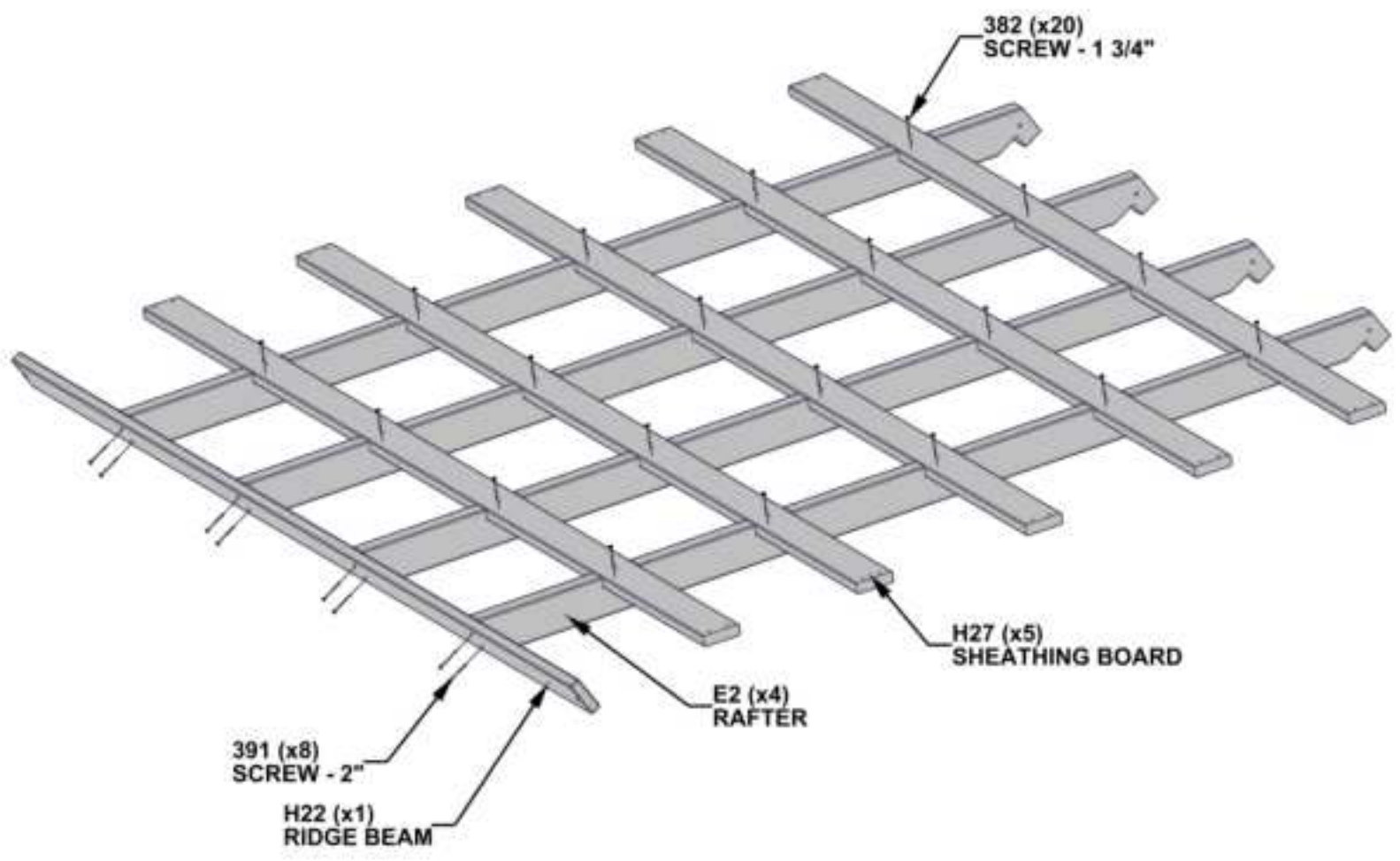

STEP 53C - ROOF PANEL ASSEMBLY

- CRITICAL:**
- SQUARE UNIT BEFORE PROCEEDING TO NEXT STEP.
 - THE BELOW DIMENSIONS ARE CRITICAL TO THE FINAL ROOF ASSEMBLY.
 - MEASUREMENTS SHOULD BE HELD WITHIN +/- 1/4" (6mm).
 - MEASUREMENTS OUTSIDE OF THE TOLERANCE WILL LEAD TO THE INABILITY TO ASSEMBLE THE ROOF.

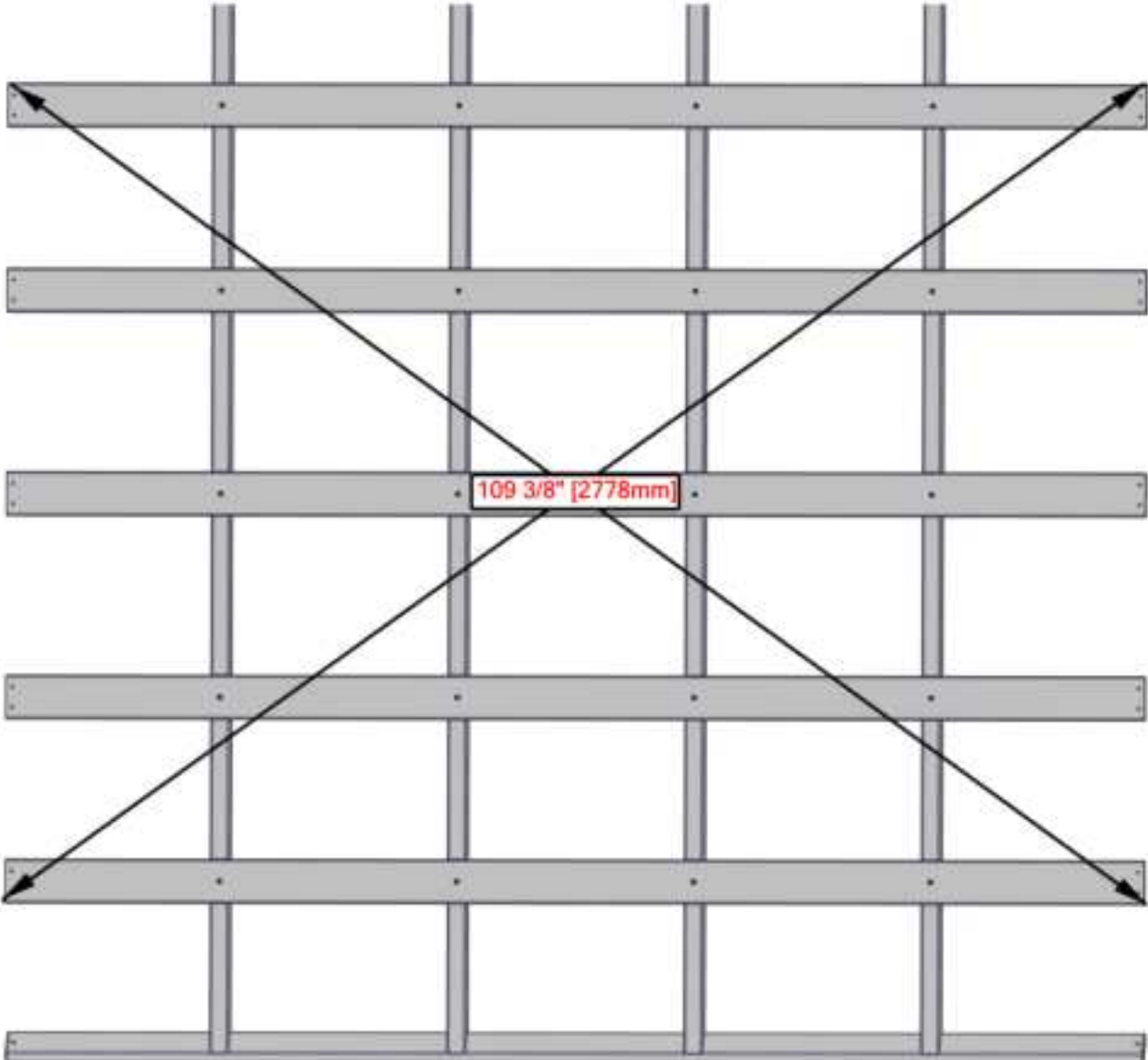

ONCE PANEL IS SQUARED, FULLY TIGHTEN SCREWS.

STEP 54 - ROOF ASSEMBLY

QTY	PART NUMBER	DESCRIPTION
4	H101133	WASHER FLAT 7x14 BLK
4	H100653	NUT LOCK 1/4 BLK
4	H100488	BOLT WH 1/4x2 BLK
20	H100382	SCREW PFH 8x1 3/4 BLK



ROOF PANEL ASSEMBLY (LONG SIDE)
(x1) (FROM STEP 53)

- USE PILOT HOLES TO ALIGN SCREWS

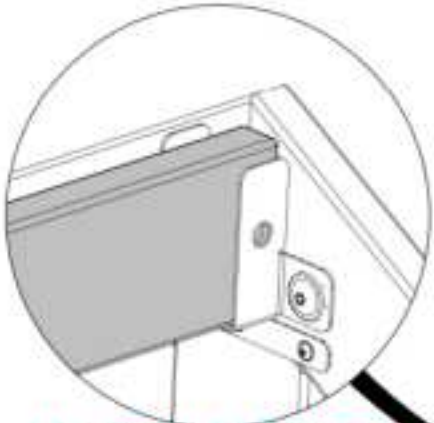

ALIGN TRUSS IN BRACKET
AS SHOWN BOTH ENDS
OF TRUSS

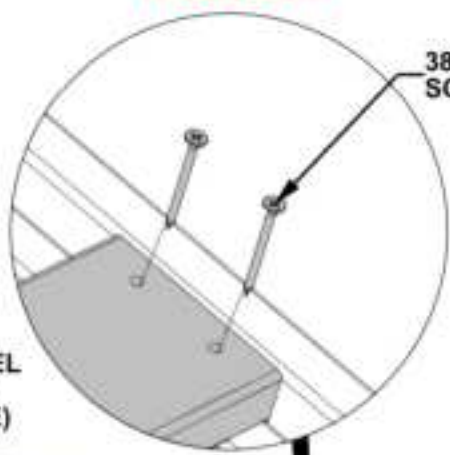

10 LOCATIONS

382 (x20)
SCREW - 1 3/4"

(1x)
ROOF PANEL
ASSEMBLY
(LONG SIDE)

653 (x4)
LOCK NUT - 1/4"

1133 (x4)
WASHER 7x14

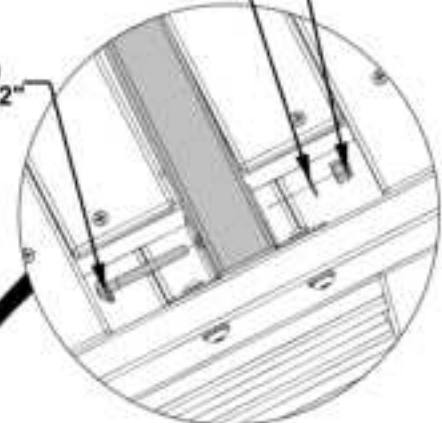

4 LOCATIONS

488 (x4)
BOLT - 2"

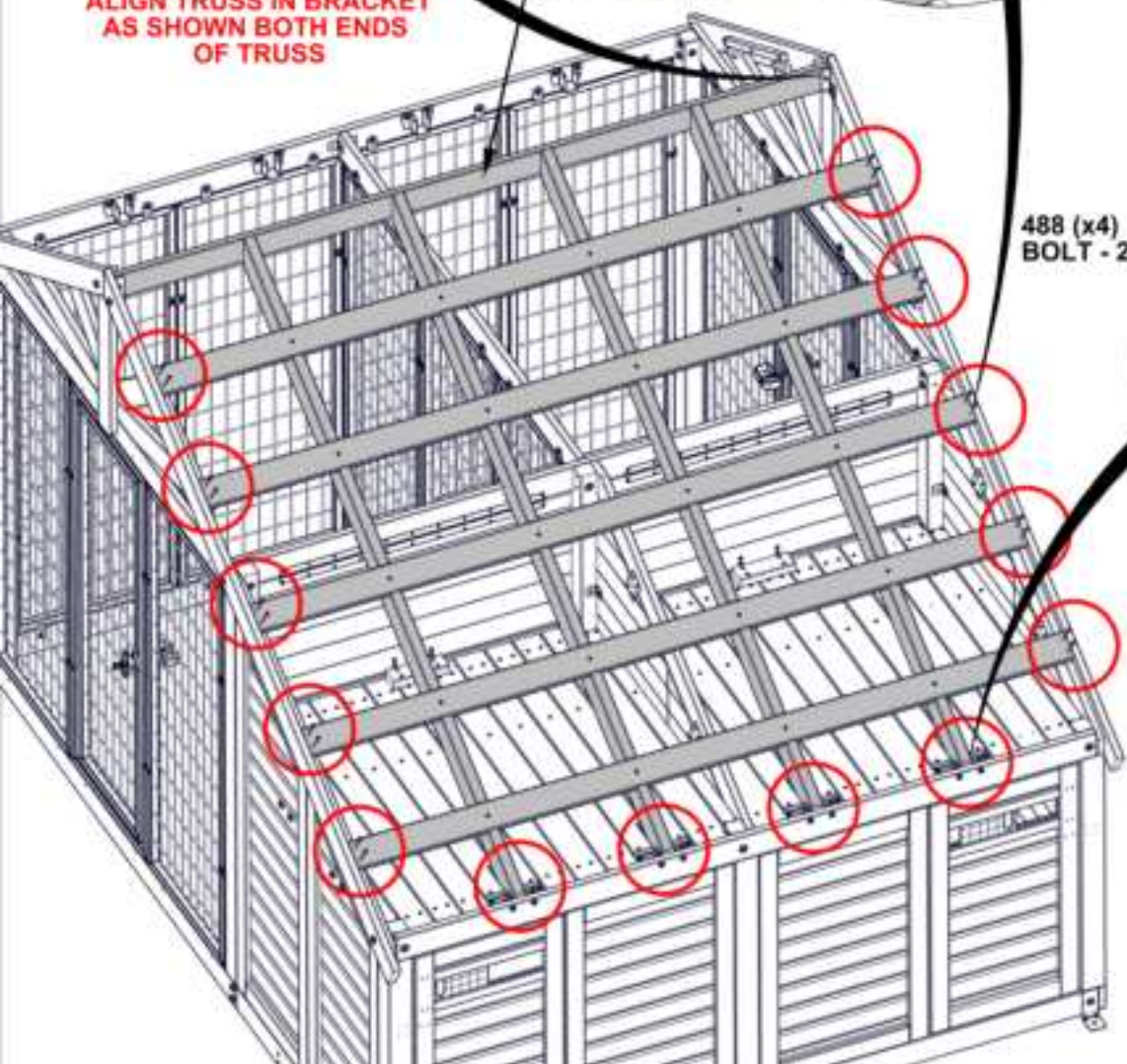

STEP 55A - ROOF ASSEMBLY

QTY	PART NUMBER	DESCRIPTION
10	H101117	SCREW WOODGRIP 10-16x3/4" BLK



A4M06808 29 GA SHEETING (x2)

- MAKE SURE YOUR ROOF PANEL IS SQUARE BEFORE MOVING ON

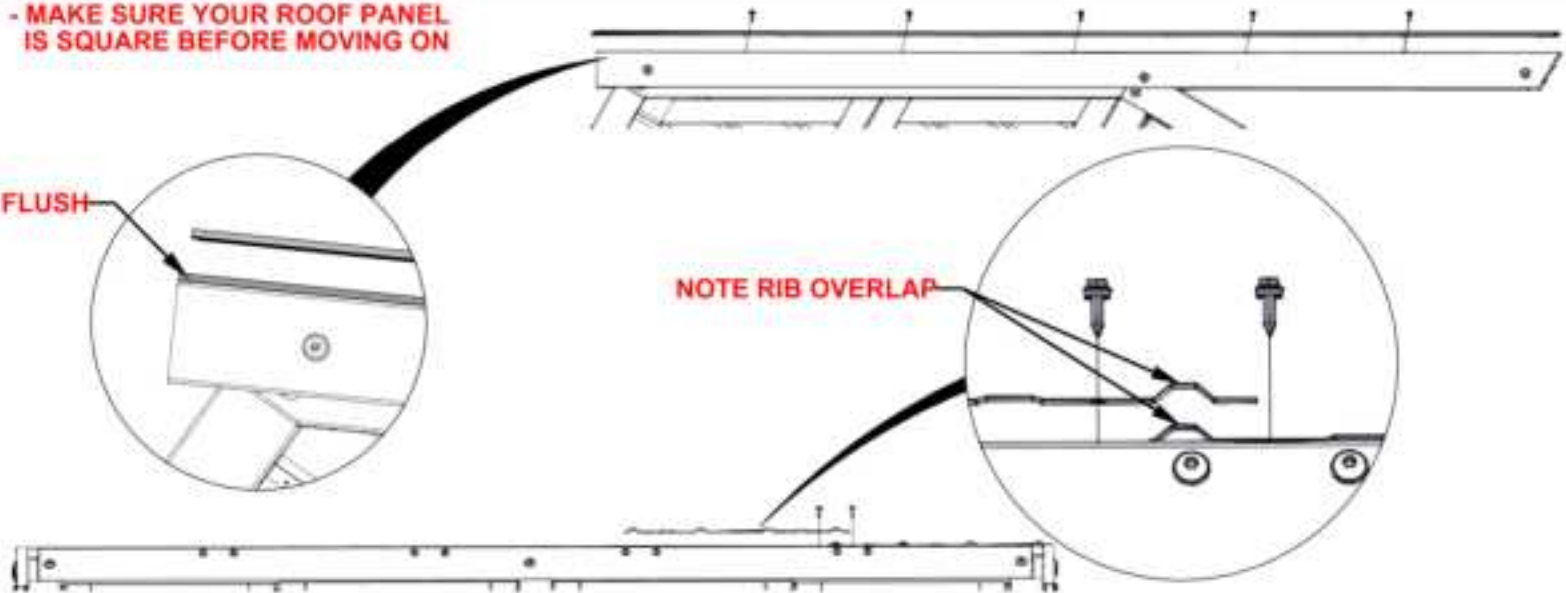

BOTTOM IS HIDDEN FOR DETAIL

1117 (x10)
SCREW WOODGRIP

6808 (x2)
29 GA SHEETING



BOTTOM IS HIDDEN FOR DETAIL

PLACE SHEETING ON ROOF PANEL, ALIGN EDGE OF SHEET 1/2" [12mm] FROM END OF BOARD.

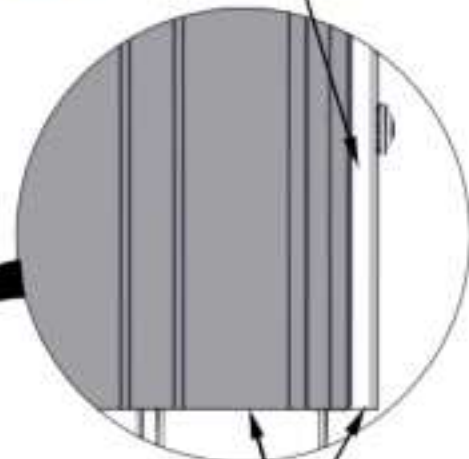

FLUSH BTM OF SHEET WITH END OF BOARD

STEP 55B - ROOF ASSEMBLY

QTY	PART NUMBER	DESCRIPTION
30	H101117	SCREW WOODGRIP 10-16x3/4" BLK



A4M06808 29 GA SHEETING
(x3)

NOTE RIB OVERLAP

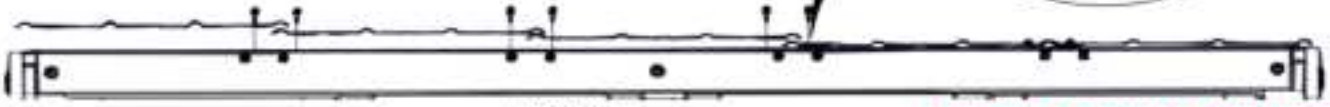
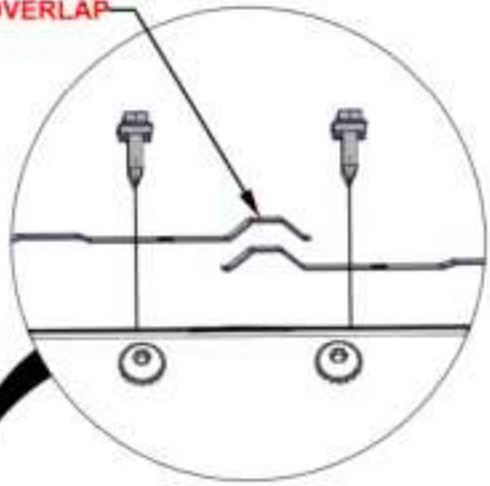

1117 (x30)
SCREW WOODGRIP

6808 (x3)
29 GA SHEETING

**ENSURE CORRECT PLACEMENT
OF 6808 STEEL SHEETING.**

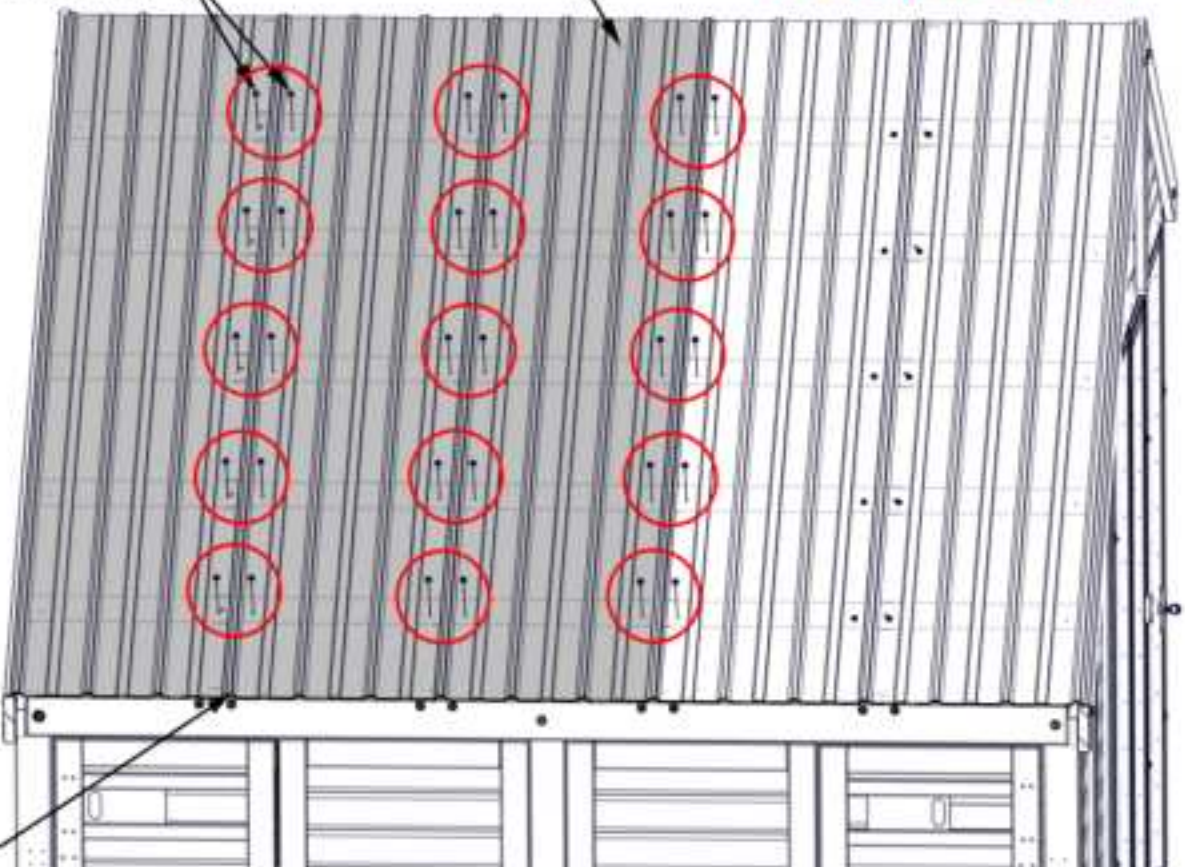

**ENDS OF ALL SHEETS
SHOULD BE FLUSH**

STEP 55C - ROOF ASSEMBLY

QTY	PART NUMBER	DESCRIPTION
10	H101117	SCREW WOODGRIP 10-16x3/4" BLK

1117 (x10)
SCREW WOODGRIP

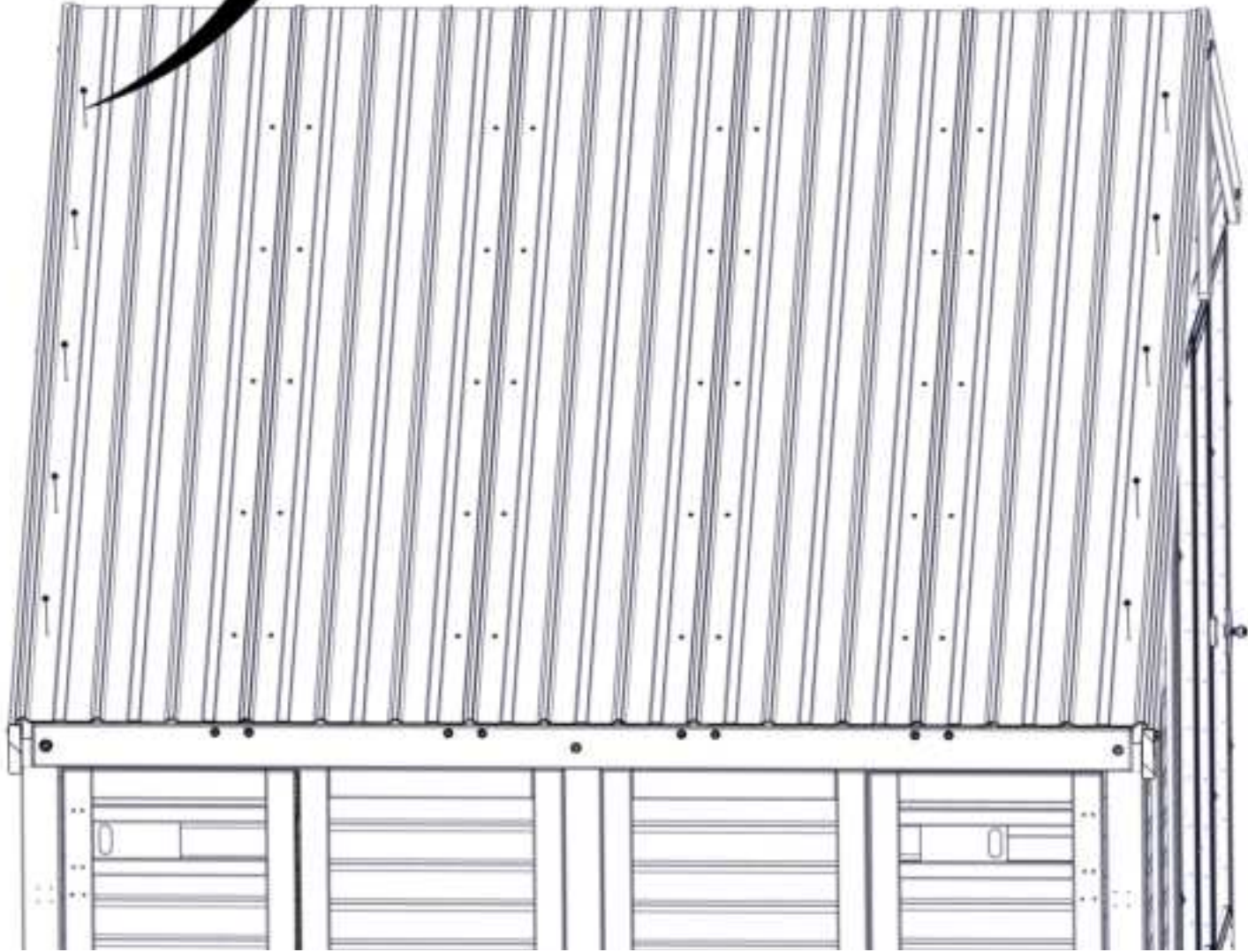
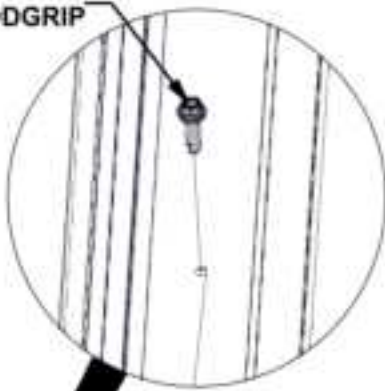

STEP 56 A - ROOF PANEL B ASSEMBLY

ROOF PANEL B

- USE THIS STEP TO FAMILIARIZE YOURSELF WITH THE ROOF PANEL AND ASSIST YOU IN STEPS 56 - 58.
- REMOVE PROTECTIVE BLUE FILM.
- START AT THE END INDICATED AND ASSEMBLE IN THE DIRECTIONS OF THE ARROW.
- **GLOVES SHOULD BE WORN WHEN HANDLING ROOF PANELS. EDGES ARE SHARP.**

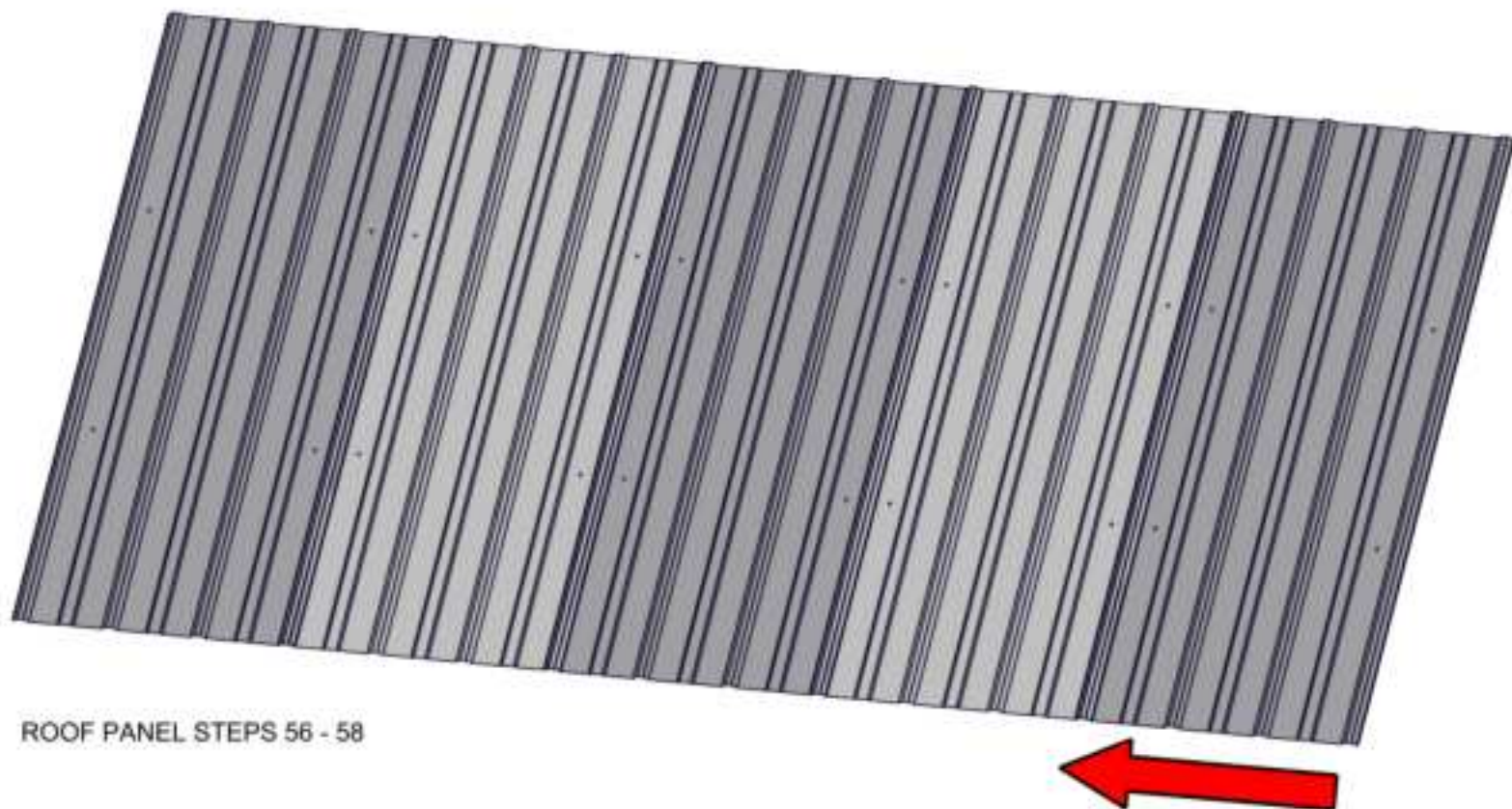

ROOF PANEL STEPS 56 - 58

STEP 56 B - ROOF PANEL B ASSEMBLY

QTY	PART NUMBER	DESCRIPTION
8	H100391	SCREW PFH 8x2 BLK
8	H100382	SCREW PFH 8x1 3/4 BLK



H27 SHEATHING BOARD - W4L22532
(x2) 15/16"x3 3/8"x88 13/16" (24x86x2256)

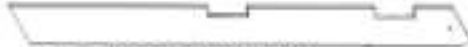

E1 RAFTER - W4L22530
(x4) 1 7/16"x3 3/8"x40 1/16" (36x86x1017)



H22 RIDGE BEAM - W4L22531
(x1) 15/16"x3 3/8"x88 3/4" (24x86x2254)

- USE PILOT HOLES TO ALIGN SCREWS
HAND TIGHTEN ONLY

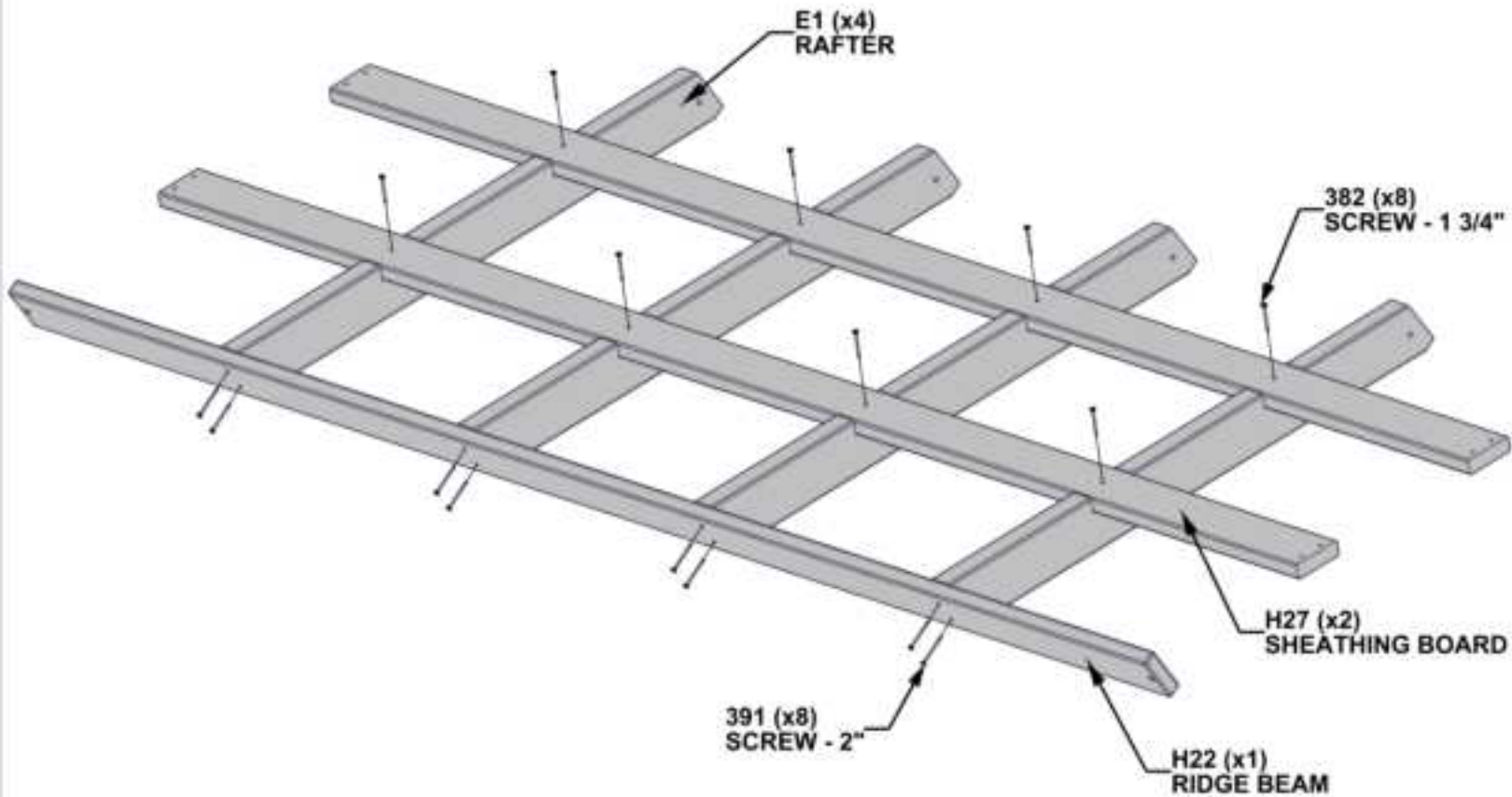

STEP 56 C - ROOF PANEL B ASSEMBLY

CRITICAL:

- SQUARE UNIT BEFORE PROCEEDING TO NEXT STEP.
- THE BELOW DIMENSIONS ARE CRITICAL TO THE FINAL ROOF ASSEMBLY.
- MEASUREMENTS SHOULD BE HELD WITHIN $\pm 1/4"$ (6mm).
- MEASUREMENTS OUTSIDE OF THE TOLERANCE WILL LEAD TO THE INABILITY TO ASSEMBLE THE ROOF.

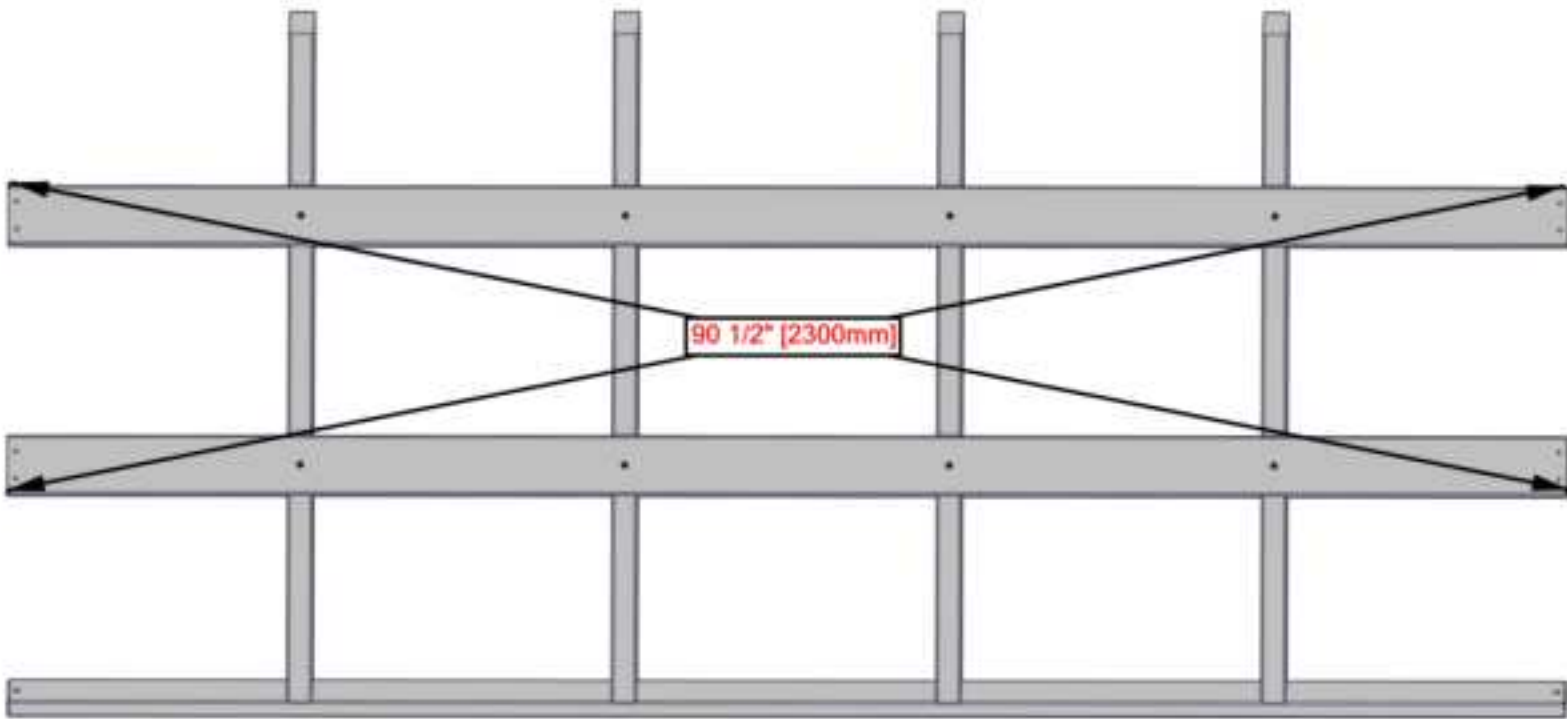

ONCE PANEL IS SQUARED, FULLY TIGHTEN SCREWS.

STEP 57 - ROOF ASSEMBLY

QTY	PART NUMBER	DESCRIPTION
4	H101133	WASHER FLAT 7x14 BLK
4	H100653	NUT LOCK 1/4 BLK
4	H100488	BOLT WH 1/4x2 BLK
2	H100469	NUT BARREL WH 5/16x5/8 BLK
8	H100382	SCREW PFH 8x1 3/4 BLK
2	H100378	BOLT WH 5/16x1 3/4 BLK

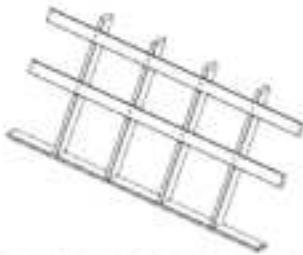

ROOF PANEL ASSEMBLY (SHORT SIDE)
(x1) (FROM STEP 56)

- USE PILOT HOLES TO ALIGN SCREWS

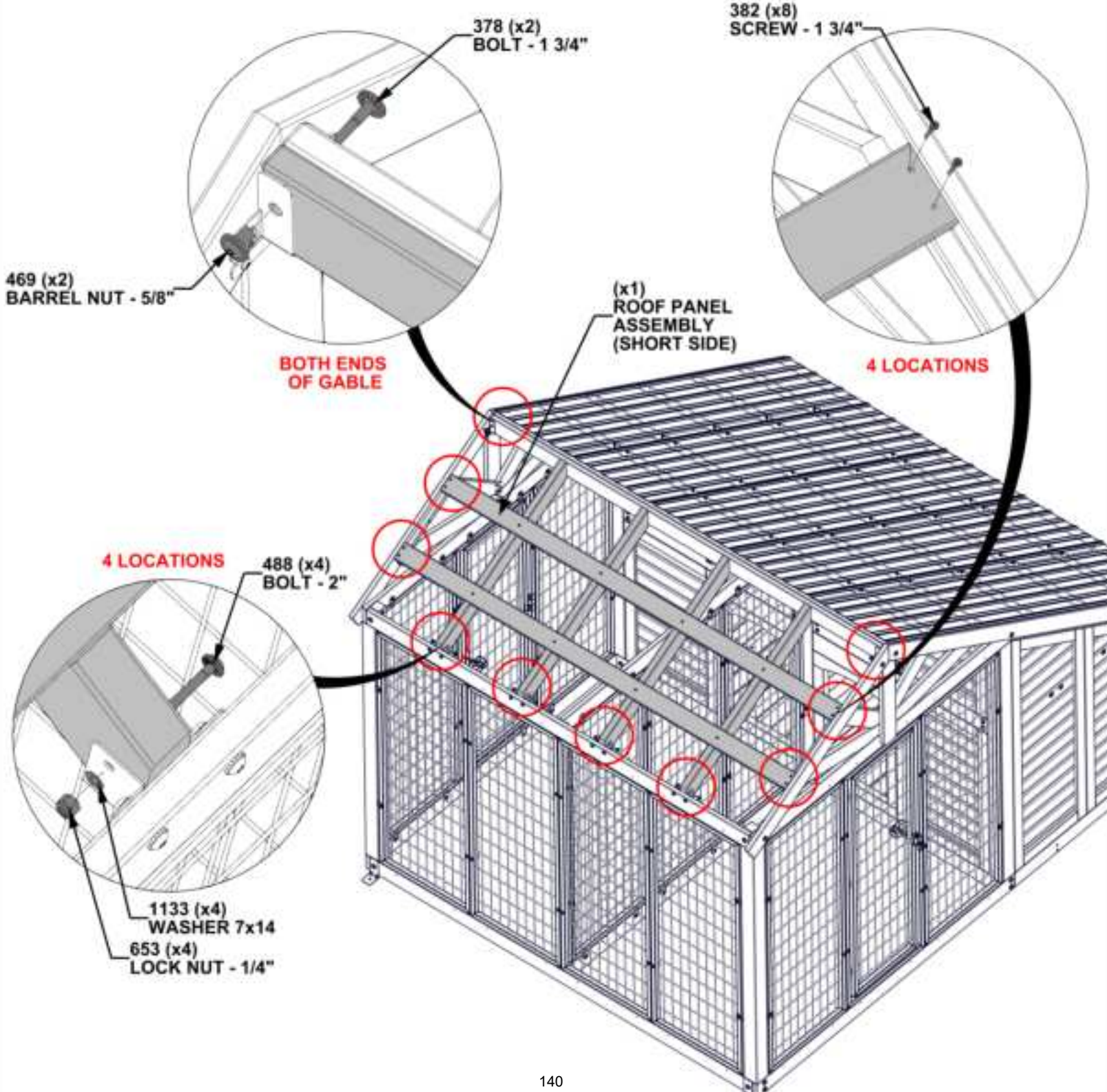

STEP 58 A - ROOF ASSEMBLY

QTY	PART NUMBER	DESCRIPTION
4	H101117	SCREW WOODGRIP 10-16x3/4" BLK



A4M06814 29 GA SHEETING (x2)

- MAKE SURE YOUR ROOF PANEL IS SQUARE BEFORE MOVING ON.

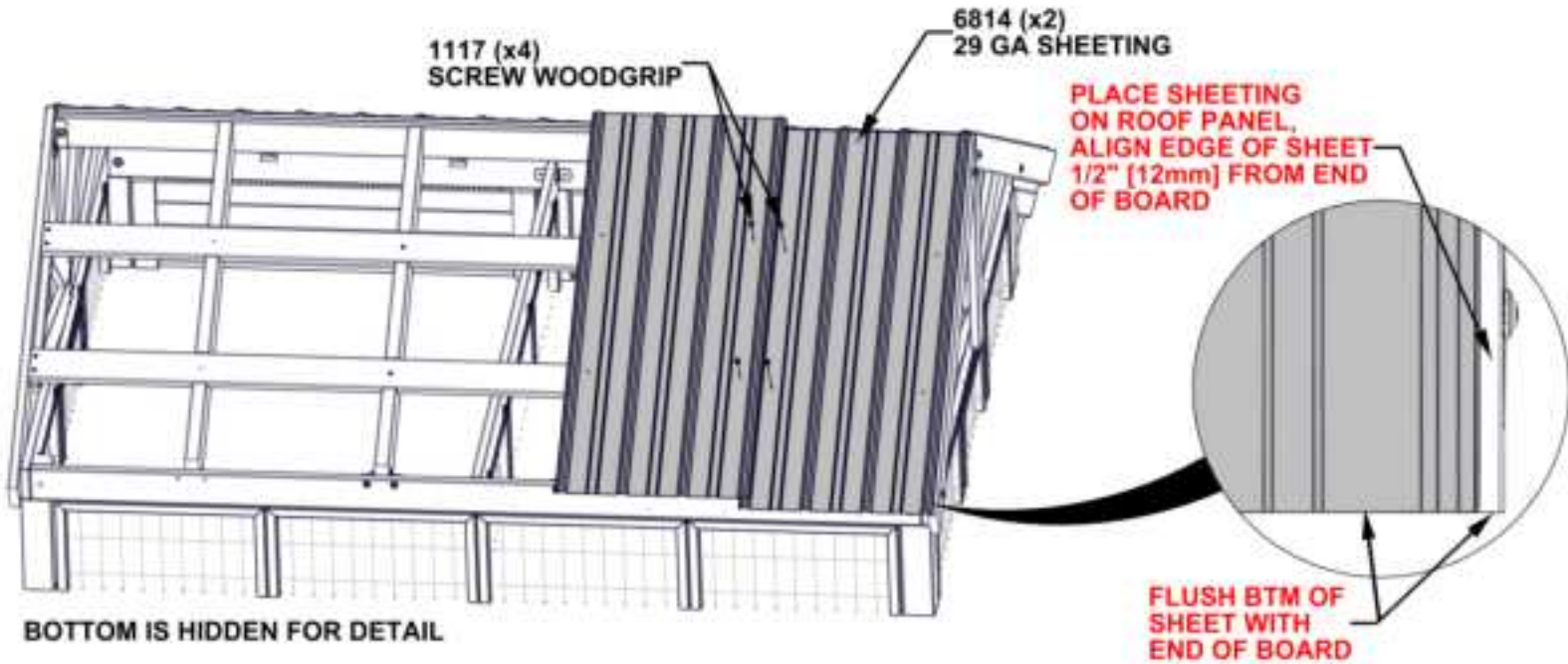
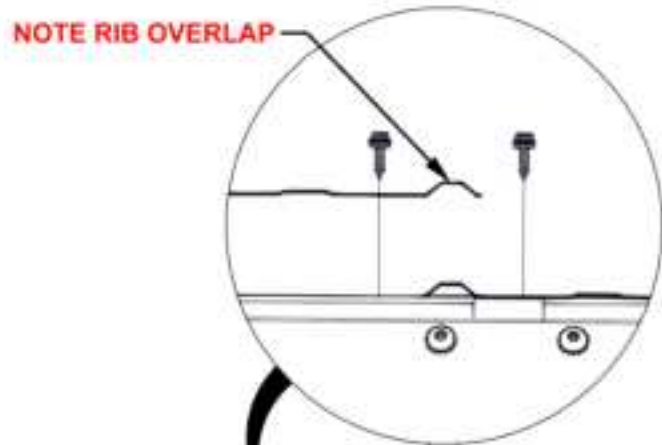
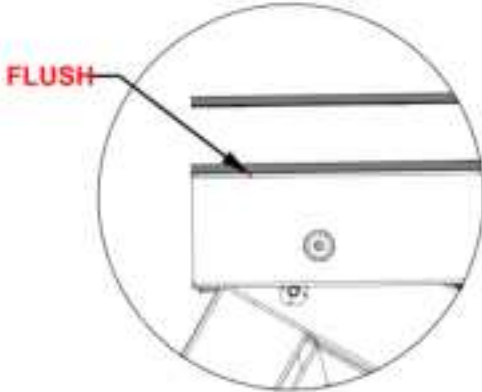

BOTTOM IS HIDDEN FOR DETAIL

STEP 58B - ROOF ASSEMBLY

QTY	PART NUMBER	DESCRIPTION
12	H101117	SCREW WOODGRIP 10-16x3/4" BLK



A4M06814 29 GA SHEETING (x3)

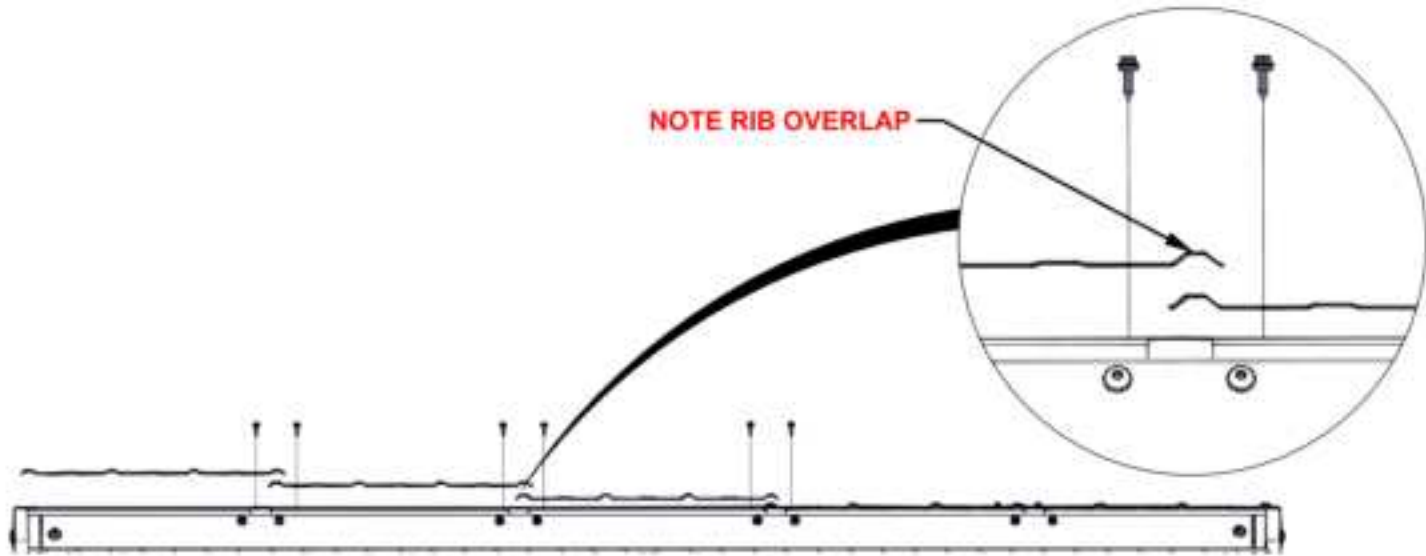

ENSURE CORRECT PLACEMENT OF 6814 STEEL SHEETING.

1117 (x12) SCREW WOODGRIP

6814 (x3) 29 GA SHEETING

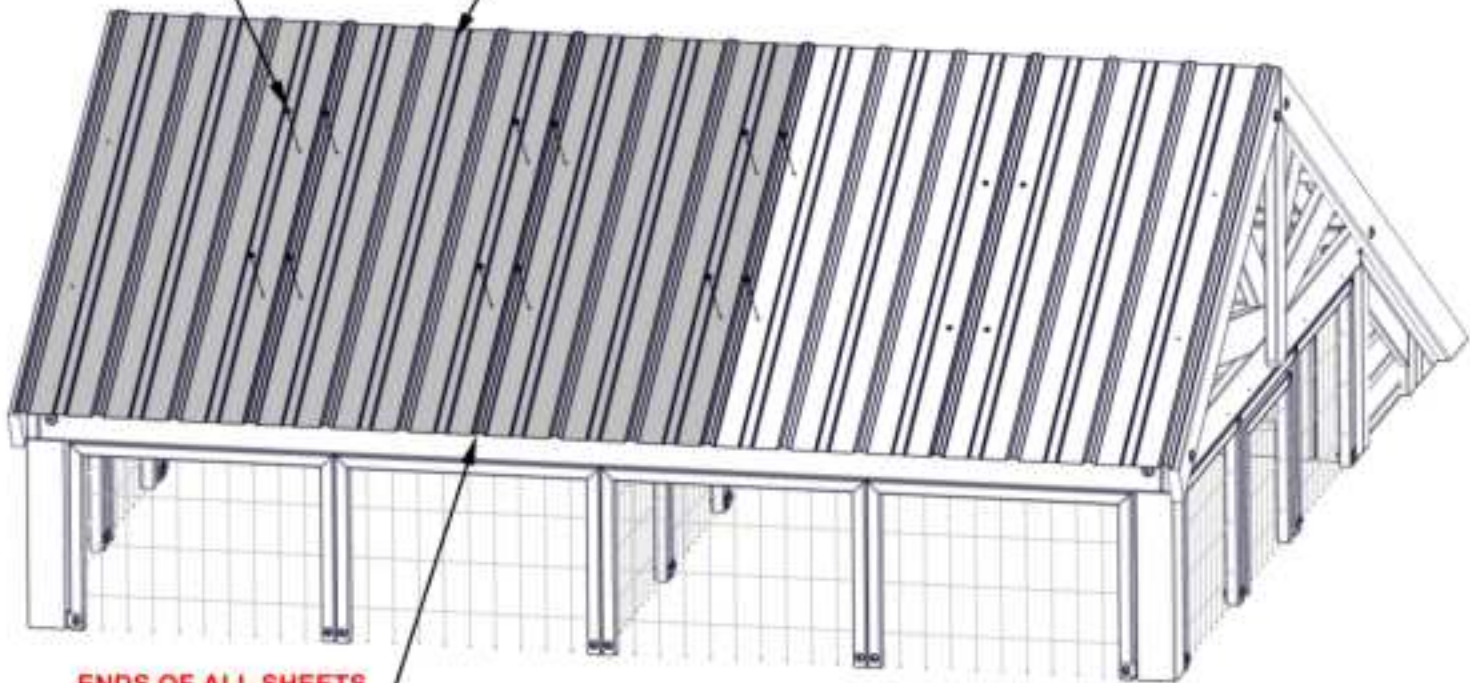

BOTTOM IS HIDDEN FOR DETAIL

STEP 58C - ROOF ASSEMBLY

QTY	PART NUMBER	DESCRIPTION
4	H101117	SCREW WOODGRIP 10-16x3/4" BLK

1117 (x4)
SCREW WOODGRIP

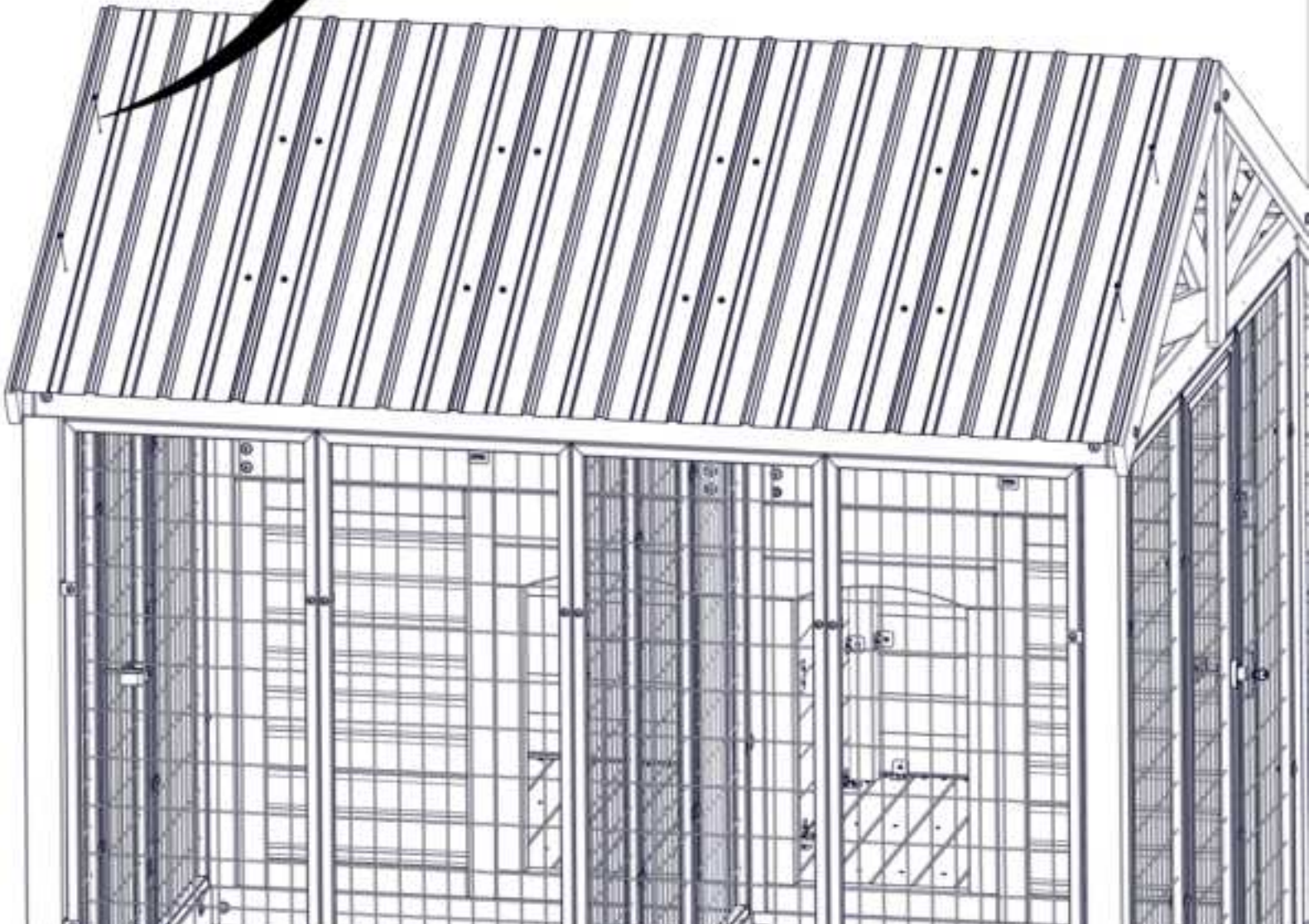
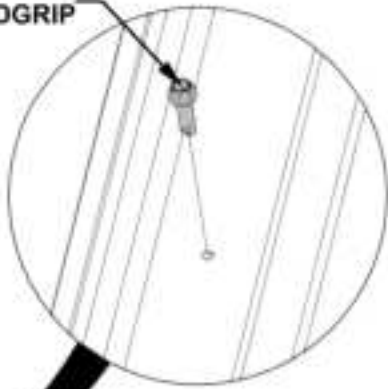

STEP 59A - ROOF ASSEMBLY

QTY	PART NUMBER	DESCRIPTION
4	H101116	SCREW SELF TAPPING 1/4x1 BLK



- DUE TO MULTIPLE LAYERS OF METAL ON THE EDGE TRIM, IT IS RECOMMENDED THAT A 1/8" [3mm] DRILL BIT IS USED TO CREATE STARTER HOLES.
- REMOVE PROTECTIVE BLUE FILM.
- **GLOVES SHOULD BE WORN WHEN HANDLING ROOF METAL. EDGES ARE SHARP.**

1116 (x4)
SELF TAPPING SCREW

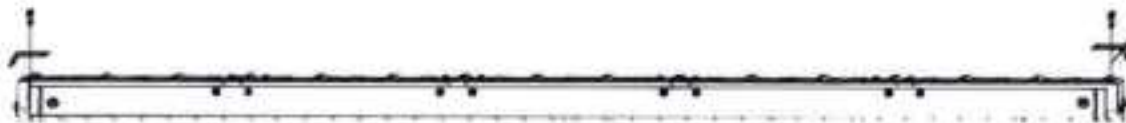
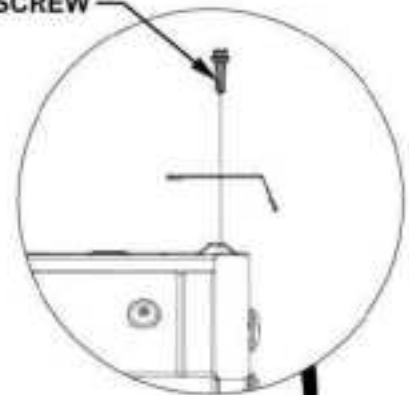

6811 (x1)
ROOF EDGE TRIM

6810 (x1)
ROOF EDGE TRIM

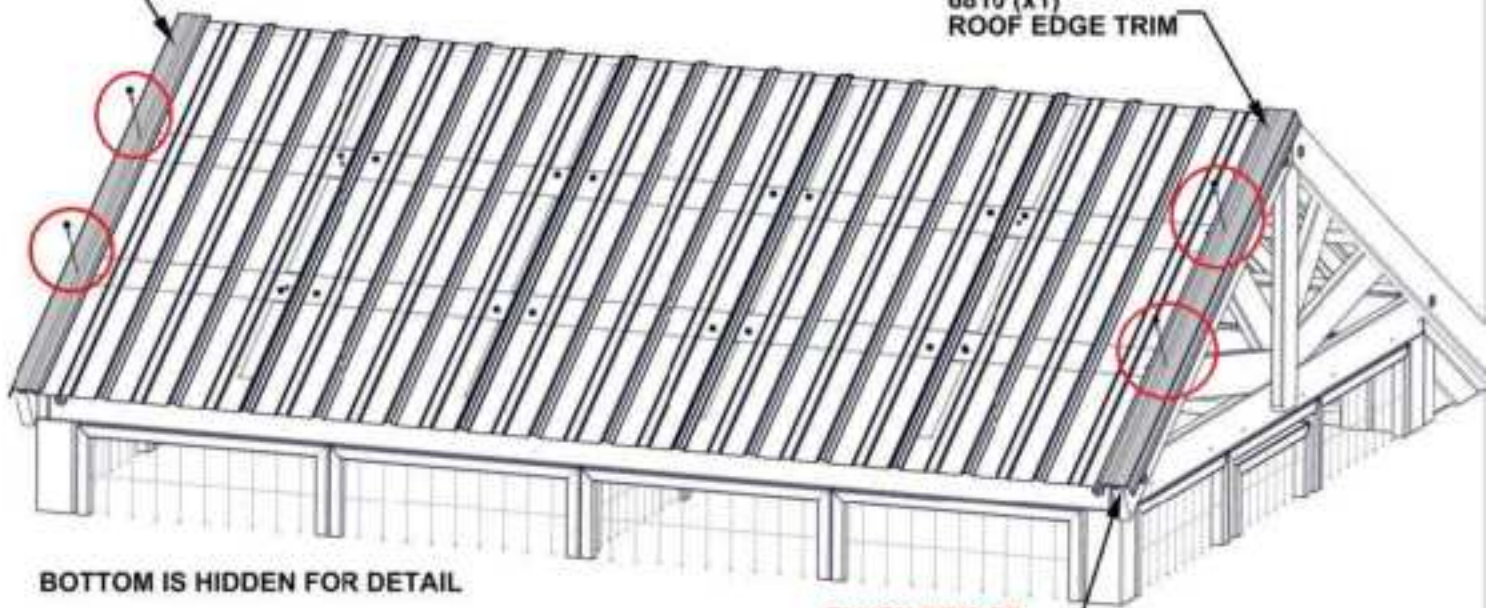

BOTTOM IS HIDDEN FOR DETAIL

**FLUSH BTM OF
EDGE TRIM WITH
END OF BOARD**

STEP 59B - ROOF ASSEMBLY

QTY	PART NUMBER	DESCRIPTION
4	H101116	SCREW SELF TAPPING 1/4x1 BLK



A4M06809 ROOF EDGE TRIM
(x1)

- DUE TO MULTIPLE LAYERS OF METAL ON THE EDGE TRIM, IT IS RECOMMENDED THAT A 1/8" [3mm] DRILL BIT IS USED TO CREATE STARTER HOLES.
- REMOVE PROTECTIVE BLUE FILM.
- **GLOVES SHOULD BE WORN WHEN HANDLING ROOF METAL. EDGES ARE SHARP.**

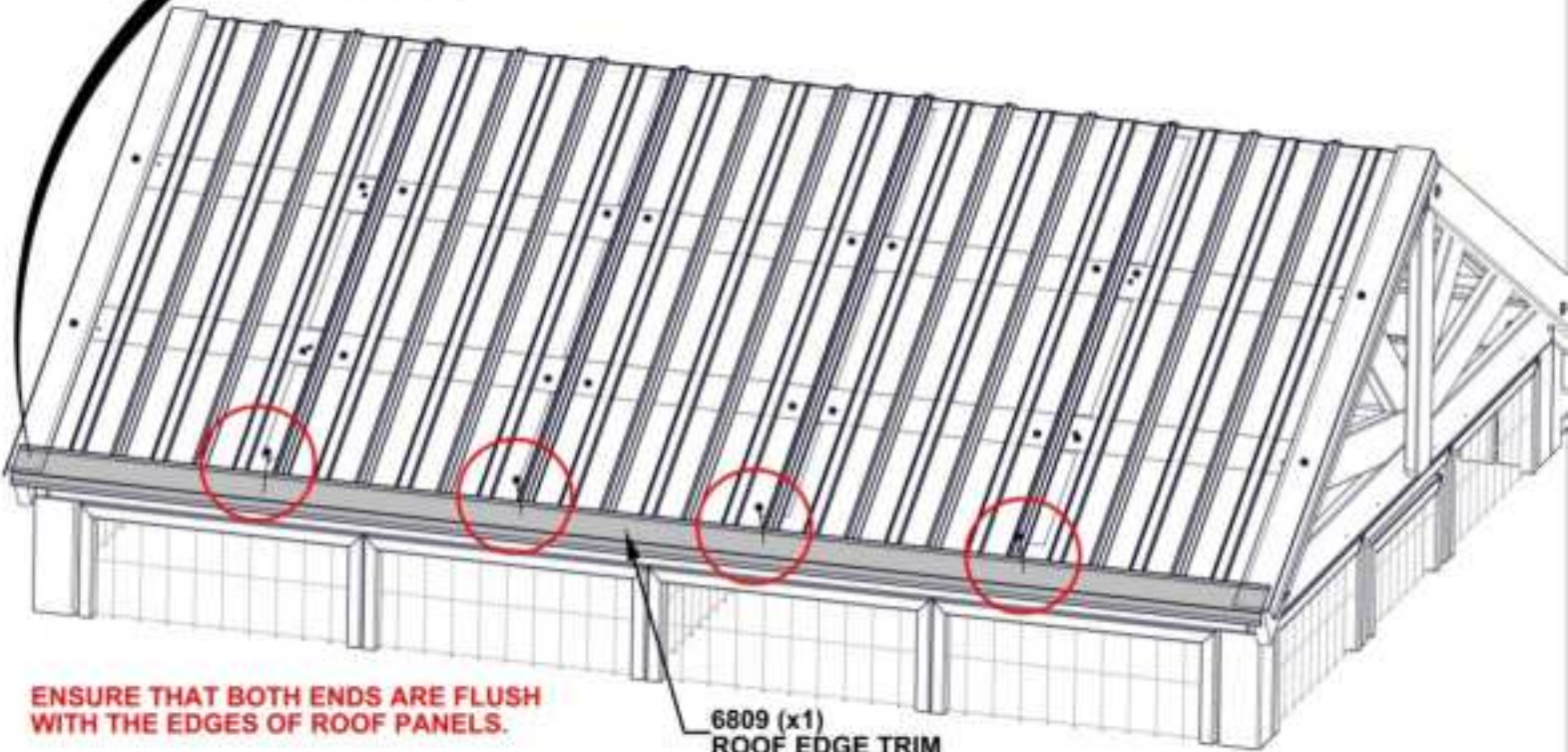
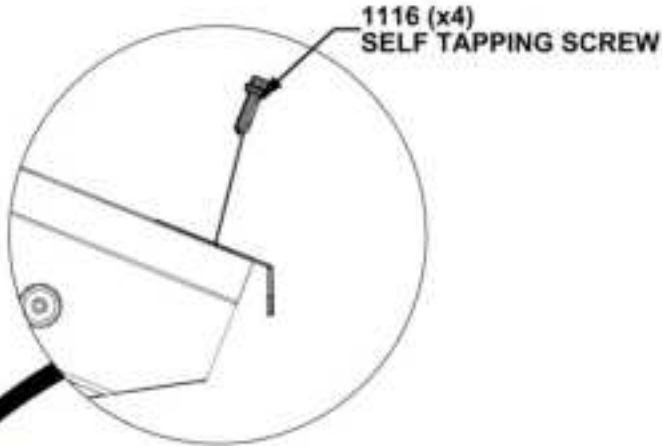

ENSURE THAT BOTH ENDS ARE FLUSH WITH THE EDGES OF ROOF PANELS.

6809 (x1)
ROOF EDGE TRIM

BOTTOM IS HIDDEN FOR DETAIL

STEP 59C - ROOF ASSEMBLY

QTY	PART NUMBER	DESCRIPTION
4	H101116	SCREW SELF TAPPING 1/4x1 BLK

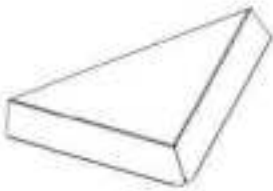

A4M02696 CORNER CAP
(x2)

- DUE TO MULTIPLE LAYERS OF METAL ON THE EDGE TRIM, IT IS RECOMMENDED THAT A 1/8" [3mm] DRILL BIT IS USED TO CREATE STARTER HOLES.
- REMOVE PROTECTIVE BLUE FILM.
- **GLOVES SHOULD BE WORN WHEN HANDLING ROOF METAL. EDGES ARE SHARP.**

1116 (x4)
SCREW SELF TAPPING

2696 (x2)
CORNER CAP

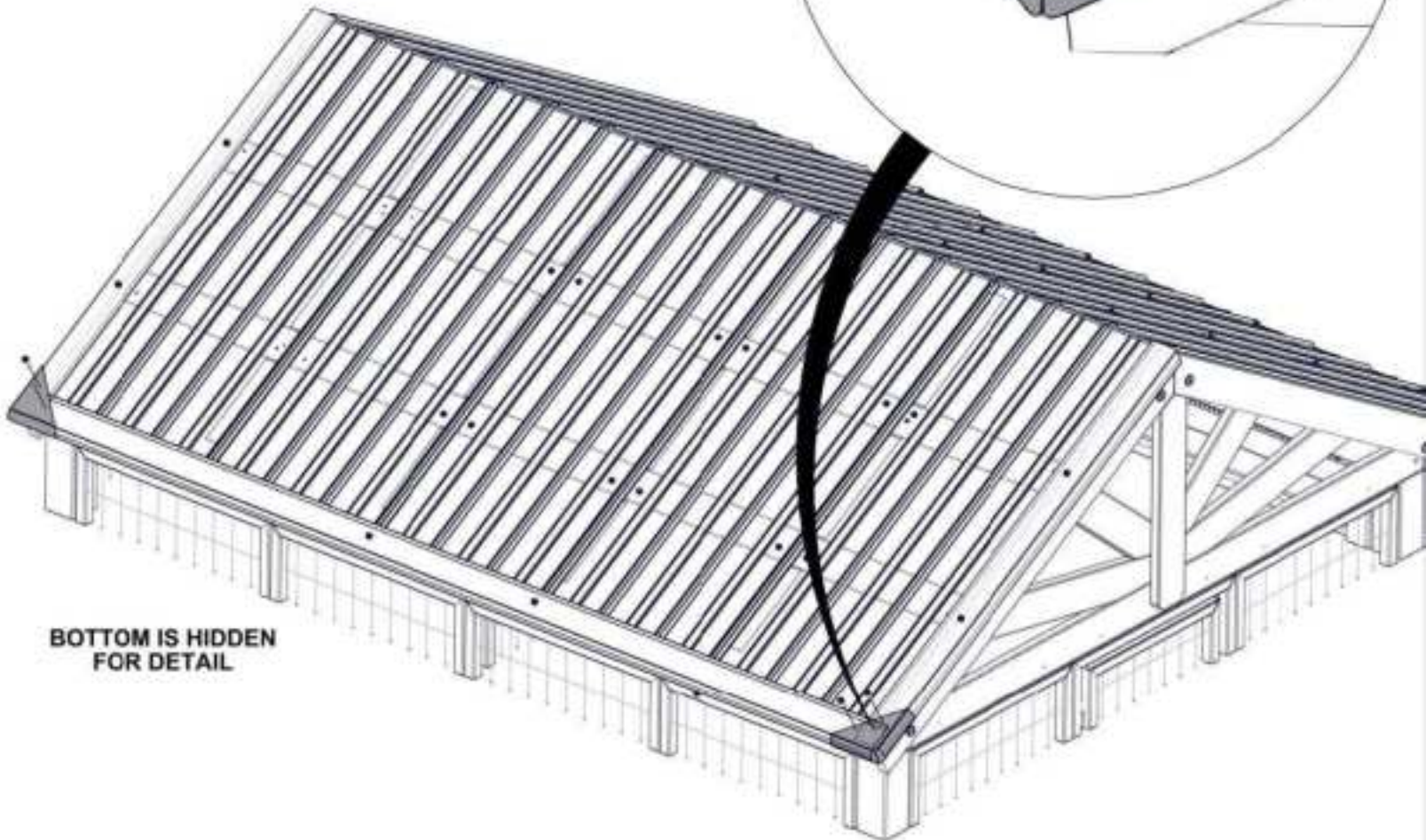
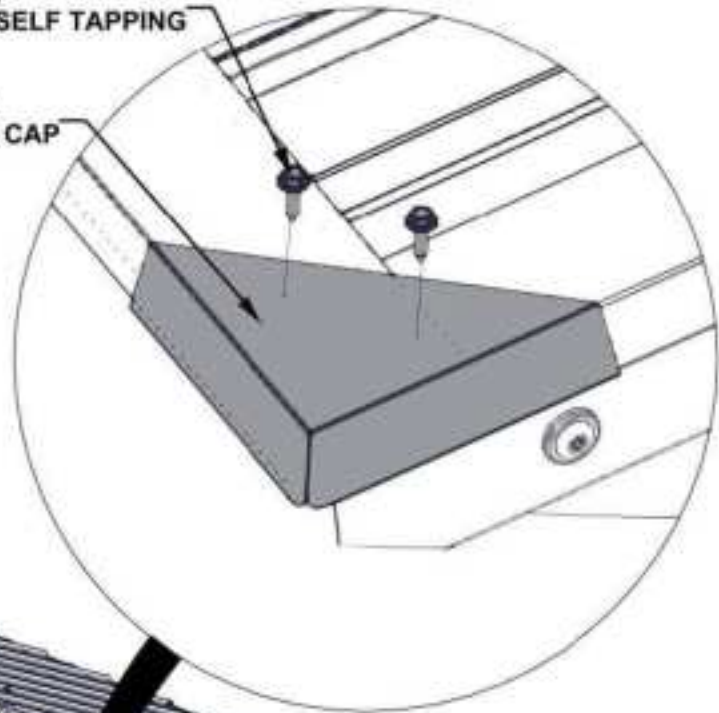

BOTTOM IS HIDDEN
FOR DETAIL

STEP 60A - ROOF ASSEMBLY

QTY	PART NUMBER	DESCRIPTION
10	H101116	SCREW SELF TAPPING 1/4x1 BLK



- DUE TO MULTIPLE LAYERS OF METAL ON THE EDGE TRIM, IT IS RECOMMENDED THAT A 1/8" [3mm] DRILL BIT IS USED TO CREATE STARTER HOLES.
- REMOVE PROTECTIVE BLUE FILM.
- **GLOVES SHOULD BE WORN WHEN HANDLING ROOF METAL. EDGES ARE SHARP.**

1116 (x10)
SCREW SELF TAPPING

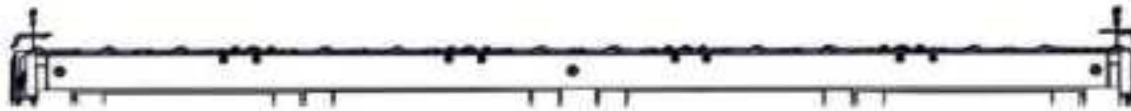
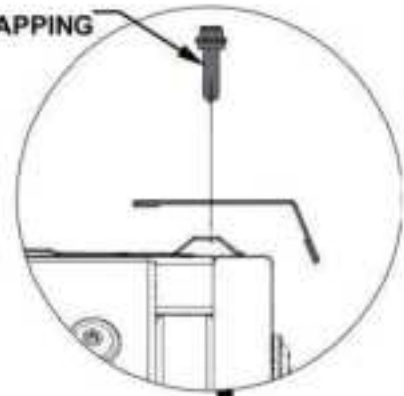

6812 (x1)
ROOF EDGE TRIM

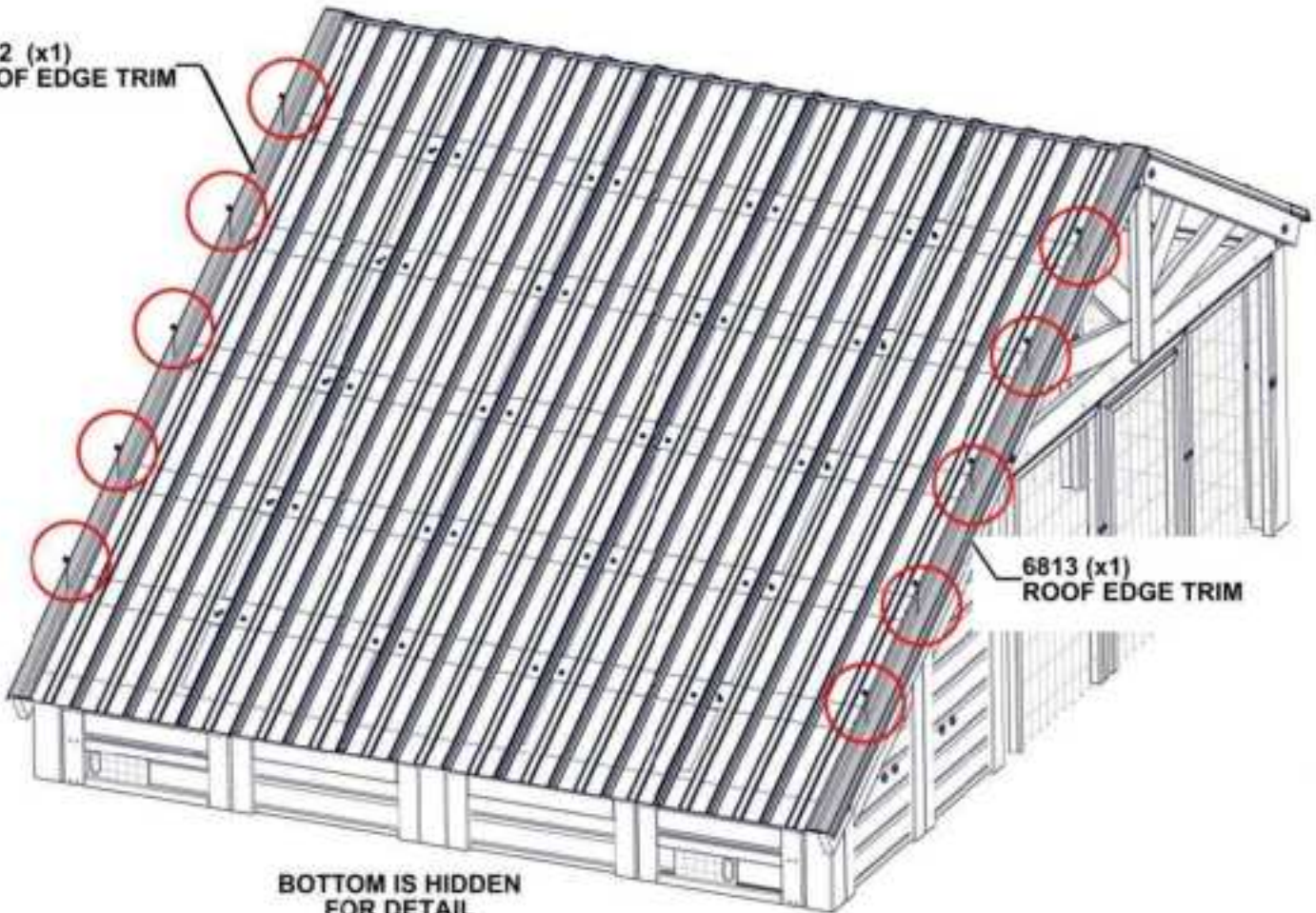

STEP 60B - ROOF ASSEMBLY

QTY	PART NUMBER	DESCRIPTION
4	H101116	SCREW SELF TAPPING 1/4x1 BLK



A4M06809 ROOF EDGE TRIM
(x1)

- DUE TO MULTIPLE LAYERS OF METAL ON THE EDGE TRIM, IT IS RECOMMENDED THAT A 1/8" [3mm] DRILL BIT IS USED TO CREATE STARTER HOLES.
- REMOVE PROTECTIVE BLUE FILM.
- **GLOVES SHOULD BE WORN WHEN HANDLING ROOF METAL. EDGES ARE SHARP.**

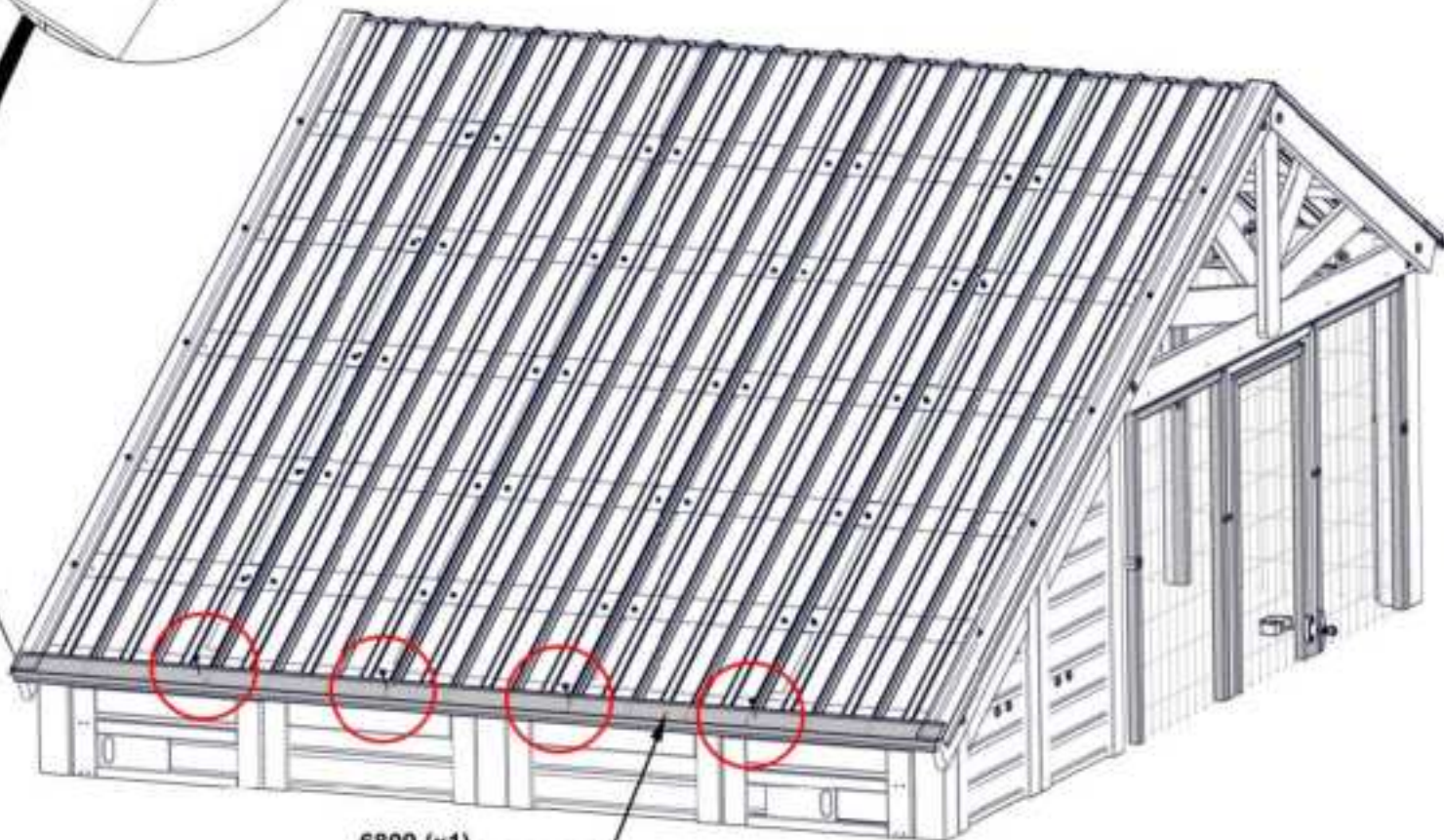
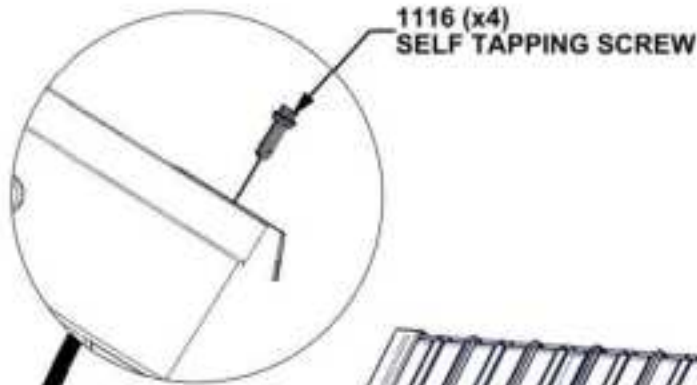

6809 (x1)
ROOF EDGE TRIM

BOTTOM IS HIDDEN
FOR DETAIL

**ENSURE THAT BOTH ENDS ARE FLUSH
WITH THE EDGES OF ROOF PANELS**

STEP 60C - ROOF ASSEMBLY

QTY	PART NUMBER	DESCRIPTION
4	H101116	SCREW SELF TAPPING 1/4x1 BLK



A4M02696 CORNER CAP
(x2)

- DUE TO MULTIPLE LAYERS OF METAL ON THE EDGE TRIM, IT IS RECOMMENDED THAT A 1/8" [3mm] DRILL BIT IS USED TO CREATE STARTER HOLES.
- REMOVE PROTECTIVE BLUE FILM.
- **GLOVES SHOULD BE WORN WHEN HANDLING ROOF METAL. EDGES ARE SHARP.**

1116 (x4)
SCREW SELF TAPPING

696 (x2)
CORNER CAP

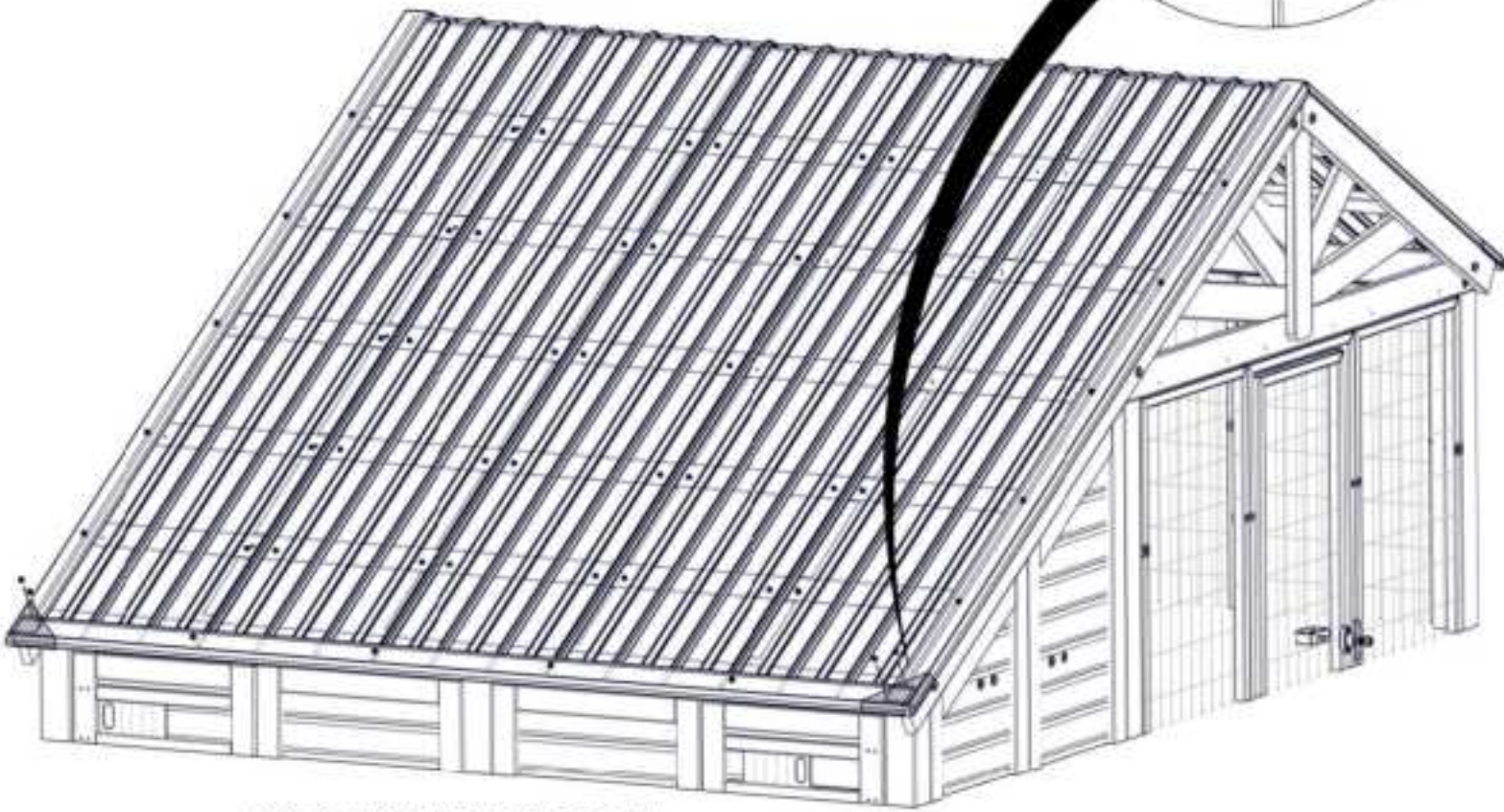
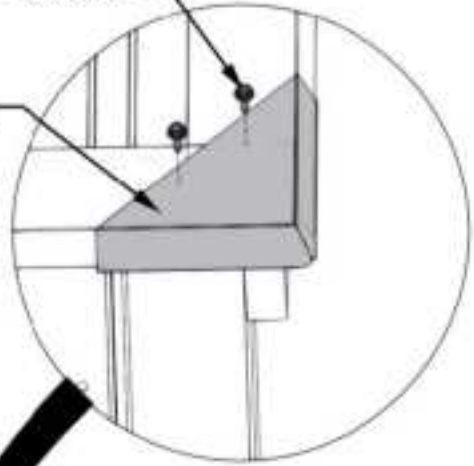

BOTTOM IS HIDDEN FOR DETAIL

STEP 61 - ROOF ASSEMBLY

QTY	PART NUMBER	DESCRIPTION
12	H101116	SCREW SELF TAPPING 1/4x1 BLK



- DUE TO MULTIPLE LAYERS OF METAL ON THE EDGE TRIM, IT IS RECOMMENDED THAT A 1/8" [3mm] DRILL BIT IS USED TO CREATE STARTER HOLES.

- REMOVE PROTECTIVE BLUE FILM.

- **GLOVES SHOULD BE WORN WHEN HANDLING ROOF METAL. EDGES ARE SHARP.**

SLIDE RIDGE CAP INTO PLACE ENSURING THAT BOTH ENDS ARE EQUAL DISTANCES FROM THE EDGES OF ROOF PANELS.

1116 (x12)
SELF TAPPING SCREW

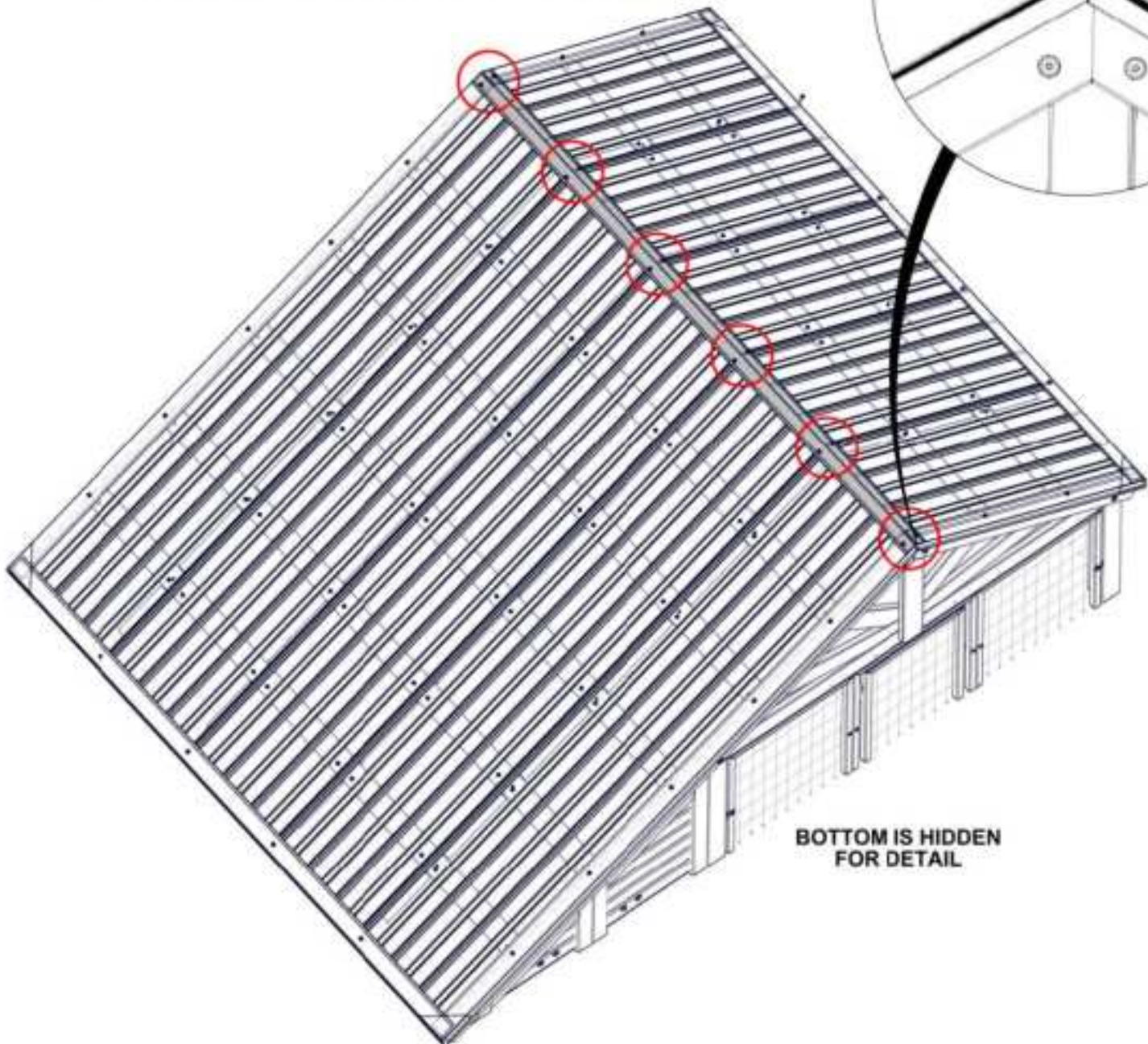
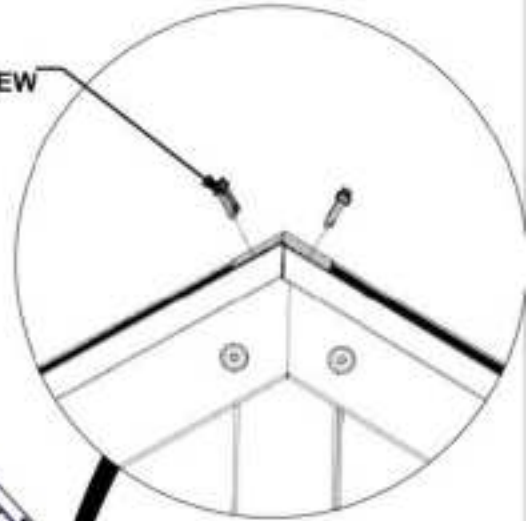

BOTTOM IS HIDDEN
FOR DETAIL

STEP 62 - DOOR LATCH ASSEMBLY

QTY	PART NUMBER	DESCRIPTION
4	H101076	SCREW POH 8-32 x 1 1/4 BLK
4	H100804	T-NUT 8/32 BLK
8	H100797	SCREW PWH 8x1 BLK

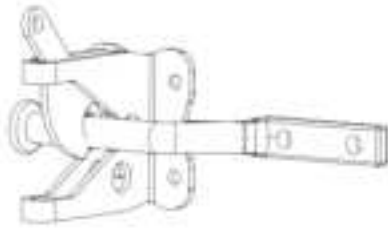

A100264 DOOR LATCH
(x2)

- INSERT T-NUTS FIRST
- USE PILOT HOLES TO ALIGN SCREWS

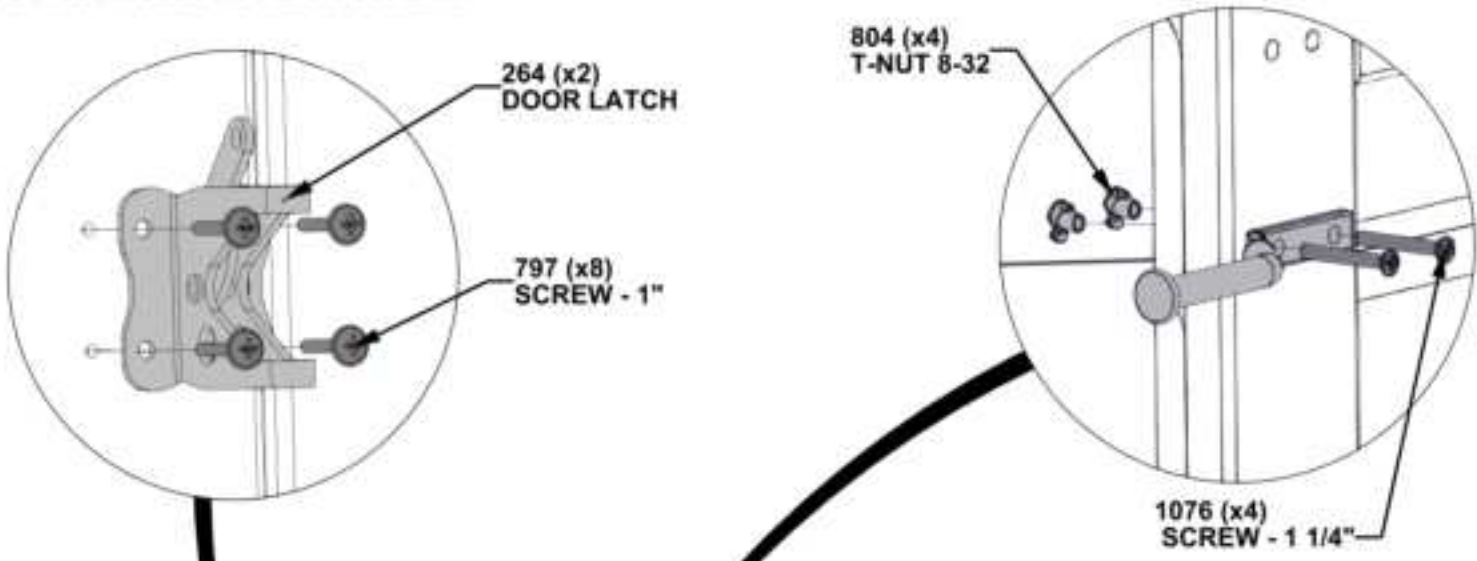

TOP IS HIDDEN FOR DETAIL.

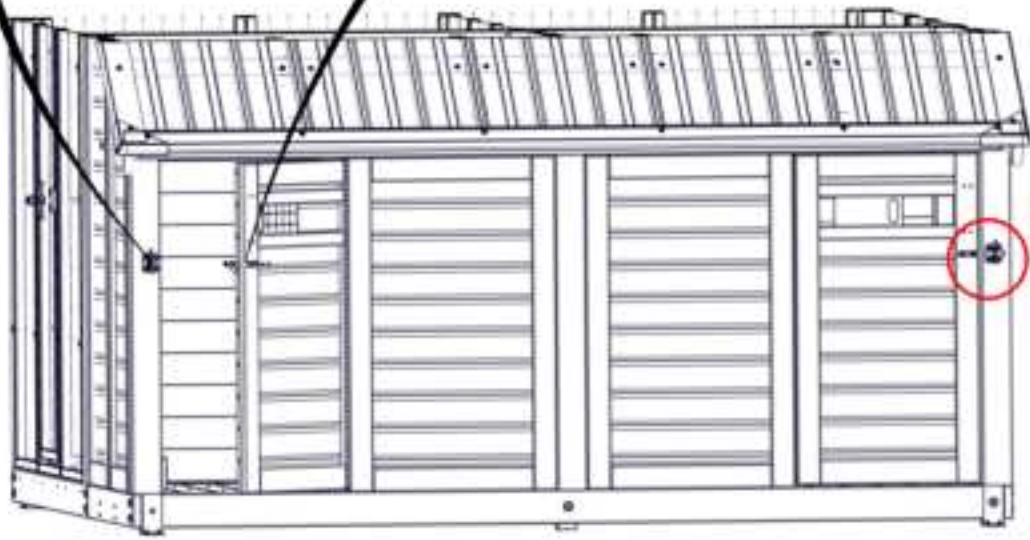

STEP 63 - DOOR HANDLE ASSEMBLY

QTY	PART NUMBER	DESCRIPTION
8	H100806	SCREW POH-MS 8/32x1 1/8" BLK
8	H100804	T-NUT 8/32 BLK

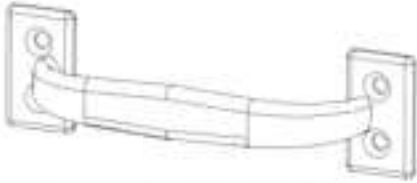

A4M00559 PULL HANDLE
(x2)

- INSERT T-NUTS FIRST

- ALIGN PULL HANDLES WITH HOLES IN DOORS

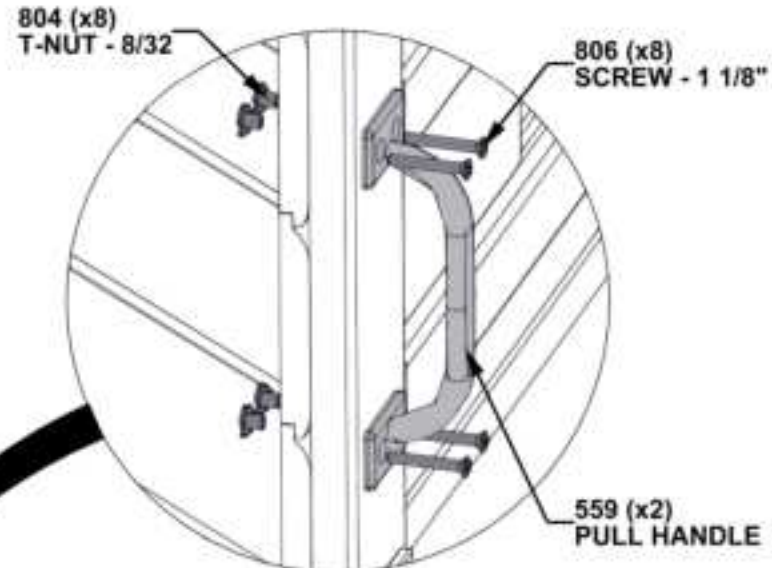

TOP IS HIDDEN FOR DETAIL

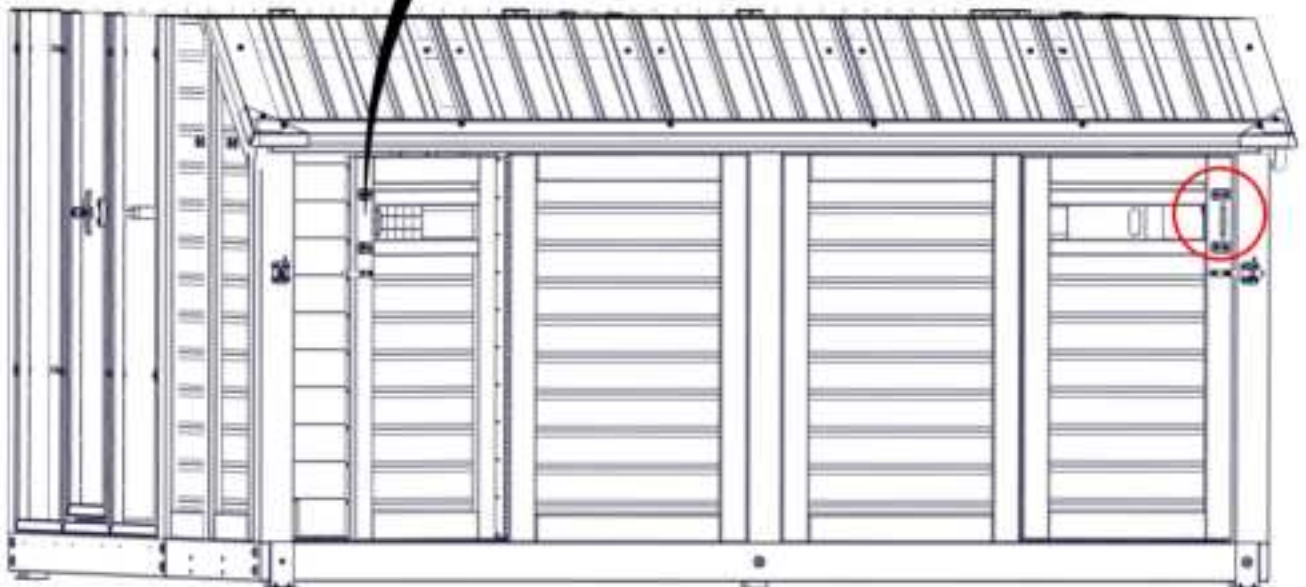

STEP 64 - DOOR LOCK ASSEMBLY

QTY	PART NUMBER	DESCRIPTION
4	H 100385	SCREW PFH 8x1" BLK
8	H 100387	SCREW PFH 8x1 1/4" BLK

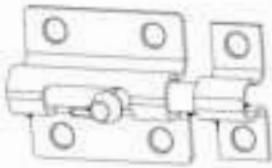

A100266 DEADBOLT
(x2)

- IT IS RECCOMENDED THAT AN 1/8" [3mm] DRILL BIT IS USED TO CREATE STARTER HOLES.
- ALL THE ENDS OF ALL THE METAL PLATES MUST BE ALIGNED

266 (x2)
DEADBOLT

385 (x4)
SCREW - 1"

387 (x8)
SCREW - 1 1/4"

TOP IS HIDDEN FOR DETAIL

1 1/4" [32 mm]

1 1/4" [32 mm]

7 7/8" [201 mm]

7 7/8" [201 mm]

STEP 65 - ANIMAL ENCLOSURE ASSY

QTY	PART NUMBER	DESCRIPTION
4	H100392	SCREW PWH 8x3/4 BLK



A4M02158 : BYD ID TAG PATIO
(x1)

- IT IS RECCOMENDED THAT
AN 1/8" [3mm] DRILL BIT IS
USED TO CREATE STARTER HOLES.

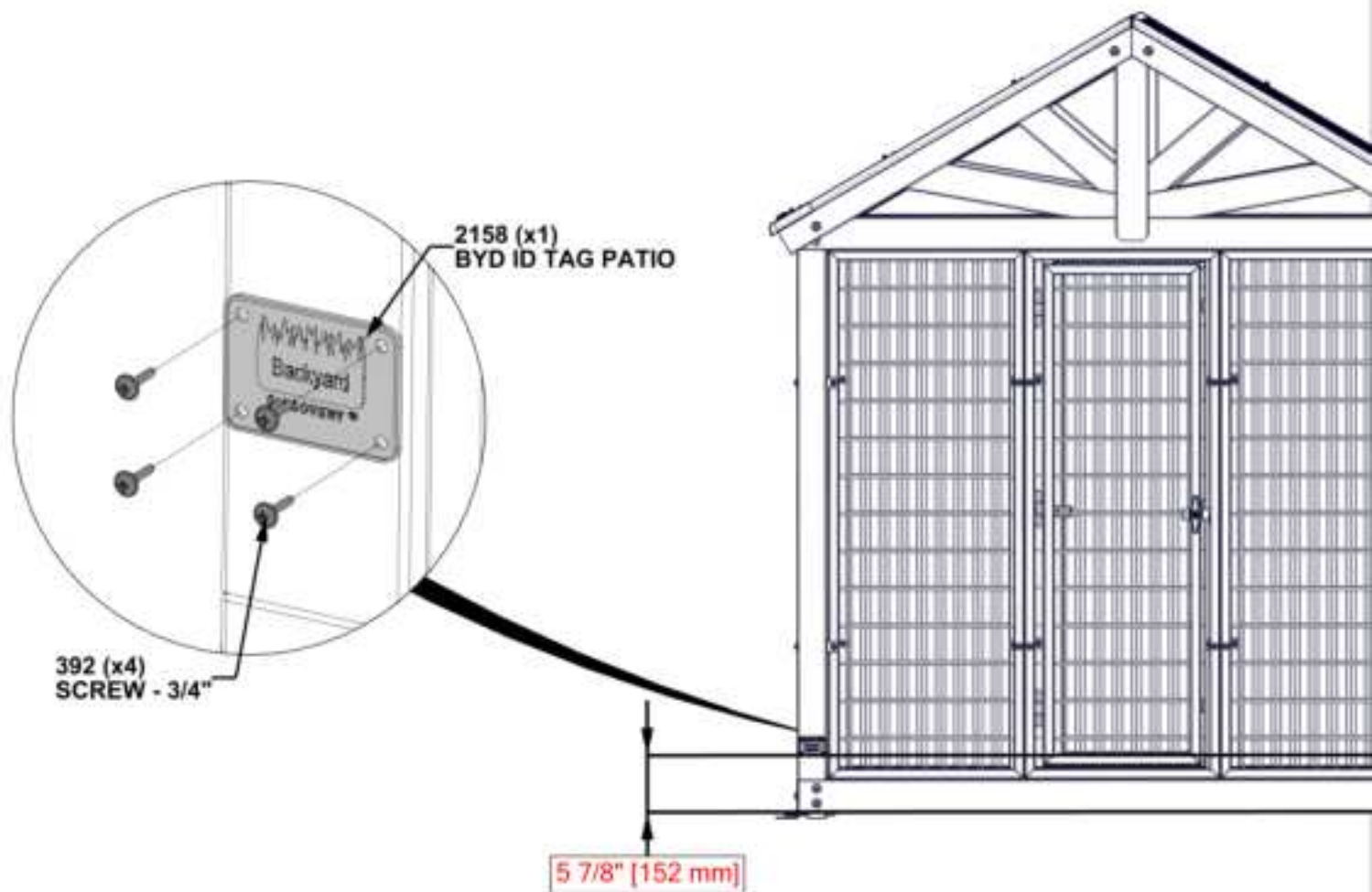

STEP 66 - ANIMAL ENCLOSURE ASSY



A4M02971 CARABINER
(x2)

- CARABINERS HAVE BEEN PROVIDED FOR OPTIMAL USE OF SECURING DOOR LATCHES.

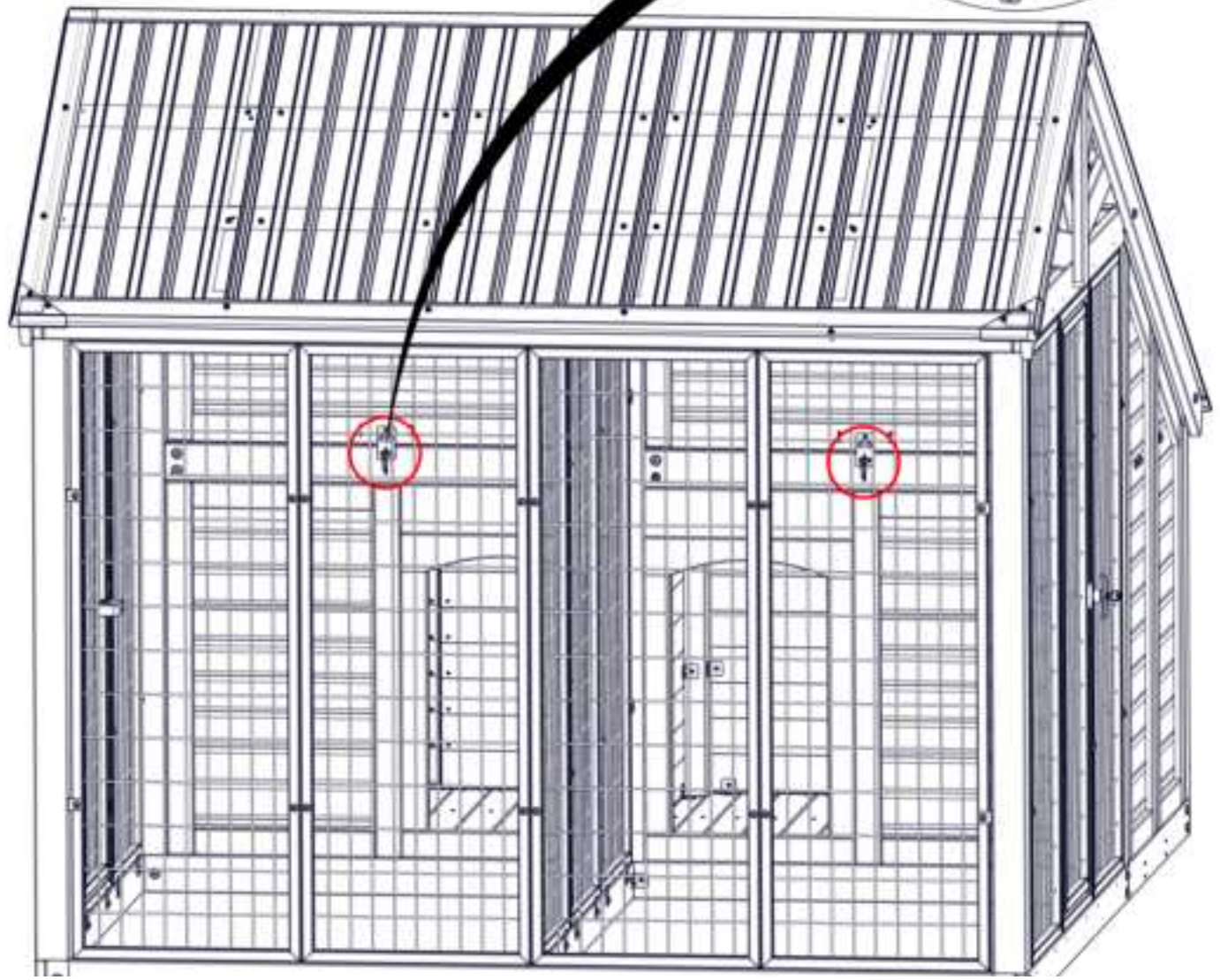
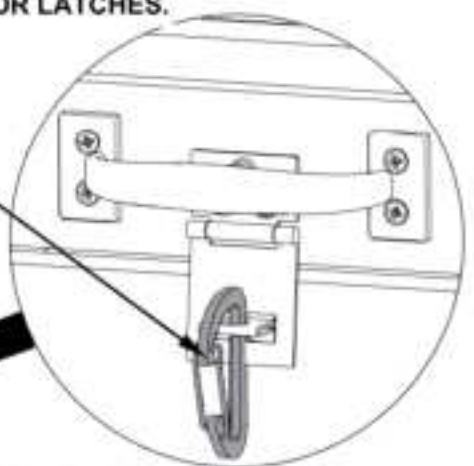

STEP 67A - ANIMAL ENCLOSURE ASSY



A4M03459 SWING HOOK LATCH
(x1)

- PREDRILL 1/8" [3mm] PILOT HOLES FOR THE ATTACHMENT OF SWING HOOK LATCH
- ATTACH EYELET SCREW & SAVE HOOK FOR NEXT STEP

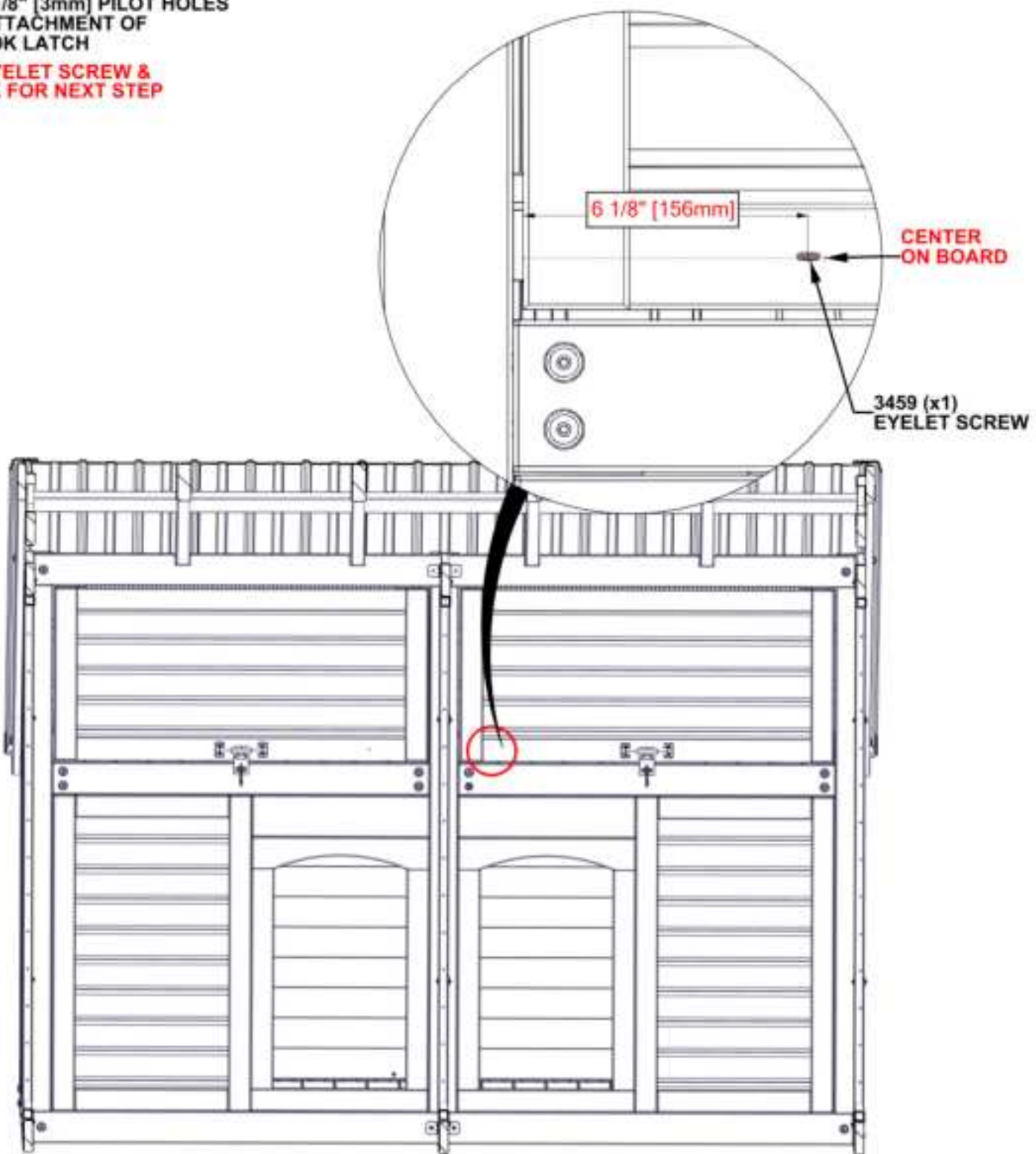

STEP 67B - ANIMAL ENCLOSURE ASSY



A4M03459 SWING HOOK LATCH
(x1)

- USE HOOK FROM PREVIOUS STEP

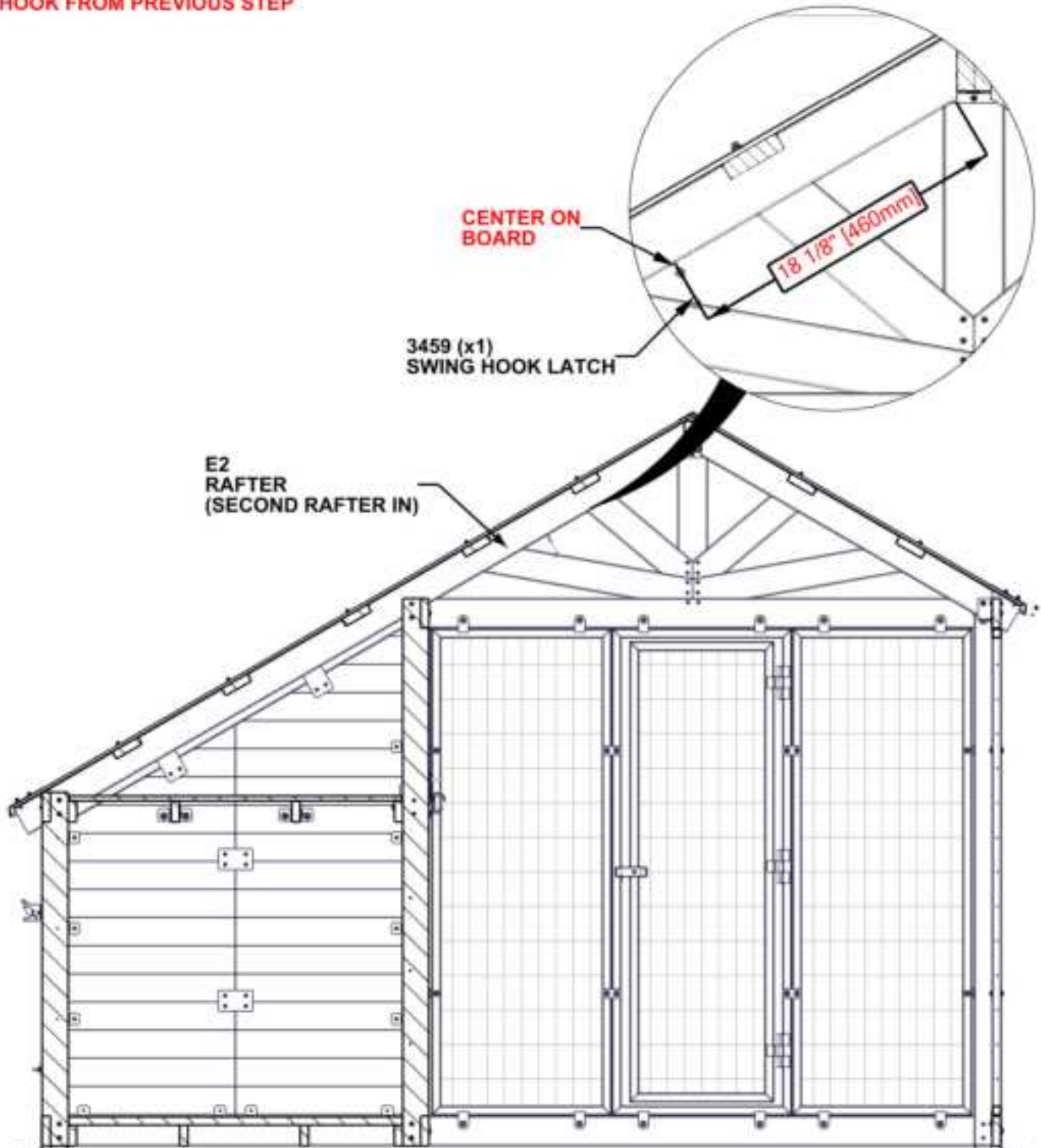

STEP 67C - ANIMAL ENCLOSURE ASSY

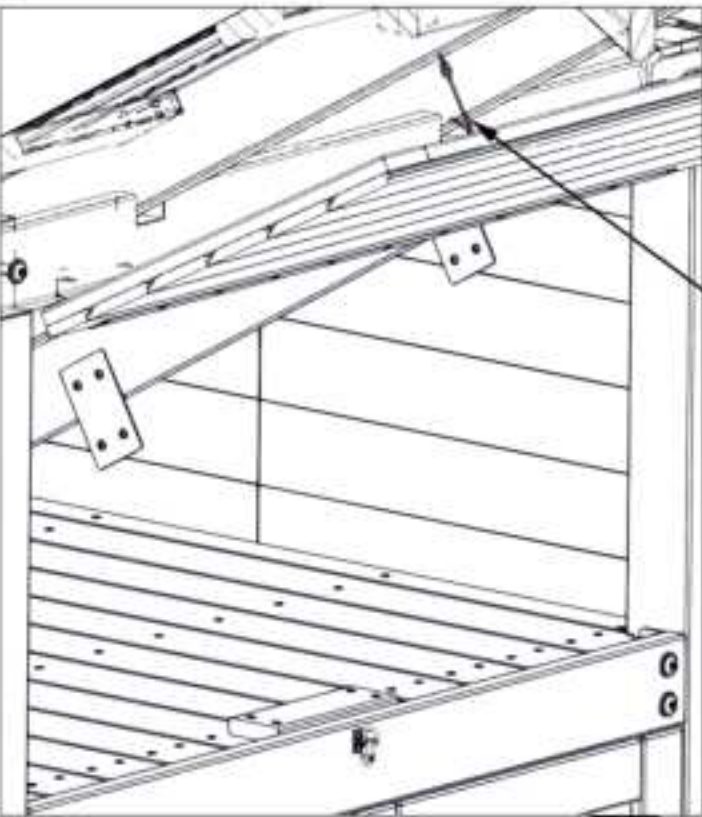

AFTER INSTALLING THE SWING HOOK LATCH, YOU CAN SECURE THE STORAGE DOOR IN THE OPEN POSITION AS SHOWN. PLEASE NOTE THAT THE MANUFACTURER RECOMMENDS KEEPING THE STORAGE DOOR CLOSED WHEN NOT IN USE.



FRONT & LEFT IS HIDDEN FOR DETAIL

STEP 68A - ANIMAL ENCLOSURE ASSY



A4M03459 SWING HOOK LATCH
(x1)

- PREDRILL 1/8" [3mm] PILOT HOLES
FOR THE ATTACHMENT OF
SWING HOOK LATCH

- ATTACH EYELET SCREW &
SAVE HOOK FOR NEXT STEP

CENTER ON
BOARD

6 1/8" [156mm]

3459 (x1)
EYELET SCREW

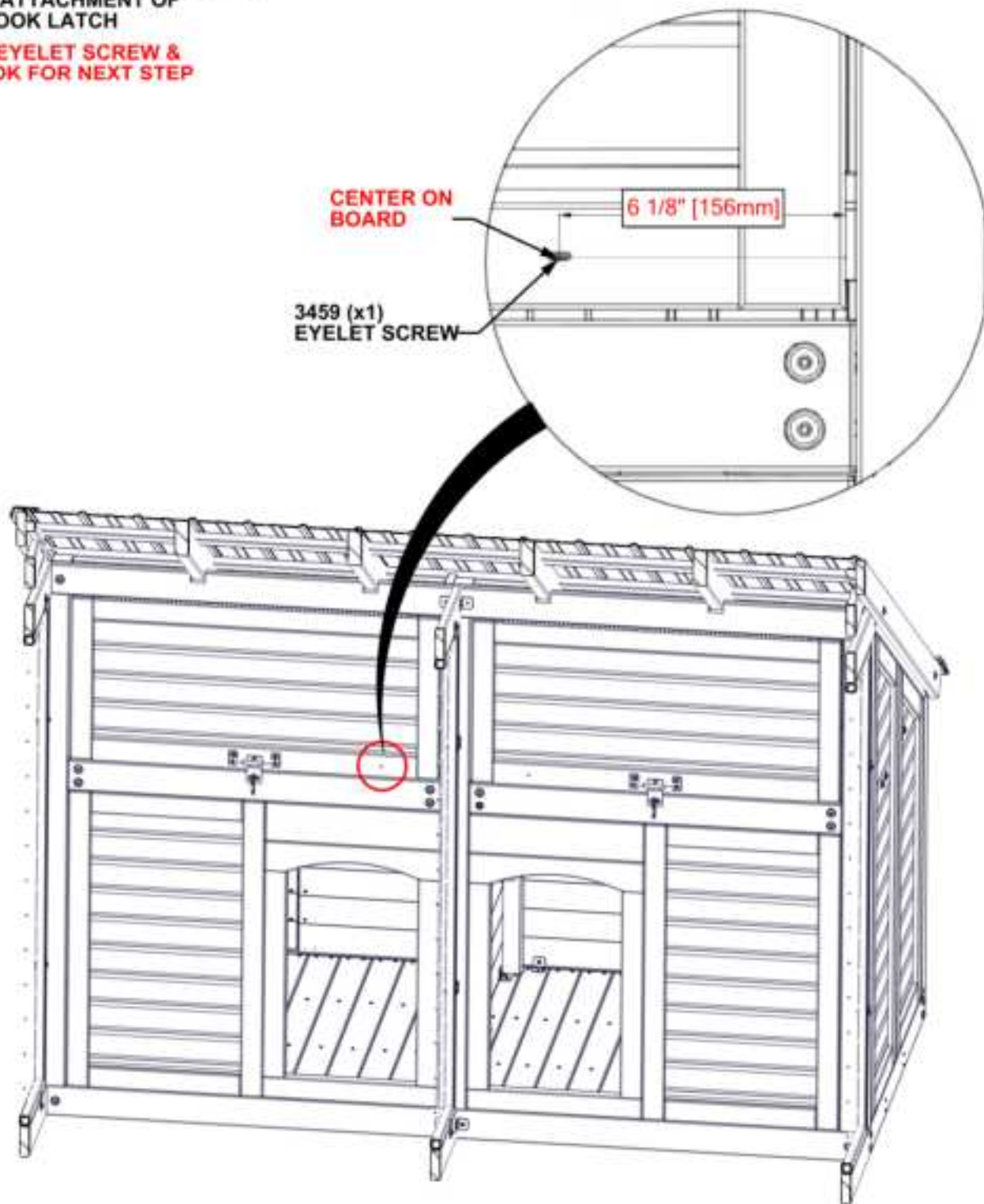

STEP 68B - ANIMAL ENCLOSURE ASSY



A4M03459 SWING HOOK LATCH
(x1)

- USE HOOK FROM PREVIOUS STEP

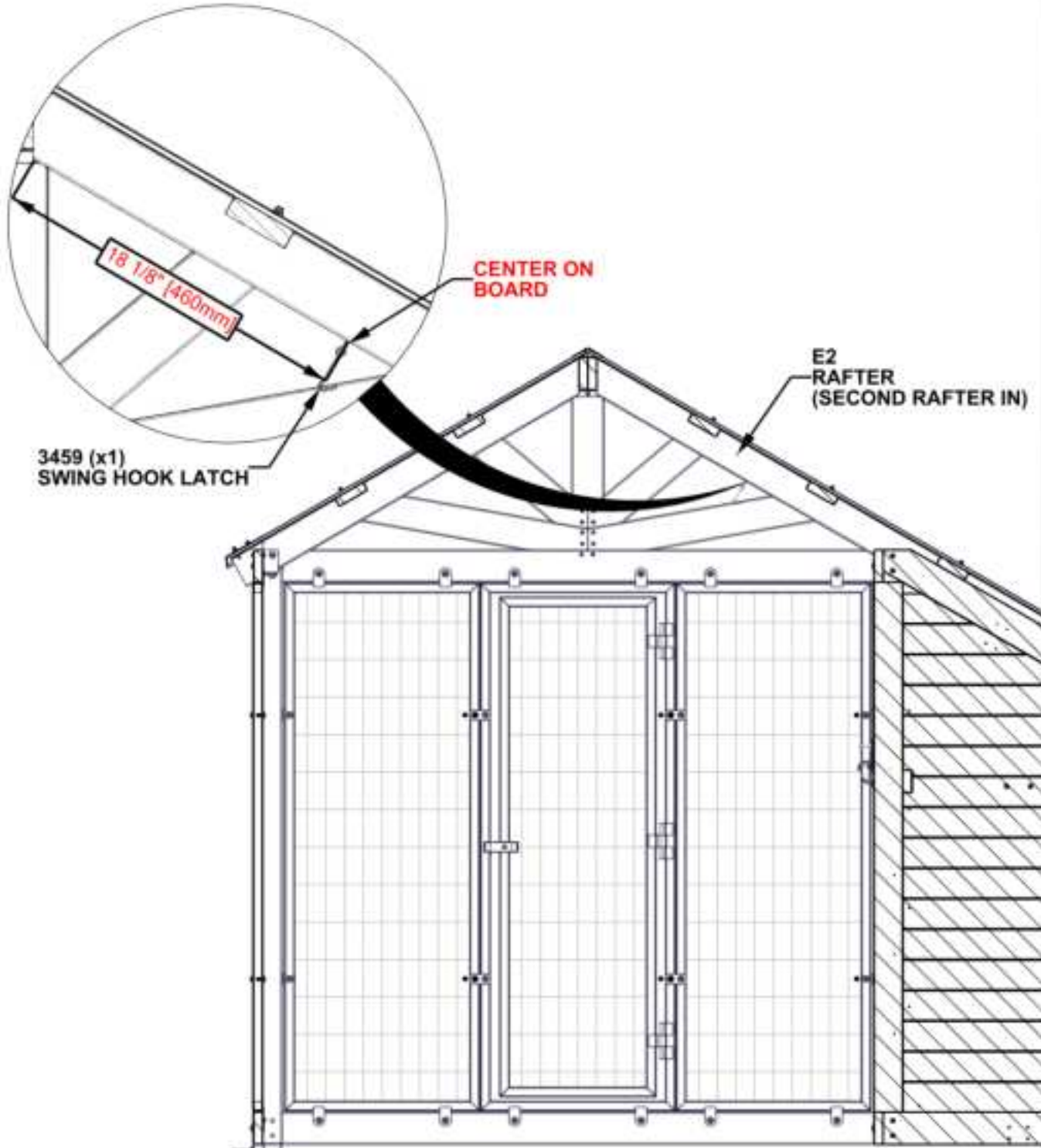

STEP 68C - ANIMAL ENCLOSURE ASSY

AFTER INSTALLING THE SWING HOOK LATCH, YOU CAN SECURE THE STORAGE DOOR IN THE OPEN POSITION AS SHOWN. PLEASE NOTE THAT THE MANUFACTURER RECOMMENDS KEEPING THE STORAGE DOOR CLOSED WHEN NOT IN USE.

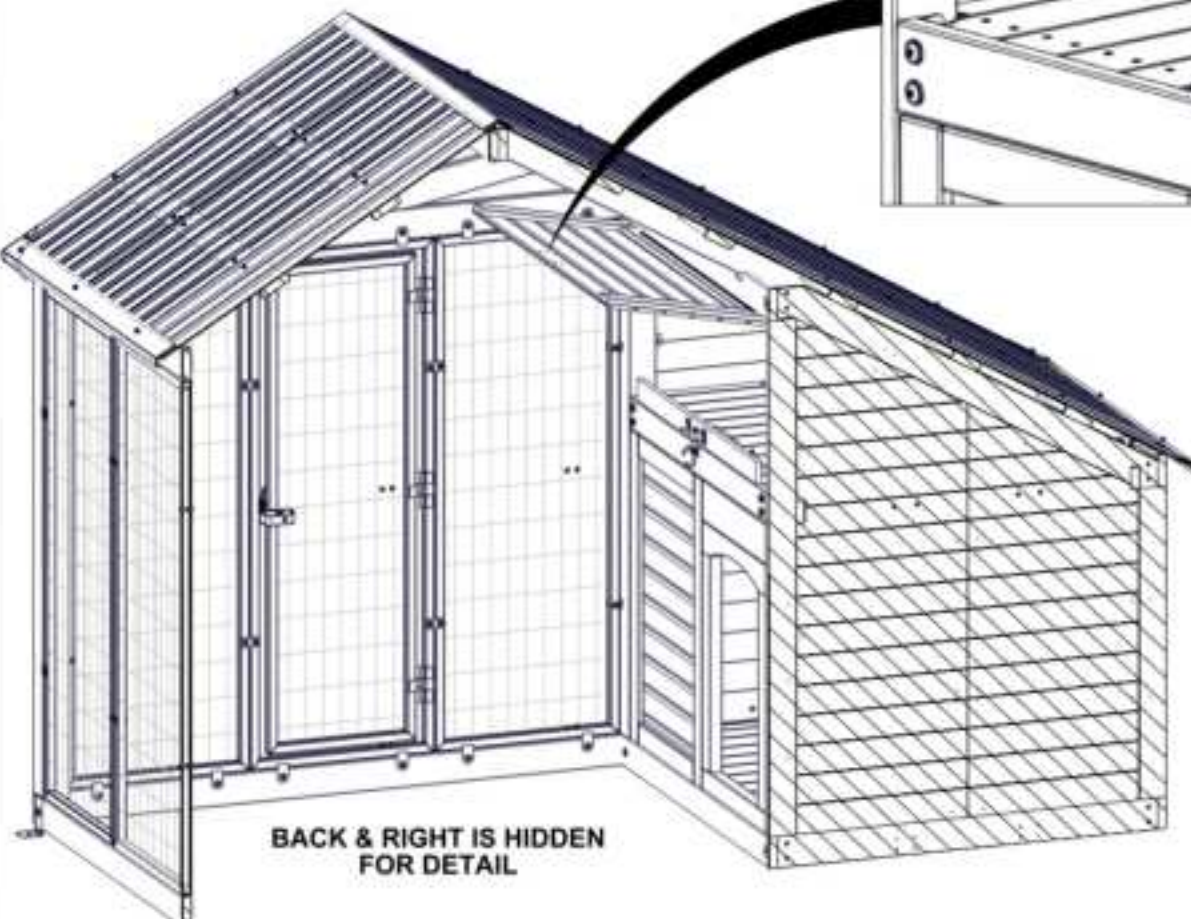
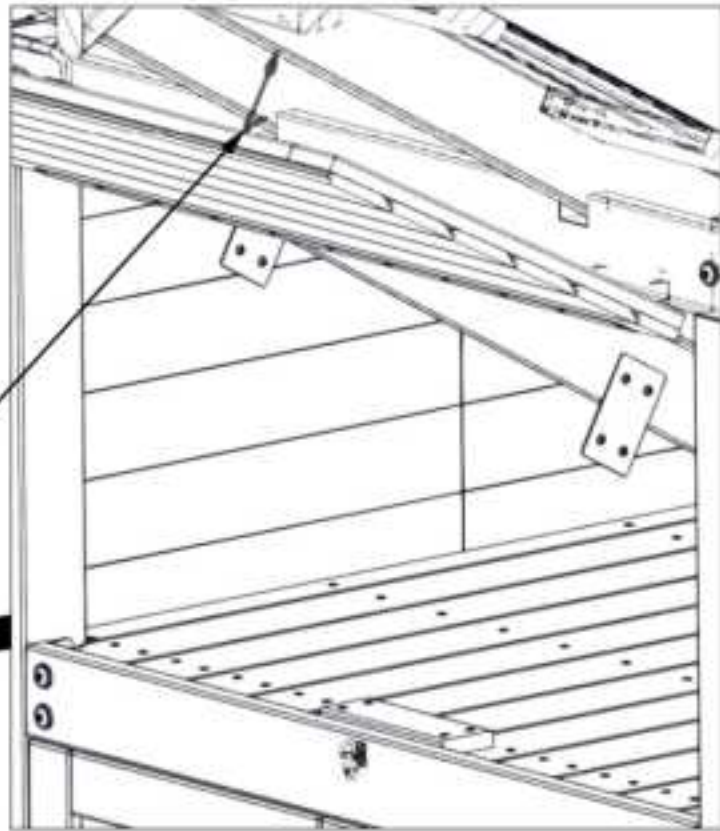

BACK & RIGHT IS HIDDEN FOR DETAIL

STEP 69A - ANCHORING IN GROUND



A4M02091 GROUND STAKE
(x4)

IF ENCLOSURE IS ON A CONCRETE SURFACE, SEE STEP 69B FOR ANCHORING STRUCTURE

2091 (x4)
GROUND STAKE

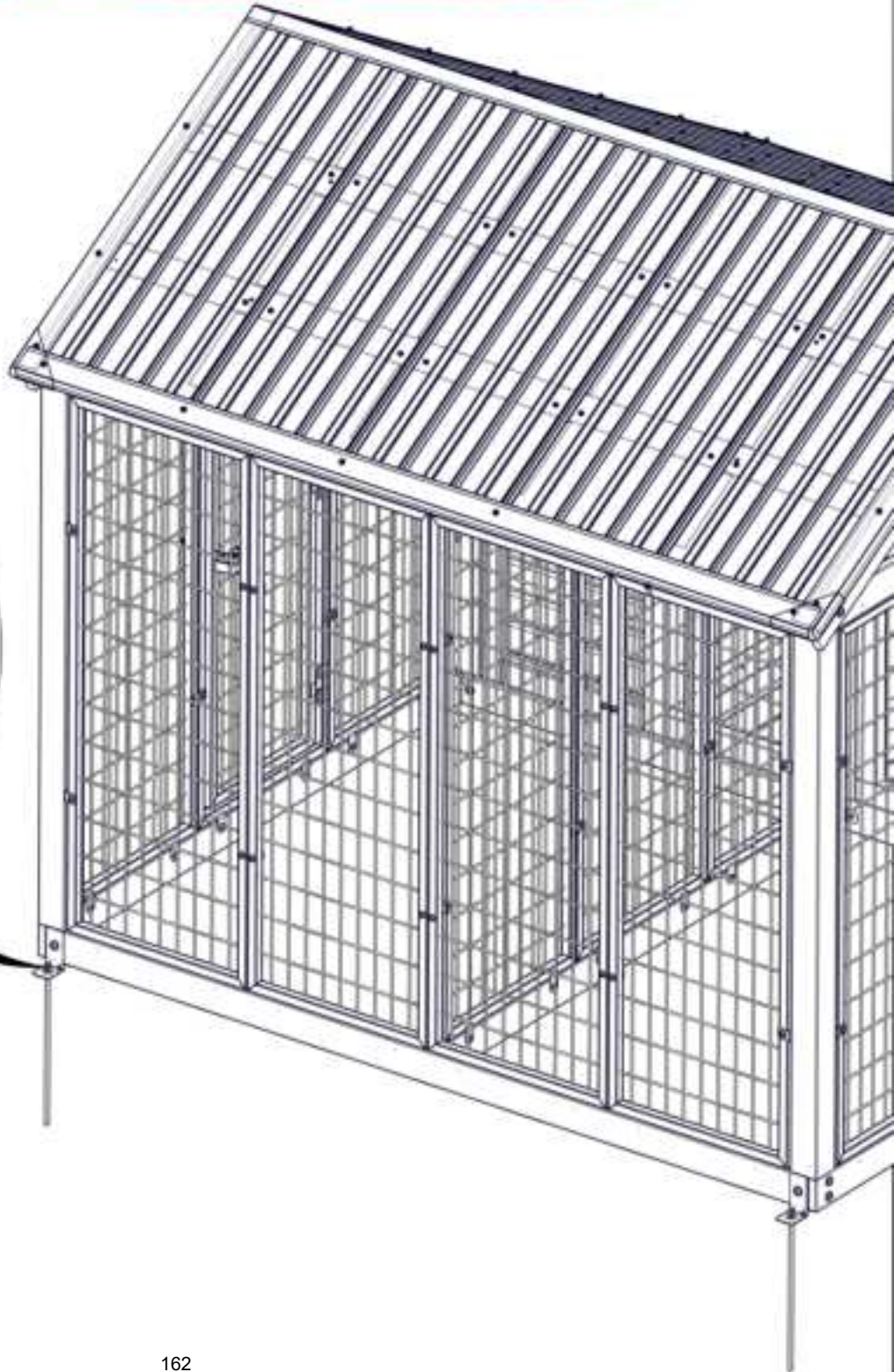

STEP 69B - ANCHORING IN GROUND

QTY	PART NUMBER	DESCRIPTION
4	H101165	CONCRETE ANCHOR 3/8x3" BLK

IF ENCLOSURE IS NOT ON A CONCRETE SURFACE, SEE STEP 69A FOR ANCHORING STRUCTURE
IT IS RECOMMENDED TO ANCHOR ONTO A CONCRETE PAD OR CONCRETE POSTS

1165 (x4)
CONCRETE ANCHOR-3"

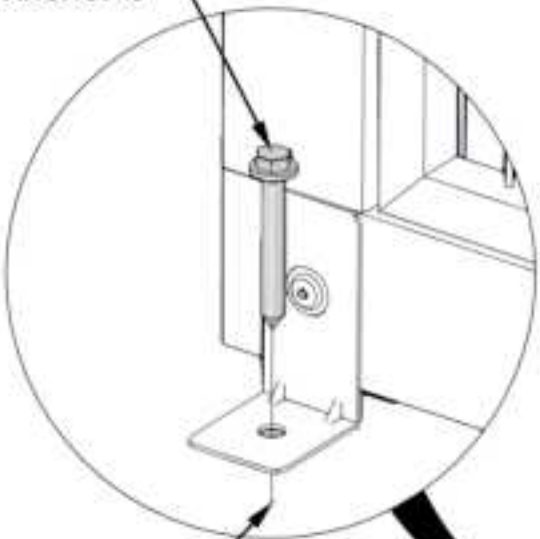

PRE-DRILL FOR CONCRETE ANCHORS USING A 5/16" [8mm] CONCRETE DRILL BIT

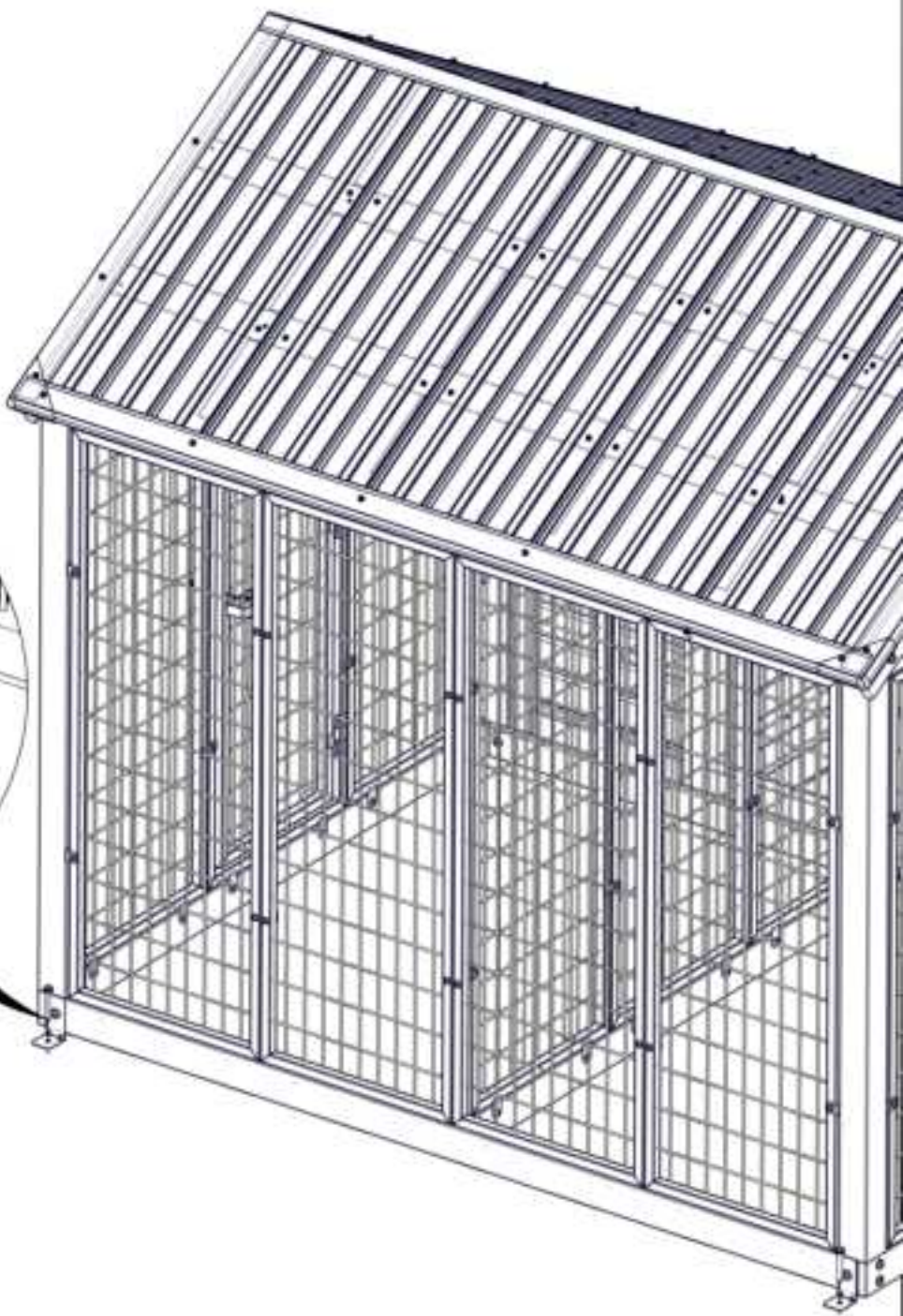

STEP 70 - MIDDLE MESH PANEL

QTY	PART NUMBER	DESCRIPTION
6	H100460	LAG SCREW WH 1/4x1 BLK

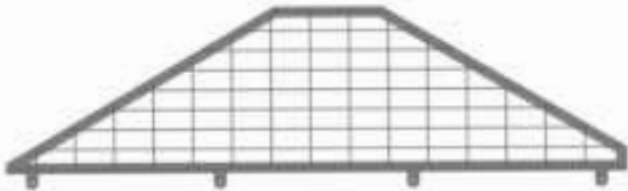

7061 MESH PANEL - A4M07061
(x1) 2 1/16"x18 1/8"x62 5/16" (53.0x459.9x1582.4)

- USING THE BRACKETS AS A GUIDE, PREDRILL 1/8" [3mm] PILOT HOLES FOR THE ATTACHMENT OF HARDWARE.
- USE PILOT HOLES TO ALIGN SCREWS.

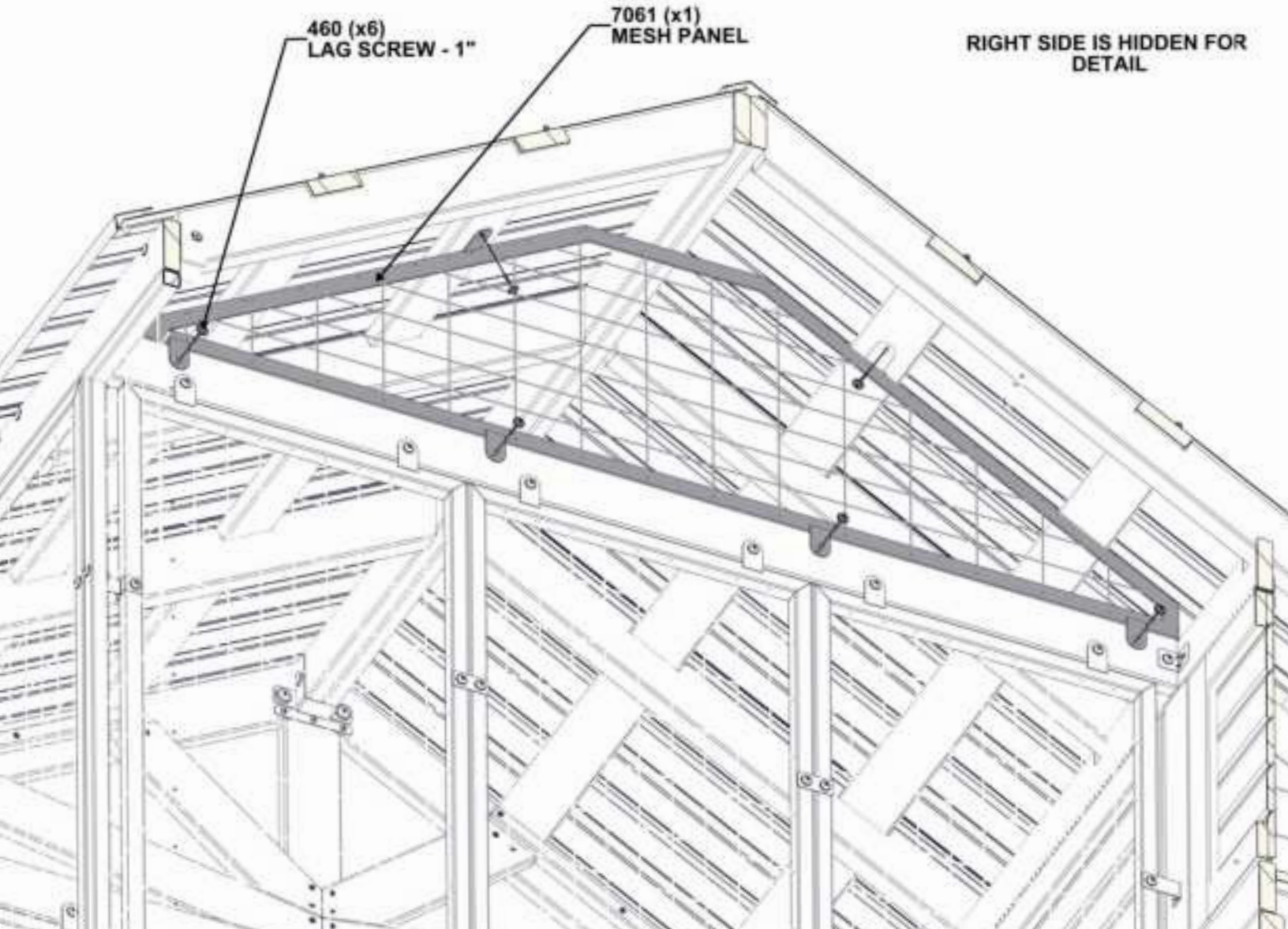

STEP 71 - ANIMAL ENCLOSURE ASSY



A4M02971 CARABINER
(x2)

- CARABINERS HAVE BEEN PROVIDED FOR OPTIMAL USE OF SECURING DOOR LATCHES.

