

# 2106536D CORDOVA 14X10 Container Loading Diagram

( 1 set=5 boxes 60 sets/40HQ, 20 pallets/ 40HQ, Gross Weight: 19600kg)

Top view

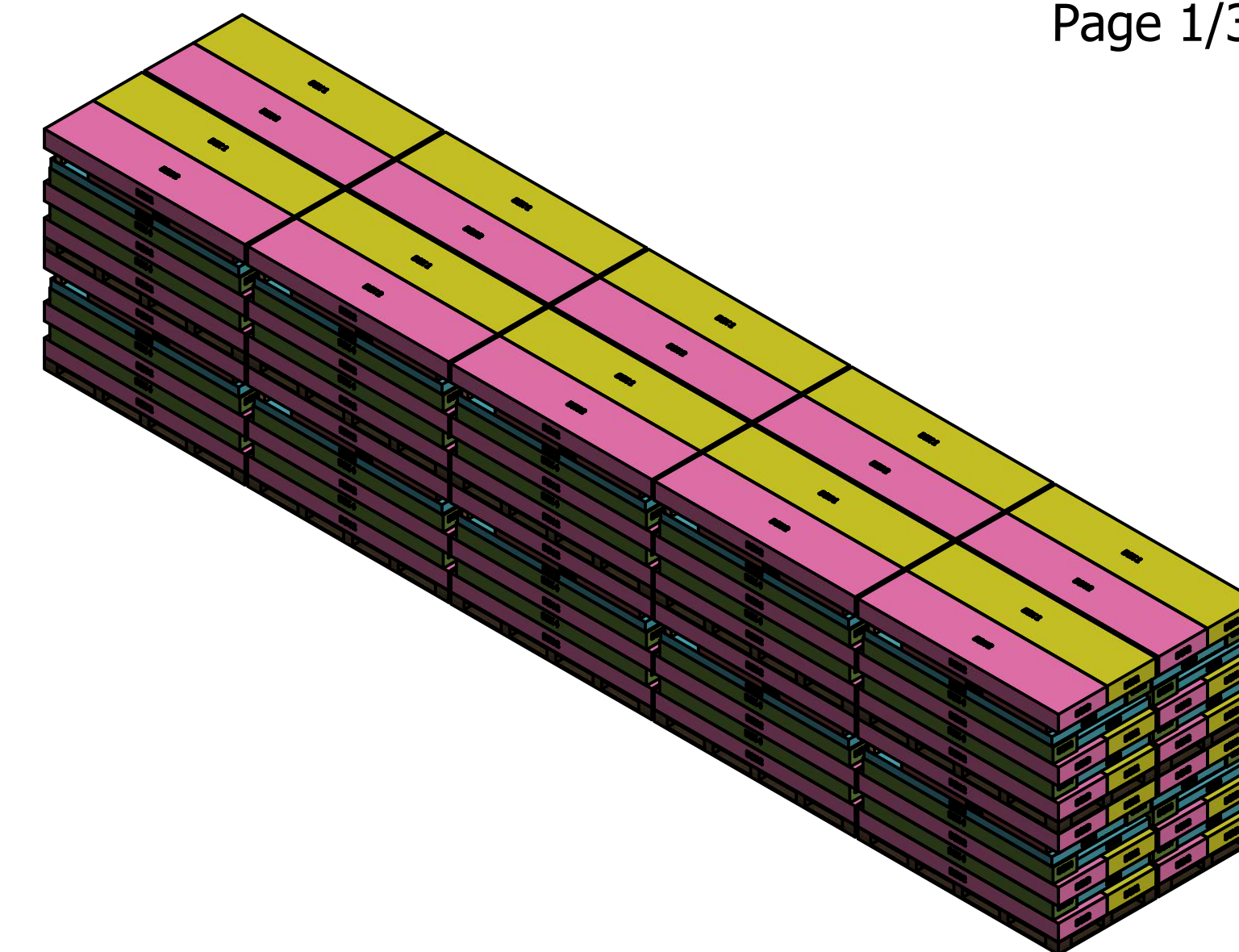
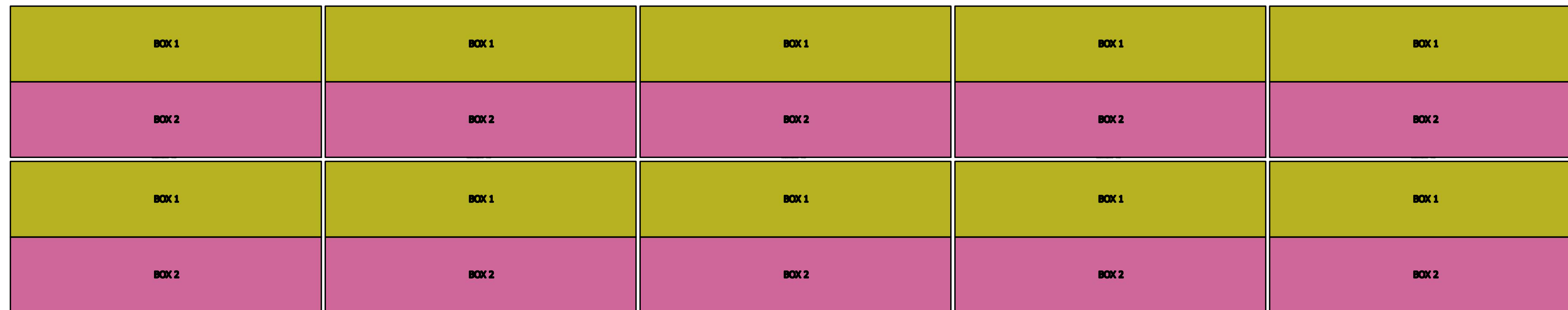

Side view

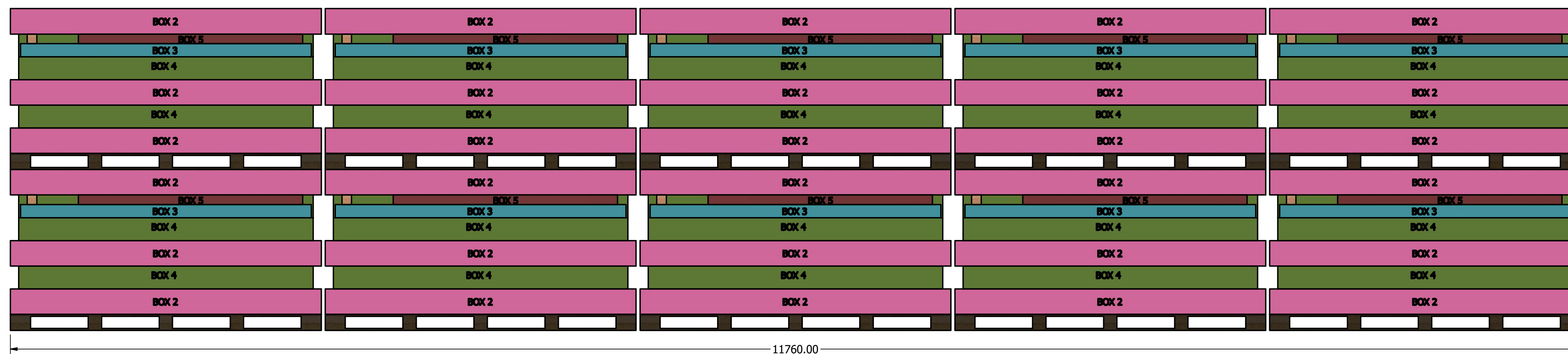

End view

Pallet A \* 20

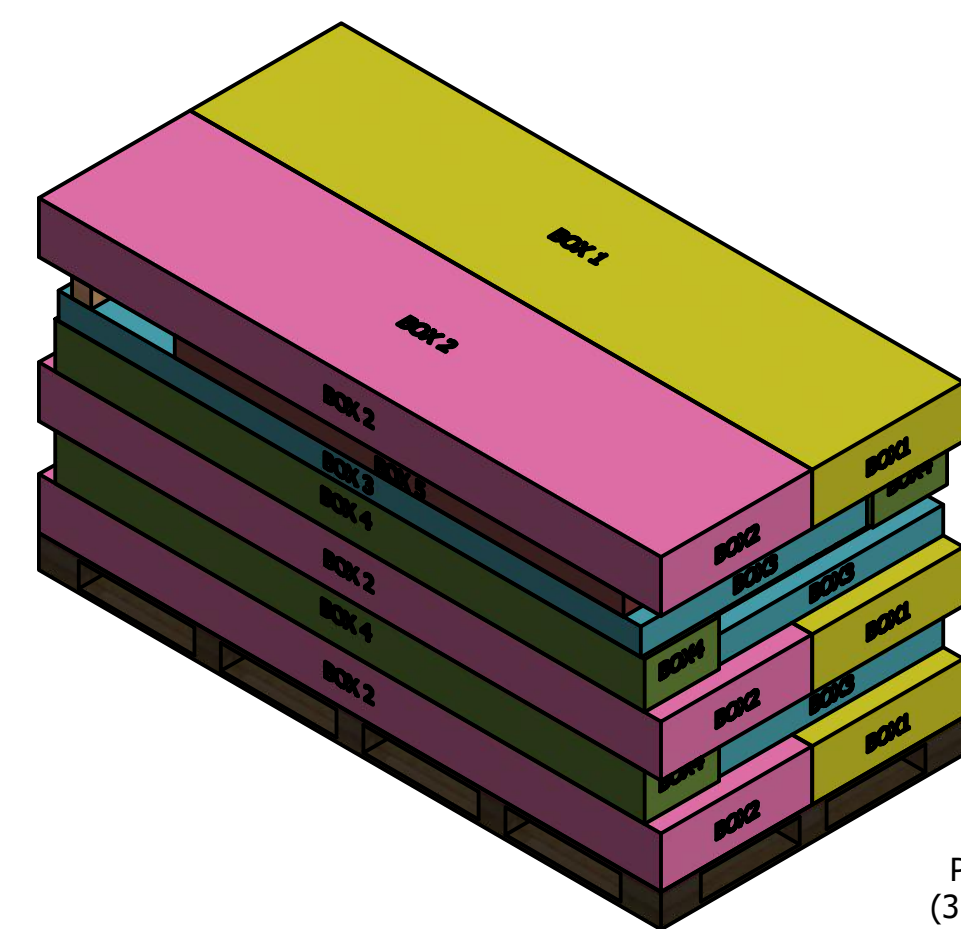
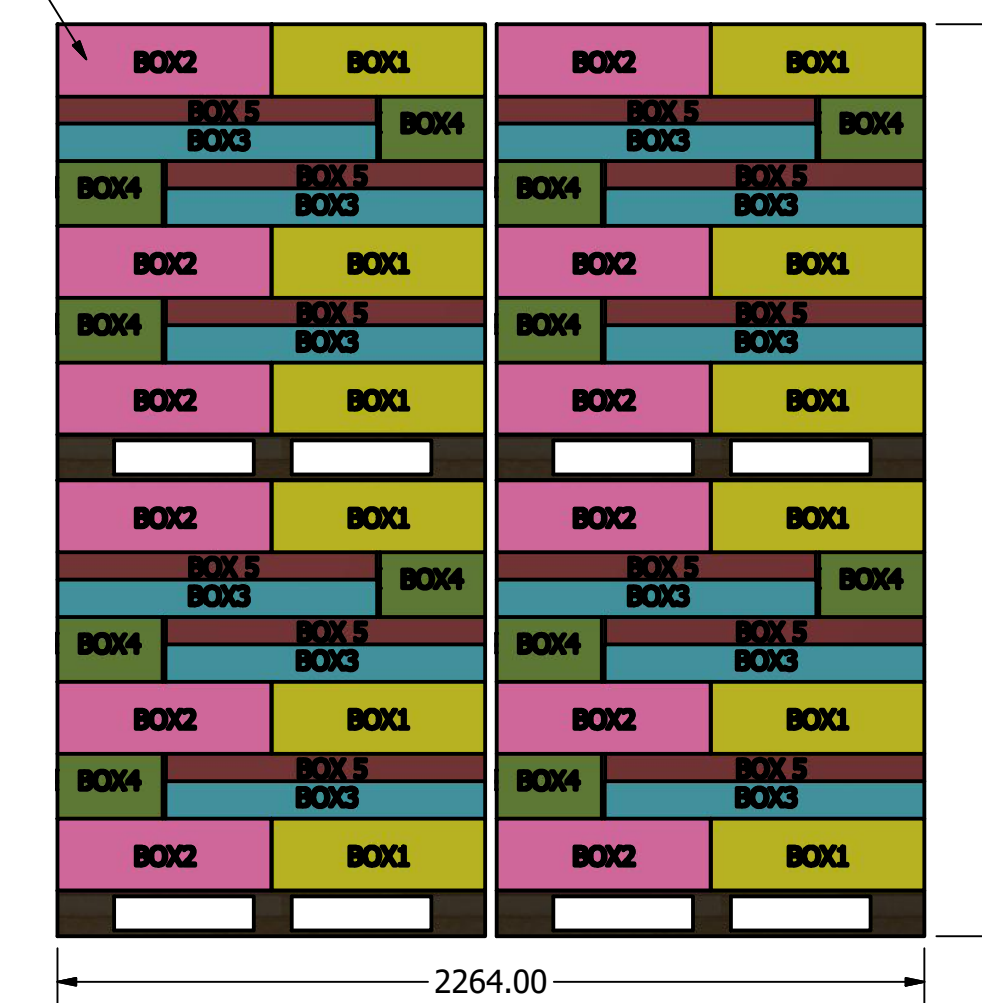

Pallet A \*20  
(3 sets/ Pallet)

|               |           |                 |                     |
|---------------|-----------|-----------------|---------------------|
| DRAWN<br>Rudy | 2019/8/19 |                 |                     |
| CHECKED       |           | TITLE           |                     |
| QA            |           |                 |                     |
| MFG           |           |                 |                     |
| APPROVED      |           |                 |                     |
|               |           | SIZE<br>D       | DWG NO<br>2006522   |
|               |           | SCALE<br>1 / 20 | REV<br>SHEET 1 OF 1 |

Pallet A ( 3 sets/pallet )

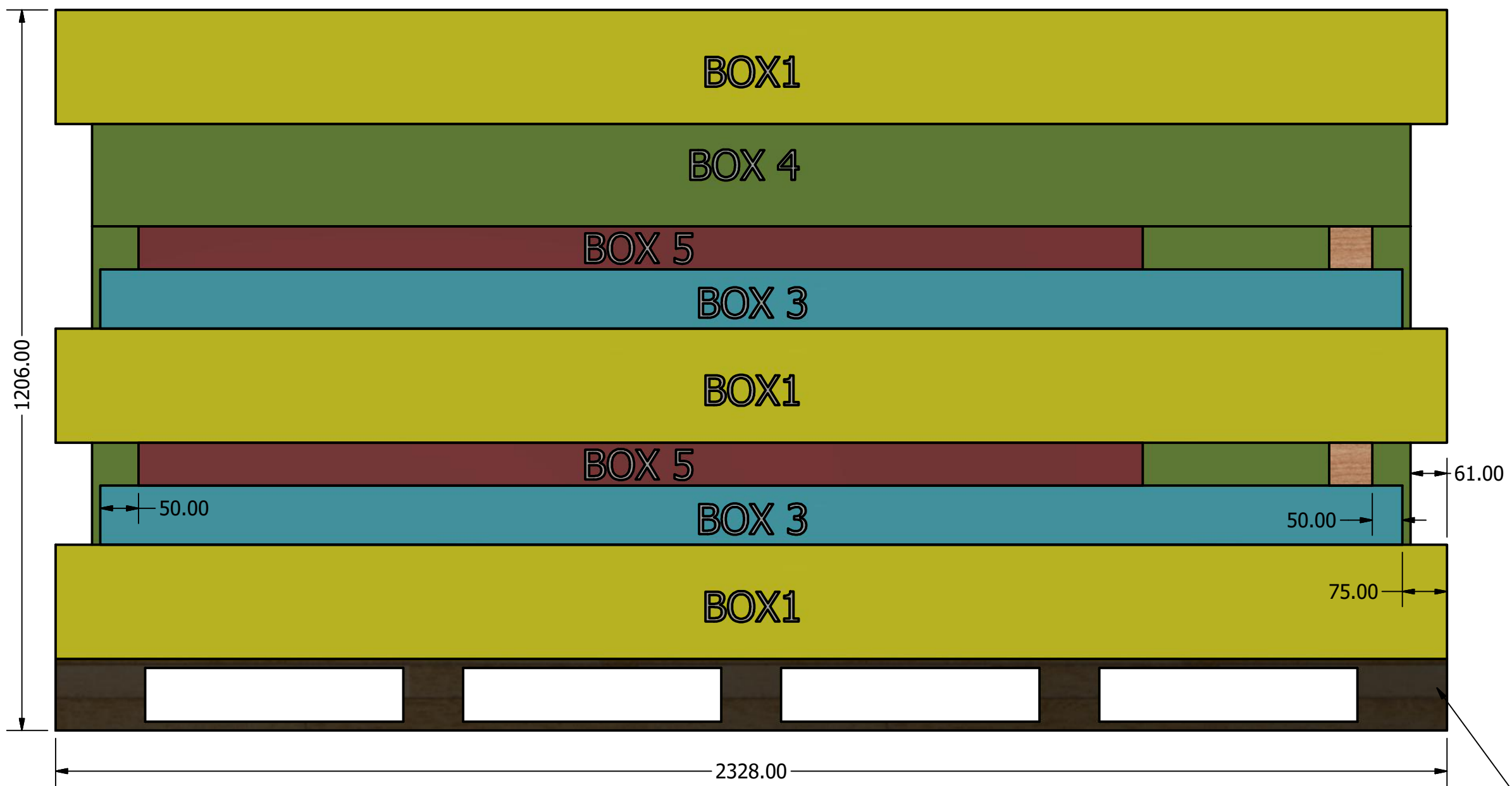
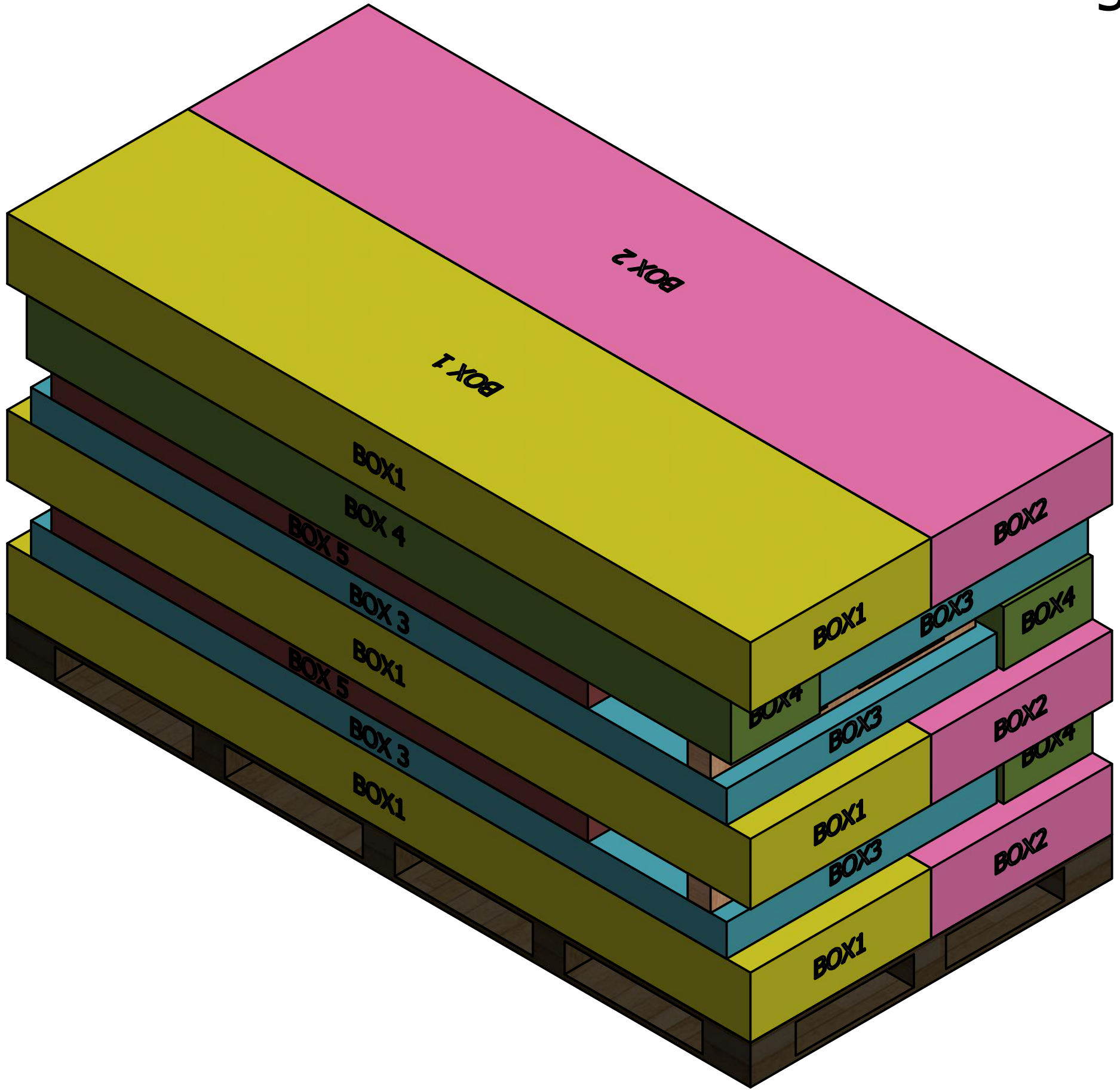

胶合板支撑块 Plywood block \* 3pcs  
830mm\*72mm\*72mm

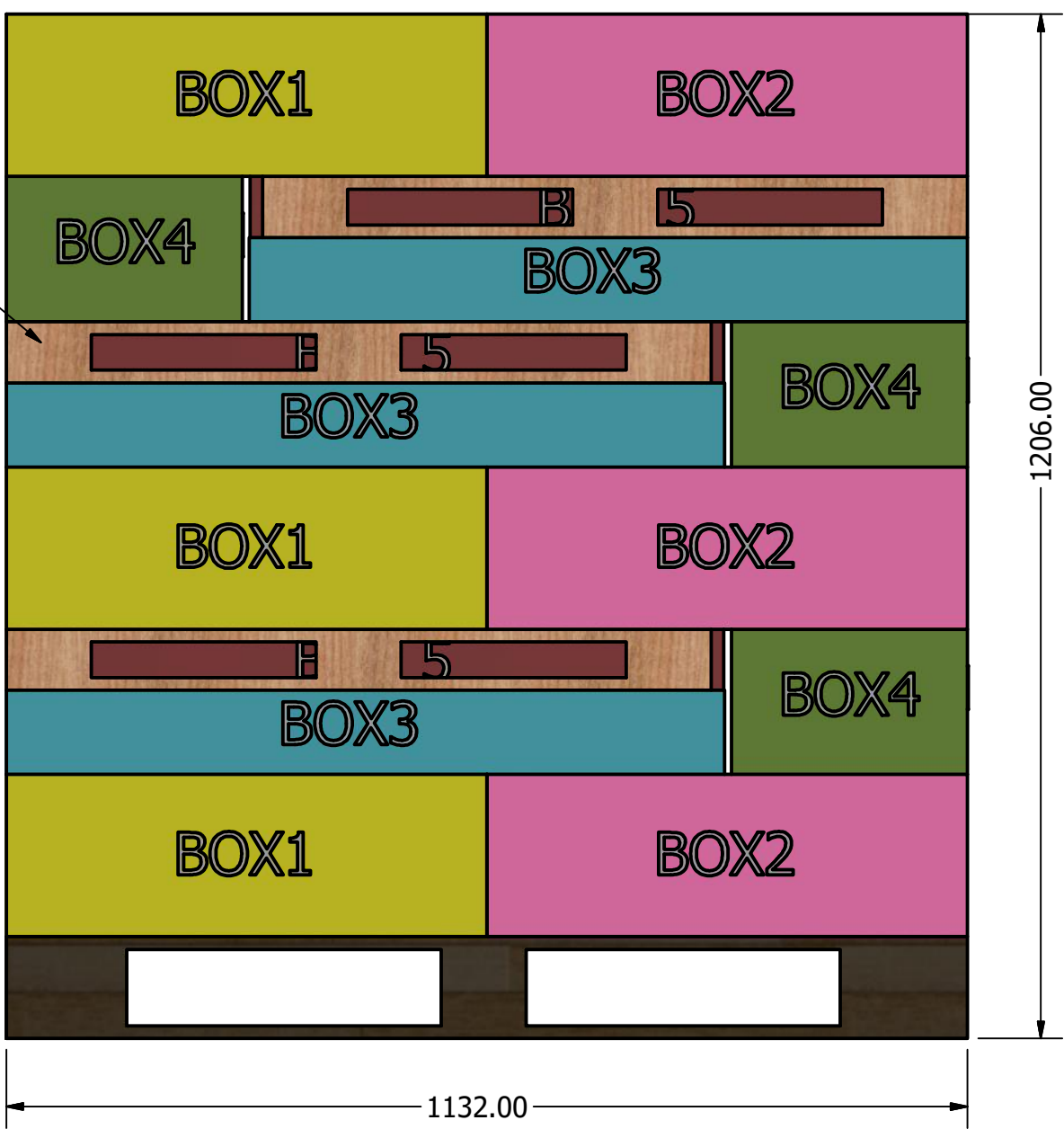

托盘料号 (Pallet part number) : PKG101011

|               |           |                 |                    |
|---------------|-----------|-----------------|--------------------|
| DRAWN<br>Rudy | 2019/8/19 |                 |                    |
| CHECKED       |           | TITLE           |                    |
| QA            |           |                 |                    |
| MFG           |           |                 |                    |
| APPROVED      |           |                 |                    |
|               |           | SIZE<br>D       | DWG NO<br>Pallet A |
|               |           | SCALE<br>1 : 10 | REV                |
|               |           | SHEET 1 OF 1    |                    |

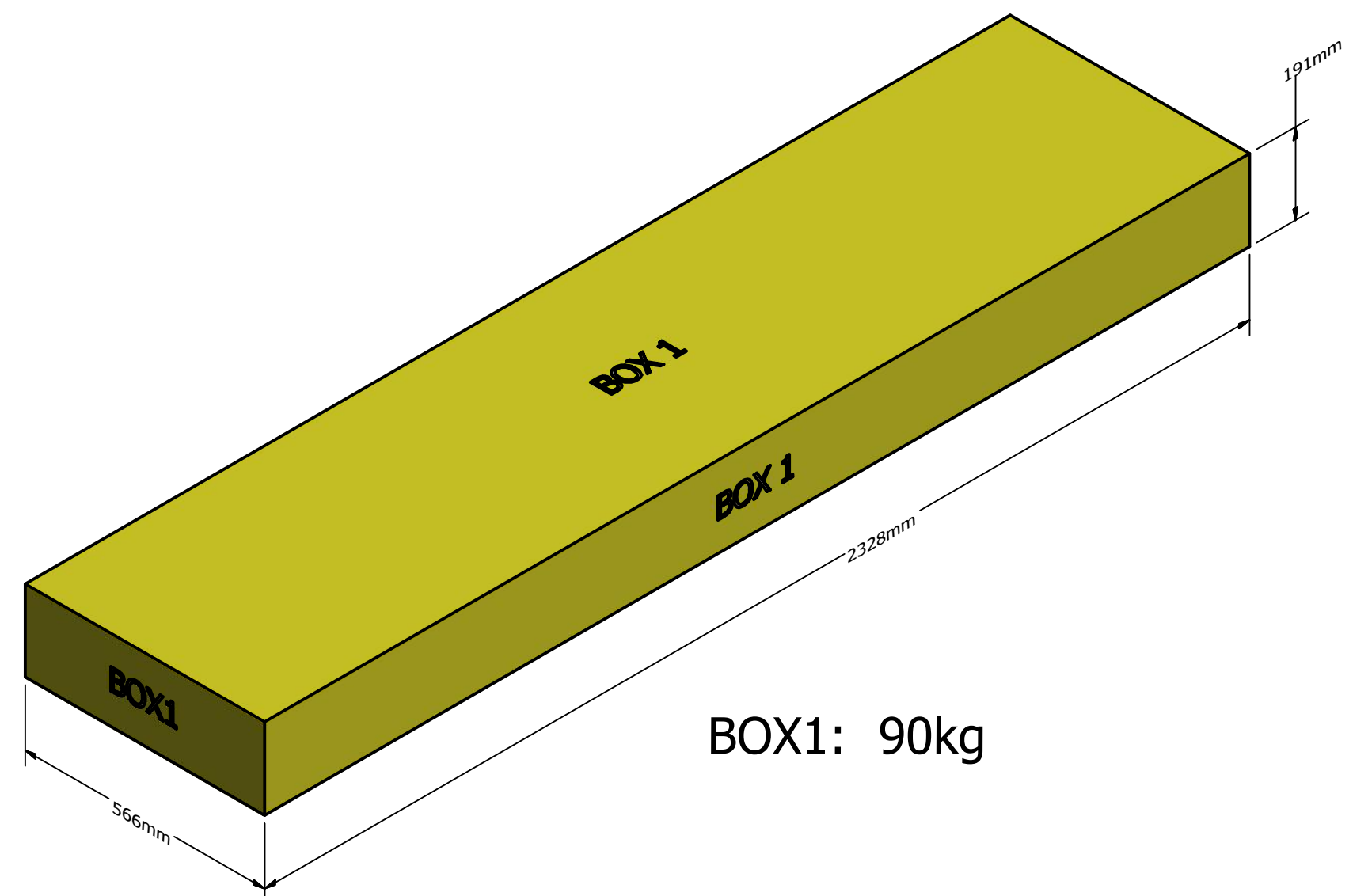

BOX1: 90kg

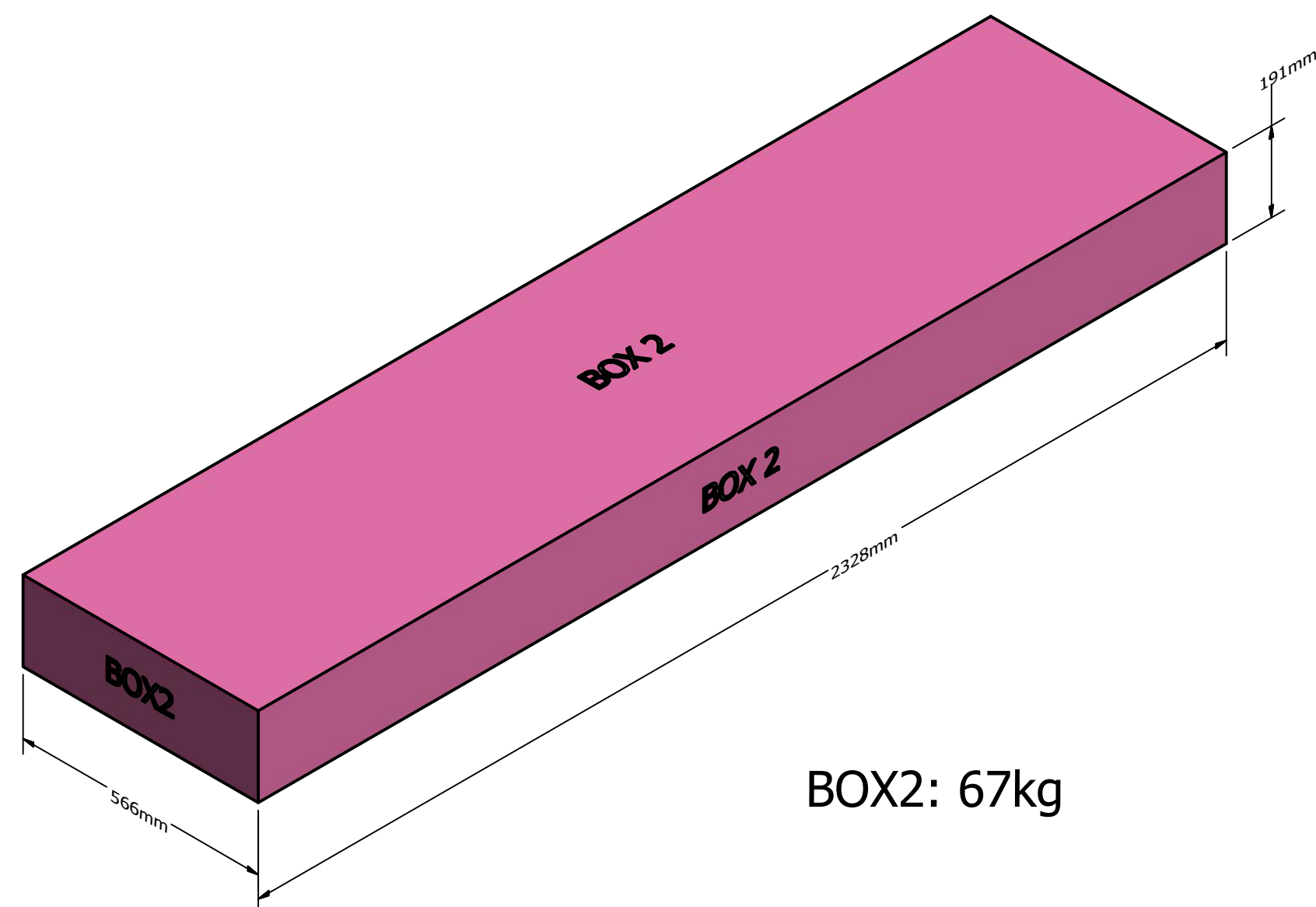

BOX2: 67kg

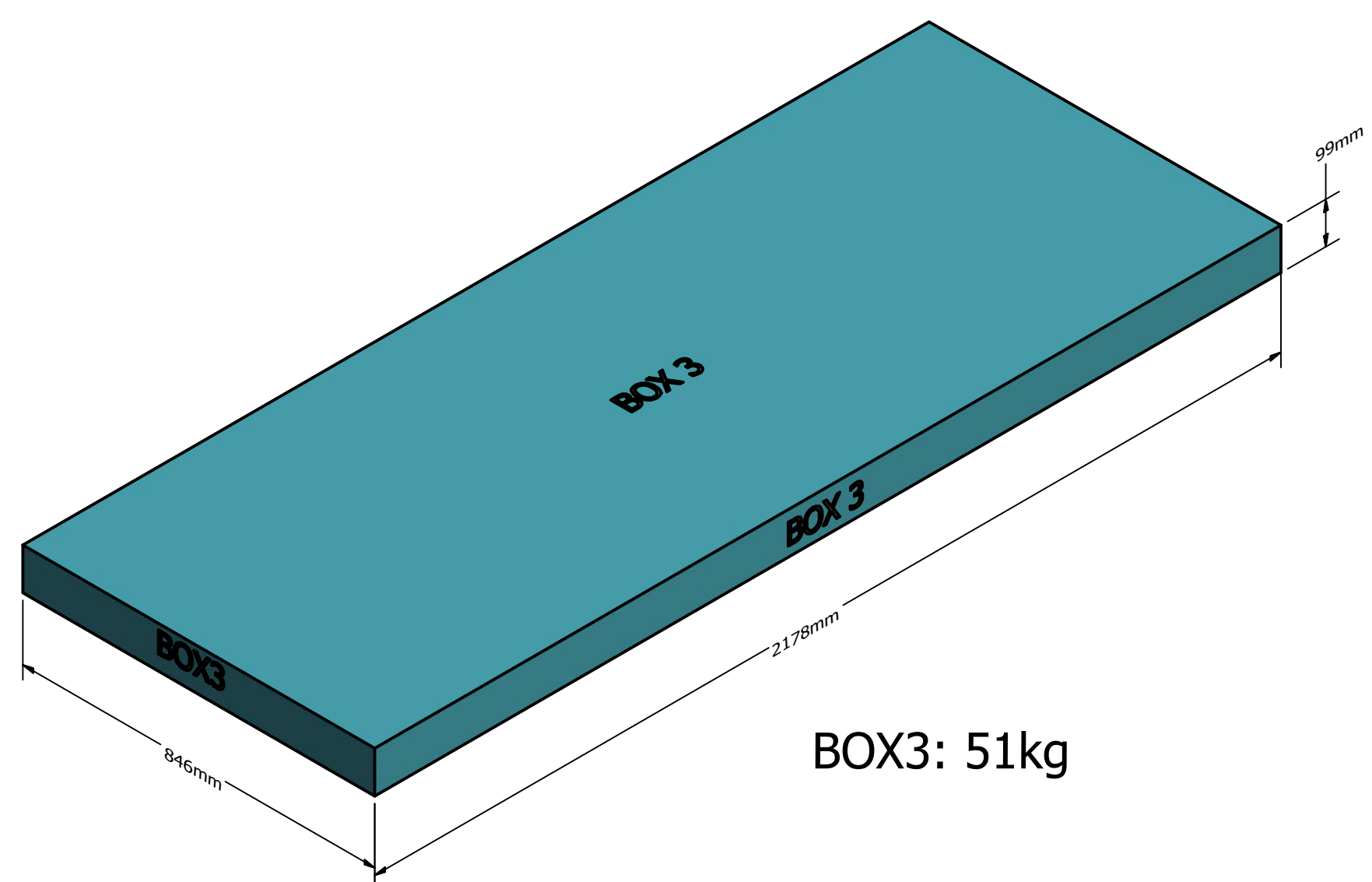

BOX3: 51kg

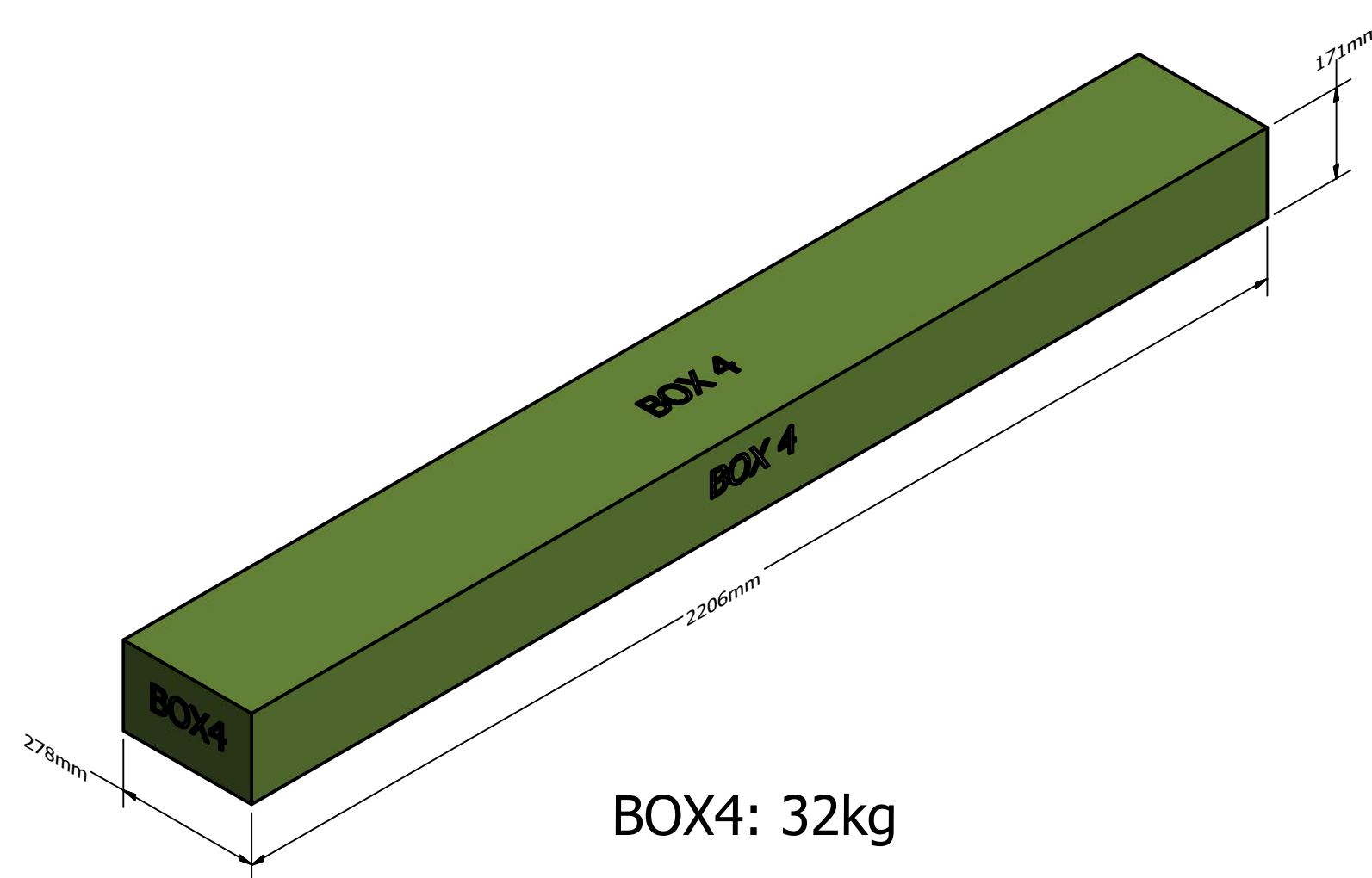

BOX4: 32kg

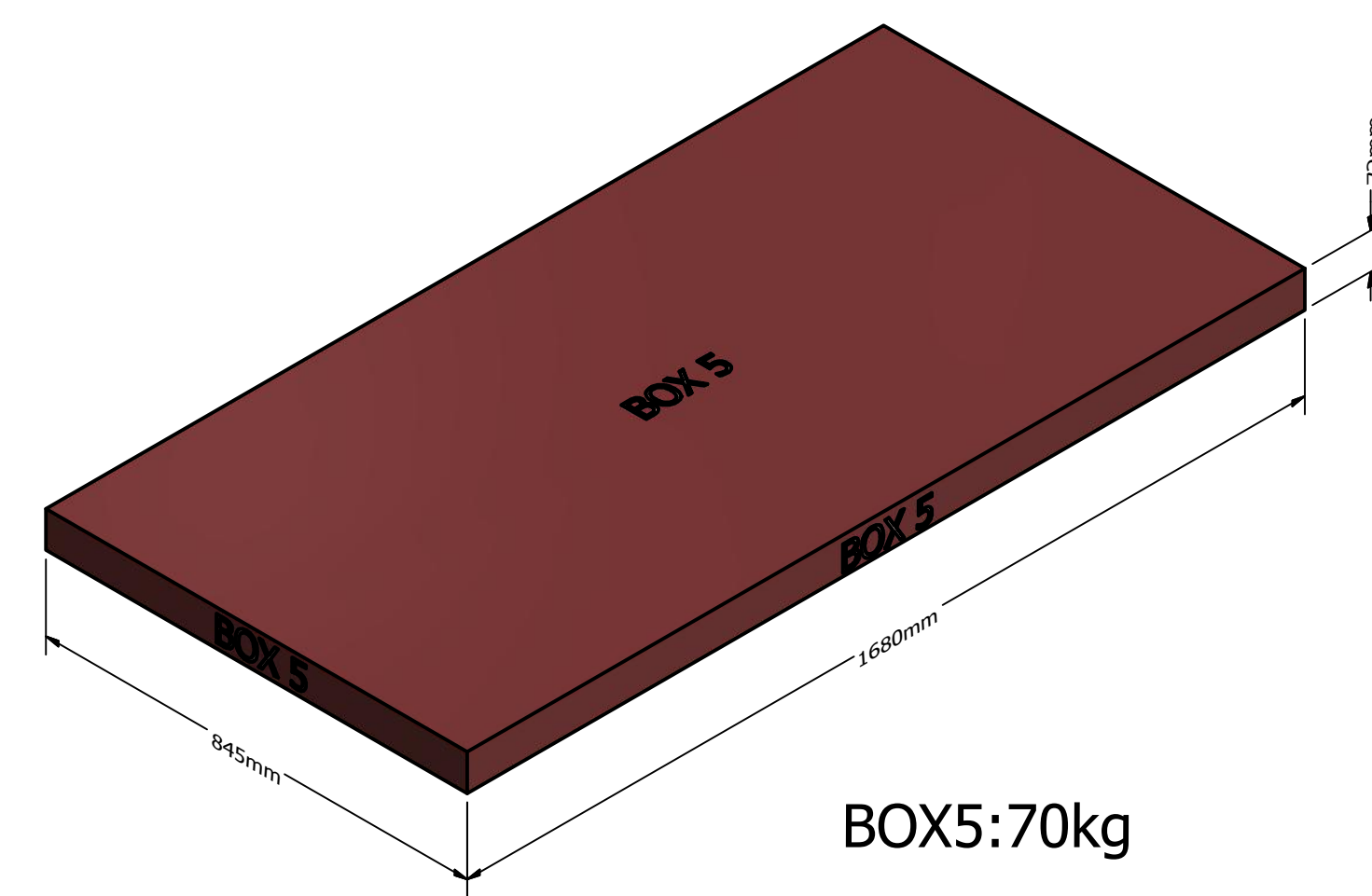

BOX5: 70kg

|               |           |                 |                         |     |
|---------------|-----------|-----------------|-------------------------|-----|
| DRAWN<br>Rudy | 2019/8/19 | TITLE           |                         |     |
| CHECKED       |           |                 |                         |     |
| QA            |           |                 |                         |     |
| MFG           |           |                 |                         |     |
| APPROVED      |           | SIZE<br>D       | DWG NO<br>Pallet A (详细) | REV |
|               |           | SCALE<br>1 / 10 | SHEET 1 OF 1            |     |

# 2106536D CORDOVA 14X10 配托用胶合板块

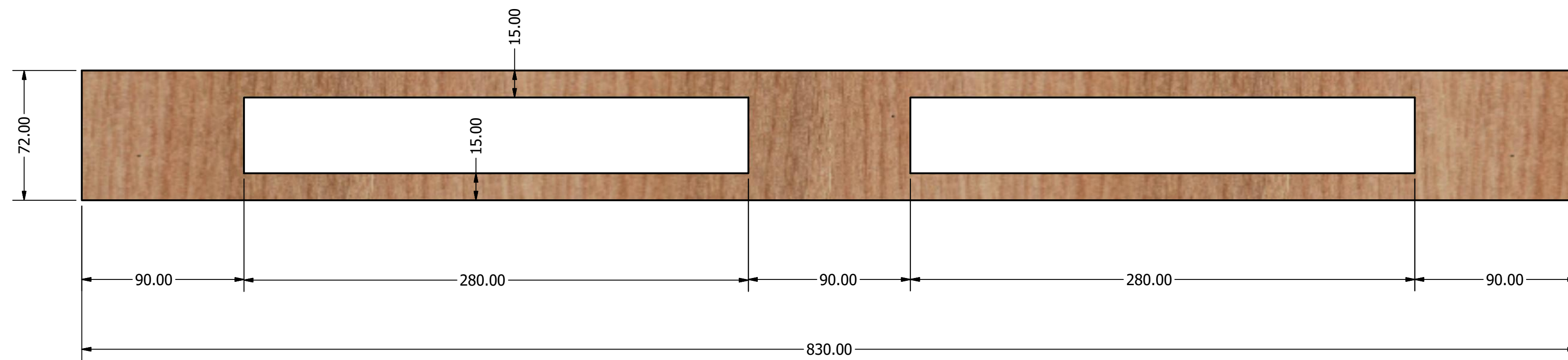
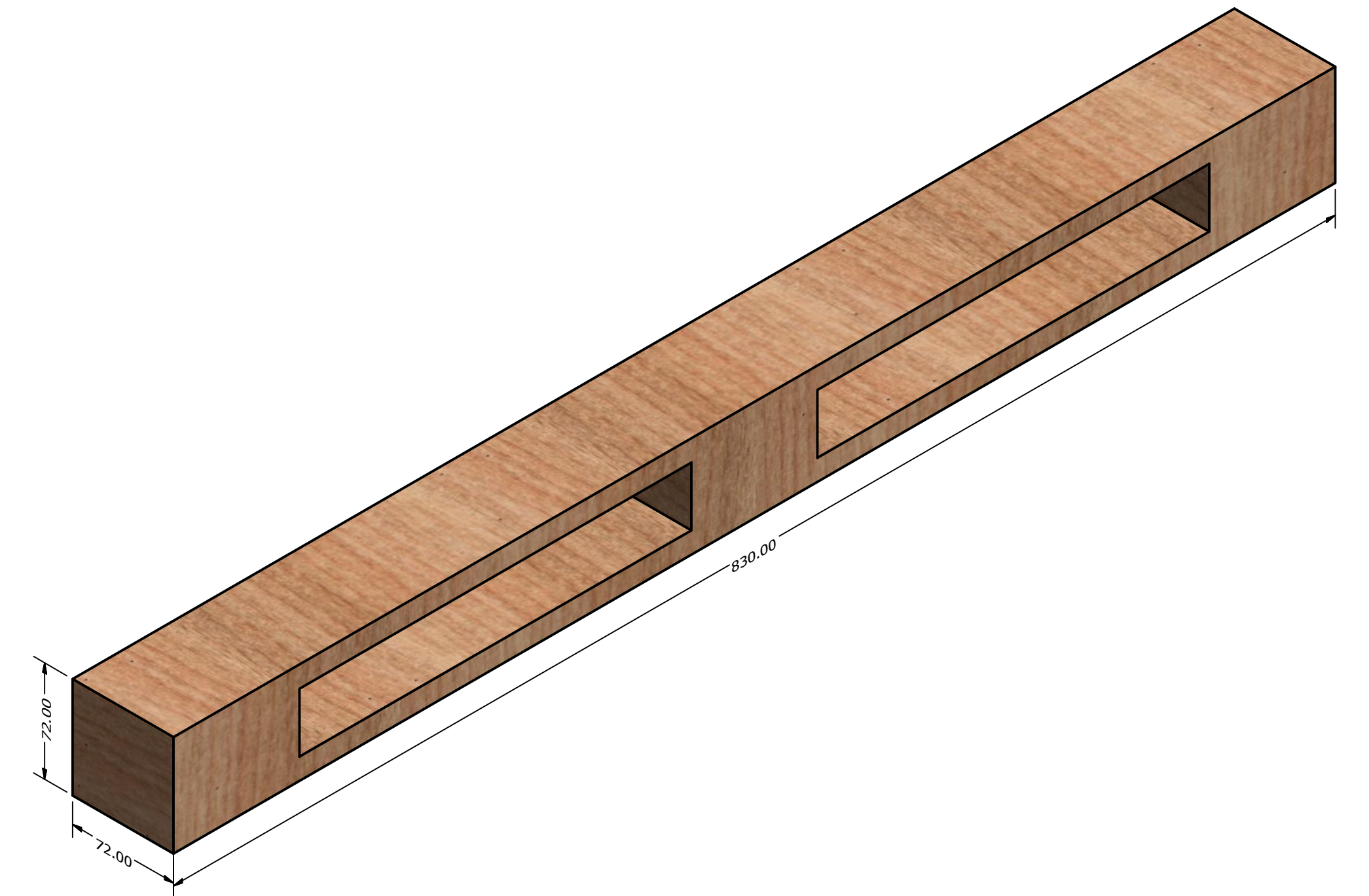

|          |       |          |       |              |
|----------|-------|----------|-------|--------------|
| DRAWN    | 41183 | 2022/2/7 |       |              |
| CHECKED  |       |          | TITLE |              |
| QA       |       |          |       |              |
| MFG      |       |          |       |              |
| APPROVED |       |          |       |              |
|          |       |          | SIZE  | DWG NO       |
|          |       |          | D     | 零件1          |
|          |       |          | SCALE | 1 / 2.5      |
|          |       |          |       | SHEET 1 OF 1 |