

2304161 PALISADE OUTDOOR BAR Container Loading Diagram

(1 set=3 boxes, 73 sets/40HQ, 20 pallets/ 40HQ, Gross Weight:20291kg)

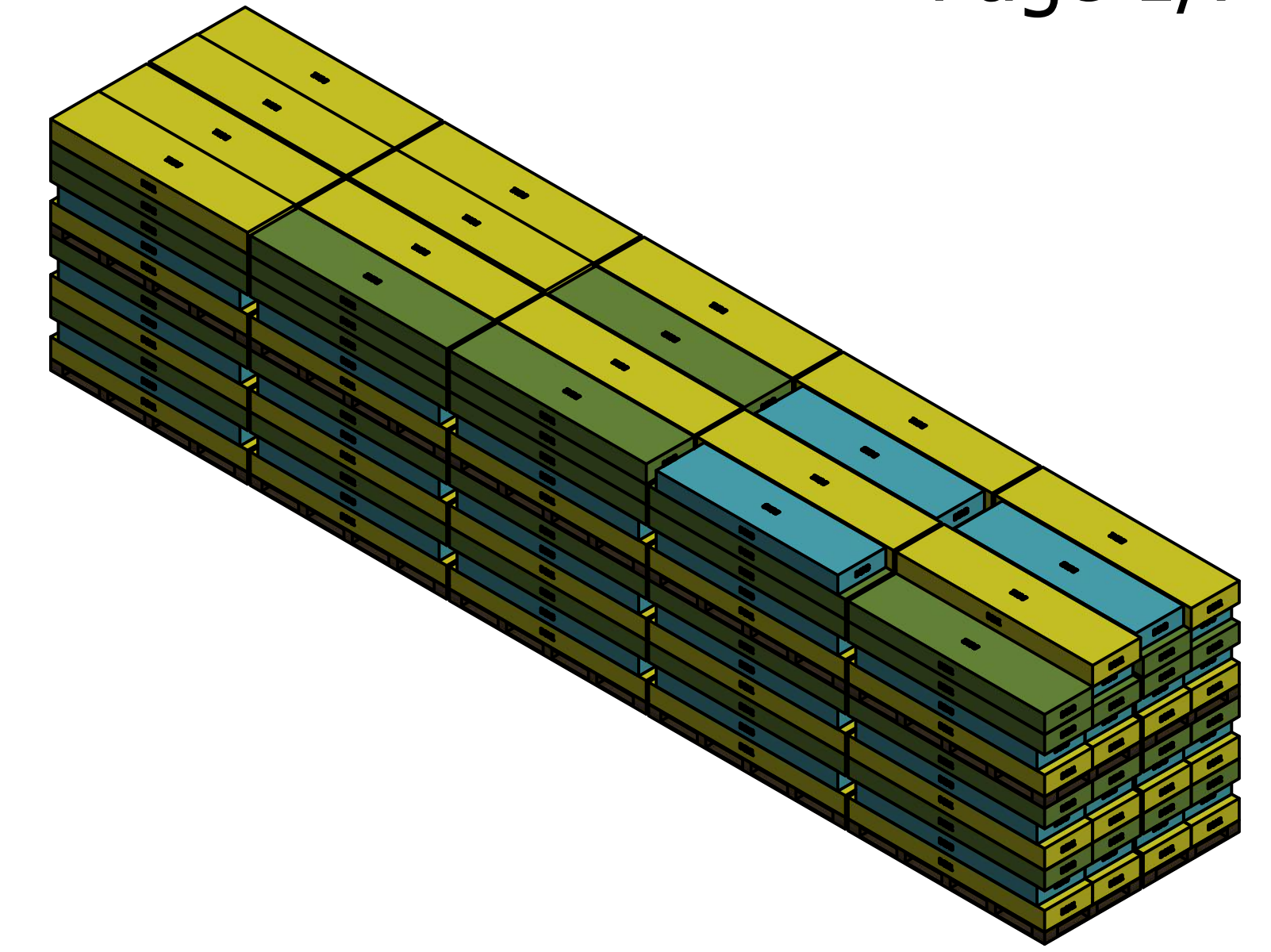

Top view

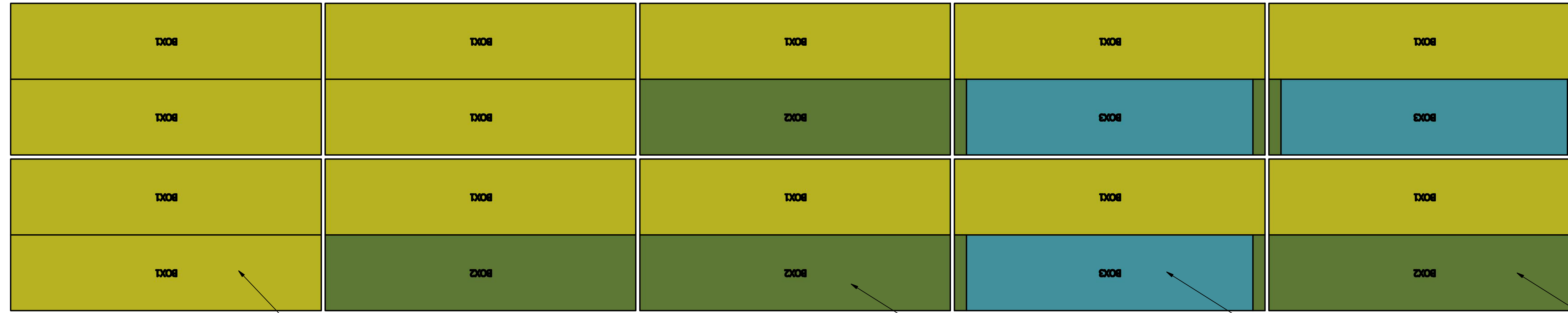

Pallet C * 3

Pallet D * 3

Pallet E * 3

Pallet B * 1

Side view

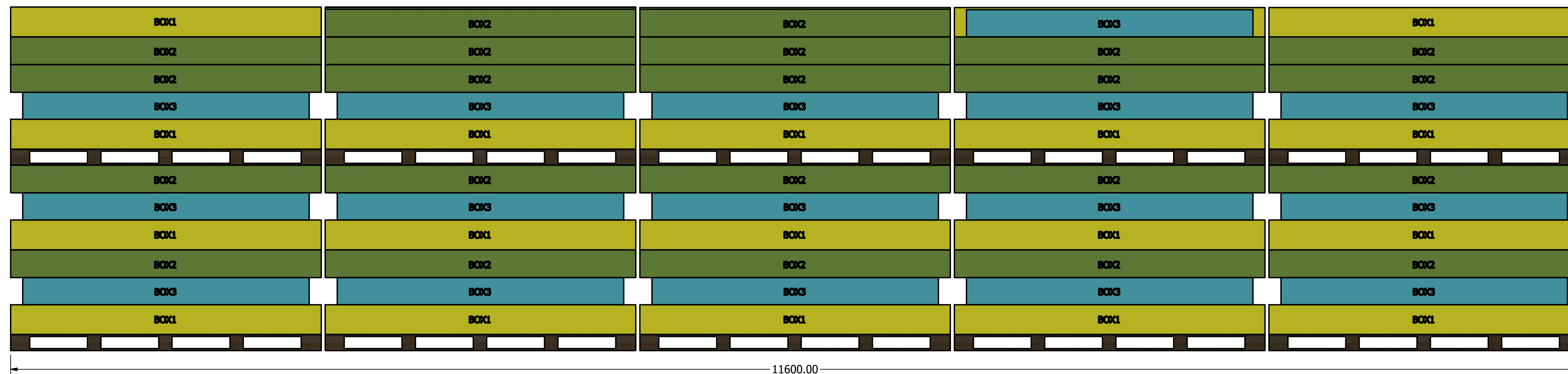

11600.00

End view

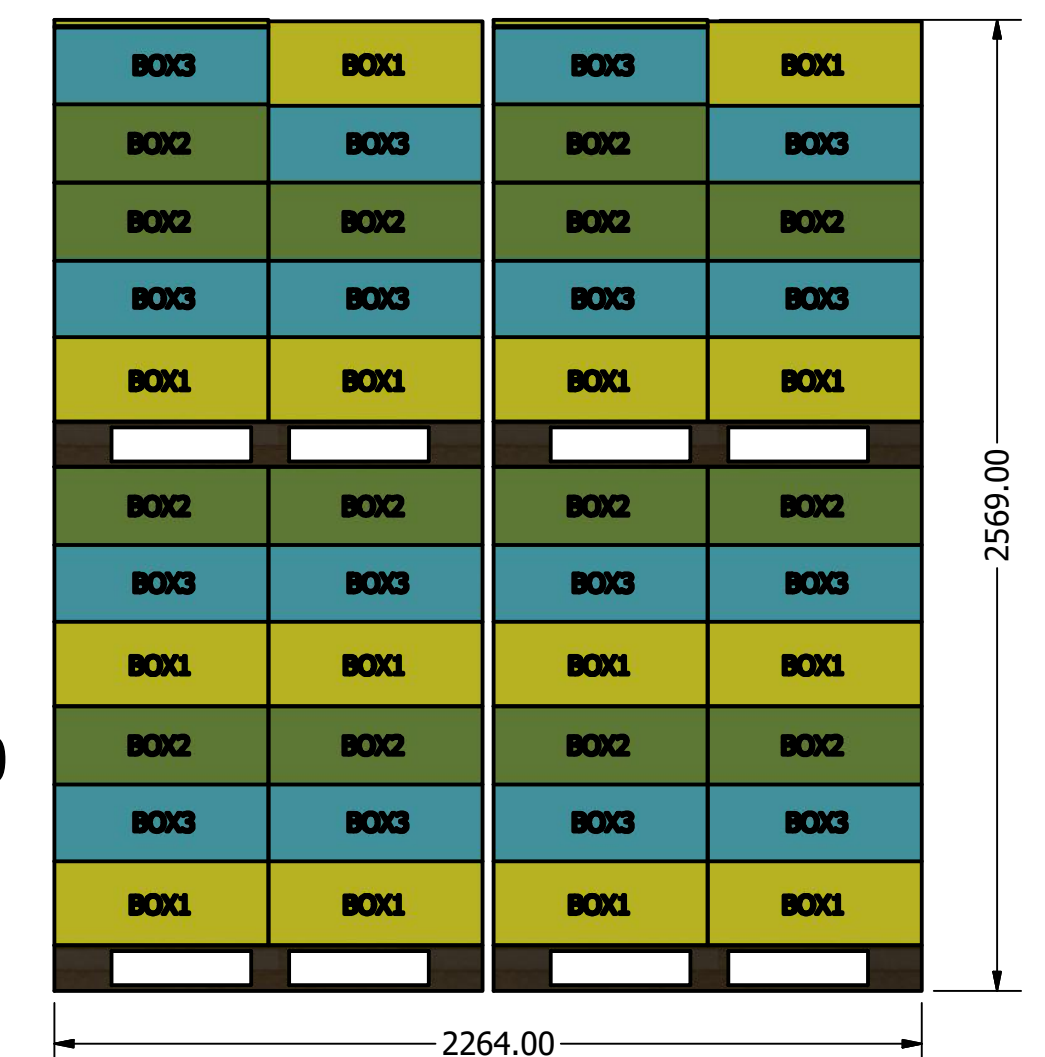

2569.00

2264.00

Pallet A * 10

DRAWN Rudy		TITLE		
CHECKED				
QA		DWG NO		
MFG				
APPROVED		SIZE D	REV	
SCALE 1 / 20		SHEET 1 OF 1		

Pallet A detail (4 sets)

Top View

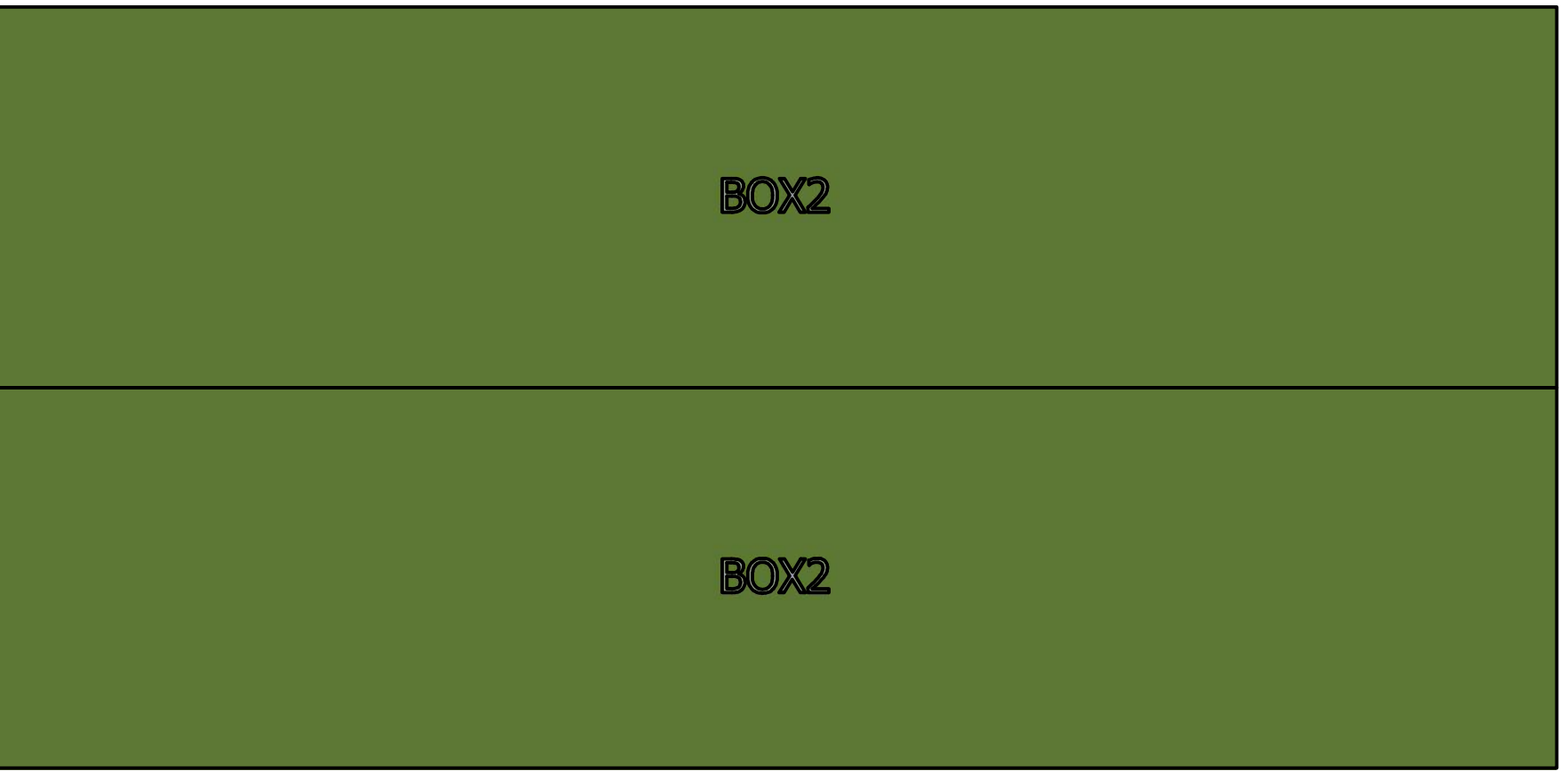

Side View

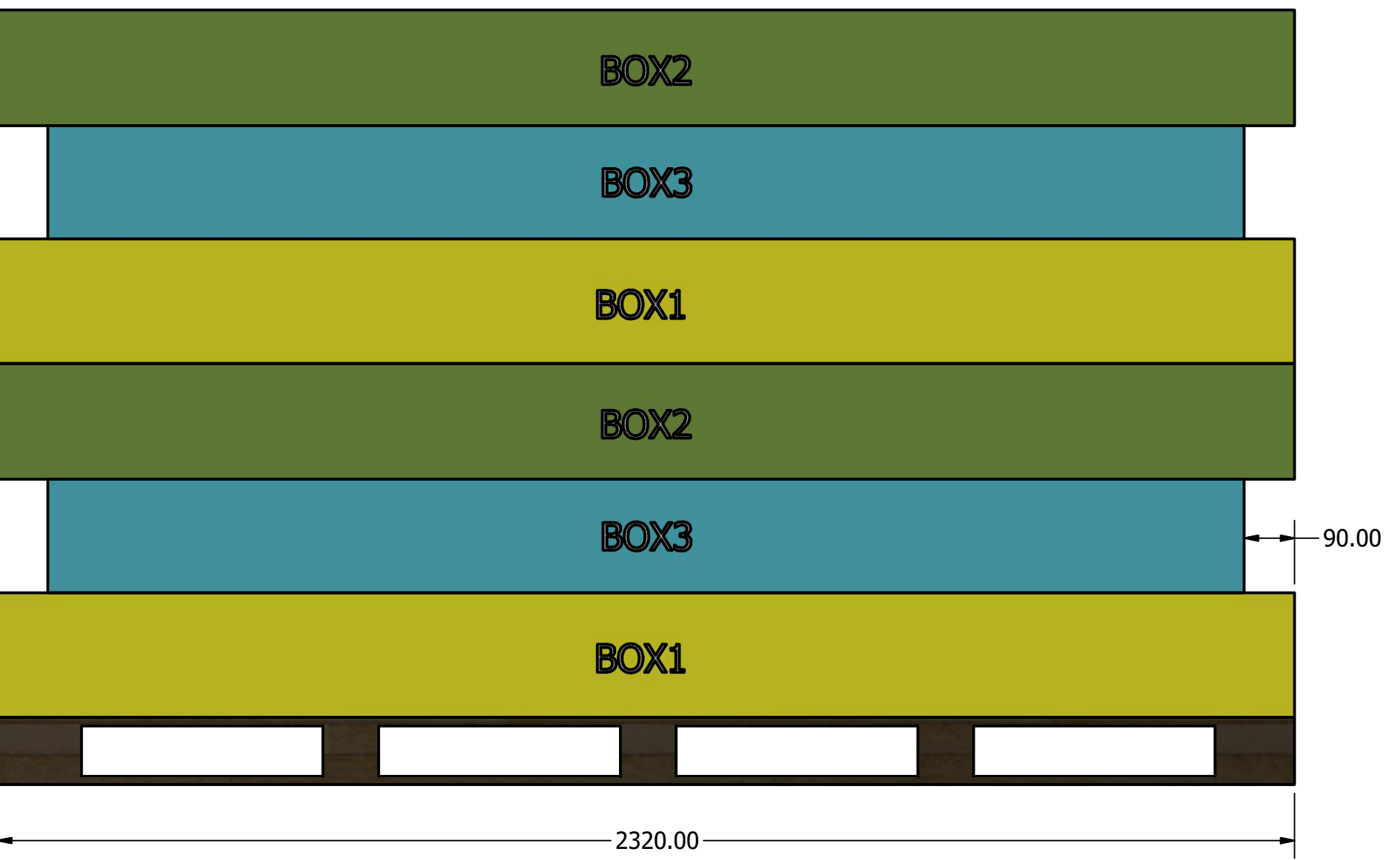

End View

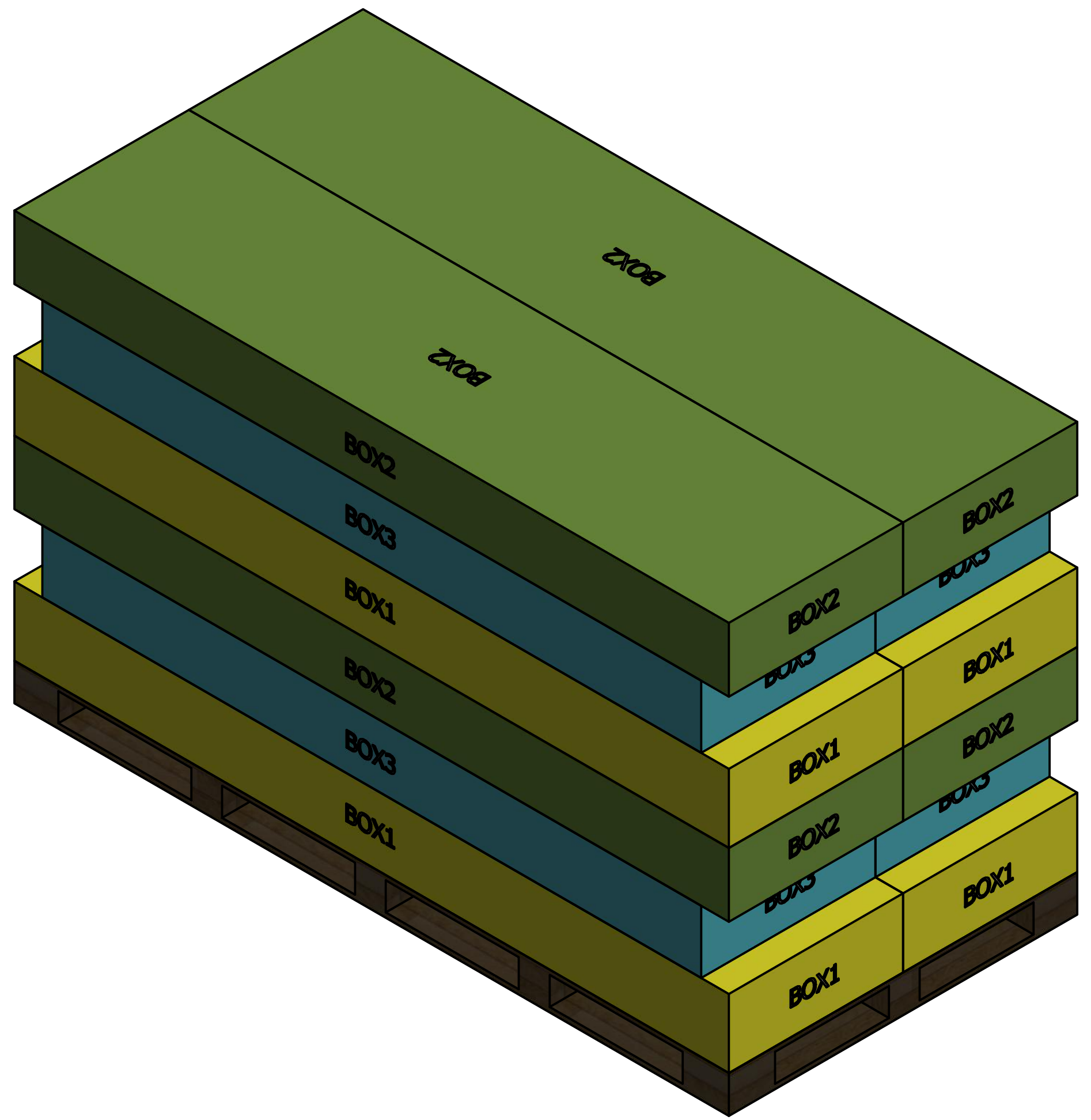
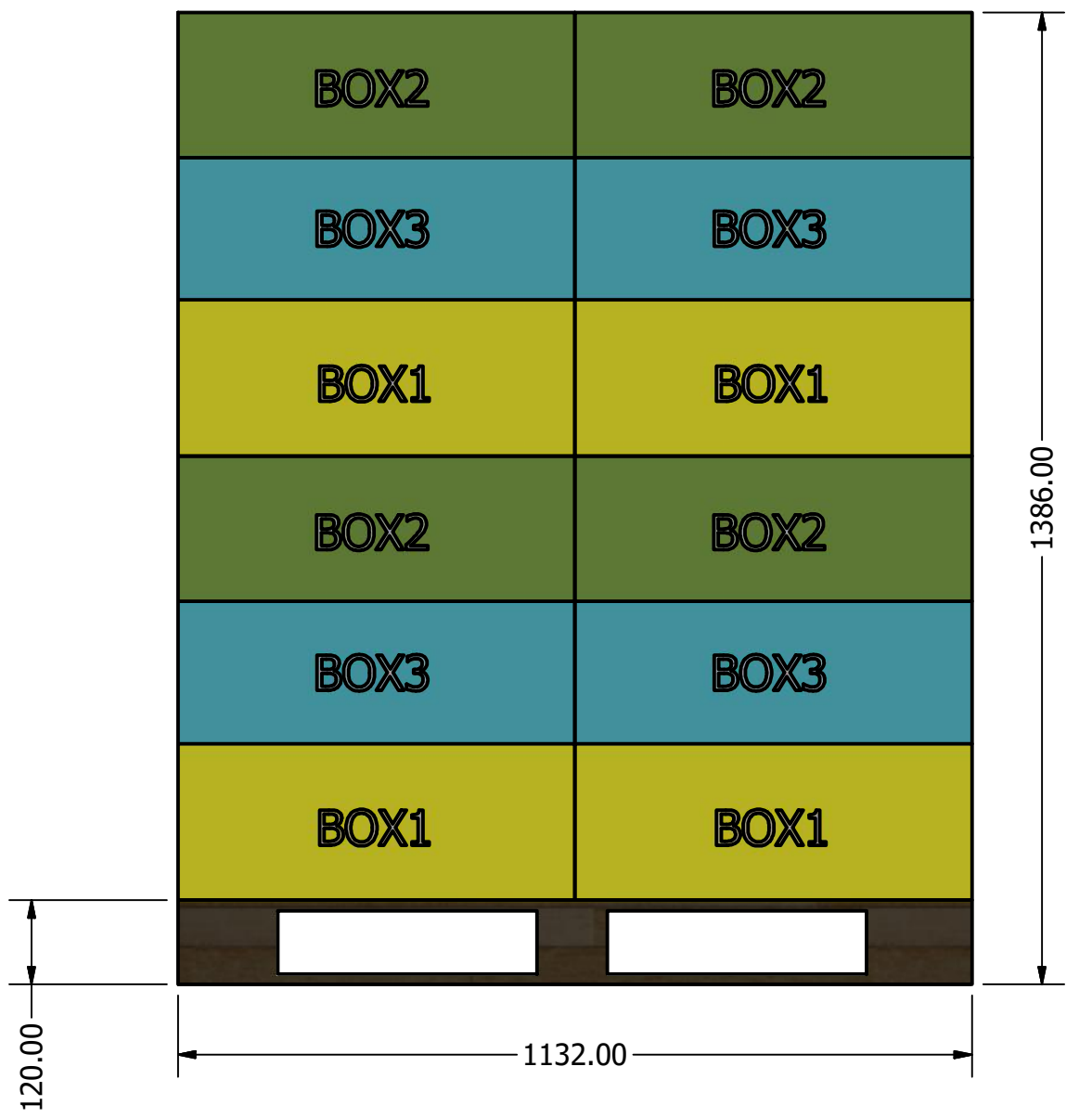

DRAWN Rudy	2019-12-16		
CHECKED		TITLE	
QA			
MFG			
APPROVED			
		SIZE D	DWG NO Pallet A
		SCALE 0.1 : 1	REV
		SHEET 1 OF 1	

Pallet B detail (3 sets)

Top View

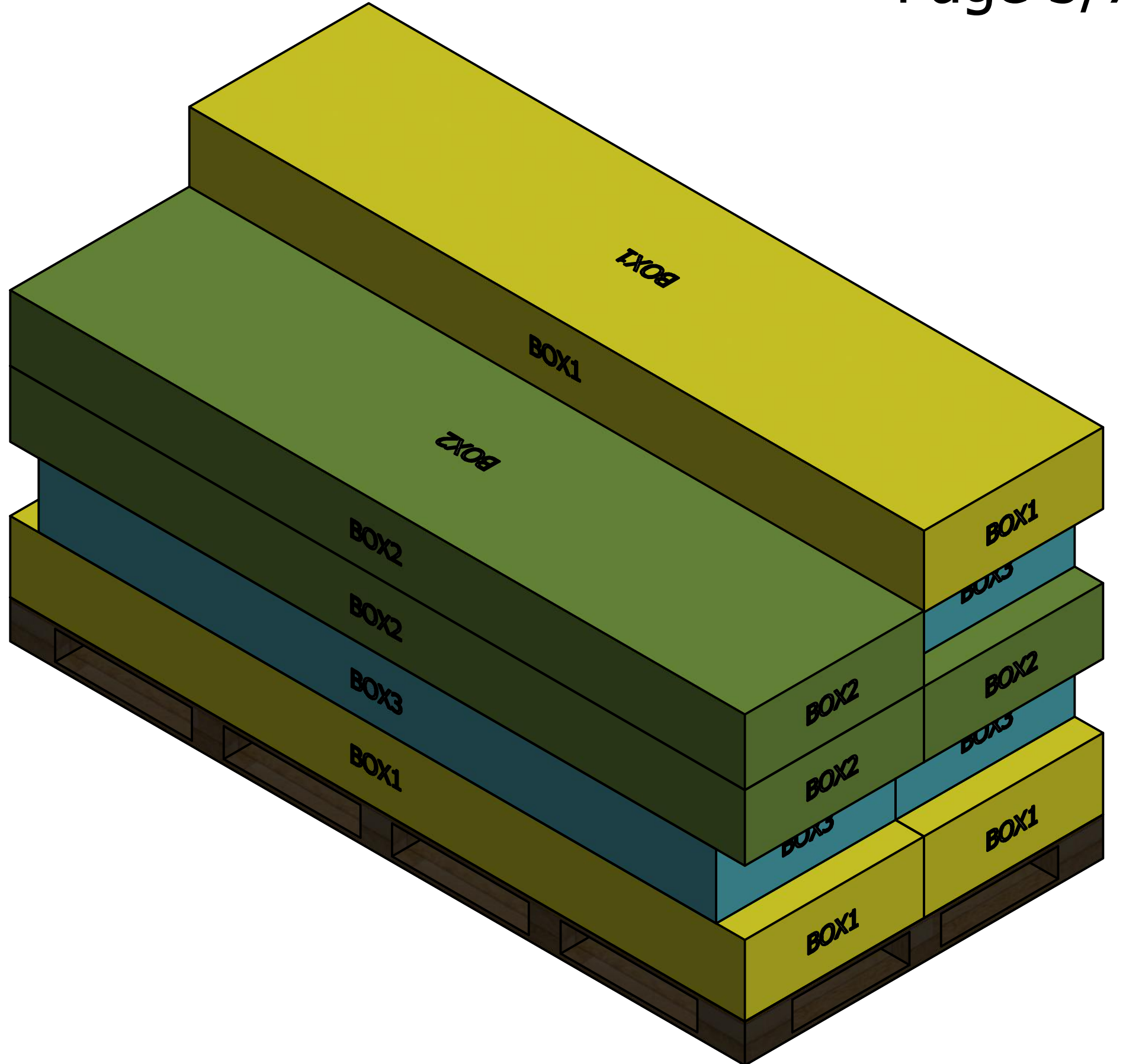
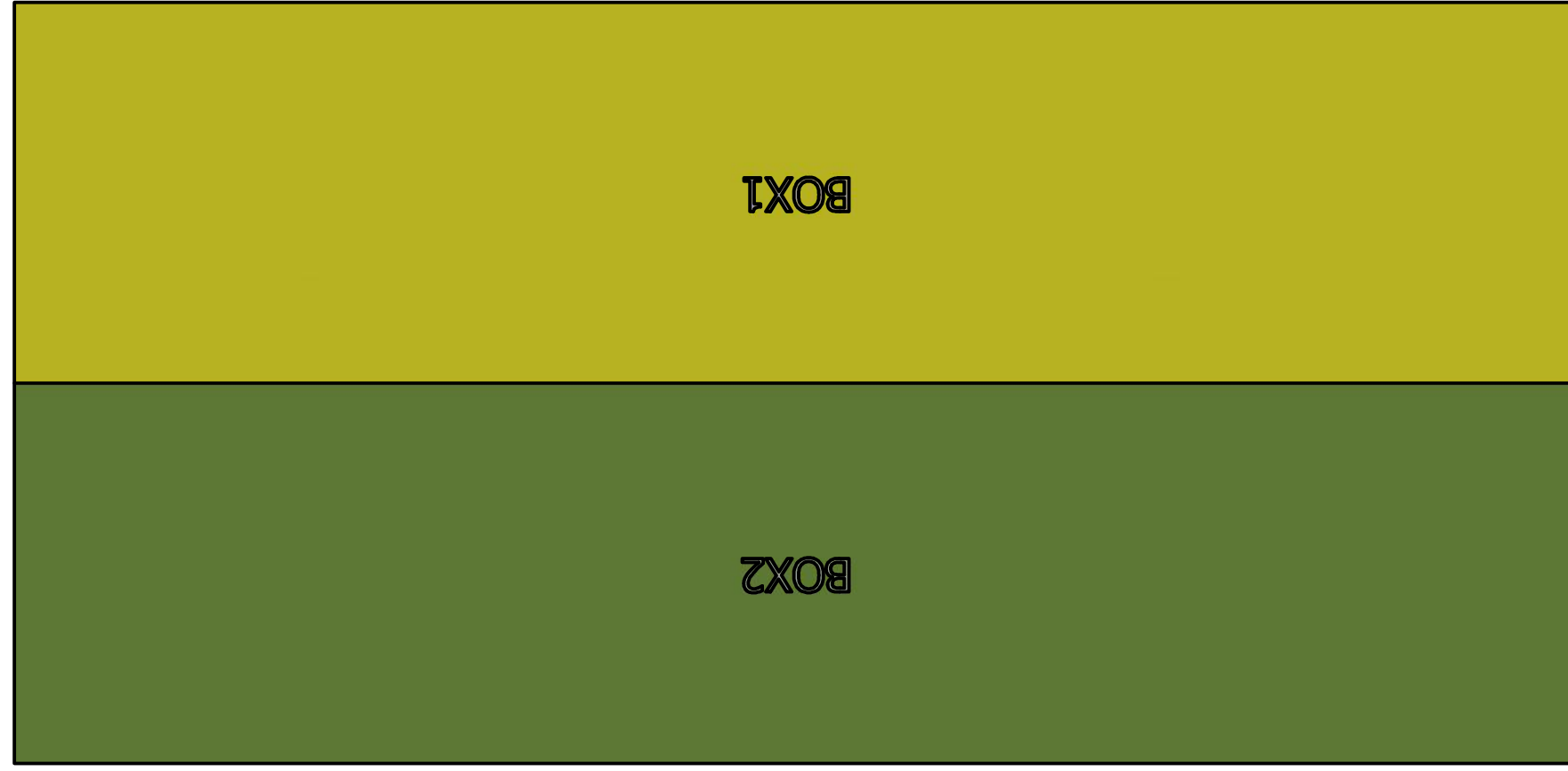

Side View

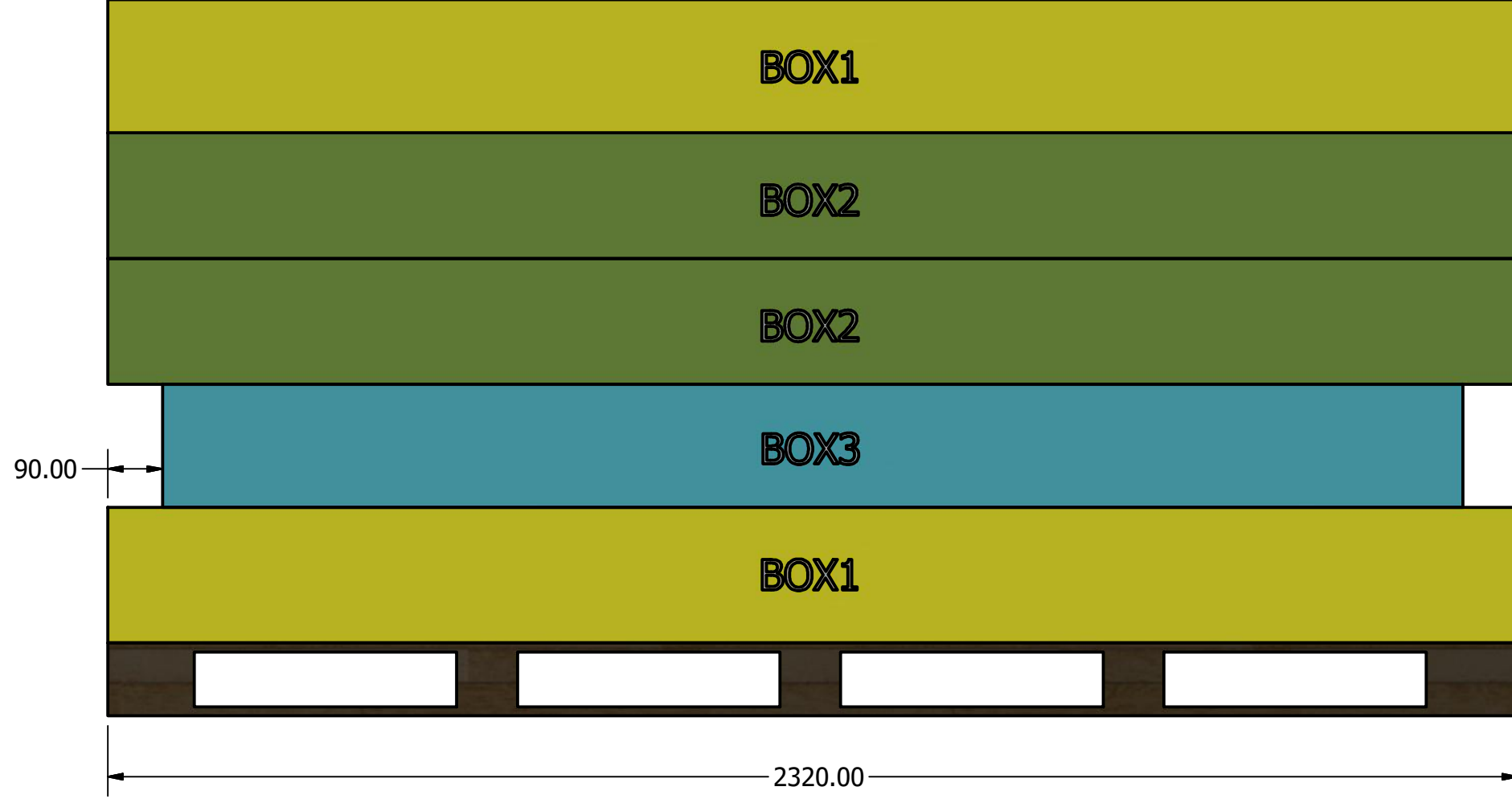

End View

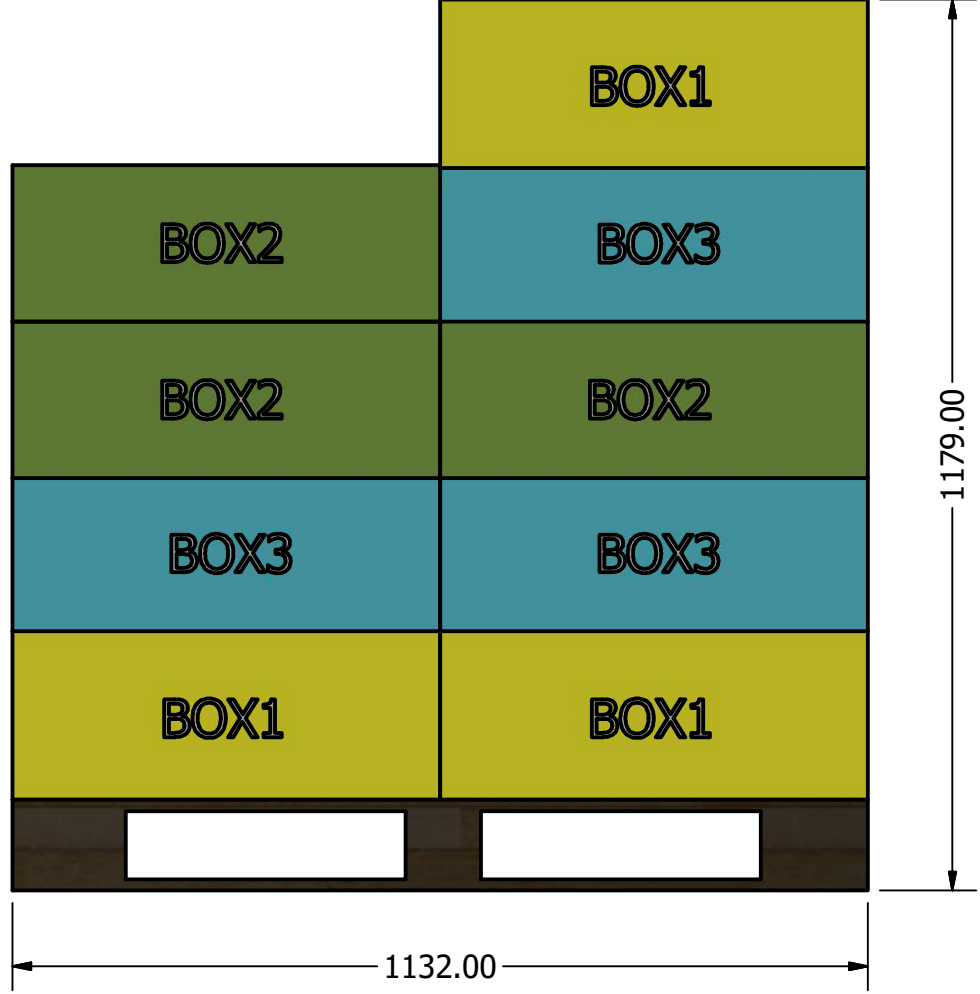

DRAWN	Rudy	2019-12-16		
CHECKED			TITLE	
QA				
MFG				
APPROVED				
			SIZE	DWG NO
			D	Pallet A
			SCALE	1 : 10
				SHEET 1 OF 1

Pallet C detail (3 sets+BOX1*1)

Top View

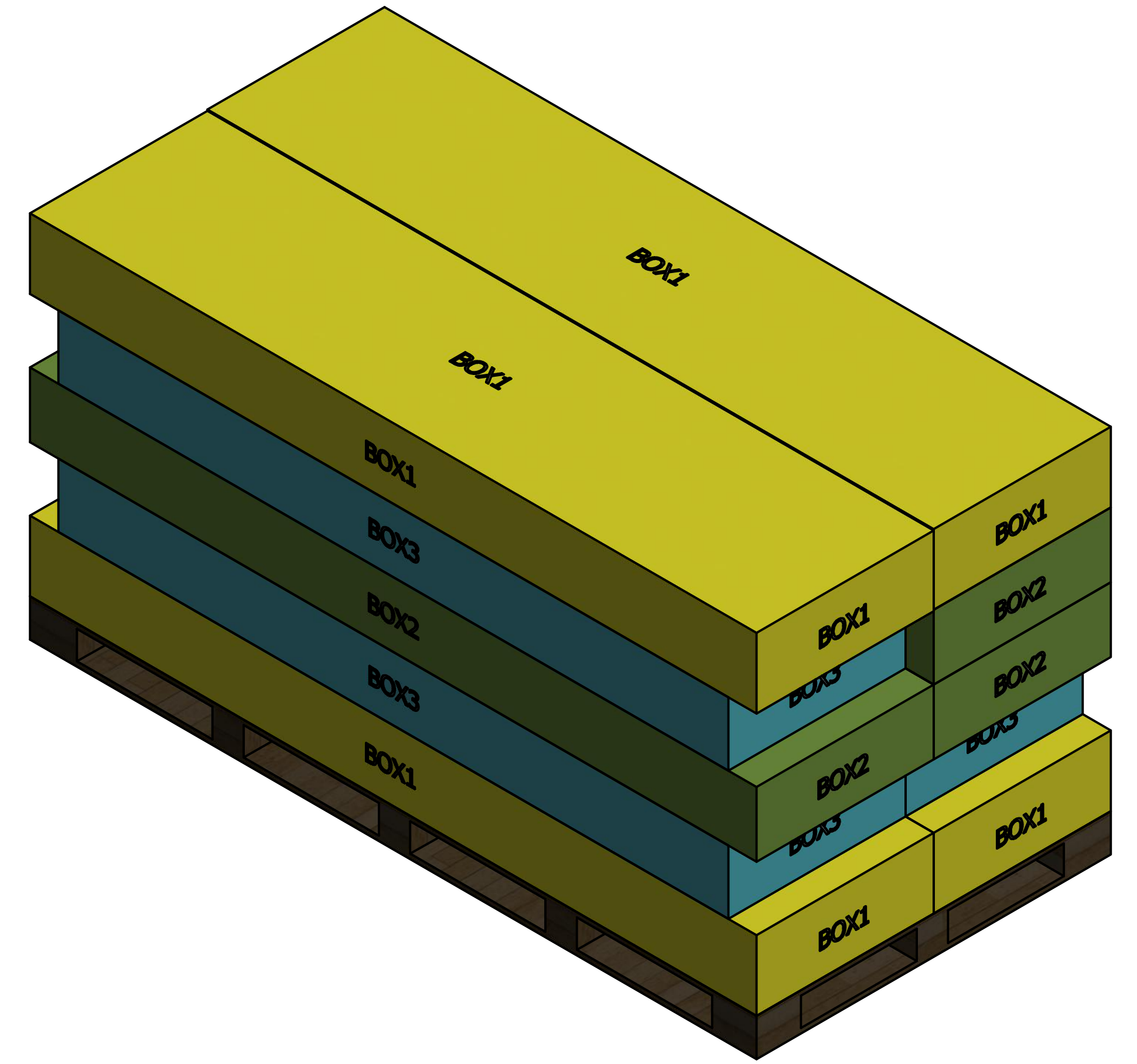
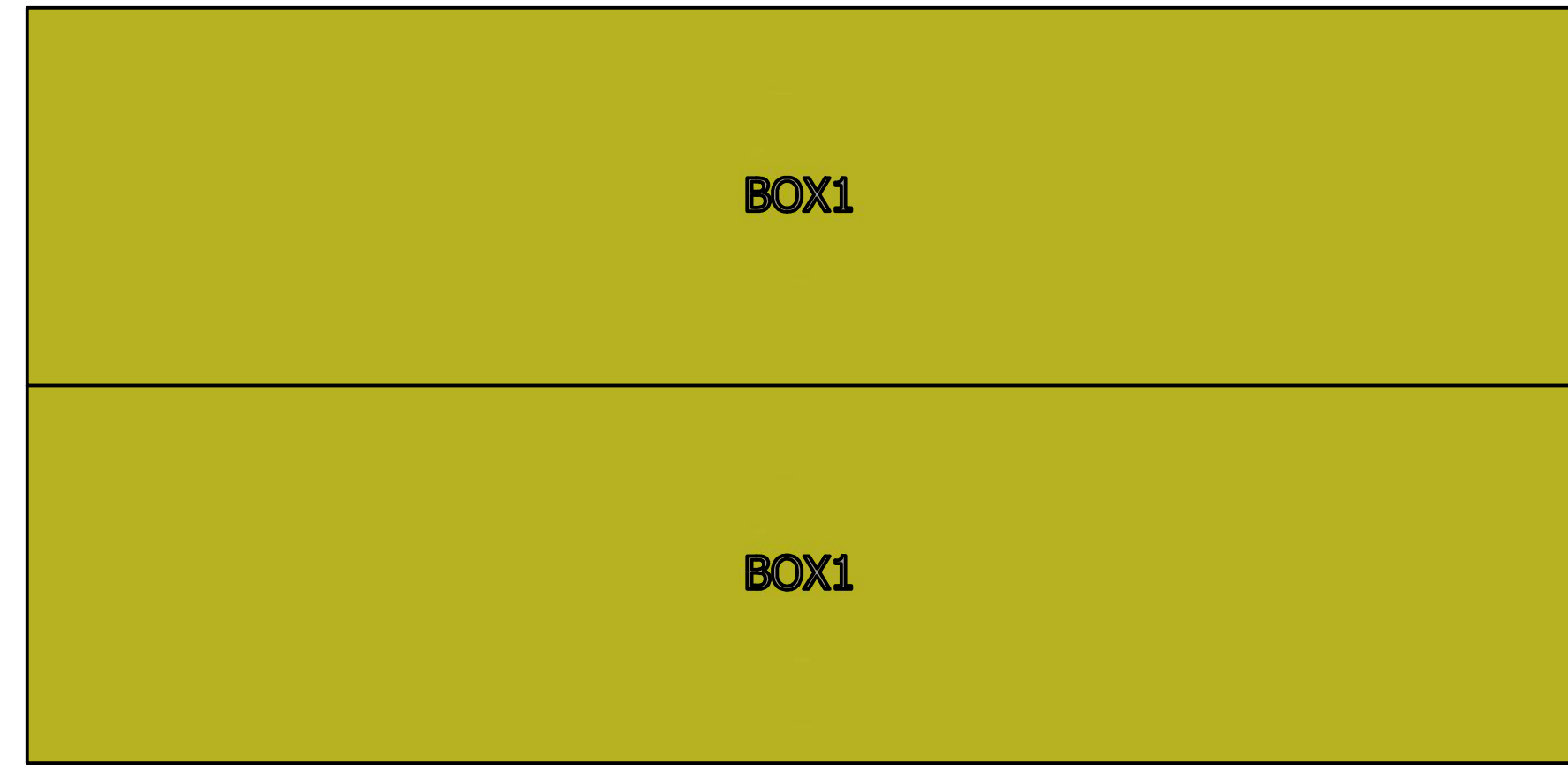

Side View

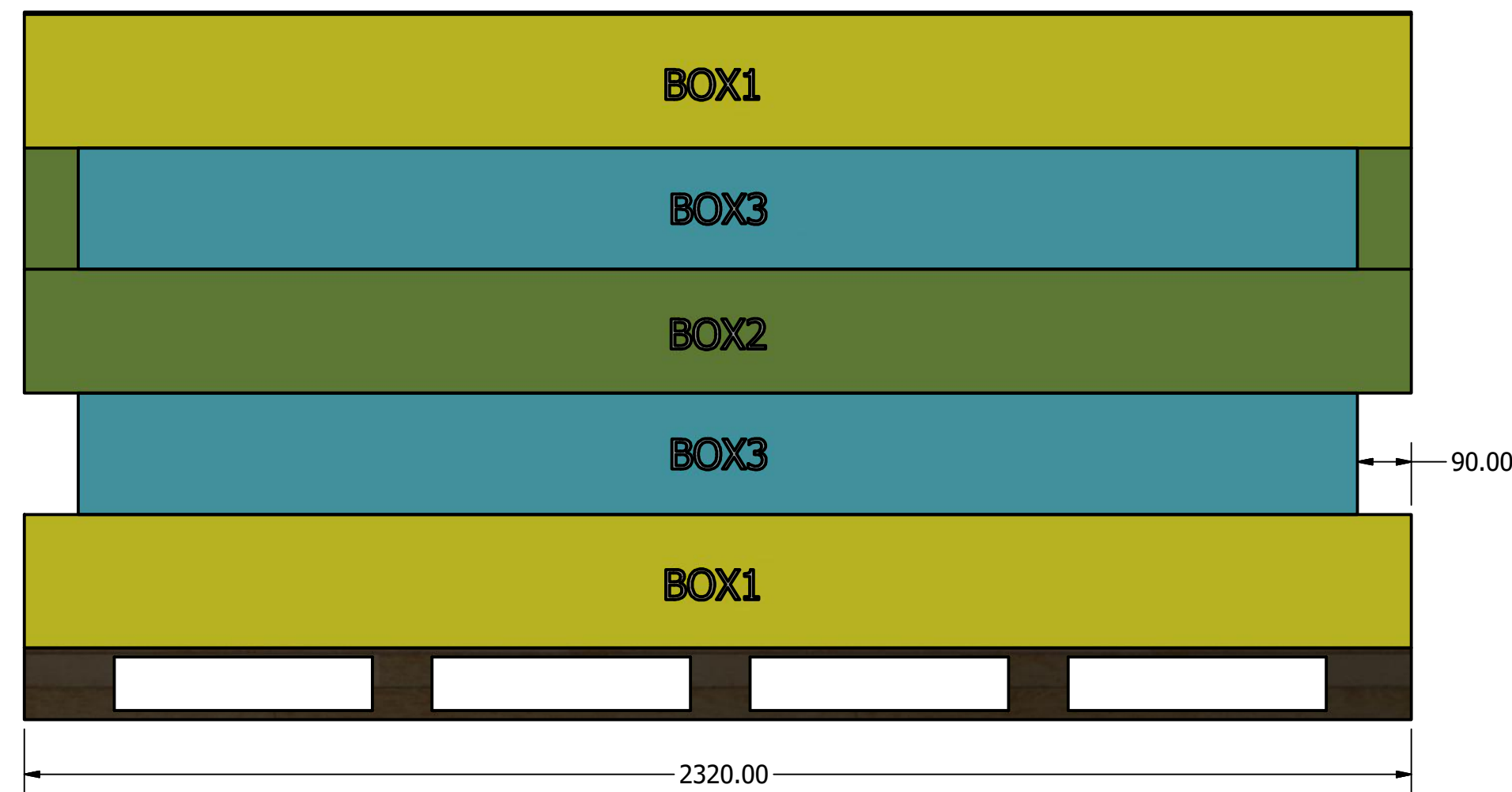

End View

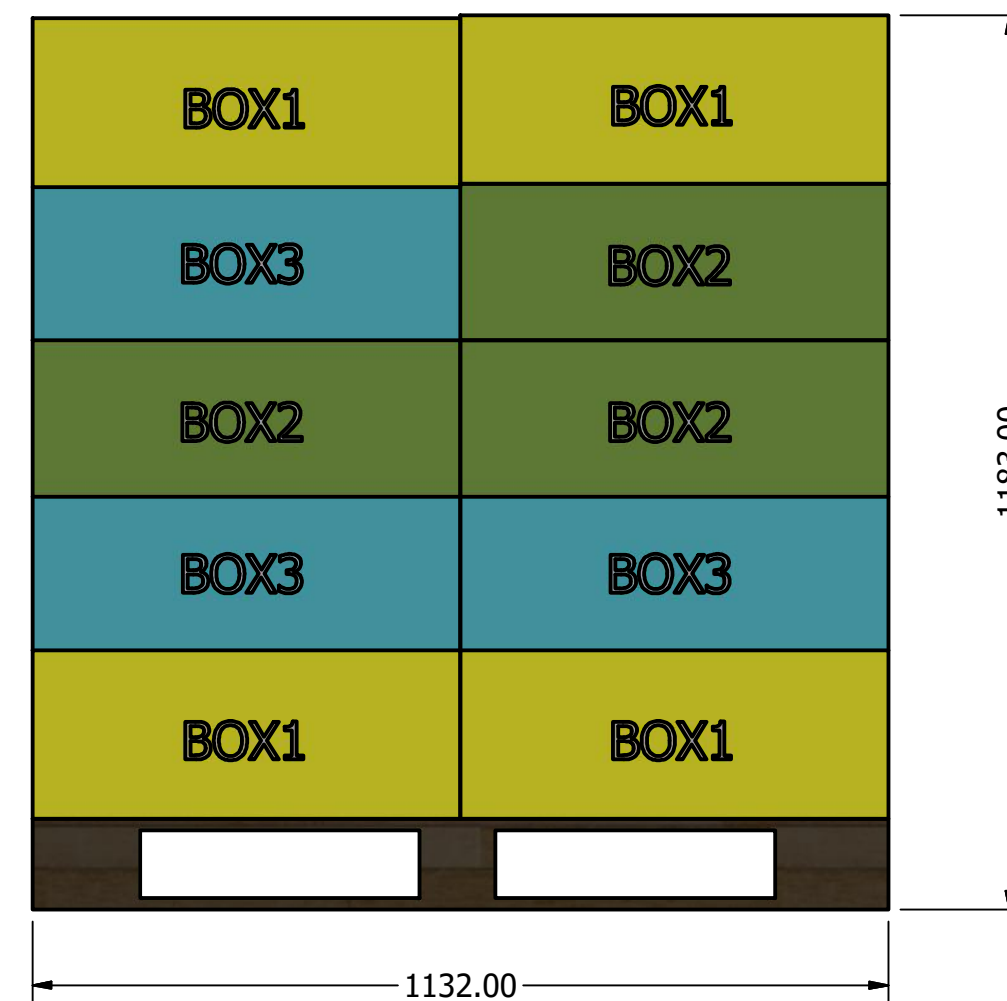

DRAWN Rudy	2019-12-16		
CHECKED		TITLE	
QA			
MFG			
APPROVED			
		SIZE D	DWG NO Pallet A
		SCALE 1 : 10	REV
		SHEET 1 OF 1	

Pallet D detail (3 sets+BOX2*1)

Top View

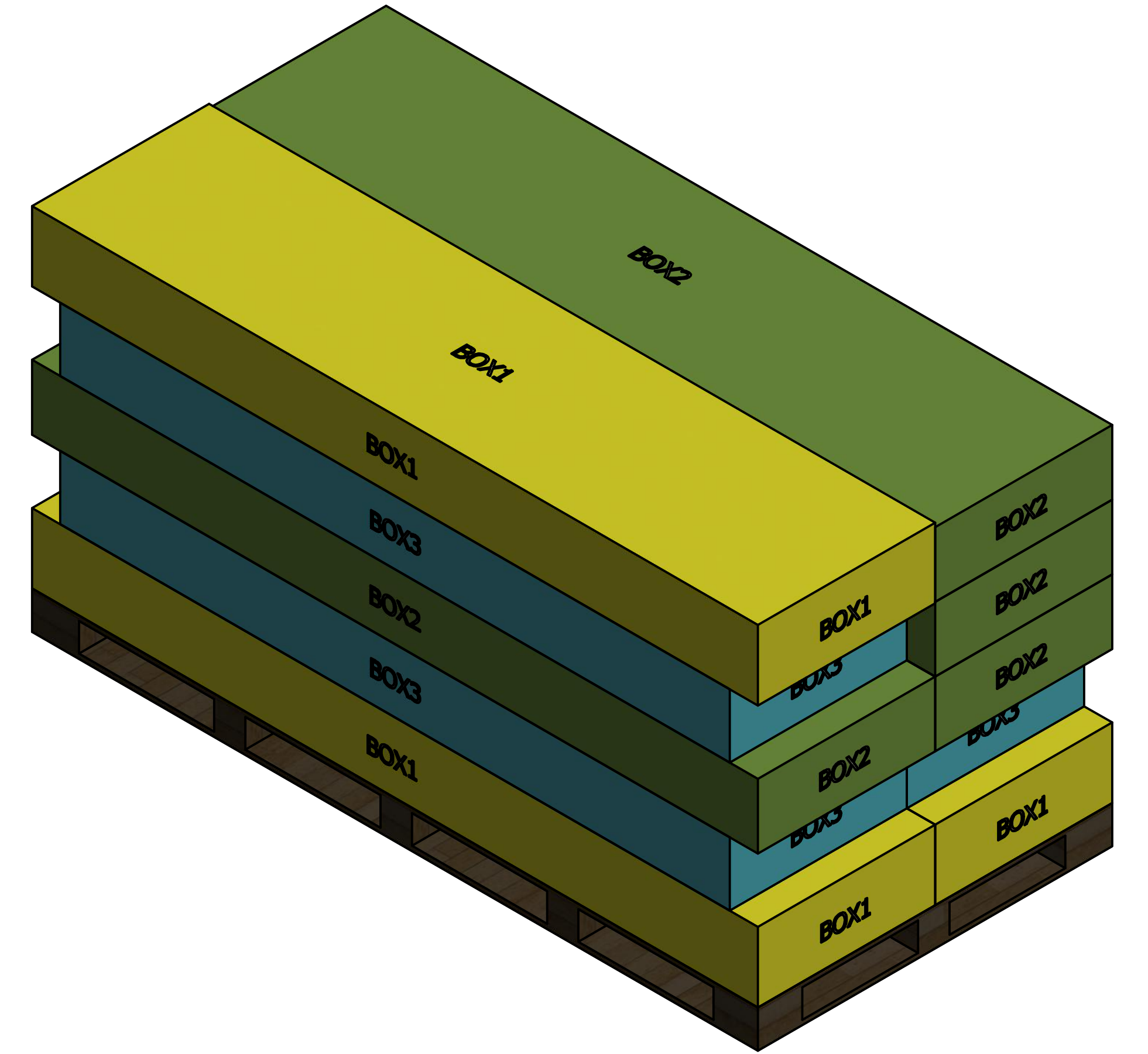

Side View

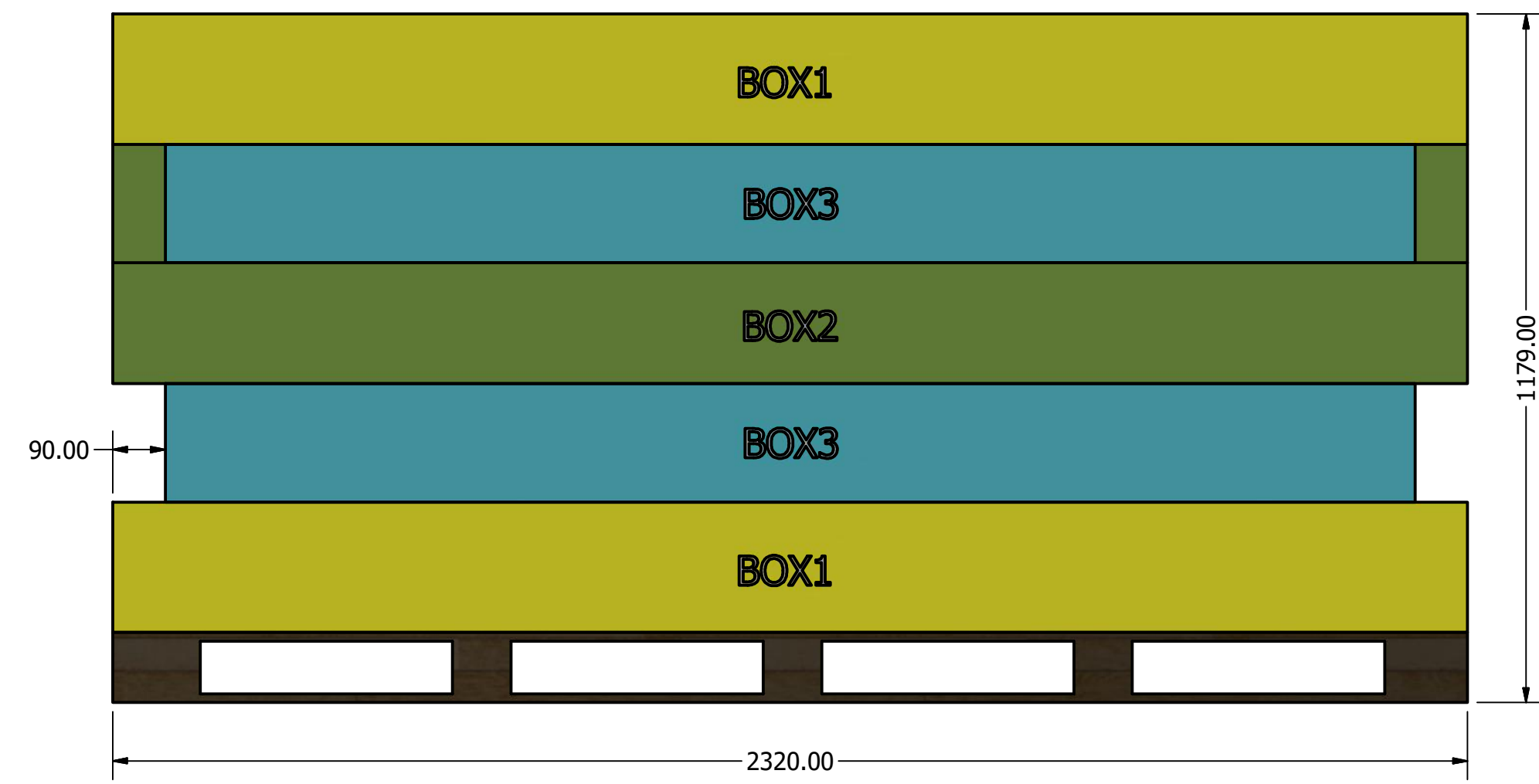

End View

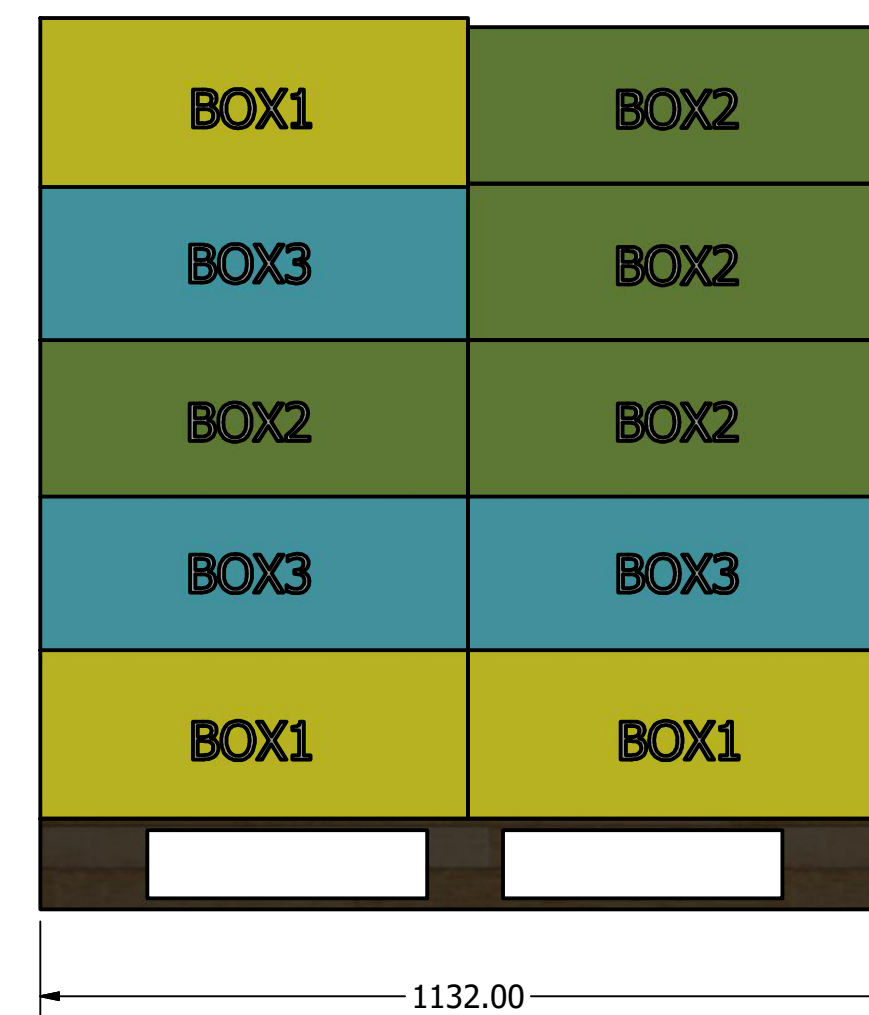

DRAWN Rudy	2019-12-16		
CHECKED		TITLE	
QA			
MFG			
APPROVED			
		SIZE D	DWG NO Pallet A
		SCALE 1:10	REV
		SHEET 1 OF 1	

Pallet E detail (3 sets+BOX3*1)

Top View

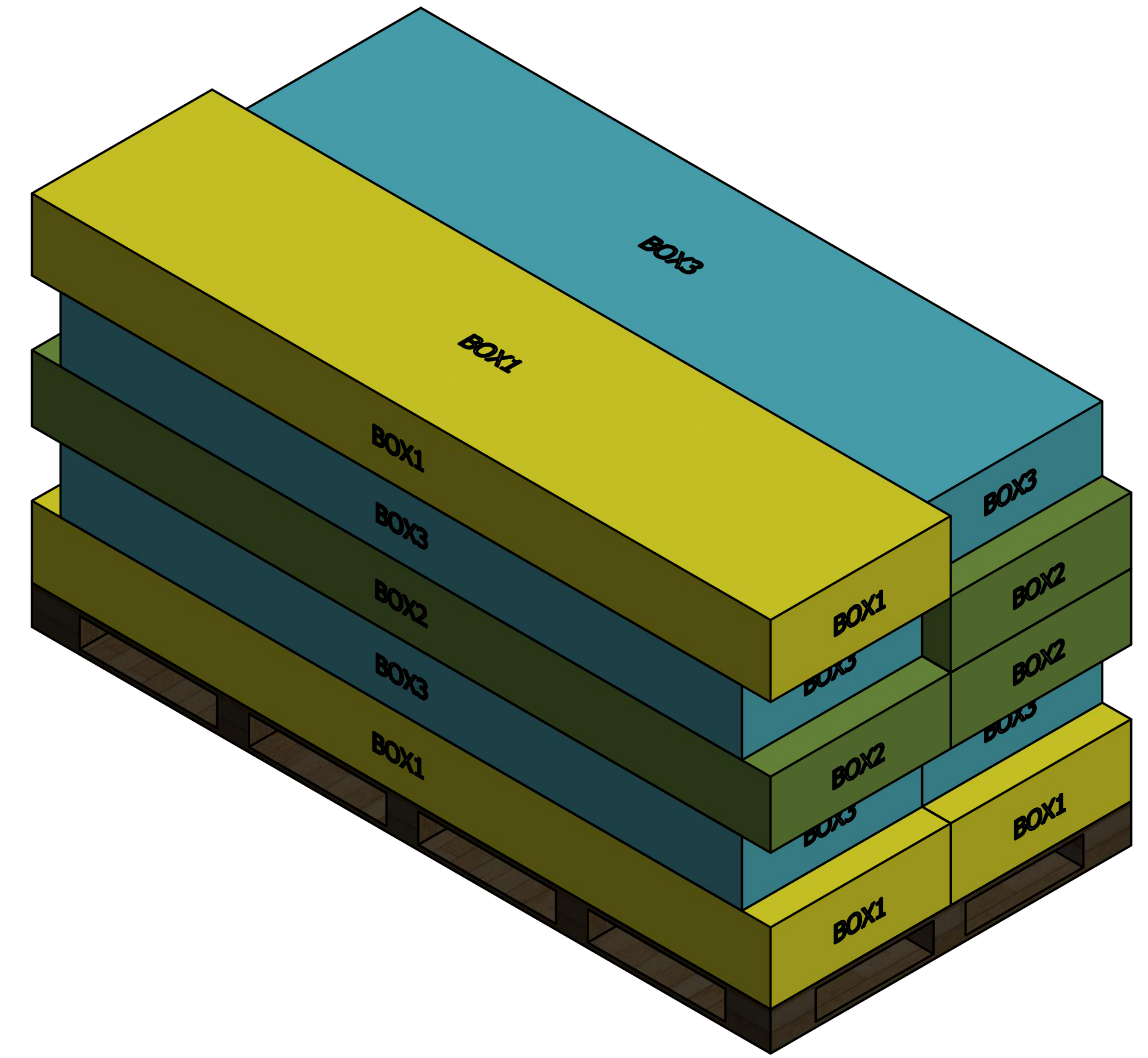
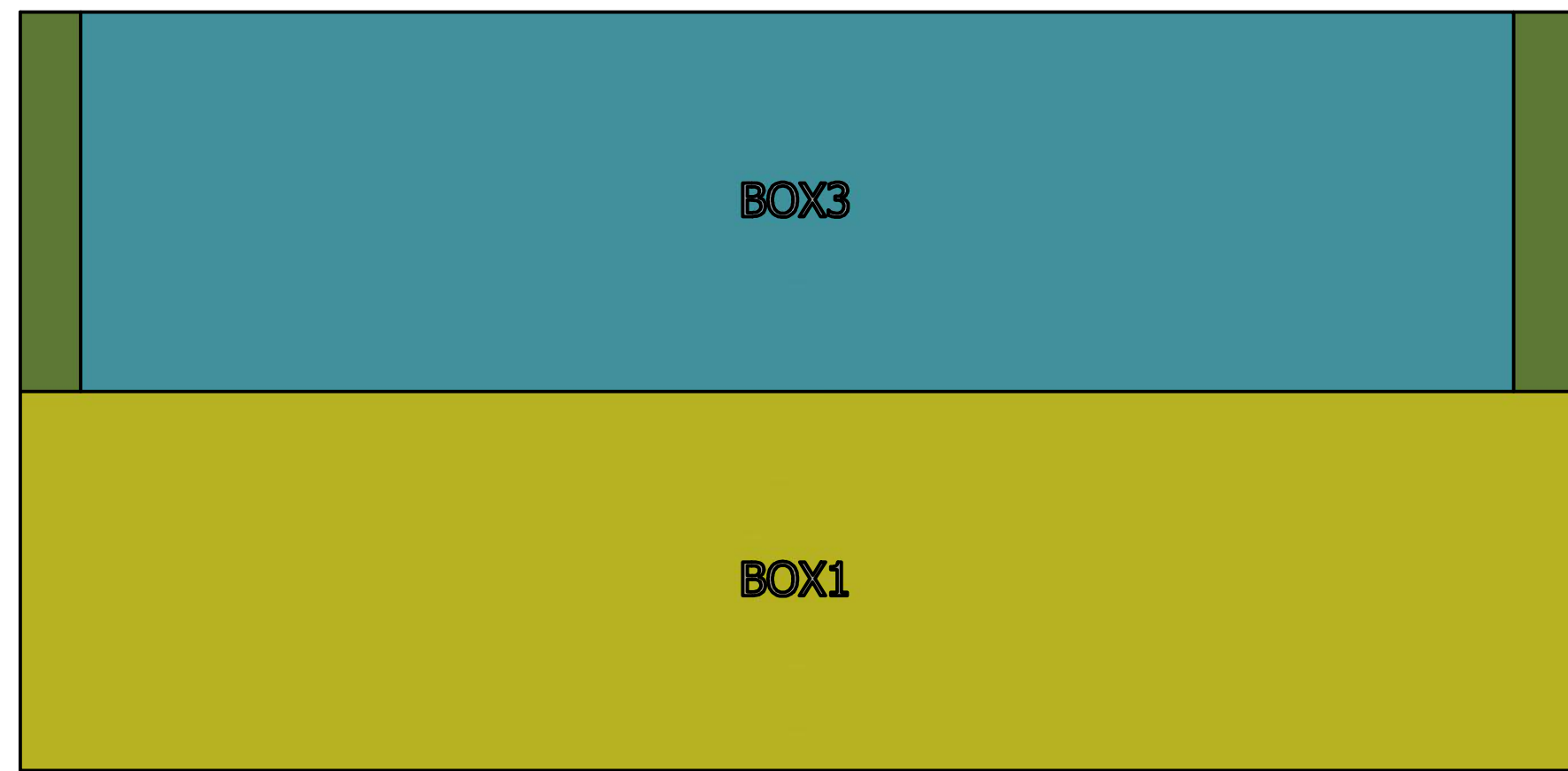

Side View

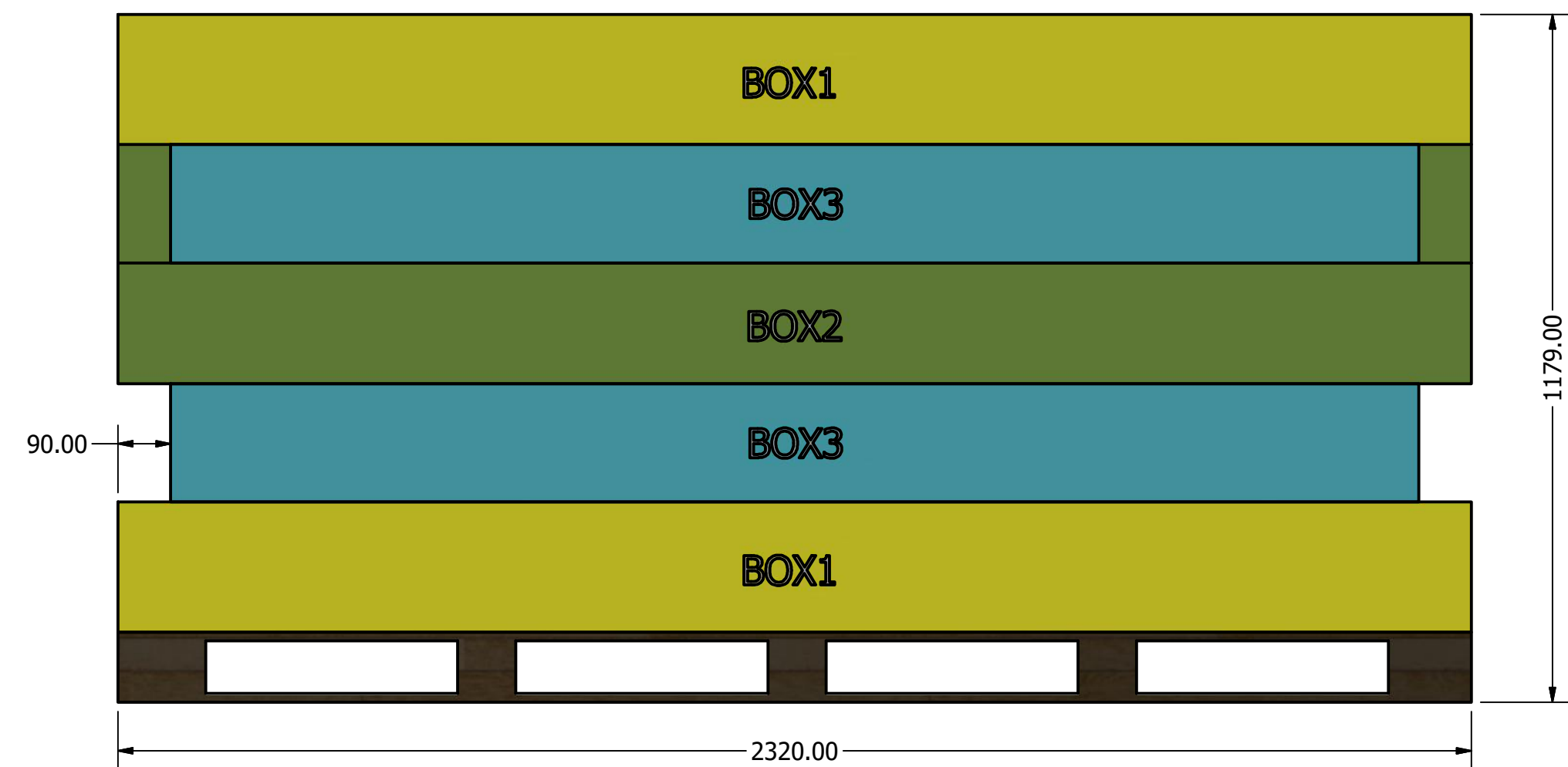

End View

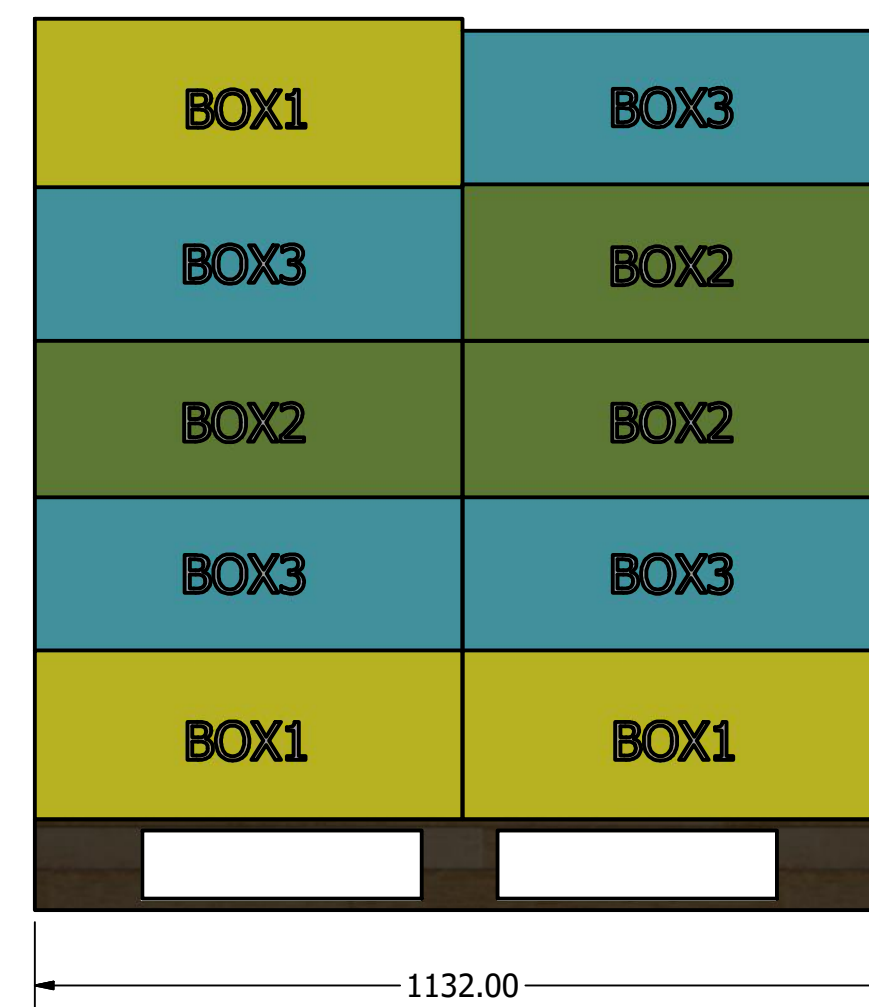

DRAWN Rudy	2019-12-16		
CHECKED		TITLE	
QA			
MFG			
APPROVED			
		SIZE D	DWG NO Pallet A
		SCALE 1 : 10	REV
		SHEET 1 OF 1	

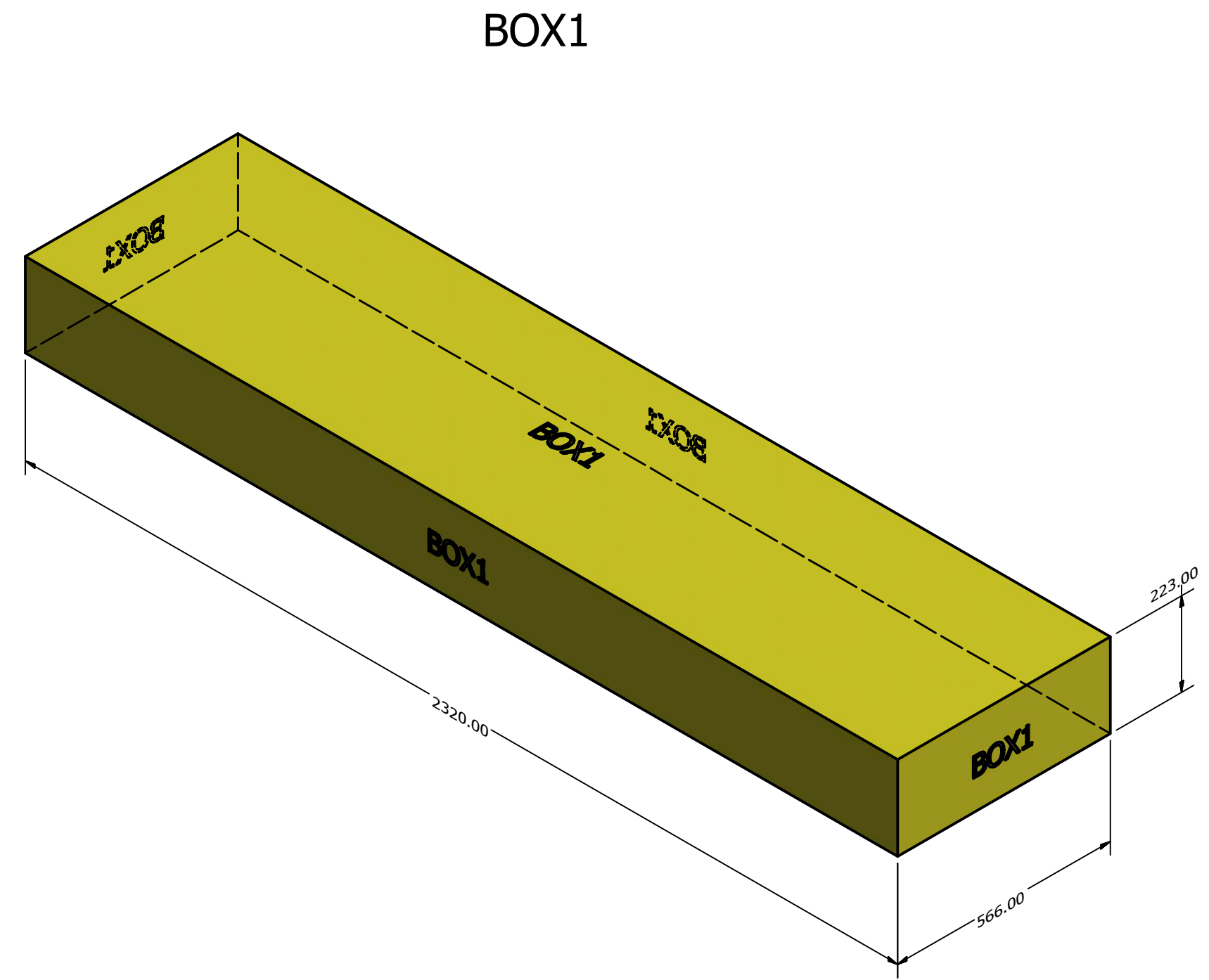

97kg

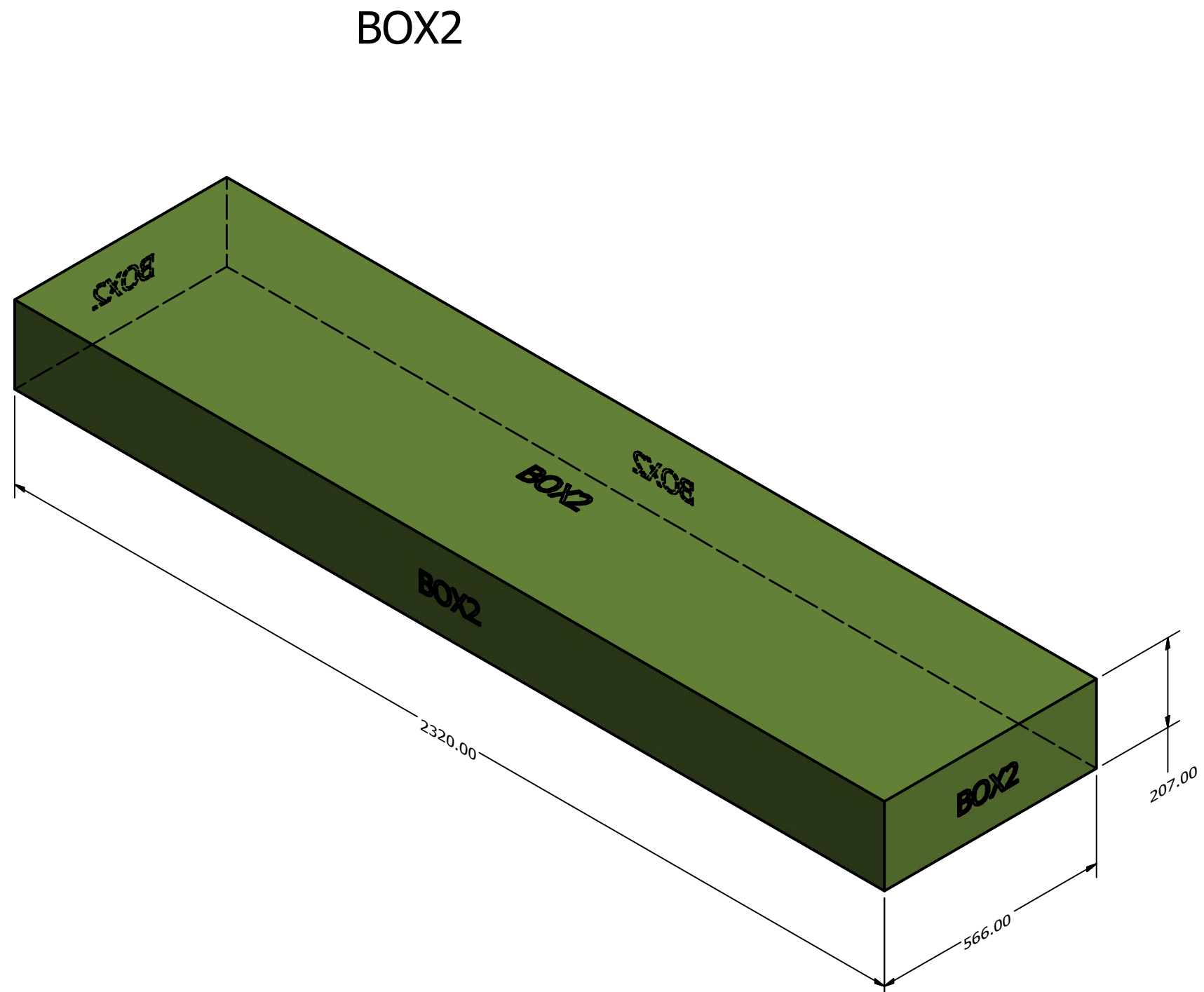

87kg

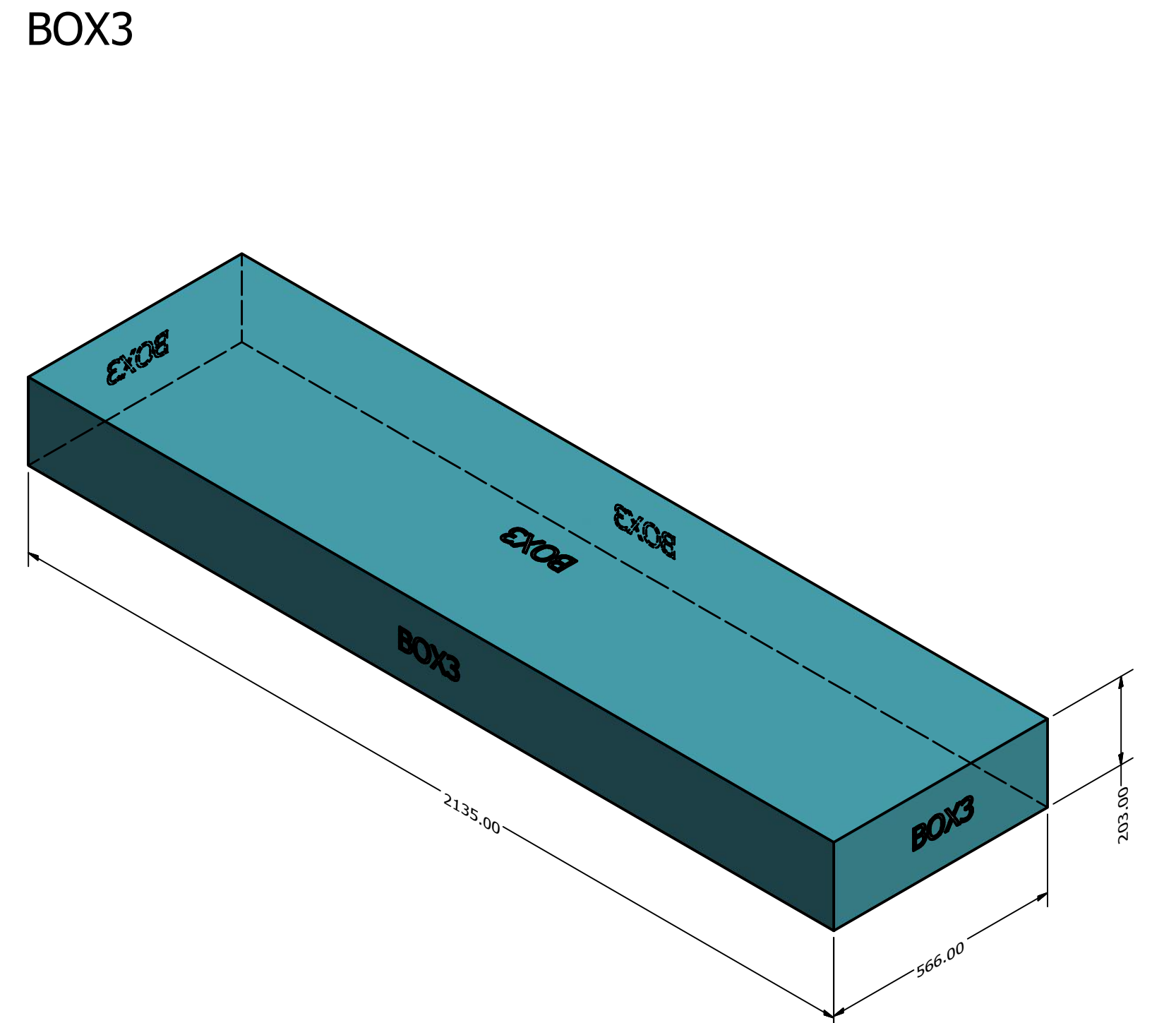

83kg

DRAWN	Rudy	2019-12-16			
CHECKED			TITLE		
QA					
MFG					
APPROVED					
			SIZE	DWG NO	REV
			D	BOXES	
			SCALE	0.10	SHEET 1 OF 1