



TILEPRIME

Specification Features

- TILEABLE SHOWER BASE. INTEGRATED FLANGES AND CURB
- WATERPROOF, LEAK PROOF, SCRATCH AND IMPACT RESISTANT
- PREMIUM QUALITY, NON-BEND TILEABLE SHOWER BASE
- FACTORY-SLOPED BASE TO ENSURE SMOOTH DRAINAGE
- CAN BE TILED USING ANY STANDARD TILE ADHESIVE
- SOLID CORE CONSTRUCTION
- SEAMLESS DESIGN

Technical Information

- Model: TilePrime
- Shower Base Type: Single Threshold
- Drain Location: Left-Hand Drain
- Dimensions: 60" W x 32" D x 6" H
- Product Width: 60"
- Product Depth: 32"

Finish Option:

 Gray

Model SKU#: DTP-1132601

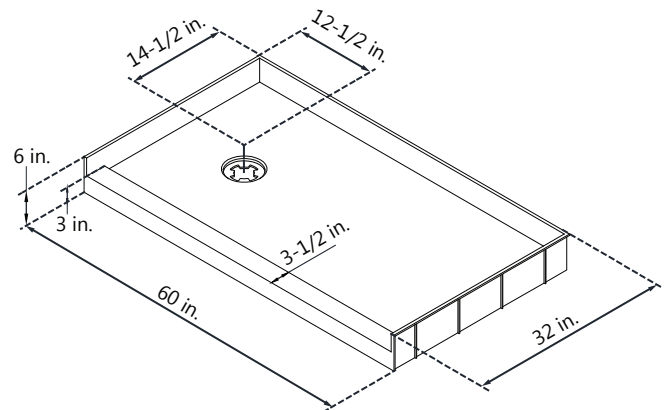

Unique Product Design Details:

Important Notes:



Tile Prime Base Drain

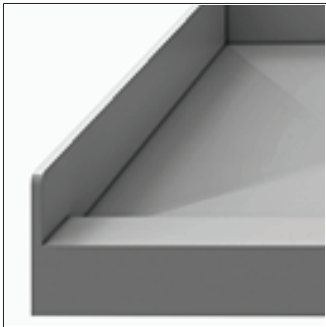

Tile Prime Base Corner

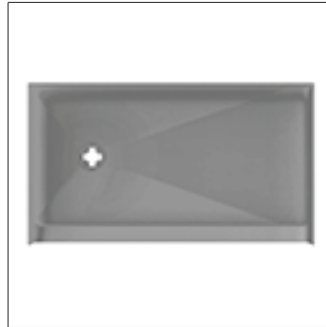

Top View

IMPORTANT! If this unit is going to be installed in a new construction, install all the required plumbing and drainage before installing the shower. Use a competent and licensed (if required by local code) plumber for all plumbing installation.

Make sure that prior to beginning the installation, the surfaces are leveled and solid and will be able to support the total weight of the unit. Also make sure the walls are at right angles. Irregular installation surface level or improper angle of side walls will result in serious problems for your installation.

Protect all primary surfaces of the product during installation. Always use a piece of wood or cardboard to protect the bottom edge and corners of the product prior to installation.

A shower drain is NOT included and must be purchased locally. The TilePrime™ shower base accepts a 3-piece Tile-In shower drain, which can be adjusted for the height of the tile installed on the base. The drain should be installed by a professional to prevent leaks and damage.

Professional installation is required.

Important Disclaimers:

Always store the TilePrime™ shower base flat and away from direct sunlight or any other heat source. Acclimate the base to room temperature 24 hours prior to installation.

Please read Installation Manual thoroughly prior to installing this product.

Please note that you should consult your local building codes with questions on installation compliance standards. Building and plumbing codes may vary by location, and DreamLine® is not responsible for code compliance standards for your project and will not accept any returns.

For commercial customers, we strongly recommend the use of Dreamline's Onsite Contractor Support option.

Dreamline's commercial warranty does not apply to damage or losses resulting from (i) other than normal and proper use and normal service conditions; (ii) improper installation, (iii) installation in or upon an unsuitable surface or areas; (iv) abuse, (v) accident, (vi) alteration, (vii) misuse, (viii) neglect, (ix) unauthorized repair or the failure to utilize suitably qualified and trained persons to perform service and/or repair of the Product, (x) improper maintenance, (xi) failure to follow installation, operating, cleaning or maintenance instructions, and (xii) use of "non-authorized" parts.